

(Super)-Gravities Beyond 4 Dimensions*

Jorge Zanelli

Centro de Estudios Científicos (CECS), Casilla 1469, Valdivia, Chile.

Abstract: These lectures are intended as a broad introduction to Chern Simons gravity and supergravity. The motivation for these theories lies in the desire to have a gauge invariant action –in the sense of fiber bundles– in more than three dimensions, which could provide a firm ground for constructing a quantum theory of the gravitational field. The case of Chern-Simons gravity and its supersymmetric extension for all odd D is presented. No analogous construction is available in even dimensions.

*Lectures given at the 2001 Summer School *Geometric and Topological Methods for Quantum Field Theory*, Villa de Leyva, Colombia, June 2001. E-mail: jz@cecs.cl

Contents

1. Physics and Mathematics.	3
1.1 Renormalizability and the Success of Gauge Theory	4
1.2 The Gravity Puzzle	5
1.3 Minimal Couplings and Connections	6
1.4 Gauge Symmetry and Diffeomorphism Invariance	8
2. General Relativity	9
2.1 Metric and Affine Structures	10
3. First Order Formulation for Gravity	14
3.1 The Vielbein	14
3.2 The Lorentz Connection	15
3.3 Differential forms	16
4. Lanczos-Lovelock Gravity	18
4.1 Dynamical Content	20
4.2 Adding Torsion	22
5. Selecting Sensible Theories	23
5.1 Extending the Lorentz Group	24
5.2 More Dimensions	26
5.3 Chern-Simons	29
5.4 Torsional CS	30
5.5 Even Dimensions	31
6. Supersymmetry	32
6.1 Superalgebra	32
6.2 Supergravity	33
6.3 From Rigid Supersymmetry to Supergravity	34
6.4 Assumptions of Standard Supergravity	34
7. Super AdS algebras	35
7.1 The Fermionic Generators	36
7.2 Closing the Algebra	37
8. CS Supergravity Actions	39
9. Summary	42

10. Hamiltonian Analysis	44
10.1 Degeneracy	45
10.2 Generic counting	46
10.3 Regularity conditions	47
11. Final Comments	47

LECTURE 1

GENERAL RELATIVITY REVISITED

In this lecture, the standard construction of the action principle for general relativity is discussed. The scope of the analysis is to set the basis for a theory of gravity in any number of dimensions, exploiting the similarity between gravity and a gauge theory as a fiber bundle. It is argued that in a theory that describes the spacetime geometry, the metric and affine properties of the geometry should be represented by independent entities, an idea that goes back to the works of Cartan and Palatini. It is shown that the need for an independent description of the affine and metric features of the geometry leads naturally to a formulation of gravity in terms of two independent 1-form fields: the vielbein, e^a , and the spin connection ω_b^a .

Since these lectures are intended for a mixed audience/readership of mathematics and physics students, it would seem appropriate to locate the problems addressed here in the broader map of physics.

1. Physics and Mathematics.

Physics is an experimental science. Current research, however, especially in string theory, could be taken as an indication that the experimental basis of physics is unnecessary. String theory not only makes heavy use of sophisticated modern mathematics, it has also stimulated research in some fields of mathematics. At the same time, the lack of direct experimental evidence, either at present or in the foreseeable future, might prompt the idea that physics could exist without an experimental basis. The identification, of high energy physics as a branch of mathematics, however, is only superficial. High energy physics in general and string theory in particular, have as their ultimate goal the description of nature, while Mathematics is free from this constraint.

There is, however, a mysterious connection between physics and mathematics which runs deep, as was first noticed probably by Pythagoras when he concluded that that, at its deepest level, reality is mathematical in nature. Such is the case with the musical notes produced by a violin string or by the string that presumably describes nature at the Planck scale.

Why is nature at the most fundamental level described by simple, regular, beautiful, mathematical structures? The question is not so much how structures like knot invariants, the index theorem or moduli spaces appear in string theory as gears of the machinery, but why should they occur at all. As E. Wigner put it, *“the miracle of the appropriateness of the language of mathematics for the formulation of the laws of physics is a wonderful gift, which we neither understand nor deserve.”*[1].

Often the connection between theoretical physics and the real world is established through the phenomena described by solutions of differential equations. The aim of the theoretical physicist is to provide economic frameworks to explain why those equations are necessary.

The time-honored approach to obtain dynamical equations is a variational principle: the principle of least action in Lagrangian mechanics, the principle of least time in optics, the principle of highest profit in economics, etc. These principles are postulated with no further justification beyond their success in providing differential equations that reproduce the observed behavior. However, there is also an important aesthetic aspect, that has to do with economy of assumptions, the possibility of a wide range of predictions, simplicity, beauty.

In order to find the correct variational principle, an important criterion is symmetry. Symmetries are manifest in the conservation laws observed in the phenomena. Under some suitable assumptions, symmetries are often strong enough to select the general form of the possible action functionals.

The situation can be summarized more or less in the following scheme:

Feature	Ingredient	Examples
Symmetries	Symmetry group	Translations, Lorentz, gauge
Variational Principle	Action Functional	$\delta I = \delta \int (T - V) dt = 0.$
Dynamics	Field Equations	$\vec{F} = m\vec{a},$ Maxwell eqs.
Phenomena	Solutions	Orbits, states trajectories
Experiments	Data	Positions, times

Theoretical predictions

↓

↑

Theoretical construction

Theoretical research proceeds inductively, upwards from the bottom, guessing the theory from the experimental evidence. Once a theory is built, it predicts new phenomena that should be confronted with experiments, checking the foundations, as well as the consistency of the building above. Axiomatic presentations, on the other hand, go from top to bottom. They are elegant and powerful, but they rarely give a clue about how the theory was constructed and they hide the fact that a theory is usually based on very little experimental evidence, although a robust theory will generate enough predictions and resist many experimental tests.

1.1 Renormalizability and the Success of Gauge Theory

A good example of this way of constructing a physical theory is provided by Quantum Field Theory. Experiments in cloud chambers during the first half of the twentieth century showed collisions and decays of particles whose mass, charge, and a few other attributes could be determined. From this data, a general pattern of possible and forbidden reactions as well as relative probabilities of different processes was painfully constructed. Conservation laws, selection rules, new quantum numbers were suggested and a phenomenological model slowly emerged, which reproduced most of the observations in a satisfactory way. A deeper understanding, however, was lacking. There was no theory from which the laws could be deduced simply and coherently. The next step, then, was to construct such a theory. This was a

major enterprise which finally gave us the Standard Model. The humble word “model”, used instead of “theory”, underlines the fact that important pieces are still missing in it.

The model requires a classical field theory described by a lagrangian capable of reproducing the type of interactions (vertices) and conservation laws observed in the experiments at the lowest order (low energy, weakly interacting regime). Then, the final test of the theory comes from the proof of its internal consistency as a quantum system: **renormalizability**.

It seems that Hans Bethe was the first to observe that non renormalizable theories would have no predictive power and hence renormalizability should be the key test for the physical consistency of a theory [2]. A brilliant example of this principle at work is offered by the theory for electroweak interactions. As Weinberg remarked in his Nobel lecture, if he had not been guided by the principle of renormalizability, his model would have included contributions not only from $SU(2) \times U(1)$ -invariant vector boson interactions –which were believed to be renormalizable, although not proven until a few years later by ’t Hooft [3]– but also from the $SU(2) \times U(1)$ -invariant four fermion couplings, which were known to be non renormalizable [4]. Since a non renormalizable theory has no predictive power, even if it could not be said to be incorrect, it would be scientifically irrelevant like, for instance, a model based on angels and evil forces.

One of the best examples of a successful application of mathematics for the description of nature at a fundamental scale is the principle of **gauge invariance**, that is the invariance of a system under a symmetry group that acts locally. The underlying mathematical structure of the gauge principle is mathematically captured through the concept of **fiber bundle**, as discussed in the review by Sylvie Paycha in this school [5]. For a discussion of the physical applications, see also [6].

Three of the four forces of nature (electromagnetism, weak, and strong interactions) are explained and accurately modelled by a Yang-Mills action built on the assumption that nature should be invariant under a group of transformations acting independently at each point of spacetime. This local symmetry is the key ingredient in the construction of physically testable (renormalizable) theories. Thus, symmetry principles are not only useful in constructing the right (classical) action functionals, but they are often sufficient to ensure the viability of a quantum theory built from a given classical action.

1.2 The Gravity Puzzle

The fourth interaction of nature, the gravitational attraction, has stubbornly resisted quantization. This is particularly irritating as gravity is built on the principle of invariance under general coordinate transformations, which is a local symmetry analogous to the gauge invariance of the other three forces. These lectures will attempt to shed some light on this puzzle.

One could question the logical necessity for the existence of a quantum theory of gravity at all. True fundamental field theories must be renormalizable; effective theories need not be, as they are not necessarily described by quantum mechanics at all. Take for example the

Van der Waals force, which is a residual low energy interaction resulting from the electromagnetic interactions between electrons and nuclei. At a fundamental level it is all quantum electrodynamics, and there is no point in trying to write down a quantum field theory to describe the Van der Waals interaction, which might even be inexistent. Similarly, gravity could be an effective interaction analogous to the Van der Waals force, the low energy limit of some fundamental theory like string theory. There is one difference, however. There is no action principle to describe the Van der Waals interaction and there is no reason to look for a quantum theory for molecular interactions. Thus, a biochemical system is not governed by an action principle and is not expected to be described by a quantum theory, although its basic constituents are described by QED, which is a renormalizable theory.

Gravitation, on the other hand, is described by an action principle. This is an indication that it could be viewed as a fundamental system and not merely an effective force, which in turn would mean that there might exist a quantum version of gravity. Nevertheless, countless attempts by legions of researchers –including some of the best brains in the profession– through the better part of the twentieth century, have failed to produce a sensible (e.g., renormalizable) quantum theory for gravity.

With the development of string theory over the past twenty years, the prevailing view now is that gravity, together with the other three interactions and all elementary particles, are contained as modes of the fundamental string. In this scenario, all four forces of nature including gravity, would be low energy effective phenomena and not fundamental reality. Then, the issue of renormalizability of gravity would not arise, as it doesn't in the case of the Van der Waals force.

Still a puzzle remains here. If the ultimate reality of nature is string theory and the observed high energy physics is just low energy phenomenology described by effective theories, there is no reason to expect that electromagnetic, weak and strong interactions should be governed by renormalizable theories at all. In fact, one would expect that those interactions should lead to non renormalizable theories as well, like gravity or the old four-fermion model for weak interactions. If these are effective theories like thermodynamics or hydrodynamics, one could even wonder why these interactions are described by an action principle at all.

1.3 Minimal Couplings and Connections

Gauge symmetry fixes the form in which matter fields couple to the carriers of gauge interactions. In electrodynamics, for example, the ordinary derivative in the kinetic term for the matter fields, ∂_μ , is replaced by the covariant derivative,

$$\nabla_\mu = \partial_\mu + A_\mu. \tag{1.1}$$

This provides a unique way to couple charged fields, like the electron, and the electromagnetic field. At the same time, this form of interaction avoids dimensionful coupling constants in the action. In the absence of such coupling constants, the perturbative expansion is likely to be well behaved because gauge symmetry imposes severe restrictions on the type of terms that

can be added to the action, as there are very few gauge invariant expressions in a given number of spacetime dimensions. Thus, if the Lagrangian contains all possible terms allowed by the symmetry, perturbative corrections could only lead to rescalings of the coefficients in front of each term in the Lagrangian. These rescalings can always be absorbed in a redefinition of the parameters of the action. This **renormalization** procedure that works in gauge theories is the key to their internal consistency.

The “vector potential” A_μ is a connection 1-form, which means that, under a gauge transformation,

$$\mathbf{A}(\mathbf{x}) \rightarrow \mathbf{A}(\mathbf{x})' = \mathbf{U}(x)\mathbf{A}(\mathbf{x})\mathbf{U}(x)^{-1} + \mathbf{U}(x)d\mathbf{U}^{-1}(x), \quad (1.2)$$

where $U(x)$ represents a position dependent group element. The value of \mathbf{A} depends on the choice of gauge $\mathbf{U}(x)$ and it can even be made to vanish at a given point by an appropriate choice of $U(x)$. The combination ∇_μ is the covariant derivative, a differential operator that, unlike the ordinary derivative and \mathbf{A} itself, transforms homogeneously under the action of the gauge group,

$$\nabla_\mu \rightarrow \nabla'_\mu = \mathbf{U}(x)\nabla_\mu. \quad (1.3)$$

The connection can in general be a matrix-valued object, as in the case of nonabelian gauge theories. In that case, ∇_μ is an operator 1-form,

$$\begin{aligned} \nabla &= d + \mathbf{A} \\ &= dx^\mu(\partial_\mu + \mathbf{A}_\mu). \end{aligned} \quad (1.4)$$

Acting on a function $\phi(x)$, which is in a vector representation of the gauge group ($\phi(x) \rightarrow \phi'(x) = \mathbf{U}(x) \cdot \phi(x)$), the covariant derivative reads

$$\nabla\phi = d\phi + \mathbf{A} \wedge \phi. \quad (1.5)$$

The covariant derivative operator ∇ has a remarkable property: its square is not a differential operator but a multiplicative one, as can be seen from (1.5)

$$\begin{aligned} \nabla\nabla\phi &= d(\mathbf{A}\phi) + \mathbf{A}d\phi + \mathbf{A} \wedge \mathbf{A}\phi \\ &= (d\mathbf{A} + \mathbf{A} \wedge \mathbf{A})\phi \\ &= \mathbf{F}\phi \end{aligned} \quad (1.6)$$

The combination $\mathbf{F} = d\mathbf{A} + \mathbf{A} \wedge \mathbf{A}$ is the field strength of the nonabelian interaction. This generalizes the electric and magnetic fields of electromagnetism and it indicates the presence of energy.

One can see now why the gauge principle is such a powerful idea in physics: the covariant derivative of a field, $\nabla\phi$, defines the coupling between ϕ and the gauge potential \mathbf{A} in a unique way. Furthermore, \mathbf{A} has a uniquely defined field strength \mathbf{F} , which in turn defines the dynamical properties of the gauge field. In 1954, Robert Mills and Chen-Nin Yang grasped

the beauty and the power of this idea and constructed what has been since known as the nonabelian Yang-Mills theory [7].

On the tangent bundle, the covariant derivative corresponding to the gauge group of general coordinate transformations is the usual covariant derivative in differential geometry,

$$\begin{aligned} \mathbf{D} &= d + \mathbf{\Gamma} \\ &= dx^\mu (\partial_\mu + \mathbf{\Gamma}_\mu), \end{aligned} \tag{1.7}$$

where $\mathbf{\Gamma}$ is the Christoffel symbol, involving the metric and its derivatives.

The covariant derivative operator in both cases reflects the fact that these theories are invariant under a group of local transformations, that is, operations which act independently at each point in space. In electrodynamics $\mathbf{U}(x)$ is an element of $U(1)$, and in the case of gravity $\mathbf{U}(x)$ is the Jacobian matrix $(\partial x/\partial x')$, which describes a diffeomorphism, or general coordinate change, $x \rightarrow x'$.

1.4 Gauge Symmetry and Diffeomorphism Invariance

The close analogy between the covariant derivatives ∇ and \mathbf{D} could induce one to believe that the difficulties for constructing a quantum theory for gravity shouldn't be significantly worse than for an ordinary gauge theory like QED. It would seem as if the only obstacles one should expect would be technical, due to the differences in the symmetry group, for instance. There is, however, a more profound difference between gravity and the standard gauge theories that describe Yang-Mills systems. The problem is not that General Relativity lacks the ingredients to make a gauge theory, but that the right action for gravity in four dimensions cannot be written as that of a gauge invariant system for the diffeomorphism group.

In a YM theory, the connection \mathbf{A}_μ is an element of a Lie algebra whose structure is independent of the dynamical equations. In electroweak and strong interactions, the connection is a dynamical field, while both the base manifold and the symmetry group are fixed, regardless of the values of the connection or the position in spacetime. This implies that the Lie algebra has structure constants, which are neither functions of the field A , or the position x . If $G^a(x)$ are the gauge generators in a YM theory, they obey an algebra of the form

$$[G^a(x), G^b(y)] = C_c^{ab} \delta(x, y) G^c(x), \tag{1.8}$$

where C_c^{ab} are the structure constants.

The Christoffel connection $\mathbf{\Gamma}_{\beta\gamma}^\alpha$, instead, represents the effect of parallel transport over the spacetime manifold, whose geometry is determined by the dynamical equations of the theory. The consequence of this is that the diffeomorphisms do not form a Lie algebra but an **open algebra**, which has *structure functions* instead of *structure constants* [8]. This problem can be seen explicitly in the diffeomorphism algebra generated by the hamiltonian constraints of gravity, $\mathcal{H}_\perp(x)$, $\mathcal{H}_i(x)$,

$$\begin{aligned} [\mathcal{H}_\perp(x), \mathcal{H}_\perp(y)] &= g^{ij}(x) \delta(x, y)_{,i} \mathcal{H}_j(y) - g^{ij}(y) \delta(y, x)_{,i} \mathcal{H}_j(x) \\ [\mathcal{H}_i(x), \mathcal{H}_j(y)] &= \delta(x, y)_{,i} \mathcal{H}_j(y) - \delta(x, y)_{,j} \mathcal{H}_i(y) \\ [\mathcal{H}_\perp(x), \mathcal{H}_i(y)] &= \delta(x, y)_{,i} \mathcal{H}_\perp(y) \end{aligned} \tag{1.9}$$

where $\delta(y, x)_{,i} = \frac{\partial\delta(y,x)}{\partial x^i}$.

Here one now finds functions of the dynamical fields, $g^{ij}(x)$ playing the role of the structure constants C_c^{ab} , which identify the symmetry group in a gauge theory. If the structure “constants” were to change from one point to another, it would mean that the symmetry group is not uniformly defined throughout spacetime, which would prevent an interpretation of gravity in terms of fiber bundles, where the base is spacetime and the symmetry group is the fiber.

It is sometimes asserted in the literature that gravity is a gauge theory for the translation group, much like the Yang Mills theory of strong interactions is a gauge theory for the $SU(3)$ group. We see that although this is superficially correct, the usefulness of this statement is limited by the profound differences a gauge theory with fiber bundle structure and another with an open algebra such as gravity.

2. General Relativity

The question we would like to address is: *What would you say is the right action for the gravitational field in a spacetime of a given dimension?* On November 25 1915, Albert Einstein presented to the Prussian Academy of Natural Sciences the equations for the gravitational field in the form we now know as Einstein equations [9]. Curiously, five days before, David Hilbert had proposed the correct action principle for gravity, based on a communication in which Einstein had outlined the general idea of what should be the form of the equations [10]. This is not so surprising in retrospect, because as we shall see, there is a unique action in four dimensions which is compatible with general relativity that has flat space as a solution. If one allows nonflat geometries, there is essentially a one-parameter family of actions that can be constructed: the Einstein-Hilbert form plus a cosmological term,

$$I[g] = \int \sqrt{-g}(\alpha_1 R + \alpha_2) d^4x, \tag{2.1}$$

where R is the scalar curvature, which is a function of the metric $g_{\mu\nu}$, its inverse $g^{\mu\nu}$, and its derivatives (for the definitions and conventions we use here, see Ref.[11]). The expression $I[g]$ is the only functional of the metric which is invariant under general coordinate transformations and gives second order field equations in four dimensions. The coefficients α_1 and α_2 are related to the gravitational constant and the cosmological constant through

$$\alpha_1 = \frac{1}{16\pi G}, \quad \alpha_2 = \frac{\Lambda}{8\pi G}. \tag{2.2}$$

Einstein equations are obtained by extremizing this action (2.1) and they are unique in that:

- (i) They are tensorial equations
- (ii) They involve only up to second derivatives of the metric
- (iii) They reproduce Newtonian gravity in the weak field nonrelativistic approximation.

The first condition implies that the equations have the same meaning in all coordinate systems. This follows from the need to have a coordinate independent (covariant) formulation of gravity in which the gravitational force is replaced by the nonflat geometry of spacetime. The gravitational field being a geometrical entity implies that it cannot resort to a preferred coordinate choice or, in physical terms, a preferred set of observers.

The second condition means that Cauchy conditions are necessary (and sufficient in most cases) to integrate the equations. This condition is a concession to the classical physics tradition: the possibility of determining the gravitational field at any moment from the knowledge of the positions and momenta at a given time. This requirement is also the hallmark of Hamiltonian dynamics, which is the starting point for canonical quantum mechanics.

The third requirement is the correspondence principle, which accounts for our daily experience that an apple and the moon fall the way they do.

If one further assumes that Minkowski space be among the solutions of the matter-free theory, then one must set $\Lambda = 0$, as most sensible particle physicists would do. If, on the other hand, one believes in static homogeneous and isotropic cosmologies, then Λ must have a finely tuned nonzero value. Experimentally, Λ has a value of the order of 10^{-120} in some “natural” units [12]. Furthermore, astrophysical measurements seem to indicate that Λ must be positive [13]. This presents a problem because there seems to be no theoretical way to predict this “unnaturally small” nonzero value.

As we will see in the next lecture, for other dimensions, the Einstein-Hilbert action is not the only possibility in order to satisfy conditions (i-iii).

2.1 Metric and Affine Structures

We conclude this introduction by discussing what we mean by spacetime geometry. Geometry is sometimes understood as the set of assertions one can make about the points in a manifold and their relations. This broad (and vague) idea, is often interpreted as encoded in the metric tensor, $g_{\mu\nu}(x)$, which provides the notion of distance between nearby points with slightly different coordinates,

$$ds^2 = g_{\mu\nu} dx^\mu dx^\nu. \quad (2.3)$$

This is the case in Riemannian geometry, where all objects that are relevant for the spacetime can be constructed from the metric. However, one can distinguish between **metric** and **affine** features of space, that is, between the notions of **distance** and **parallelism**. Metricity refers to lengths, areas, volumes, etc., while affinity refers to scale invariant properties such as shapes.

Euclidean geometry was constructed using two elementary instruments: the compass and the (unmarked) straightedge. The first is a metric instrument because it allows comparing lengths and, in particular, drawing circles. The second is used to draw straight lines which, as will be seen below, is a basic affine operation. In order to fix ideas, let’s consider a few examples from Euclidean geometry. Pythagoras’ famous theorem is a metric statement; it relates the lengths of the sides of a triangle:

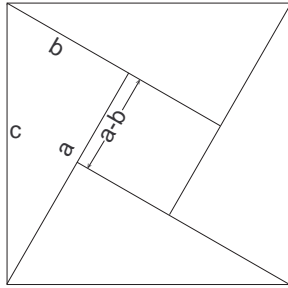

Figure 1: Pythagoras theorem: $c^2 = (a - b)^2 + 4[ab]/2$

Affine properties on the other hand, do not change if the length scale is changed, such as the shape of a triangle or, more generally, the angle between two straight lines. A typical affine statement is, for instance, the fact that when two parallel lines intersect a third, the corresponding angles are equal, as seen in **Fig.2**.

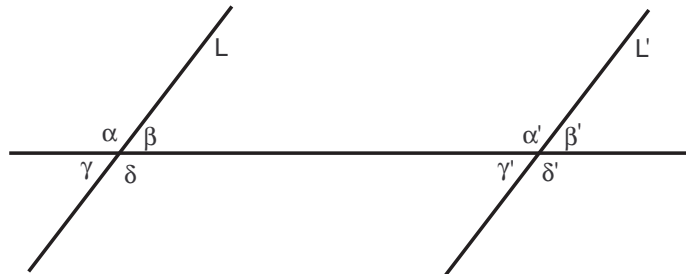

Figure 2: Affine property: $L \parallel L' \Leftrightarrow \alpha = \alpha' = \delta = \delta', \beta = \beta' = \gamma = \gamma'$

Of course parallelism can be reduced to metricity. As we learned in school, one can draw a parallel to a line **L** using a right angled triangle (**W**) and an unmarked straightedge (**R**): One aligns one of the short sides of the triangle with the straight line and rests the other short side on the ruler. Then, one slides the triangle to where the parallel is to be drawn, as in **Fig.3**.

Thus, given a way to draw right angles and a straight line in space, one can define parallel transport. As any child knows from the experience of stretching a string or a piece of rubber band, a straight line is the shape of the shortest line between two points. This is clearly a metric feature because it requires *measuring* lengths. Orthogonality is also a metric notion that can be defined using the scalar product obtained from the metric. A right angle is a metric feature because we should be able to *measure* angles, or measure the sides of triangles¹. We will now show that, strictly speaking, *parallelism does not require metricity*.

¹The Egyptians knew how to *use* Pythagoras' theorem to make a right angle, although they didn't know how to prove it. Their recipe was probably known long before, and all good construction workers today still

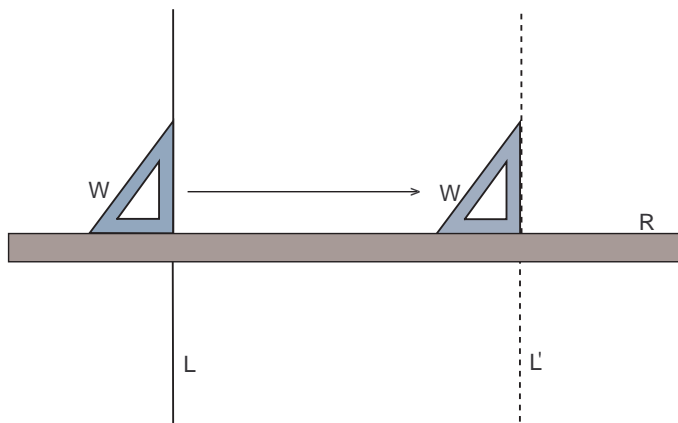

Figure 3: Constructing parallels using a right-angled triangle (W) and a straightedge (R)

There is something excessive about the construction in **Fig.3** because one doesn't *have* to use a right angle. In fact, any angle could be used in order to draw a parallel to **L** in the last example, so long as it *doesn't change* when we slide it from one point to another, as shown in **Fig.4**.

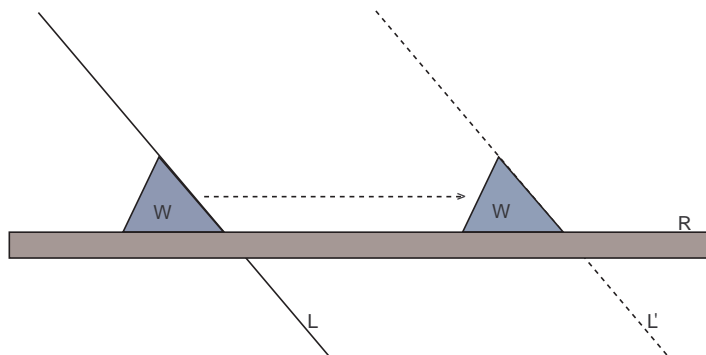

Figure 4: Constructing parallels using an arbitrary angle-preserving wedge (W) and a straightedge (R) .

We see that the essence of parallel transport is a rigid, angle-preserving wedge and a straightedge to connect two points. There is still some cheating in this argument because we took the construction of a straightedge for granted. What if we had no notion of distance, how do we know what a straight line is?

know the recipe: make a loop of rope with 12 segments of equal length. Then, the triangle formed with the loop so that its sides are 3, 4 and 5 segments long is such that the shorter segments are perpendicular to each other [14].

There is a way to construct a straight line that doesn't require a notion of distance between two points in space. Take two short enough segments (two short sticks, matches or pencils would do), and slide them one along the other, as a cross country skier would do. In this way a straight line is generated by *parallel transport of a vector along itself*, and we have not used distance anywhere. It is this *affine* definition of a straight line that can be found in Book I of Euclid's Elements. This definition could be regarded as the *straightest line*, which does not necessarily coincide with the *line of shortest distance*. They are conceptually independent.

In a space devoid of a metric structure the straightest line could be a rather strange looking curve, but it could still be used to define parallelism. Suppose the ruler **R** has been constructed by transporting a vector along itself, then one can use it to define parallel transport as in **Fig.5**.

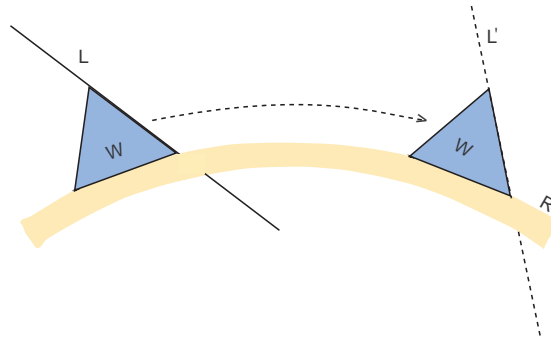

Figure 5: Constructing parallels using any angle-preserving wedge (W) and an arbitrary ruler (R). Any ruler is as good as another.

There is nothing wrong with this construction apart from the fact that it need not coincide with the more standard metric construction in **Fig.3**. The fact that this purely affine construction is logically acceptable means that parallel transport needs not be a metric concept unless one insists on reducing affinity to metricity.

In differential geometry, parallelism is encoded in the affine connection mentioned earlier, $\Gamma_{\beta\gamma}^{\alpha}(x)$, so that a vector u at the point of coordinates x is said to be parallel to the vector \tilde{u} at a point with coordinates $x + dx$, if their components are related by “parallel transport”,

$$\tilde{u}^{\alpha}(x + dx) = \Gamma_{\beta\gamma}^{\alpha} dx^{\beta} u^{\gamma}(x). \quad (2.4)$$

The affine connection $\Gamma_{\beta\gamma}^{\alpha}(x)$ need not be logically related to the metric tensor $g_{\mu\nu}(x)$.

Einstein's formulation of General Relativity adopted the point of view that the spacetime metric is the only dynamically independent field, while the affine connection is a function of

the metric given by the Christoffel symbol,

$$\Gamma_{\beta\gamma}^{\alpha} = \frac{1}{2}g^{\alpha\lambda}(\partial_{\beta}g_{\lambda\gamma} + \partial_{\gamma}g_{\lambda\beta} + \partial_{\lambda}g_{\beta\gamma}). \quad (2.5)$$

This is the starting point for a controversy between Einstein and Cartan, which is vividly recorded in the correspondence they exchanged between May 1929 and May 1932 [15]. In his letters, Cartan insisted politely but forcefully that metricity and parallelism could be considered as independent, while Einstein pragmatically replied that since the space we live in seems to have a metric, it would be more economical to assume the affine connection to be a function of the metric. Einstein argued in favor of economy of independent fields. Cartan advocated economy of assumptions.

Here we adopt Cartan’s point of view. It is less economical in dynamical variables but is more economical in assumptions and therefore more general. This alone would not be sufficient argument to adopt Cartan’s philosophy, but it turns out to be more transparent in many ways and to lend itself better to make a gauge theory of gravity.

3. First Order Formulation for Gravity

We view spacetime as a smooth D -dimensional manifold of lorentzian signature M , which at every point x possesses a D -dimensional tangent space T_x . The idea is that this tangent space T_x is a good linear approximation of the manifold M in the neighborhood of x . This means that there is a way to represent tensors over M by tensors on the tangent space².

3.1 The Vielbein

The precise translation (isomorphism) between the tensor spaces on M and on T_x is made by means of a dictionary, also called “*soldering form*” or simply, “*vielbein*”. The coordinate separation dx^{μ} , between two infinitesimally close points on M is mapped to the corresponding separation dz^a in T_x , as

$$dz^a = e_{\mu}^a(x)dx^{\mu} \quad (3.1)$$

The family $\{e_{\mu}^a(x), a = 1, \dots, D = \dim M\}$ can also be seen as a local orthonormal frame on M . The definition (3.1) makes sense only if the vielbein $e_{\mu}^a(x)$ transforms as a covariant vector under diffeomorphisms on M and as a contravariant vector under local Lorentz rotations of T_x , $SO(1, D - 1)$ (we assumed the signature of the manifold M to be Lorentzian). A similar one to one correspondence can be established between tensors on M and on T_x : if Π is a tensor with components $\Pi^{\mu_1 \dots \mu_n}$ on M , then the corresponding tensor on the tangent space T_x is³

$$P^{a_1 \dots a_n}(x) = e_{\mu_1}^{a_1}(x) \dots e_{\mu_n}^{a_n}(x) \Pi^{\mu_1 \dots \mu_n}(x). \quad (3.2)$$

²Here, only the essential ingredients are given. For a more extended discussion, there are several texts such as those of Refs.[6], [16] and [17].

³The inverse vielbein $e_a^{\mu}(x)$ where $e_a^{\nu}(x)e_{\nu}^b(x) = \delta_a^b$, and $e_{\nu}^a(x)e_a^{\mu}(x) = \delta_{\nu}^{\mu}$, relates lower index tensors,

$$P_{a_1 \dots a_n}(x) = e_{a_1}^{\mu_1}(x) \dots e_{a_n}^{\mu_n}(x) \Pi_{\mu_1 \dots \mu_n}(x).$$

An example of this map between tensors on M and on T_x is the relation between the metrics of both spaces,

$$g_{\mu\nu}(x) = e_\mu^a(x)e_\nu^b(x)\eta_{ab}. \quad (3.3)$$

This relation can be read as to mean that the vielbein is in this sense the square root of the metric. Given $e_\mu^a(x)$ one can find the metric and therefore, all the metric properties of spacetime are contained in the vielbein. The converse, however, is not true: given the metric, there exist infinitely many choices of vielbein that reproduce the same metric. If the vielbein are transformed as

$$e_\mu^a(x) \longrightarrow e'^a_\mu(x) = \Lambda_b^a(x)e_\mu^b(x), \quad (3.4)$$

where the matrix $\Lambda(x)$ leaves the metric in the tangent space unchanged,

$$\Lambda_c^a(x)\Lambda_d^b(x)\eta_{ab} = \eta_{cd}, \quad (3.5)$$

then the metric $g_{\mu\nu}(x)$ is clearly unchanged. The matrices that satisfy (3.5) form the Lorentz group $SO(1, D-1)$. This means, in particular, that there are many more components in e_μ^a than in $g_{\mu\nu}$. In fact, the vielbein has D^2 independent components, whereas the metric has only $D(D+1)/2$. The mismatch is exactly $D(D-1)/2$, the number of independent rotations in D dimensions.

3.2 The Lorentz Connection

The Lorentz group acts on tensors at each T_x independently, that is, the matrices Λ that describe the Lorentz transformations are functions of x . In order to define a derivative of tensors in T_x , one must compensate for the fact that at neighboring points the Lorentz rotations are not the same. This is not different from what happens in any other gauge theory: one needs to introduce a connection for the Lorentz group, $\omega_{b\mu}^a(x)$, such that, if $\phi^a(x)$ is a field that transforms as a vector under the Lorentz group, its covariant derivative,

$$D_\mu\phi^a(x) = \partial_\mu\phi^a(x) + \omega_{b\mu}^a(x)\phi^b(x), \quad (3.6)$$

also transforms like a vector under $SO(1, D-1)$ at x . This requirement means that under a Lorentz rotation $\Lambda_c^a(x)$, $\omega_{b\mu}^a(x)$ changes as a connection [see (1.2)]

$$\omega_{b\mu}^a(x) \longrightarrow \omega'^a_{b\mu}(x) = \Lambda_c^a(x)\Lambda_b^d(x)\omega_{d\mu}^c(x) + \Lambda_c^a(x)\partial_\mu\Lambda_b^c(x). \quad (3.7)$$

In physics, $\omega_{b\mu}^a(x)$ is often called the *spin connection*, but Lorentz connection would be a more appropriate name. The word “spin” is due to the fact that $\omega_{b\mu}^a$ arises naturally in the discussion of spinors, which carry a special representation of the group of rotations in the tangent space.

The spin connection can be used to define *parallel transport* of Lorentz tensors in the tangent space T_x as one goes from the point x to a nearby point $x+dx$. The parallel transport of the vector field $\phi^a(x)$ from the point x to $x+dx$, is a vector at $x+dx$, $\phi^a_{||}(x+dx)$, defined as

$$\phi^a_{||}(x+dx) \equiv \phi^a(x) + dx^\mu\partial_\mu\phi^a(x) + dx^\mu\omega_{b\mu}^a(x)\phi^b(x). \quad (3.8)$$

Here one sees that the covariant derivative measures the change in a tensor produced by parallel transport between neighboring points,

$$dx^\mu D_\mu \phi^a(x) = \phi^a_{||}(x + dx) - \phi^a(x). \quad (3.9)$$

In this way, the affine properties of space are encoded in the components $\omega^a_{b\mu}(x)$, which are, until further notice, totally arbitrary and independent from the metric.

The number of independent components of $\omega^a_{b\mu}$ is determined by the symmetry properties of $\omega^{ab}_\mu = \eta^{bc} \omega^a_{c\mu}$ under permutations of a and b . It is easy to see that demanding that the metric η^{ab} remain invariant under parallel transport implies that the connection should be antisymmetric, $\omega^{ab}_\mu = -\omega^{ba}_\mu$. We leave the proof as an exercise to the reader. Then, the number of independent components of ω^{ab}_μ is $D^2(D-1)/2$. This is *less* than the number of independent components of the Christoffel symbol, $D^2(D+1)/2$.

3.3 Differential forms

It can be observed that both the vielbein and the spin connection appear through the combinations

$$e^a(x) \equiv e^a_\mu(x) dx^\mu, \quad (3.10)$$

$$\omega^a_b(x) \equiv \omega^a_{b\mu}(x) dx^\mu, \quad (3.11)$$

that is, they are local 1-forms. This is not an accident. It turns out that all the geometric properties of M can be expressed with these two 1-forms and their exterior derivatives only. Since both e^a and ω^a_b only carry Lorentz indices, these 1-forms are scalars under diffeomorphisms on M , indeed, they are coordinate-free, as all exterior forms. This, means that in this formalism the spacetime tensors are replaced by tangent space tensors. In particular, the Riemann curvature 2-form is⁴

$$\begin{aligned} R^a_b &= d\omega^a_b + \omega^a_b \wedge \omega^a_b \\ &= \frac{1}{2} R^a_{b\mu\nu} dx^\mu \wedge dx^\nu, \end{aligned} \quad (3.12)$$

where $R^a_{b\mu\nu} \equiv e^a_\alpha e^\beta_b R^\alpha_{\beta\mu\nu}$ are the components of the usual Riemann tensor projected on the tangent space (see [11]).

The fact that $\omega^a_b(x)$ is a 1-form, just like the gauge potential in Yang-Mills theory, $A^a_b = A^a_{b\mu} dx^\mu$, suggests that they are similar, and in fact they both are connections of a gauge group⁵. Their transformation laws have the same form and the curvature R^a_b is completely analogous to the field strength in Yang-Mills,

$$F^a_b = dA^a_b + A^a_c \wedge A^c_b. \quad (3.13)$$

⁴Here d stands for the 1-form exterior derivative operator $dx^\mu \partial_\mu \wedge$.

⁵In what for physicists is fancy language, ω is a locally defined Lie algebra valued 1-form on M , which is also a connection on the principal $SO(D-1, 1)$ -bundle over M .

There is an asymmetry with respect to the vielbein, though. Its transformation law under the Lorentz group is not that of a connection but of a vector. There is another important geometric object obtained from derivatives of e^a which is analogous to the Riemann tensor is another, the Torsion 2-form,

$$T^a = de^a + \omega_b^a \wedge e^b, \quad (3.14)$$

which, unlike R_b^a is a covariant derivative of a vector, and is not a function of the vielbein only.

Thus, the basic building blocks of first order gravity are e^a , ω_b^a , R_b^a , T^a . With them one must put together an action. But, are there other building blocks? The answer is no and the proof is by exhaustion. As a cowboy would put it, if there were any more of them 'round here, we would have heard... And we haven't.

There is a more subtle argument to rule out the existence of other building blocks. We are interested in objects that transform in a controlled way under Lorentz rotations (vectors, tensors, spinors, etc.). Taking the covariant derivatives of e^a , R_b^a , and T^a , one finds always combinations of the same objects, or zero:

$$De^a = de^a + \omega_b^a \wedge e^b = T^a \quad (3.15)$$

$$DR_b^a = dR_b^a + \omega_c^a \wedge R_b^c + \omega_b^c \wedge R_c^a = 0 \quad (3.16)$$

$$DT^a = dT^a + \omega_b^a \wedge T^b = R_b^a \wedge e^b. \quad (3.17)$$

The first relation is just the definition of torsion and the other two are the Bianchi identities, which are directly related to the fact that the exterior derivative is nilpotent, $d^2 = \partial_\mu \partial_\nu dx^\mu \wedge dx^\nu = 0$. We leave it to the reader to prove these identities.

In the next lecture we discuss the construction of the possible actions for gravity using these ingredients. In particular, in 4 dimensions, the Einstein action can be written as

$$I[g] = \int \epsilon_{abcd} (\alpha R^{ab} e^c e^d + \beta e^a e^b e^c e^d). \quad (3.18)$$

This is basically the only action for gravity in dimension four, but many more options exist in higher dimensions.

LECTURE 2

GRAVITY AS A GAUGE THEORY

As we have seen, symmetry principles help in constructing the right classical action. More importantly, they are often sufficient to ensure the viability of a quantum theory obtained from the classical action. In particular, local or gauge symmetry is the key to prove consistency (renormalizability) of the field theories we know for the correct description of three of the four basic interactions of nature. The gravitational interaction has stubbornly escaped this rule in spite of the fact that, as we saw, it is described by a theory based on general covariance,

which is a local invariance quite analogous to gauge symmetry. In this lecture we try to shed some light on this puzzle.

In 1955, less than a year after Yang and Mills proposed their model for nonabelian gauge invariant interactions, Ryoyu Utiyama showed that the Einstein theory can be written as a gauge theory for the Lorentz group [18]. This can be checked directly from the expression (3.18), which is a Lorentz scalar and hence, trivially invariant under (local) Lorentz transformations.

Our experience is that the manifold where we live is approximately flat, four dimensional Minkowski spacetime. This space is certainly invariant under the Lorentz group $SO(3,1)$, but it also allows for translations. This means that it would be nice to view $SO(3,1)$ as a subgroup of a larger group which contains symmetries analogous to translations,

$$SO(3,1) \hookrightarrow G. \quad (3.19)$$

The smallest nontrivial choices for G –which are not just $SO(3,1) \times G_{0-}$, are:

$$G = \begin{cases} SO(4,1) & \text{de Sitter} \\ SO(3,2) & \text{anti-de Sitter} \\ ISO(3,1) & \text{Poincaré} \end{cases} \quad (3.20)$$

The de Sitter and anti-de Sitter groups are semisimple, while the Poincaré group, which is a contraction of the other two, is not semisimple. (This is a rather technical detail but it means that, unlike the Poincaré group, both $SO(4,1)$ and $SO(3,2)$ are free of invariant abelian subgroups. Semisimple groups are preferred as gauge groups because they have an invertible metric in the group manifold.)

Since a general coordinate transformation

$$x^i \rightarrow x^i + \xi^i, \quad (3.21)$$

looks like a local translation, it is natural to expect that diffeomorphism invariance could be identified with the local boosts or translations necessary to enlarge the Lorentz group into one of those close relatives in (3.20). Several attempts to carry out this identification, however, have failed. The problem is that there seems to be no action for general relativity, invariant under one of these extended groups [19, 20, 21, 22]. In other words, although the fields ω^{ab} and e^a match the generators of the group G , there is no G -invariant 4-form available constructed with the building blocks listed above.

As we shall see next, in odd dimensions ($D = 2n - 1$), and only in that case, gravity can be cast as a gauge theory of the groups $SO(D,1)$, $SO(D-1,2)$, or $ISO(D-1,1)$, in contrast with what one finds in dimension four.

4. Lanczos-Lovelock Gravity

We turn now to the construction of an action for gravity using the building blocks at our disposal: e^a , ω_b^a , R_b^a , T^a . It is also allowed to include the only two invariant tensors of

the Lorentz group, η_{ab} , and $\epsilon_{a_1 \dots a_D}$ to raise, lower and contract indices. The action must be an integral over the D -dimensional spacetime manifold, which means that the lagrangian must be a D -form. Since exterior forms are scalars under general coordinate transformations, general covariance is guaranteed by construction and we need not worry about it. The action principle cannot depend on the choice of basis in the tangent space since Lorentz invariance should be respected. A sufficient condition to ensure Lorentz invariance is to demand the lagrangian to be a Lorentz scalar, although, as we will see, this is not strictly necessary.

Thus, we tentatively postulate the lagrangian for gravity to be a D -form constructed by taking linear combinations of products of the above ingredients in any possible way so as to form a Lorentz scalar. We exclude from the ingredients functions such as the metric and its inverse, which rules out the Hodge \star -dual. The only justification for this is that: **i**) it reproduces the known cases, and **ii**) it explicitly excludes inverse fields, like $e_a^\mu(x)$, which would be like A_μ^{-1} in Yang-Mills theory (see [23] and [24] for more on this). This postulate rules out the possibility of including tensors like the Ricci tensor $R_{\mu\nu} = \eta_{ac} e_\mu^c e_b^\lambda R_{\lambda\nu}^{ab}$, or $R_{\alpha\beta} R_{\mu\nu} R^{\alpha\mu\beta\nu}$, etc. That this is sufficient and necessary to account for all sensible theories of gravity in D dimensions is the contents of a theorem due to David Lovelock [25], which in modern language can be stated thus:

Theorem [Lovelock,1970-Zumino,1986]: The most general action for gravity that does not involve torsion, which gives at most second order field equations for the metric and is of the form

$$I_D = \kappa \int \sum_{p=0}^{[D/2]} \alpha_p L^{(D,p)}, \quad (4.1)$$

where the α_p s are arbitrary constants, and $L^{(D,p)}$ is given by

$$L^{(D,p)} = \epsilon_{a_1 \dots a_D} R^{a_1 a_2} \dots R^{a_{2p-1} a_{2p}} e^{a_{2p+1}} \dots e^{a_D}. \quad (4.2)$$

Here and in what follows we omit the wedge symbol in the exterior products. For $D = 2$ this action reduces to a linear combination of the 2-dimensional Euler character, χ_2 , and the spacetime volume (area),

$$\begin{aligned} I_2 &= \kappa \int \alpha_0 L^{(2,0)} + \alpha_1 L^{(2,1)} \\ &= \kappa \int \sqrt{|g|} \left(\frac{\alpha_0}{2} R + 2\alpha_1 \right) d^2x \\ &= \alpha'_0 \cdot \chi_2 + \alpha'_1 \cdot V_2. \end{aligned} \quad (4.3)$$

This action has only one local extremum, $V = 0$, which reflects the fact that, unless other matter sources are included, I_2 does not make a very interesting dynamical theory for the geometry. If the geometry is restricted to have a prescribed boundary this action describes the shape of a soap bubble, the famous Plateau problem: *What is the surface of minimal area that has a certain fixed closed curve as boundary?*

For $D = 3$, (4.1) reduces to the Hilbert action with cosmological constant, and for $D = 4$ the action picks up in addition the four dimensional Euler invariant χ_4 . For higher dimensions the lagrangian is a polynomial in the curvature 2-form of degree $d \leq D/2$. In even dimensions the highest power in the curvature is the Euler character χ_D . Each term $L^{(D,p)}$ is the continuation to D dimensions of the Euler density from dimension $p < D$ [23].

One can be easily convinced, assuming the torsion tensor vanishes identically, that the action (4.1) is the most general scalar D -form that be constructed using the building blocks we considered. The first nontrivial generalization of Einstein gravity occurs in five dimensions, where a quadratic term can be added to the lagrangian. In this case, the 5-form

$$\epsilon_{abcde} R^{ab} R^{cd} e^e = \sqrt{|g|} \left[R^{\alpha\beta\gamma\delta} R_{\alpha\beta\gamma\delta} - 4R^{\alpha\beta} R_{\alpha\beta} + R^2 \right] d^5x \quad (4.4)$$

can be identified as the Gauss-Bonnet density, whose integral in four dimensions gives the Euler character χ_4 . In 1938, Cornelius Lanczos noticed that this term could be added to the Einstein-Hilbert action in five dimensions [26]. It is intriguing that he did not go beyond $D = 5$. The generalization to arbitrary D was obtained by Lovelock more than 30 years later as the Lanczos -Lovelock (**LL**) lagrangians,

$$L_D = \sum_{p=0}^{[D/2]} \alpha_p L^{(D,p)}. \quad (4.5)$$

These lagrangians were also identified as describing the only ghost-free effective theories for spin two fields⁶, generated from string theory at low energy [27, 23]. From our perspective, the absence of ghosts is only a reflection of the fact that the LL action yields at most second order field equations for the metric, so that the propagators behave as αk^{-2} , and not as $\alpha k^{-2} + \beta k^{-4}$, as would be the case in a higher derivative theory.

4.1 Dynamical Content

Extremizing the LL action (4.1) with respect to e^a and ω^{ab} , yields

$$\delta I_D = \int [\delta e^a \mathcal{E}_a + \delta \omega^{ab} \mathcal{E}_{ab}] = 0, \quad (4.6)$$

modulo surface terms. The condition for I_D to have an extreme under arbitrary first order variations is that the coefficients \mathcal{E}_a \mathcal{E}_{ab} vanish identically. This condition is the geometry satisfies the field equations

$$\mathcal{E}_a = \sum_{p=0}^{[\frac{D-1}{2}]} \alpha_p (d - 2p) \mathcal{E}_a^{(p)} = 0, \quad (4.7)$$

⁶Physical states in quantum field theory have positive probability, which means that they are described by positive norm vectors in a Hilbert space. Ghosts instead, are unphysical states of negative norm. A lagrangian containing arbitrarily high derivatives of fields generally leads to ghosts. Thus, the fact that a gravitational lagrangian such as 4.5 leads to a ghost-free theory is highly nontrivial.

and

$$\mathcal{E}_{ab} = \sum_{p=1}^{\lfloor \frac{D-1}{2} \rfloor} \alpha_p p(d-2p) \mathcal{E}_{ab}^{(p)} = 0, \quad (4.8)$$

where we have defined

$$\mathcal{E}_a^{(p)} := \epsilon_{ab_2 \dots b_{D-1}} R^{b_2 b_3} \dots R^{b_{2p} b_{2p+1}} e^{b_{2p+1}} \dots e^{b_D}, \quad (4.9)$$

$$\mathcal{E}_{ab}^{(p)} := \epsilon_{aba_3 \dots a_d} R^{a_3 a_4} \dots R^{a_{2p-1} a_{2p}} T^{a_{2p+1}} e^{a_{2p+2}} \dots e^{a_D}. \quad (4.10)$$

These equations involve only first derivatives of e^a and ω_b^a , simply because $d^2 = 0$. If one furthermore assumes, as is usually done, that the torsion vanishes,

$$T^a = de^a + \omega_b^a e^b = 0, \quad (4.11)$$

Eq. (4.10) is automatically satisfied and can be solved for ω as a function of derivative of e and its inverse $\omega = \omega(e, \partial e)$. Substituting the spin connection back into (4.9) yields second order field equations for the metric. These equations are identical to the ones obtained from varying the LL action written in terms of the Riemann tensor and the metric,

$$I_D[g] = \int d^D x \sqrt{g} \left[\alpha'_0 + \alpha'_1 R + \alpha'_2 (R^{\alpha\beta\gamma\delta} R_{\alpha\beta\gamma\delta} - 4R^{\alpha\beta} R_{\alpha\beta} + R^2) + \dots \right]. \quad (4.12)$$

This purely metric form of the action is the so-called second order formalism. It might seem surprising that the action (4.12) yields only second order field equations for the metric, since the lagrangian contains second derivatives of $g_{\mu\nu}$. In fact, it is sometimes asserted that the presence of terms quadratic in curvature necessarily bring in higher order equations for the metric but, as we have seen, this is not true for the LL action. Higher derivatives of the metric would mean that the initial conditions required to uniquely determine the time evolution are not those of General Relativity and hence the theory would have different degrees of freedom from standard gravity. It also means that the propagators in the quantum theory develops poles at imaginary energies: ghosts. Ghost states spoil the unitarity of the theory, making it hard to interpret its predictions.

One important feature that makes the LL theories very different for $D > 4$ from those for $D \leq 4$ is the fact that in the first case the equations are nonlinear in the curvature tensor, while in the latter case all equations are linear in R^{ab} and in T^a . In particular, while for $D \leq 4$ the equations (4.10) imply the vanishing of torsion, this is no longer true for $D > 4$. In fact, the field equations evaluated in some configurations may leave some components of the curvature and torsion tensors indeterminate. For example, Eq.(4.8) has the form of a polynomial in R^{ab} times T^a , and it is possible that the polynomial vanishes identically, leaving the torsion tensor completely arbitrary. However, the configurations for which the equations do not determine R^{ab} and T^a completely form sets of measure zero in the space of geometries. In a generic case, outside of these degenerate configurations, the LL theory has the same $D(D-3)/2$ degrees of freedom as in ordinary gravity [28].

4.2 Adding Torsion

Lovelock's theorem assumes torsion to be identically zero. If equation (4.11) is assumed as an identity, means that e^a and ω_b^a are no longer independent fields, contradicting the assumption that these fields correspond to two equally independent features of the geometry. Moreover, for $D \leq 4$, equation (4.11) coincides with (4.10), so that imposing the torsion-free constraint is, in the best case, unnecessary.

On the other hand, if the field equation for a some field ϕ can be solved algebraically as $\phi = f(\psi)$ in terms of the other fields, then by the implicit function theorem, the reduced action principle $I[\phi, \psi]$ is identical to the one obtained by substituting $f(\psi)$ in the action, $I[f(\psi), \psi]$. This occurs in 3 and 4 dimensions, where the spin connection can be algebraically obtained from its own field equation and $I[\omega, e] = I[\omega(e, \partial e), e]$. In higher dimensions, however, the torsion-free condition is not necessarily a consequence of the field equations and although (4.10) is algebraic in ω , it is practically impossible to solve for ω as a function of e . Therefore, it is not clear in general whether the action $I[\omega, e]$ is equivalent to the second order form of the LL action, $I[\omega(e, \partial e), e]$.

Since the torsion-free condition cannot be always obtained from the field equations, it is natural to look for a generalization of the Lanczos-Lovelock action in which torsion is not assumed to vanish. This generalization consists of adding of all possible Lorentz invariants involving T^a explicitly (this includes the combination $DT^a = R^{ab}e_b$). The general construction was worked out in [29]. The main difference with the torsion-free case is that now, together with the dimensional continuation of the Euler densities, one encounters the Pontryagin (or Chern classes) as well.

For $D = 3$, the only new torsion term not included in the Lovelock family is

$$e^a T_a, \quad (4.13)$$

while for $D = 4$, there are three terms not included in the LL series,

$$e^a e^b R_{ab}, T^a T_a, R^{ab} R_{ab}. \quad (4.14)$$

The last term in (4.14) is the Pontryagin density, whose integral also yields a topological invariant. It turns out that a linear combination of the other two terms is also a topological invariant related to torsion known as the Nieh-Yan density[30]

$$N_4 = T^a T_a - e^a e^b R_{ab}. \quad (4.15)$$

The properly normalized integral of (4.15) over a 4-manifold is an integer [31].

In general, the terms related to torsion that can be added to the action are combinations of the form

$$A_{2n} = e_{a_1} R_{a_2}^{a_1} R_{a_3}^{a_2} \cdots R_{a_n}^{a_{n-1}} e^{a_n}, \text{ even } n \geq 2 \quad (4.16)$$

$$B_{2n+1} = T_{a_1} R_{a_2}^{a_1} R_{a_3}^{a_2} \cdots R_{a_n}^{a_{n-1}} e^{a_n}, \text{ any } n \geq 1 \quad (4.17)$$

$$C_{2n+2} = T_{a_1} R_{a_2}^{a_1} R_{a_3}^{a_2} \cdots R_{a_n}^{a_{n-1}} T^{a_n}, \text{ odd } n \geq 1 \quad (4.18)$$

which are $2n$, $2n + 1$ and $2n + 2$ forms, respectively. These Lorentz invariants belong to the same family with the Pontryagin densities or Chern classes,

$$P_{2n} = R_{a_2}^{a_1} R_{a_3}^{a_2} \cdots R_{a_1}^{a_n}, \text{ even } n \geq 2. \quad (4.19)$$

The lagrangians that can be constructed now are much more varied and there is no uniform expression that can be provided for all dimensions. For example, in 8 dimensions, in addition to the LL terms, one has all possible 8-form made by taking products among the elements of the set $\{A_4, A_8, B_3, B_5, B_7, C_4, C_8, P_4, P_8\}$. They are

$$(A_4)^2, A_8, (B_3 B_5), (A_4 C_4), (C_4)^2, C_8, (A_4 P_4), (C_4 P_4), (P_4)^2, P_8. \quad (4.20)$$

To make life even more complicated, there are some linear combinations of these products which are topological densities. In 8 dimensions these are the Pontryagin forms

$$P_8 = R_{a_2}^{a_1} R_{a_3}^{a_2} \cdots R_{a_1}^{a_4},$$

$$(P_4)^2 = (R_b^a R_a^b)^2,$$

which occur also in the absence of torsion, and generalizations of the Nieh-Yan forms,

$$(N_4)^2 = (T^a T_a - e^a e^b R_{ab})^2,$$

$$N_4 P_4 = (T^a T_a - e^a e^b R_{ab})(R_d^c R_c^d),$$

etc. (for details and extensive discussions, see Ref.[29]).

5. Selecting Sensible Theories

Looking at these expressions one can easily get depressed. The lagrangians look awkward, the number of terms in them grow wildly with the dimension⁷. This problem is not only an aesthetic one. The coefficients in front of each term in the lagrangian is arbitrary and dimensionful. This problem already occurs in 4 dimensions, where the cosmological constant has dimensions of $[\text{length}]^{-4}$, and as evidenced by the outstanding cosmological constant problem, there is no theoretical argument to fix its value in order to compare with the observations.

There is another serious objection from the point of view of quantum mechanics. Dimensionful parameters in the action are potentially dangerous because they are likely to give rise to uncontrolled quantum corrections. This is what makes ordinary gravity nonrenormalizable in perturbation theory: In 4 dimensions, Newton's constant has dimensions of length squared, or inverse mass squared, in natural units. This means that as the order in perturbation theory increases, more powers of momentum will occur in the Feynman graphs, making its divergences increasingly worse. Concurrently, the radiative corrections to these bare parameters

⁷As it is shown in [29], the number of torsion-dependent terms grows as the partitions of $D/4$, which is given by the Hardy-Ramanujan formula, $p(D/4) \sim \frac{1}{\sqrt{3D}} \exp[\pi\sqrt{D/6}]$.

would require the introduction of infinitely many counterterms into the action to render them finite[32]. But an illness that requires infinite amount of medication is also incurable.

The only safeguard against the threat of uncontrolled divergences in the quantum theory is to have some symmetry principle that fixes the values of the parameters in the action and limits the number of possible counterterms that could be added to the lagrangian. Thus, if one could find a symmetry argument to fix the independent parameters in the theory, these values will be “protected” by the symmetry. A good indication that this might happen would be if the coupling constants are all dimensionless, as in Yang-Mills theory.

As we will see in odd dimensions there is a unique combination of terms in the action that can give the theory an enlarged symmetry, and the resulting action can be seen to depend on a unique constant that multiplies the action. Moreover, this constant can be shown to be quantized by a argument similar to Dirac’s quantization of the product of magnetic and electric charge [38].

5.1 Extending the Lorentz Group

The coefficients α_p in the LL lagrangian (4.5) have dimensions l^{D-2p} . This is because the canonical dimension of the vielbein is $[e^a] = l^1$, while the Lorentz connection has dimensions that correspond to a true gauge field, $[\omega^{ab}] = l^0$. This reflects the fact that gravity is naturally only a gauge theory for the Lorentz group, where the vielbein plays the role of a matter field, which is not a connection field but transforms as a vector under Lorentz rotations.

Three-dimensional gravity is an important exception to this statement, in which case e^a plays the role of a connection. Consider the simplest LL lagrangian in 3 dimensions, the Einstein-Hilbert term

$$L_3 = \epsilon_{abc} R^{ab} e^c. \quad (5.1)$$

Under an infinitesimal Lorentz transformation with parameter λ^a_b , ω^{ab} transforms as

$$\begin{aligned} \delta\omega^a_b &= D\lambda^a_b \\ &= d\lambda^a_b + \omega^a_c \lambda^c_b - \omega^c_b \lambda^a_c, \end{aligned} \quad (5.2)$$

while e^c , R^{ab} and ϵ_{abc} transform as tensors,

$$\begin{aligned} \delta e^a &= \lambda^a_c e^c \\ \delta R^{ab} &= \lambda^a_c R^{cb} + \lambda^b_c R^{ac}, \\ \delta \epsilon_{abc} &= \lambda^d_a \epsilon_{dbc} + \lambda^d_b \epsilon_{adc} + \lambda^d_c \epsilon_{abd}. \end{aligned}$$

Combining these relations the Lorentz invariance of L_3 can be shown directly. What is unexpected is that one can view e^a as a gauge connection for the translation group. In fact, if under “local translations” in tangent space, parametrized by λ^a , the vielbein transforms as a connection,

$$\begin{aligned} \delta e^a &= D\lambda^a \\ &= d\lambda^a + \omega^a_b \lambda^b, \end{aligned} \quad (5.3)$$

the lagrangian L_3 changes by a total derivative,

$$\delta L_3 = d[\epsilon_{abc} R^{ab} \lambda^c]. \quad (5.4)$$

Thus, the action changes by a surface term which can be dropped under standard boundary conditions. This means that, in three dimensions, ordinary gravity can be viewed as a gauge theory of the Poincaré group. We leave it as an exercise to the reader to prove this. (Hint: use the infinitesimal transformations δe and $\delta \omega$ to compute the commutators of the second variations to obtain the Lie algebra of the Poincaré group.)

The miracle also works in the presence of a cosmological constant $\Lambda = \mp \frac{1}{6l^2}$. Now the lagrangian (4.5) is

$$L_3^{AdS} = \epsilon_{abc} (R^{ab} e^c \pm \frac{1}{3l^2} e^a e^b e^c), \quad (5.5)$$

and the action is invariant –modulo surface terms– under the infinitesimal transformations,

$$\delta \omega^{ab} = [d\lambda^{ab} + \omega_c^a \lambda^{cb} + \omega_c^b \lambda^{ac}] \mp \frac{1}{l^2} [e^a \lambda^b - \lambda^a e^b] \quad (5.6)$$

$$\delta e^a = [\lambda_b^a e^b] + [d\lambda^a + \omega_b^a \lambda^b]. \quad (5.7)$$

These transformations can be cast in a more suggestive way as

$$\begin{aligned} \delta \begin{bmatrix} \omega^{ab} & l^{-1} e^a \\ -l^{-1} e^b & 0 \end{bmatrix} &= d \begin{bmatrix} \lambda^{ab} & l^{-1} \lambda^a \\ -l^{-1} \lambda^b & 0 \end{bmatrix} + \begin{bmatrix} \omega_c^a & \pm l^{-1} e^a \\ -l^{-1} e_c & 0 \end{bmatrix} \begin{bmatrix} \lambda^{cb} & l^{-1} \lambda^c \\ -l^{-1} \lambda^b & 0 \end{bmatrix} \\ &+ \begin{bmatrix} \omega_c^b & \pm l^{-1} e^b \\ -l^{-1} e_c & 0 \end{bmatrix} \begin{bmatrix} \lambda^{ac} & l^{-1} \lambda^a \\ -l^{-1} \lambda^c & 0 \end{bmatrix}. \end{aligned}$$

This can also be written as

$$\delta W^{AB} = dW^{AB} + W_C^A \Lambda^{CB} + W_C^B \Lambda^{AC},$$

where the 1-form W^{AB} and the 0-form Λ^{AB} stand for the combinations

$$W^{AB} = \begin{bmatrix} \omega^{ab} & l^{-1} e^a \\ -l^{-1} e^b & 0 \end{bmatrix} \quad (5.8)$$

$$\Lambda^{AB} = \begin{bmatrix} \lambda^{ab} & l^{-1} \lambda^a \\ -l^{-1} \lambda^b & 0 \end{bmatrix}, \quad (5.9)$$

where $a, b, \dots = 1, 2, \dots, D$, while $A, B, \dots = 1, 2, \dots, D+1$. Clearly, W^{AB} transforms as a connection and Λ^{AB} can be identified as the infinitesimal transformation parameters, but for which group? A clue comes from the fact that $\Lambda^{AB} = -\Lambda^{BA}$. This immediately indicates that the group is one that leaves invariant a symmetric, real bilinear form, so it must be one of the $SO(r, s)$ family. The signs (\pm) in the transformation above can be traced back to the sign of

the cosmological constant. It is easy to check that this structure fits well if indices are raised and lowered with the metric

$$\Pi^{AB} = \begin{bmatrix} \eta^{ab} & 0 \\ 0 & \pm 1 \end{bmatrix}, \quad (5.10)$$

so that, for example, $W^A_B = \Pi_{BC}W^{AC}$. Then, the covariant derivative in the connection W of this metric vanishes identically,

$$D_W \Pi^{AB} = d\Pi^{AB} + W^A_C \Pi^{CB} + W^B_C \Pi^{AC} = 0. \quad (5.11)$$

Since Π^{AB} is constant, this last expression implies $W^{AB} + W^{BA} = 0$, in exact analogy with what happens with the Lorentz connection, $\omega^{ab} + \omega^{ba} = 0$, where $\omega^{ab} = \eta^{bc}\omega^a_c$. Indeed, this is a very awkward way to discover that the 1-form W^{AB} is actually a connection for the group which leaves invariant the metric Π^{AB} . Here the two signs in Π^{AB} correspond to the de Sitter (+) and anti-de Sitter (−) groups, respectively.

Observe that what we have found here is an explicit way to immerse the Lorentz group into a larger one, in which the vielbein has been promoted to a component of a larger connection, on the same footing as the Lorentz connection.

The Poincaré symmetry is obtained in the limit $l \rightarrow \infty$. In that case, instead of (5.6, 5.7) one has

$$\delta\omega^{ab} = [d\lambda^{ab} + \omega^a_c \lambda^{cb} + \omega^b_c \lambda^{ac}] \quad (5.12)$$

$$\delta e^a = [\lambda^a_b e^b] + [d\lambda^a + \omega^a_b \lambda^b]. \quad (5.13)$$

In this limit, the representation in terms of W becomes inadequate because the metric Υ^{AB} becomes degenerate (noninvertible) and is not clear how to raise and lower indices anymore.

5.2 More Dimensions

Everything that has been said about the embedding of the Lorentz group into the (A)dS group, starting at equation (5.6) is not restricted to $D = 3$ only and can be done in any D . In fact, it is always possible to embed the Lorentz group in D dimensions into the de-Sitter, or anti-de Sitter groups,

$$SO(D-1, 1) \hookrightarrow \begin{cases} SO(D, 1), & \Pi^{AB} = \text{diag}(\eta^{ab}, +1) \\ SO(D-1, 2), & \Pi^{AB} = \text{diag}(\eta^{ab}, -1) \end{cases}. \quad (5.14)$$

with the corresponding Poincaré limit, which is the familiar symmetry group of Minkowski space.

$$SO(D-1, 1) \hookrightarrow ISO(D-1, 1). \quad (5.15)$$

Then, the question naturally arises: can one find an action for gravity in other dimensions which is also invariant, not just under the Lorentz group, but under one of its extensions, $SO(D, 1)$, $SO(D-1, 2)$, $ISO(D-1, 1)$? As we will see now, the answer to this question is affirmative in odd dimensions. There is always a action for $D = 2n - 1$, invariant under local

$SO(2n - 2, 2)$, $SO(2n - 1, 1)$ or $ISO(2n - 2, 1)$ transformations, in which the vielbein and the spin connection combine to form the connection of the larger group. In even dimensions, however, this cannot be done.

Why is it possible in three dimensions to enlarge the symmetry from local $SO(2, 1)$ to local $SO(3, 1)$, $SO(2, 2)$, $ISO(2, 1)$? What happens if one tries to do this in four or more dimensions? Let us start with the Poincaré group and the Hilbert action for $D = 4$,

$$L_4 = \epsilon_{abcd} R^{ab} e^c e^d. \quad (5.16)$$

Why is this not invariant under local translations $\delta e^a = d\lambda^a + \omega^a_b \lambda^b$? A simple calculation yields

$$\begin{aligned} \delta L_4 &= 2\epsilon_{abcd} R^{ab} e^c \delta e^d \\ &= d(2\epsilon_{abcd} R^{ab} e^c \lambda^d) + 2\epsilon_{abcd} R^{ab} T^c \lambda^d. \end{aligned} \quad (5.17)$$

The first term in the r.h.s. of (5.17) is a total derivative and therefore gives a surface contribution to the action. The last term, however, need not vanish, unless one imposes the field equation $T^a = 0$. But this means that the invariance of the action only occurs on shell. On shell symmetries are not real symmetries and they need not survive quantization. On close inspection, one observes that the miracle occurred in 3 dimensions because the lagrangian contained only one e . This means that a lagrangian of the form

$$L_{2n+1} = \epsilon_{a_1 \dots a_{2n+1}} R^{a_1 a_2} \dots R^{a_{2n-1} a_{2n}} e^{a_{2n+1}} \quad (5.18)$$

is invariant under local Poincaré transformations (5.12, 5.13), as can be easily checked out. Since the Poincaré group is a limit of (A)dS, it seem likely that there should exist a lagrangian in odd dimensions, invariant under local (A)dS transformations, whose limit for $l \rightarrow \infty$ (vanishing cosmological constant) is (5.18). One way to find out what that lagrangian might be, one could take the most general LL lagrangian and select the coefficients by requiring invariance under (5.6, 5.7). This is a long, tedious and sure route. An alternative approach is to try to understand why it is that in three dimensions the gravitational lagrangian with cosmological constant (5.5) is invariant under the (A)dS group.

If one takes seriously the notion that W^{AB} is a connection, then one can compute the associated curvature,

$$F^{AB} = dW^{AB} + W^A_C W^{CB},$$

using the definition of W^{AB} (5.8). It is a simple exercise to prove

$$F^{AB} = \begin{bmatrix} R^{ab} \pm l^{-2} e^a e^b & l^{-1} T^a \\ -l^{-1} T^b & 0 \end{bmatrix}. \quad (5.19)$$

If a, b run from 1 to 3 and A, B from 1 to 4, then one can construct the 4-form invariant under the (A)dS group,

$$E_4 = \epsilon_{ABCD} F^{AB} F^{CD}, \quad (5.20)$$

which is readily recognized as the Euler density in a four-dimensional manifold whose tangent space is not Minkowski, but has the metric $\Pi^{AB} = \text{diag}(\eta^{ab}, \mp 1)$. E_4 can also be written explicitly in terms of R^{ab} , T^a , and e^a ,

$$\begin{aligned} E_4 &= 4\epsilon_{abc}(R^{ab} \pm l^{-2}e^ae^b)l^{-1}T^a \\ &= \frac{4}{l}d\left[\epsilon_{abc}\left(R^{ab} \pm \frac{1}{3l^2}e^ae^b\right)e^a\right], \end{aligned} \quad (5.21)$$

which is, up to constant factors, the exterior derivative of the three-dimensional lagrangian (5.5),

$$E_4 = \frac{4}{l}dL_3^{AdS}. \quad (5.22)$$

This explains why the action is (A)dS invariant up to surface terms: the l.h.s. of (5.22) is invariant by construction under local (A)dS, so the same must be true of the r.h.s., $\delta(dL_3^{AdS}) = 0$. Since the variation (δ) is a linear operation,

$$d\left(\delta L_3^{AdS}\right) = 0,$$

which in turn means, by Poincaré's Lemma that, locally, $\delta L_3^{AdS} = d(\text{something})$. That is exactly what we found for the variation, [see, (5.4)]. The fact that three dimensional gravity can be written in this way was observed many years ago in Refs. [33, 34].

The key to generalize the (A)dS lagrangian from 3 to $2n - 1$ dimensions is now clear⁸. First, generalize the Euler density (5.20) to a $2n$ -form,

$$E_{2n} = \epsilon_{A_1 \dots A_{2n}} F^{A_1 A_2} \dots F^{A_{2n-1} A_{2n}}. \quad (5.23)$$

Second, express E_{2n} explicitly in terms of R^{ab} , T^a , and e^a , and write this as the exterior derivative of a $(2n - 1)$ -form which can be used as a lagrangian in $(2n - 1)$ dimensions. Direct computation yields the $(2n - 1)$ - dimensional lagrangian as

$$L_{2n-1}^{(A)dS} = \sum_{p=0}^{n-1} \bar{\alpha}_p L^{(2n-1,p)}, \quad (5.24)$$

where $L^{(D,p)}$ is given by (4.2) and the coefficients $\bar{\alpha}_p$ are no longer arbitrary, but they take the values

$$\bar{\alpha}_p = \kappa \cdot \frac{(\pm 1)^{p+1} l^{2p-D}}{(D-2p)} \binom{n-1}{p}, \quad p = 1, 2, \dots, n-1 = \frac{D-1}{2}, \quad (5.25)$$

where κ is an arbitrary dimensionless constant. It is left as an exercise to the reader to check that $dL_{2n-1}^{(A)dS} = E_{2n}$ and to show the invariance of $L_{2n-1}^{(A)dS}$ under the (A)dS group. In five dimensions, for example, the (A)dS lagrangian reads

$$L_5^{(A)dS} = \kappa \cdot \epsilon_{abcde} \left[\frac{1}{l} e^a R^{bc} R^{de} \pm \frac{2}{3l^3} e^a e^b e^c R^{de} + \frac{1}{5l^5} e^a e^b e^c e^d e^e \right]. \quad (5.26)$$

⁸The construction we outline here was discussed by Chamseddine [35], Müller-Hoissen [36], and Bañados, Teitelboim and this author in [40].

The parameter l is a length scale –the Planck length– and cannot be fixed by other considerations. Actually, l only appears in the combination

$$\tilde{e}^a = \frac{e^a}{l},$$

which could be considered as the “true” dynamical field, which is the natural thing to do if one uses W^{AB} instead of ω^{ab} and e^a separately. In fact, the lagrangian (5.24) can also be written in terms of W^{AB} and its exterior derivative, as

$$L_{2n-1}^{(A)dS} = \kappa \cdot \epsilon_{A_1 \dots A_{2n}} [W(dW)^{n-1} + a_3 W^3 (dW)^{n-2} + \dots a_{2n-1} W^{2n-1}], \quad (5.27)$$

where all indices are contracted appropriately and the coefficients a_3, a_5, \dots are all combinatoric factors without dimensions.

The only remaining free parameter is κ . Suppose this lagrangian is used to describe a simply connected, compact $2n - 1$ dimensional manifold M , which is the boundary of a $2n$ -dimensional compact orientable manifold Ω . Then the action for the geometry of M can be expressed as the integral of the Euler density E_{2n} over Ω , multiplied by κ . But since there can be many different manifolds with the same boundary M , the integral over Ω should give the physical predictions as that over another manifold, Ω' . In order for this change to leave the path integral unchanged, a minimal requirement would be

$$\kappa \left[\int_{\Omega} E_{2n} - \int_{\Omega'} E_{2n} \right] = 2n\pi\hbar. \quad (5.28)$$

The quantity in brackets –with right normalization– is the Euler number of the manifold obtained by gluing Ω and Ω' along M , in the right way to produce an orientable manifold, $\chi[\Omega \cup \Omega']$, which can take an arbitrary integer value. From this, one concludes that κ must be quantized[38],

$$\kappa = nh.$$

where h is Planck’s constant.

5.3 Chern-Simons

There is a more general way to look at these lagrangians in odd dimensions, which also sheds some light on their remarkable enlarged symmetry. This is summarized in the following

Lemma: Let $C(F)$ be an invariant $2n$ -form constructed with the field strength $F = dA + A^2$, where A is the connection for some gauge group G . If there exists a $2n - 1$ form, L , depending on A and dA , such that $dL = C$, then under a gauge transformation, L changes by a total derivative (exact form).

The $(2n - 1)$ –form L is known as the Chern-Simons (**CS**) lagrangian. This lemma shows that L defines a nontrivial lagrangian for A which is *not invariant* under gauge transformations, but that changes by a function that only depends on the fields at the boundary.

This construction is not only restricted to the Euler invariant discussed above, but applies to any invariant of similar nature, generally known as characteristic classes. Other well known

characteristic classes are the Pontryagin or Chern classes and their corresponding CS forms were studied first in the context of abelian and nonabelian gauge theories (see, e. g., [39, 6]).

The following table gives examples of CS forms which define lagrangians in three dimensions, and their corresponding characteristic classes,

Lagrangian	CS formL	dL
L_3^{Lor}	$\omega_b^a d\omega_a^b + \frac{2}{3}\omega_b^a \omega_c^b \omega_a^c$	$R_b^a R_a^b$
L_3^{Tor}	$e^a T_a$	$T^a T_a - e^a e^b R_{ab}$
$L_3^{U(1)}$	AdA	FF
$L_3^{SU(N)}$	$tr[\mathbf{A}d\mathbf{A} + \frac{2}{3}\mathbf{A}\mathbf{A}\mathbf{A}]$	$tr[\mathbf{F}\mathbf{F}]$

In this table, R , F , and \mathbf{F} are the curvatures of the Lorentz connection ω_b^a , the electromagnetic ($U(1)$) connection A , and the Yang-Mills ($SU(N)$) connection \mathbf{A} , respectively.

5.4 Torsional CS

So far we have not included torsion in the CS lagrangians, but as we see in the third row of the table above it is also possible to construct CS forms that include torsion. All the CS forms above are Lorentz invariant up to a closed form, but there is a linear combination of the first two which is invariant under the (A)dS group. The so-called exotic gravity, given by

$$L_3^{Exotic} = L_3^{Lor} + \frac{2}{l^2} L_3^{Tor}, \quad (5.29)$$

is invariant under (A)dS, as can be shown by computing its exterior derivative,

$$\begin{aligned} dL_3^{Exotic} &= R_b^a R_a^b \pm \frac{2}{l^2} (T^a T_a - e^a e^b R_{ab}) \\ &= F_B^A F_A^B. \end{aligned}$$

This exotic lagrangian has the curious property of giving exactly the same field equations as the standard dL_3^{AdS} , but interchanged: the equation for e^a form one is the equation for ω^{ab} of the other. In five dimensions there are no new terms due to torsion, and in seven there are three torsional CS terms,

Lagrangian	CS formL	dL
L_7^{Lor}	$\omega(d\omega)^3 + \dots + \frac{4}{7}\omega^7$	$R_b^a R_c^b R_d^c R_a^d$
$L_3^{Lor} R_b^a R_a^b$	$(\omega_b^a d\omega_a^b + \frac{2}{3}\omega_b^a \omega_c^b \omega_a^c) R_b^a R_a^b$	$(R_b^a R_a^b)^2$
$L_3^{Tor} R_b^a R_a^b$	$e^a T_a R_b^a R_a^b$	$(T^a T_a - e^a e^b R_{ab}) R_b^a R_a^b$

In three spacetime dimensions, GR is a renormalizable quantum theory [34]. It is strongly suggestive that precisely in 2+1 dimensions this is also a gauge theory on a fiber bundle. It could be thought that the exact solvability miracle is due to the absence of propagating degrees of freedom in three-dimensional gravity, but the final power-counting argument of renormalizability rests on the fiber bundle structure of the Chern-Simons system and doesn't seem to depend on the absence of propagating degrees of freedom.

5.5 Even Dimensions

The CS construction fails in $2n$ dimensions for the simple reason that there are no characteristic classes $C(F)$ constructed with products of curvature in $2n + 1$ dimensions. This is why an action for gravity in even dimensions cannot be invariant under the (anti-) de Sitter or Poincaré groups. In this light, it is fairly obvious that although ordinary Einstein-Hilbert gravity can be given a fiber bundle structure for the Lorentz group, this structure cannot be extended to include local translational invariance.

In some sense, the closest one can get to a CS theory in even dimensions is the so-called Born-Infeld (**BI**) theories [37, 40, 41]. The BI lagrangian is obtained by a particular choice of the α_p s in the LL series, so that the lagrangian takes the form

$$L_{2n}^{BI} = \epsilon_{a_1 \dots a_{2n}} \bar{R}^{a_1 a_2} \dots \bar{R}^{a_{2n-1} a_{2n}}, \quad (5.30)$$

where \bar{R}^{ab} stands for the combination

$$\bar{R}^{ab} = R^{ab} \pm \frac{1}{l^2} e^a e^b. \quad (5.31)$$

With this definition it is clear that the lagrangian (5.30) contains only one free parameter, l . This lagrangian has a number of interesting classical features like simple equations, black hole solutions, cosmological models, etc. The simplification comes about because the equations admit a unique maximally symmetric configuration given by $\bar{R}^{ab} = 0$, in contrast with the situation when all α_p s are arbitrary. As we have mentioned, for arbitrary α_p s, the field equations do not determine completely the components of R^{ab} and T^a in general. This is because the high nonlinearity of the equations can give rise to degeneracies. The BI choice is in this respect the best behaved since the degeneracies are restricted to only one value of the radius of curvature ($R^{ab} \pm \frac{1}{l^2} e^a e^b = 0$). At the same time, the BI action has the least number of algebraic constraints required by consistency among the field equations, and it is therefore the one with the simplest dynamical behavior[41].

Equipped with the tools to construct gravity actions invariant under larger groups, in the next lecture we undertake the extension of this trick to include supersymmetry.

LECTURE 3

CHERN SIMONS SUPERGRAVITY

The previous lectures dealt with the possible ways in which pure gravity can be extended by relaxing three standard assumptions of General Relativity: **i**) that the notion of parallelism is derived from metricity, **ii**) that the dimension of spacetime must be four, and **iii**) that the action should only contain the Einstein Hilbert term $\sqrt{g}R$. On the other hand, we still demanded that **iv**) the metric components obey second order field equations, **v**) the lagrangian be an D -form constructed out of the vielbein, e^a , the spin connection, ω_b^a , and

their exterior derivatives, **vi**) the action be invariant under local Lorentz rotations in the tangent space. This allowed for the inclusion of several terms containing higher powers of the curvature and torsion multiplied by arbitrary and dimensionful coefficients. The presence of these arbitrary constants was regarded as a bit of an embarrassment which could be cured by enlarging the symmetry group, thereby fixing all parameters in the lagrangian and making the theory gauge invariant under the larger symmetry group. The cure works in odd but not in even dimensions. The result was a highly nonlinear Chern-Simons theory of gravity, invariant under local AdS transformations in the tangent space. We now turn to the problem of enlarging the contents of the theory to allow for supersymmetry.

6. Supersymmetry

Supersymmetry is a symmetry most theoreticians are willing to accept as a legitimate feature of nature, although it has never been experimentally observed. The reason is that it is such a unique and beautiful idea that it is commonly felt that it would be a pity if it is not somehow realized in nature. Supersymmetry is the only symmetry which can accommodate spacetime and internal symmetries in a nontrivial way. By nontrivial we mean that the Lie algebra *is not* a direct sum of the algebras of spacetime and internal symmetries. There is a famous no-go theorem which states that it is impossible to do this with an ordinary Lie group, closed under commutator (antisymmetric product, $[\cdot, \cdot]$). The way supersymmetry circumvents this obstacle is by having both commutators and anticommutators (symmetric product, $\{\cdot, \cdot\}$), forming what is known as a **graded Lie algebra**, also called a super Lie algebra or simply, a superalgebra. For a general introduction to supersymmetry, see [43, 44].

The importance of this unification is that it combines bosons and fermions on the same footing. Bosons are the carriers of interactions, such as the photon, the graviton and gluons, while fermions are the constituents of matter, such as electrons and quarks. Thus, supersymmetry predicts the existence of a fermionic carriers of interaction and bosonic constituents of matter as partners of the known particles, none of which have been observed.

Supersymmetry also strongly restricts the possible theories of nature and in some cases it even predicts the dimension of spacetime, like in superstring theory as seen in the lectures by Stefan Theisen in this same volume [42].

6.1 Superalgebra

A superalgebra has two types of generators: bosonic, \mathbf{B}_i , and fermionic, \mathbf{F}_α . They are closed under the (anti-) commutator operation, which follows the general pattern

$$[\mathbf{B}_i, \mathbf{B}_j] = C_{ij}^k \mathbf{B}_k \tag{6.1}$$

$$[\mathbf{B}_i, \mathbf{F}_\alpha] = C_{i\alpha}^\beta \mathbf{F}_\beta \tag{6.2}$$

$$\{\mathbf{F}_\alpha, \mathbf{F}_\beta\} = C_{\alpha\beta}^\gamma \mathbf{B}_\gamma \tag{6.3}$$

The generators of the Poincaré group are included in the bosonic sector, and the \mathbf{F}_α 's are the supersymmetry generators. This algebra, however, does not close for an arbitrary bosonic

group. In other words, given a Lie group with a set of bosonic generators, it is not always possible to find a set of fermionic generators to enlarge the algebra into a closed superalgebra. The operators satisfying relations of the form (6.1-6.3), are still required to satisfy a consistency condition, the super-Jacobi identity,

$$[\mathbf{G}_\mu, [\mathbf{G}_\nu, \mathbf{G}_\lambda]_{\pm}]_{\pm} + (-)^{\sigma(\nu\lambda\mu)} [\mathbf{G}_\nu, [\mathbf{G}_\lambda, \mathbf{G}_\mu]_{\pm}]_{\pm} + (-)^{\sigma(\lambda\mu\nu)} [\mathbf{G}_\lambda, [\mathbf{G}_\mu, \mathbf{G}_\nu]_{\pm}]_{\pm} = 0. \quad (6.4)$$

Here \mathbf{G}_μ represents any generator in the algebra, $[R, S]_{\pm} = RS \pm SR$, where this sign is chosen according the bosonic or fermionic nature of the operators in the bracket, and $\sigma(\nu\lambda\mu)$ is the number of permutations of fermionic generators.

As we said, starting with a set of bosonic operators it is not always possible to find a set of N fermionic ones that generate a closed superalgebra. It is often the case that extra bosonic generators are needed to close the algebra, and this usually works for some values of N only. In other cases there is simply no supersymmetric extension at all. This happens, for example, with the de Sitter group, which has no supersymmetric extension in general [44]. For this reason in what follows we will restrict to AdS theories.

6.2 Supergravity

The name supergravity (**SUGRA**) applies to any of a number of supersymmetric theories that include gravity in their bosonic sectors. The invention/discovery of supergravity in the mid 70's came about with the spectacular announcement that some ultraviolet divergent graphs in pure gravity were cancelled by the inclusion of their supersymmetric partners [45]. For some time it was hoped that the nonrenormalizability of GR could be cured in this way by its supersymmetric extension. However, the initial hopes raised by SUGRA as a way taming the ultraviolet divergences of pure gravity eventually vanished with the realization that SUGRAs would be nonrenormalizable as well [46].

Again, one can see that the standard form of SUGRA is not a gauge theory for a group or a supergroup, and that the local (super-) symmetry algebra closes naturally on shell only. The algebra could be made to close off shell by force, at the cost of introducing auxiliary fields –which are not guaranteed to exist for all d and N [47]–, and still the theory would not have a fiber bundle structure since the base manifold is identified with part of the fiber. Whether it is the lack of fiber bundle structure the ultimate reason for the nonrenormalizability of gravity remains to be proven. It is certainly true, however, that if GR could be formulated as a gauge theory, the chances for its renormalizability would clearly increase. At any rate, now most high energy physicists view supergravity as an effective theory obtained from string theory in some limit. In string theory, eleven dimensional supergravity is seen as an effective theory obtained from ten dimensional string theory at strong coupling [42]. In this sense supergravity would not be a fundamental theory and therefore there is no reason to expect that it should be renormalizable.

In any case, our point of view here is that there can be more than one system that can be called supergravity, whose connection with the standard theory is still not clear. As we

have seen in the previous lecture, the CS gravitation theories in odd dimensions are genuine (off-shell) gauge theories for the anti-de Sitter (**A**)dS or Poincaré groups.

6.3 From Rigid Supersymmetry to Supergravity

Rigid or global SUSY is a supersymmetry in which the group parameters are constants throughout spacetime. In particle physics the spacetime is usually assumed to have fixed Minkowski geometry. Then the relevant SUSY is the supersymmetric extension of the Poincaré algebra in which the supercharges are “square roots” of the generators of spacetime translations, $\{\bar{\mathbf{Q}}, \mathbf{Q}\} \sim \Gamma \cdot \mathbf{P}$. The extension of this to a local symmetry can be done by substituting the momentum $\mathbf{P}_\mu = i\partial_\mu$ by the generators of spacetime diffeomorphisms, \mathbb{H}_μ , and relating them to the supercharges by $\{\bar{\mathbf{Q}}, \mathbf{Q}\} \sim \Gamma \cdot \mathbb{H}$. The resulting theory has a local supersymmetry algebra which only closes on-shell [45]. As we discussed above, the problem with on-shell symmetries is that they are not likely to survive in the quantum theory.

Here we consider the alternative approach of extending the AdS symmetry on the tangent space into a supersymmetry rather than working directly on the spacetime manifold. This point of view is natural if one recalls that spinors are naturally defined relative to a local frame on the tangent space rather than to the coordinate basis. In fact, spinors provide an irreducible representation for $SO(N)$, but not for $GL(N)$, which describe infinitesimal general coordinate transformations. The basic strategy is to reproduce the 2+1 “miracle” in higher dimensions. This idea was applied in five dimensions[35], as well as in higher dimensions [48, 49, 50].

6.4 Assumptions of Standard Supergravity

Three implicit assumptions are usually made in the construction of standard SUGRA:

(i) The fermionic and bosonic fields in the Lagrangian should come in combinations such that they have equal number of propagating degrees of freedom. This is usually achieved by adding to the graviton and the gravitini a number of fields of spins 0, 1/2 and 1 [45]. This matching, however, is not necessarily true in AdS space, nor in Minkowski space if a different representation of the Poincaré group (e.g., the adjoint representation) is used [43].

The other two assumptions concern the purely gravitational sector and are dictated by economy:

(ii) gravitons are described by the Hilbert action (plus a possible cosmological constant), and,

(iii) the spin connection and the vielbein are not independent fields but are related through the torsion equation.

The fact that the supergravity generators do not form a closed off-shell algebra can be traced back to these assumptions.

The argument behind (i) is closely related to the idea that the fields should be in a vector representation of the Poincaré group. This assumption comes from the interpretation of supersymmetric states as represented by the in- and out- plane waves in an asymptotically free, weakly interacting theory in a Minkowski background. Then, because the hamiltonian

commutes with the supersymmetry generators, every nonzero mass state must have equal number of bosonic and fermionic states: For each bosonic state of energy, $|E \rangle_B$, there is a fermionic one with the same energy, $|E \rangle_F = \mathbf{Q} |E \rangle_B$, and vice versa. This argument, however, breaks down if the Poincaré group is not a symmetry of the theory, as it happens in an asymptotically AdS space, and in other simple cases such as SUSY in 1+1, with broken translational invariance [51].

Also implicit in the argument for counting the degrees of freedom is the usual assumption that the kinetic terms and couplings are those of a minimally coupled gauge theory, a condition that is not met by a CS theory. Apart from the difference in background, which requires a careful treatment of the unitary irreducible representations of the asymptotic symmetries [52], the counting of degrees of freedom in CS theories is completely different from the counting for the same connection 1-forms in a YM theory (see Lecture 4 below).

7. Super AdS algebras

In order to construct a supergravity theory that contains gravity with a cosmological constant, a mathematically oriented physicist would look for the smallest superalgebra that contains the generators of the AdS algebra. This was asked –and answered!– many years ago, at least for some dimensions $D = 2, 3, 4 \pmod 8$, [54]. However this is not all, we would also want to see an action that realizes the symmetry. Constructing a supergravity action for a given dimension that includes a cosmological constant is a nontrivial task. For example, the standard supergravity in eleven dimensions has been known for a long time [55], however, it does not contain a cosmological constant term, and it has been shown to be impossible to accommodate one [56]. Moreover, although it was known to the authors of Ref.[55] that the supergroup that contains the AdS group in eleven dimensions is $SO(32|1)$, no action was found for almost twenty years for the theory of gravity which exhibits this symmetry.

An explicit representation of the superalgebras that contain AdS algebra $so(D-1, 2)$ can be constructed along the lines of [54], although here we consider an extension of this method which applies to the cases $D = 5, 7$, and 9 as well [49]. The crucial observation is that the Dirac matrices provide a natural representation of the AdS algebra in any dimension. Then, the AdS connection \mathbf{W} can be written in this representation as $\mathbf{W} = e^a \mathbf{J}_a + \frac{1}{2} \omega^{ab} \mathbf{J}_{ab}$, where

$$\mathbf{J}_a = \begin{bmatrix} \frac{1}{2}(\Gamma_a)^\alpha_\beta & 0 \\ 0 & 0 \end{bmatrix}, \quad (7.1)$$

$$\mathbf{J}_{ab} = \begin{bmatrix} \frac{1}{2}(\Gamma_{ab})^\alpha_\beta & 0 \\ 0 & 0 \end{bmatrix}. \quad (7.2)$$

Here Γ_a , $a = 1, \dots, D$ are $m \times m$ Dirac matrices, where $m = 2^{\lfloor D/2 \rfloor}$ (here $\lfloor r \rfloor$ denotes the integer part of r), and $\Gamma_{ab} = \frac{1}{2}[\Gamma_a, \Gamma_b]$. These two classes of matrices form a closed commutator subalgebra (the AdS algebra) of the **Dirac algebra** \mathcal{D} , obtained by taking antisymmetrized

products of $\mathbf{\Gamma}$ matrices

$$\mathbf{I}, \mathbf{\Gamma}_{a_1}, \mathbf{\Gamma}_{a_1 a_2}, \dots, \mathbf{\Gamma}_{a_1 a_2 \dots a_D}, \quad (7.3)$$

where $\mathbf{\Gamma}_{a_1 a_2 \dots a_k} = \frac{1}{k!}(\mathbf{\Gamma}_{a_1} \mathbf{\Gamma}_{a_2} \dots \mathbf{\Gamma}_{a_k} \pm [\text{permutations}])$. For even D these are all linearly independent, but for odd D they are not, because $\mathbf{\Gamma}_{12 \dots D} = \sigma \mathbf{I}$ and therefore half of them are proportional to the other half. Thus, the dimension of this algebra is $m^2 = 2^{2[D/2]}$ and not D^2 as one could naively think. This representation provides an elegant way to generate all $m \times m$ matrices (note however, that $m = 2^{[D/2]}$ is not any number).

7.1 The Fermionic Generators

The simplest extension of the matrices (7.1, 7.2) is obtained by the addition of one row and one column. The generators associated to these entries would have one on spinor index. Let us call \mathbf{Q}_γ the generator that has only one nonvanishing entry in the γ -th row of the last column,

$$\mathbf{Q}_\gamma = \begin{bmatrix} 0 & \delta_\gamma^\alpha \\ -C_{\gamma\beta} & 0 \end{bmatrix}. \quad (7.4)$$

Since this generator carries a spinorial index, we will assume it is in a spin 1/2 representation of the Lorentz group. The entries of the bottom row will be chosen so as to produce smallest supersymmetric extensions of adS. There are essentially two ways of reducing the representation compatible with Lorentz invariance: *chirality*, which corresponds to Weyl spinors, and *reality*, for *Majorana* spinors. A Majorana spinor satisfies a constraint that relates its components to those of its complex conjugate,

$$\bar{\psi}^\alpha = C^{\alpha\beta} \psi_\beta. \quad (7.5)$$

The charge conjugation matrix, $\mathbf{C} = (C^{\alpha\beta})$ is invertible, $C_{\alpha\beta} C^{\beta\gamma} = \delta_\alpha^\gamma$ and therefore, it can be used as a metric in the space of Majorana spinors. Since both $\mathbf{\Gamma}^a$ and $(\mathbf{\Gamma}^a)^\text{T}$ obey the same Clifford algebra ($\{\mathbf{\Gamma}^a, \mathbf{\Gamma}^b\} = 2\eta^{ab}$), there could be a representation in which the $(\mathbf{\Gamma}^a)^\text{T}$ is related to $\mathbf{\Gamma}^a$ by a change of basis up to a sign,

$$(\mathbf{\Gamma}^a)^\text{T} = \eta \mathbf{C} \mathbf{\Gamma}^a \mathbf{C}^{-1} \quad \text{with } \eta^2 = 1. \quad (7.6)$$

The Dirac matrices for which there is an operator \mathbf{C} satisfying (7.6) is called the Majorana representation⁹. This last equation is the defining relation for the charge conjugation matrix, and whenever it exists, it can be chosen to have definite parity,

$$\mathbf{C}^\text{T} = \lambda \mathbf{C}, \text{ with } \lambda = \pm 1. \quad (7.7)$$

⁹Chirality is defined only for even D , while the Majorana reality condition can be satisfied in any D , provided the spacetime signature is such that, if there are s spacelike and t timelike dimensions, then $s - t = 0, 1, 2, 6, 7 \text{ mod } 8$ [43, 44] (that is $D = 2, 3, 4, 8, 9, \text{ mod } 8$ for lorentzian signature). Thus, only in the latter case Majorana spinors can be defined unambiguously.

It can be seen that with the choice (7.4), Majorana conjugate of $\bar{\mathbf{Q}}$ is

$$\begin{aligned}\bar{\mathbf{Q}}^\gamma &= : C^{\alpha\beta} \mathbf{Q}_\beta \\ &= \begin{bmatrix} 0 & C^{\alpha\gamma} \\ -\delta_\beta^\gamma & 0 \end{bmatrix}.\end{aligned}\tag{7.8}$$

7.2 Closing the Algebra

We already encountered the bosonic generators responsible for the AdS transformations (7.1, 7.2), which has the general form required by (6.1). It is also straightforward to check that commutators of the form $[\mathbf{J}, \mathbf{Q}]$ turn out to be proportional to \mathbf{Q} , in agreement with the general form (6.2). What is by no means trivial is the closure of the anticommutator $\{\mathbf{Q}, \mathbf{Q}\}$ as in (6.3). Direct computation yields

$$\{\mathbf{Q}_\gamma, \mathbf{Q}_\lambda\}_\beta^\alpha = \begin{bmatrix} 0 & \delta_\gamma^\alpha \\ -C_{\gamma\rho} & 0 \end{bmatrix} \begin{bmatrix} 0 & \delta_\lambda^\rho \\ -C_{\lambda\beta} & 0 \end{bmatrix} + (\gamma \leftrightarrow \lambda)\tag{7.9}$$

$$= - \begin{bmatrix} \delta_\gamma^\alpha C_{\lambda\beta} + \delta_\lambda^\alpha C_{\gamma\beta} & 0 \\ 0 & C_{\gamma\lambda} + C_{\lambda\gamma} \end{bmatrix}.\tag{7.10}$$

The form of the lower diagonal piece immediately tells us that unless $C_{\gamma\lambda}$ is antisymmetric, it will be necessary to include at least one more bosonic generator (and possibly more) with nonzero entries in this diagonal block. This relation also shows that the upper diagonal block is a collection of matrices $\mathbf{M}_{\gamma\lambda}$ whose components are

$$(M_{\gamma\lambda})_\beta^\alpha = -(\delta_\gamma^\alpha C_{\lambda\beta} + \delta_\lambda^\alpha C_{\gamma\beta}).$$

Multiplying both sides of this relation by C , one finds

$$(CM_{\gamma\lambda})_{\alpha\beta} = -(C_{\alpha\gamma}C_{\lambda\beta} + C_{\alpha\lambda}C_{\gamma\beta}),\tag{7.11}$$

which is symmetric in $(\alpha\beta)$. This means that the bosonic generators can only include those matrices in the Dirac algebra such that, when multiplied by \mathbf{C} on the left ($\mathbf{C}\mathbf{I}$, $\mathbf{C}\mathbf{\Gamma}_a$, $\mathbf{C}\mathbf{\Gamma}_{a_1a_2}, \dots, \mathbf{C}\mathbf{\Gamma}_{a_1a_2\dots a_D}$) turn out to be symmetric. The other consequence of this is that, if one wants to have the AdS algebra as part of the superalgebra, both $\mathbf{C}\mathbf{\Gamma}_a$ and $\mathbf{C}\mathbf{\Gamma}_{ab}$ should be symmetric matrices. Now, multiplying (7.6) by \mathbf{C} from the right, we have

$$(\mathbf{C}\mathbf{\Gamma}_a)^T = \lambda\eta\mathbf{C}\mathbf{\Gamma}_a,\tag{7.12}$$

which means that we need

$$\lambda\eta = 1.\tag{7.13}$$

It can be seen that

$$(\mathbf{C}\mathbf{\Gamma}_{ab})^T = -\lambda\mathbf{C}\mathbf{\Gamma}_{ab},$$

which in turn requires

$$\lambda = -1 = \eta.$$

This means that \mathbf{C} is antisymmetric ($\lambda = -1$) and then the lower diagonal block in (7.10) vanishes identically. However, the values of λ and η cannot be freely chosen but are fixed by the spacetime dimension as is shown in the following table (see Ref.[50] for details)

\mathbf{D}	λ	η
3	-1	-1
5	-1	+1
7	+1	-1
9	+1	+1
11	-1	-1

and the pattern repeats mod 8. This table shows that the simple cases occur for dimensions 3 mod 8, while for the remaining cases life is a little harder. For $D = 7 \text{ mod } 8$ the need to match the lower diagonal block with some generators can be satisfied quite naturally by including several spinors labeled with a new index, $\psi_i^\alpha, i = 1, \dots, N$, and the generator of supersymmetry should also carry the same index. This means that there are actually N supercharges or, as it is usually said, the theory has an extended supersymmetry ($N \geq 2$). For $D = 5 \text{ mod } 4$ instead, the superalgebra can be made to close in spite of the fact that $\eta = +1$ if one allows complex spinor representations, which is a particular form of extended supersymmetry since now \mathbf{Q}_γ and $\bar{\mathbf{Q}}^\gamma$ are independent.

So far we have only given some restrictions necessary to close the algebra so that the AdS generators appear in the anticommutator of two supercharges. In general, however, apart from \mathbf{J}_a and \mathbf{J}_{ab} other matrices will occur in the r.h.s. of the anticommutator of \mathbf{Q} and $\bar{\mathbf{Q}}$ which extends the AdS algebra into a larger bosonic algebra. This happens even in the cases where there is no extended supersymmetry ($N = 1$). The bottom line of this construction is that the supersymmetric extension of the AdS algebra for each odd dimension falls into three different families:

- $D = 3 \text{ mod } 8$ (Majorana representation, $N \geq 1$),
- $D = 7 \text{ mod } 8$ (Majorana representation, even N), and
- $D = 5 \text{ mod } 4$ (complex representations, $N \geq 1$ [or $2N$ real spinors]).

The corresponding superalgebras¹⁰ were computed by van Holten and Van Proeyen for $D = 2, 3, 4 \text{ mod } 8$ in Ref. [54], and in the other cases, in Refs.[49, 50]:

D	S-Algebra	Conjugation Matrix
3 mod 8	$osp(m N)$	$C^T = -C$
7 mod 8	$osp(N m)$	$C^T = C$
5 mod 4	$usp(m N)$	$C^\dagger = C$

¹⁰The algebra $osp(p|q)$ (resp. $usp(p|q)$) is that which generates the orthosymplectic (resp. unitary-symplectic) Lie group. This group is defined as the one that leaves invariant the quadratic form $G_{AB}z^A z^B = g_{ab}x^a x^b + \gamma_{\alpha\beta}\theta^\alpha\theta^\beta$, where g_{ab} is a p -dimensional symmetric (resp. hermitean) matrix and $\gamma_{\alpha\beta}$ is a q -dimensional antisymmetric (resp. anti-hermitean) matrix.

8. CS Supergravity Actions

The supersymmetric extension of a given Lie algebra is a mathematical problem that has a mathematical solution, as is known from the general studies of superalgebras [57]. A particularly interesting aspect of these algebras is their representations. The previous discussion was devoted to that point, of which some cases had been studied more than 20 years ago in Ref. [54]. What is not at all trivial is how to construct a field theory action that reflects this symmetry.

We saw in the previous lecture how to construct CS actions for the AdS connection for any $D = 2n + 1$. The question is now, how to repeat this construction for the connection of a larger algebra in which AdS is embedded. The solution to this problem is well known. Consider an arbitrary connection one form \mathbb{A} , with values in some Lie algebra \mathfrak{g} , whose curvature is $\mathbb{F} = d\mathbb{A} + \mathbb{A} \wedge \mathbb{A}$. Then, the $2n$ -form

$$\mathbb{C}_{2n} \equiv \langle \mathbb{F} \wedge \cdots \wedge \mathbb{F} \rangle, \quad (8.1)$$

where $\langle \cdots \rangle$ stands for an invariant trace, is invariant under the group whose Lie algebra is \mathfrak{g} . Furthermore, \mathbb{C}_{2n} is closed: $d\mathbb{C}_{2n} = 0$, and therefore can be locally written as an exact form,

$$\mathbb{C}_{2n} = d\mathbb{L}_{2n-1}.$$

The $(2n - 1)$ -form \mathbb{L}_{2n-1} is a CS lagrangian, and therefore the problem reduces to finding the invariant trace $\langle \cdots \rangle$. The canonical –and possibly unique– choice of invariant trace with the features required here is the **supertrace**, which is defined as follows: if a matrix has the form

$$\mathbb{M} = \begin{bmatrix} J_b^a & F_\beta^a \\ H_b^\alpha & S_\beta^\alpha \end{bmatrix},$$

where a, b are (bosonic) tensor indices and α, β are (fermionic) spinor indices, then $STr[\mathbb{M}] = Tr[\mathbf{J}] - Tr[\mathbf{S}] = J_a^a - S_\alpha^\alpha$.

If we call \mathbb{G}_M the generators of the Lie algebra, so that $\mathbb{A} = G_M A^M$, $\mathbb{F} = G_M F^M$, then

$$\begin{aligned} \mathbb{C}_{2n} &= STr[\mathbb{G}_{M_1} \cdots \mathbb{G}_{M_n}] F^{M_1} \cdots F^{M_n} \\ &= g_{M_1 \cdots M_n} F^{M_1} \cdots F^{M_n} = d\mathbb{L}_{2n-1}, \end{aligned} \quad (8.2)$$

where $g_{M_1 \cdots M_n}$ is an invariant tensor of rank n in the Lie algebra. Thus, the steps to construct the CS lagrangian are straightforward: Take the supertrace of all products of generators in the superalgebra and solve equation (8.2) for \mathbb{L}_{2n-1} . Since the superalgebras are different in each dimension, the CS lagrangians differ in field content and dynamical structure from one dimension to the next, although the invariance properties are similar in all cases. The action

$$I_{2n-1}^{CS}[\mathbb{A}] = \int \mathbb{L}_{2n-1} \quad (8.3)$$

is invariant, up to surface terms, under the local gauge transformation

$$\delta\mathbb{A} = \nabla\mathbf{\Lambda}, \quad (8.4)$$

where $\mathbf{\Lambda}$ is a zero-form with values in the Lie algebra \mathfrak{g} , and ∇ is the exterior covariant derivative in the representation of \mathbb{A} . In particular, under a supersymmetry transformation, $\mathbf{\Lambda} = \bar{\epsilon}^i Q_i - \bar{Q}^i \epsilon_i$, and

$$\delta_\epsilon \mathbb{A} = \begin{bmatrix} \epsilon^k \bar{\psi}_k - \psi^k \bar{\epsilon}_k & D\epsilon_j \\ -D\bar{\epsilon}^i & \bar{\epsilon}^i \psi_j - \bar{\psi}^i \epsilon_j \end{bmatrix}, \quad (8.5)$$

where D is the covariant derivative on the bosonic connection,

$$D\epsilon_j = \left(d + \frac{1}{2}[e^a \mathbf{\Gamma}_a + \frac{1}{2}\omega^{ab} \mathbf{\Gamma}_{ab} + \frac{1}{r!} b^{[r]} \mathbf{\Gamma}_{[r]}] \right) \epsilon_j - a_j^i \epsilon_i.$$

Two interesting cases can be mentioned here:

A. D=5 SUGRA

In this case the supergroup is $U(2, 2|N)$. The associated connection can be written as

$$\mathbb{A} = e^a \mathbf{J}_a + \frac{1}{2} \omega^{ab} \mathbf{J}_{ab} + A^K \mathbf{T}_K + (\bar{\psi}^r \mathbf{Q}_r - \bar{\mathbf{Q}}^r \psi_r) + A\mathbf{Z}, \quad (8.6)$$

where the generators $\mathbf{J}_a, \mathbf{J}_{ab}$, form an AdS algebra ($so(4, 2)$), \mathbf{T}_K ($K = 1, \dots, N^2 - 1$) are the generators of $su(N)$, \mathbf{Z} generates a $U(1)$ subgroup and $\mathbf{Q}, \bar{\mathbf{Q}}$ are the supersymmetry generators, which transform in a vector representation of $SU(N)$. The Chern-Simons Lagrangian for this gauge algebra is defined by the relation $dL = iSTr[\mathbb{F}^3]$, where $\mathbb{F} = d\mathbb{A} + \mathbb{A}^2$ is the (antihermitean) curvature. Using this definition, one obtains the Lagrangian originally discussed by Chamseddine in [35],

$$L = L_G(\omega^{ab}, e^a) + L_{su(N)}(A_s^r) + L_{u(1)}(\omega^{ab}, e^a, A) + L_F(\omega^{ab}, e^a, A_s^r, A, \psi_r), \quad (8.7)$$

with

$$\begin{aligned} L_G &= \frac{1}{8} \epsilon_{abcde} [R^{ab} R^{cd} e^e / l + \frac{2}{3} R^{ab} e^c e^d e^e / l^3 + \frac{1}{5} e^a e^b e^c e^d e^e / l^5] \\ L_{su(N)} &= -Tr [\mathbf{A}(d\mathbf{A})^2 + \frac{3}{2} \mathbf{A}^3 d\mathbf{A} + \frac{3}{5} \mathbf{A}^5] \\ L_{u(1)} &= \left(\frac{1}{4^2} - \frac{1}{N^2} \right) A(dA)^2 + \frac{3}{4l^2} [T^a T_a - R^{ab} e_a e_b - l^2 R^{ab} R_{ab} / 2] A, \\ &\quad + \frac{3}{N} F_s^r F_r^s A \\ L_f &= \frac{3}{2i} [\bar{\psi}^r \mathcal{R} \nabla \psi_r + \bar{\psi}^s \mathcal{F}_s^r \nabla \psi_r] + c.c. \end{aligned} \quad (8.8)$$

where $A_s^r \equiv A^K (\mathbf{T}_K)_s^r$ is the $su(N)$ connection, F_s^r is its curvature, and the bosonic blocks of the supercurvature: $\mathcal{R} = \frac{1}{2} T^a \mathbf{\Gamma}_a + \frac{1}{4} (R^{ab} + e^a e^b) \mathbf{\Gamma}_{ab} + \frac{i}{4} d\mathbf{A} \mathbf{I} - \frac{1}{2} \psi_s \bar{\psi}^s$, $\mathcal{F}_s^r = F_s^r + \frac{i}{N} dA \delta_s^r - \frac{1}{2} \bar{\psi}^r \psi_s$. The cosmological constant is $-l^{-2}$, and the AdS covariant derivative ∇ acting on ψ_r is

$$\nabla \psi_r = D\psi_r + \frac{1}{2l} e_a^r \mathbf{\Gamma} \psi_r - A_s^r \psi_s + i \left(\frac{1}{4} - \frac{1}{N} \right) A \psi_r. \quad (8.9)$$

where D is the covariant derivative in the Lorentz connection.

The above relation implies that the fermions carry a $u(1)$ “electric” charge given by $e = (\frac{1}{4} - \frac{1}{N})$. The purely gravitational part, L_G is equal to the standard Einstein-Hilbert action with cosmological constant, plus the dimensionally continued Euler density¹¹.

The action is by construction invariant –up to a surface term– under the local (gauge generated) supersymmetry transformations $\delta_\Lambda \mathbb{A} = -(d\Lambda + [\mathbb{A}, \Lambda])$ with $\Lambda = \bar{\epsilon}^r \mathbf{Q}_r - \bar{\mathbf{Q}}^r \epsilon_r$, or

$$\begin{aligned}\delta e^a &= \frac{1}{2} (\bar{\epsilon}^r \Gamma^a \psi_r - \bar{\psi}^r \Gamma^a \epsilon_r) \\ \delta \omega^{ab} &= -\frac{1}{4} (\bar{\epsilon}^r \Gamma^{ab} \psi_r - \bar{\psi}^r \Gamma^{ab} \epsilon_r) \\ \delta A_s^r &= -i (\bar{\epsilon}^r \psi_s - \bar{\psi}^r \epsilon_s) \\ \delta \psi_r &= -\nabla \epsilon_r \\ \delta \bar{\psi}^r &= -\nabla \bar{\epsilon}^r \\ \delta A &= -i (\bar{\epsilon}^r \psi_r - \bar{\psi}^r \epsilon_r).\end{aligned}$$

As can be seen from (8.8) and (8.9), for $N = 4$ the $U(1)$ field A loses its kinetic term and decouples from the fermions (the gravitino becomes uncharged with respect to $U(1)$). The only remnant of the interaction with the A field is a dilaton-like coupling with the Pontryagin four forms for the AdS and $SU(N)$ groups (in the bosonic sector). As it is shown in Ref.[58], the case $N = 4$ is also special at the level of the algebra, which becomes the superalgebra $su(2, 2|4)$ with a $u(1)$ central extension.

In the bosonic sector, for $N = 4$, the field equation obtained from the variation with respect to A states that the Pontryagin four form of AdS and $SU(N)$ groups are proportional. Consequently, if the spatial section has no boundary, the corresponding Chern numbers must be related. Since $\Pi_4(SU(4)) = 0$, the above implies that the Pontryagin plus the Nieh-Yan number must add up to zero.

B. D=11 SUGRA

In this case, the smallest AdS superalgebra is $osp(32|1)$ and the connection is

$$\mathbb{A} = \frac{1}{2} \omega^{ab} J_{ab} + e^a J_a + \frac{1}{5!} A^{abcde} J_{abcde} + \bar{Q} \psi, \quad (8.10)$$

where A^{abcde} is a totally antisymmetric fifth-rank Lorentz tensor one-form. Now, in terms of the elementary bosonic and fermionic fields, the CS form in \mathbb{L}_{2n-1} reads

$$\mathbb{L}_{11}^{osp(32|1)}(\mathbb{A}) = L_{11}^{sp(32)}(\mathbf{\Omega}) + L_f(\mathbf{\Omega}, \psi), \quad (8.11)$$

where $\mathbf{\Omega} \equiv \frac{1}{2}(e^a \Gamma_a + \frac{1}{2} \omega^{ab} \Gamma_{ab} + \frac{1}{5!} A^{abcde} \Gamma_{abcde})$ is an $sp(32)$ connection. The bosonic part of (8.11) can be written as

$$L_{11}^{sp(32)}(\mathbf{\Omega}) = 2^{-6} L_G^{AdS}(\omega, e) - \frac{1}{2} L_T^{AdS}(\omega, e) + L_{11}^b(A, \omega, e),$$

¹¹The first term in L_G is the dimensional continuation of the Euler (or Gauss-Bonnet) density from two and four dimensions, exactly as the three-dimensional Einstein-Hilbert Lagrangian is the continuation of the two dimensional Euler density. This is the leading term in the limit of vanishing cosmological constant ($l \rightarrow \infty$), whose local supersymmetric extension yields a nontrivial extension of the Poincaré group [48].

where L_G^{AdS} is the CS form associated to the 12-dimensional Euler density, and L_T^{AdS} is the CS form whose exterior derivative is the Pontryagin form for $SO(10, 2)$ in 12 dimensions. The fermionic Lagrangian is

$$\begin{aligned} L_f = & 6(\bar{\psi}\mathcal{R}^4 D\psi) - 3[(D\bar{\psi}D\psi) + (\bar{\psi}\mathcal{R}\psi)](\bar{\psi}\mathcal{R}^2 D\psi) \\ & - 3[(\bar{\psi}\mathcal{R}^3\psi) + (D\bar{\psi}\mathcal{R}^2 D\psi)](\bar{\psi}D\psi) + \\ & 2[(D\bar{\psi}D\psi)^2 + (\bar{\psi}\mathcal{R}\psi)^2 + (\bar{\psi}\mathcal{R}\psi)(D\bar{\psi}D\psi)](\bar{\psi}D\psi), \end{aligned}$$

where $\mathcal{R} = d\Omega + \Omega^2$ is the $sp(32)$ curvature. The supersymmetry transformations (8.5) read

$$\begin{aligned} \delta e^a &= \frac{1}{8}\bar{\epsilon}\Gamma^a\psi & \delta\omega^{ab} &= -\frac{1}{8}\bar{\epsilon}\Gamma^{ab}\psi \\ \delta\psi &= D\epsilon & \delta A^{abcde} &= \frac{1}{8}\bar{\epsilon}\Gamma^{abcde}\psi. \end{aligned}$$

Standard (CJS) eleven-dimensional supergravity [55] is an $N=1$ supersymmetric extension of Einstein-Hilbert gravity that cannot admit a cosmological constant [56, 64]. An $N > 1$ extension of the CJS theory is not known. In our case, the cosmological constant is necessarily nonzero by construction and the extension simply requires including an internal $so(N)$ gauge field coupled to the fermions. The resulting Lagrangian is an $osp(32|N)$ CS form [59].

9. Summary

The supergravities presented here have two distinctive features: The fundamental field is always the connection \mathbb{A} and, in their simplest form, they are pure CS systems (matter couplings are discussed below). As a result, these theories possess a larger gravitational sector, including propagating spin connection. Contrary to what one could expect, the geometrical interpretation is quite clear, the field structure is simple and, in contrast with the standard cases, the supersymmetry transformations close off shell without auxiliary fields.

Torsion. It can be observed that the torsion Lagrangians, L_T , are odd while the torsion-free terms, L_G , are even under spacetime reflections. The minimal supersymmetric extension of the AdS group in $4k - 1$ dimensions requires using chiral spinors of $SO(4k)$ [60]. This in turn implies that the gravitational action has no definite parity and requires the combination of L_T and L_G as described above. In $D = 4k + 1$ this issue doesn't arise due to the vanishing of the torsion invariants, allowing constructing a supergravity theory based on L_G only, as in [35]. If one tries to exclude torsion terms in $4k - 1$ dimensions, one is forced to allow both chiralities for $SO(4k)$ duplicating the field content, and the resulting theory has two copies of the same system [61].

Field content and extensions with $N > 1$. The field content compares with that of the standard supergravities in $D = 5, 7, 11$ in the following table, which shows the corresponding supergravities

D	Standard supergravity	CS supergravity	Algebra
5	$e_\mu^a \psi_\mu^\alpha \bar{\psi}_{\alpha\mu}$	$e_\mu^a \omega_\mu^{ab} A_\mu A_{j\mu}^i \psi_{i\mu}^\alpha \bar{\psi}_{\alpha\mu}^i, i, j = 1, \dots, N$	$usp(2, 2 N)$
7	$e_\mu^a A_{[3]} a_{\mu j}^i \lambda^\alpha \phi \psi_\mu^{\alpha i}$	$e_\mu^a \omega_\mu^{ab} A_{\mu j}^i \psi_\mu^{\alpha i}, i, j = 1, \dots, N = 2n$	$osp(N 8)$
11	$e_\mu^a A_{[3]} \psi_\mu^\alpha$	$e_\mu^a \omega_\mu^{ab} A_\mu^{abcde} \psi_\mu^\alpha, i, j = 1, \dots, N$	$osp(32 N)$

Standard supergravity in five dimensions is dramatically different from the theory presented here, which was also discussed by Chamseddine in [35].

Standard seven-dimensional supergravity is an $N = 2$ theory (its maximal extension is $N = 4$), whose gravitational sector is given by Einstein-Hilbert gravity with cosmological constant and with a background invariant under $OSp(2|8)$ [62, 63]. Standard eleven-dimensional supergravity [55] is an $N = 1$ supersymmetric extension of Einstein-Hilbert gravity with vanishing cosmological constant. An $N > 1$ extension of this theory is not known.

In our construction, the extensions to larger N are straightforward in any dimension. In $D = 7$, the index i is allowed to run from 2 to $2s$, and the Lagrangian is a CS form for $osp(2s|8)$. In $D = 11$, one must include an internal $so(N)$ field and the Lagrangian is an $osp(32|N)$ CS form [49, 50]. The cosmological constant is necessarily nonzero in all cases.

Spectrum. The stability and positivity of the energy for the solutions of these theories is a highly nontrivial problem. As shown in Ref. [53], the number of degrees of freedom of bosonic CS systems for $D \geq 5$ is not constant throughout phase space and different regions can have radically different dynamical content. However, in a region where the rank of the symplectic form is maximal the theory may behave as a normal gauge system, and this condition would be stable under perturbations. As it is shown in [58] for $D = 5$, there exists a nontrivial extension of the AdS superalgebra with a central extension in anti-de Sitter space with only a nontrivial $U(1)$ connection but no other matter fields. In this background the symplectic form has maximal rank and the gauge superalgebra is realized in the Dirac brackets. This fact ensures a lower bound for the mass as a function of the other bosonic charges [65].

Classical solutions. The field equations for these theories, in terms of the Lorentz components $(\omega, e, A, \mathbf{A}, \psi)$, are the different Lorentz tensor components for $\langle \mathbb{F}^{n-1} \mathbb{G}_M \rangle = 0$. It is rather easy to verify that in all these theories the anti-de Sitter space is a classical solution, and that for $\psi = A = \mathbf{A} = 0$ there exist spherically symmetric, asymptotically AdS standard [37], as well as topological black holes [66]. In the extreme case these black holes can be shown to be BPS states [67].

Matter couplings. It is possible to introduce minimal couplings to matter of the form $\mathbb{A} \cdot \mathbb{J}^{ext}$. For $D = 5$, the theory couples to an electrically charged $U(1)$ 0 brane (point charge), to $SU(4)$ -colored 0 branes (quarks) or to uncharged 2-brane, whose respective worldhistories couple to A_μ , \mathbf{A}_μ^{rs} and ω_μ^{ab} respectively. For $D = 11$, the theory admits a 5-brane and a 2-brane minimally coupled to A_μ^{abcde} and ω_μ^{ab} respectively.

Standard SUGRA. Some sector of these theories might be related to the standard supergravities if one identifies the totally antisymmetric part of ω_μ^{ab} in a coordinate basis, $k_{\mu\nu\lambda}$, (sometimes called the contorsion tensor) with the abelian 3-form, $A_{[3]}$. In 11 dimensions

one could also identify the totally antisymmetrized part of A_μ^{abcde} with an abelian 6-form $A_{[6]}$, whose exterior derivative, $dA_{[6]}$, is the dual of $F_{[4]} = dA_{[3]}$. Hence, in $D = 11$ the CS theory may contain the standard supergravity as well as some kind of dual version of it.

Gravity sector. A most remarkable result from imposing the supersymmetric extension, is the fact that if one sets all fields, except those that describe the geometry $-e^a$ and ω^{ab} to zero, the remaining action has no free parameters. This means that the gravity sector is uniquely fixed. This is remarkable because as we saw already for $D = 3$ and $D = 7$, there are several CS actions that one can construct for the AdS gauge group, the Euler CS form and the so-called exotic ones, that include torsion explicitly, and the coefficients for these different CS lagrangians is not determined by the symmetry considerations. So, even from a purely gravitational point of view, if the theory admits a supersymmetric extension, it has more predictive power than if it does not.

LECTURE 4

EPILOGUE: DYNAMICAL CONTENT of CHERN SIMONS THEORIES

The physical meaning of a theory is defined by the dynamics it displays both at the classical and quantum levels. In order to understand the dynamical contents of the classical theory, the physical degrees of freedom must be identified. In particular, it should be possible –at least in principle– to separate the propagating modes from the gauge degrees of freedom, and from those which do not evolve independently at all (second class constraints). The standard way to do this is Dirac’s constrained Hamiltonian analysis and has been applied to CS systems in [53]. Here we summarize this analysis and refer the reader to the original papers for details. It is however, fair to say that a number of open problems remain and it is a area of research which is at a very different stage of development compared with the previous discussion.

10. Hamiltonian Analysis

From the dynamical point of view, a CS system can be described by a Lagrangian of the form¹²

$$L_{2n+1} = l_a^i (A_j^b) \dot{A}_i^a - A_o^a K_a, \quad (10.1)$$

where the $(2n + 1)$ -dimensional spacetime has been split into space and time, and

$$K_a = -\frac{1}{2^n n!} \gamma_{aa_1 \dots a_n} \epsilon^{i_1 \dots i_{2n}} F_{i_1 i_2}^{a_1} \dots F_{i_{2n-1} i_{2n}}^{a_n}.$$

The field equations are

$$\Omega_{ab}^{ij} (\dot{A}_j^b - D_j A_0^b) = 0, \quad (10.2)$$

$$K_a = 0, \quad (10.3)$$

¹²Note that in this section, for notational simplicity, we assume the spacetime to be $(2n + 1)$ -dimensional.

where

$$\begin{aligned}\Omega_{ab}^{ij} &= \frac{\delta l_b^j}{\delta A_i^a} - \frac{\delta l_a^i}{\delta A_j^b} \\ &= -\frac{1}{2^{n-1}} \gamma_{aba_2 \dots a_n} \epsilon^{ij i_3 \dots i_{2n}} F_{i_3 i_4}^{a_2} \dots F_{i_{2n-1} i_{2n}}^{a_n}\end{aligned}\tag{10.4}$$

is the **symplectic form**. The passage to the Hamiltonian has the problem that the velocities appear linearly in the Lagrangian and therefore there are a number of primary constraints

$$\phi_a^i \equiv p_a^i - l_a^i \approx 0.\tag{10.5}$$

Besides these, there are secondary constraints $K_a \approx 0$, which can be combined with the ϕ s into the expressions

$$G_a \equiv -K_a + D_i \phi_a^i.\tag{10.6}$$

The complete set of constraints forms a closed Poisson bracket algebra,

$$\begin{aligned}\{\phi_a^i, \phi_b^j\} &= \Omega_{ab}^{ij} \\ \{\phi_a^i, G_b\} &= f_{ab}^c \phi_c^i, \\ \{G_a, G_b\} &= f_{ab}^c G_c\end{aligned}$$

where f_{ab}^c are the structure constants of the gauge algebra of the theory. Clearly the G s form a first class algebra which reflects the gauge invariance of the theory, while some of the ϕ s are second class and some are first class, depending on the rank of the symplectic form Ω .

10.1 Degeneracy

An intriguing aspect of Chern-Simons theories is the multiplicity of ground states that they can have. This can be seen from the field equations, which for $D = 2n + 1$, are polynomials of degree n which in general have a very rich root structure. As the symplectic form is field-dependent, the rank of the matrix Ω_{ab}^{ij} need not be constant. It can change from one region of phase space to another, with different degrees of degeneracy. Regions in phase space with different degrees of degeneracy define dynamically distinct and independent effective theories [68]. If the system reaches a degenerate configuration, some degrees of freedom are frozen in an irreversible process which erases all traces of the initial conditions of the lost degrees of freedom. One can speculate about the potential of this phenomenon as a way to produce dimensional reduction through a dynamical process.

This issue was analyzed in the context of some simplified mechanical models and the conclusion was that the degeneracy of the system occurs at submanifolds of lower dimensionality in phase space, which are sets of unstable initial states or sets of stable end points for the evolution [68]. Unless the system is chaotic, it can be expected that **generic configurations**, where the rank of Ω_{ab}^{ij} is maximal, fill most of phase space. As it was shown in Ref. [68], if the system evolves along an orbit that reaches a surface of degeneracy, Σ , it becomes trapped by the surface and loses the degrees of freedom that correspond to displacements away from

Σ . This is an irreversible process which can be viewed as mechanism for dynamical reduction of degrees of freedom or dimensional reduction. A process of this type is seen to take place in the dynamics of vortices in a fluid, where two vortices coalesce and annihilate each other in an irreversible process.

10.2 Generic counting

There is a second problem and that is how to separate the first and second class constraints among the ϕ s. In Ref.[53] the following results are shown:

- The maximal rank of Ω_{ab}^{ij} is $2nN - 2n$, where N is the number of generators in the gauge Lie algebra.
- There are $2n$ first class constraints among the ϕ s which correspond to the generators of spatial diffeomorphisms (\mathcal{H}_i).
- The generator of timelike reparametrizations \mathcal{H}_\perp is not an independent first class constraint.

Putting all these facts together one concludes that, in a generic configuration, the number of degrees of freedom of the theory (ζ^{CS}) is

$$\begin{aligned} \zeta^{CS} &= (\text{number of coordinates}) - (\text{number of 1st class constraints}) \\ &\quad - \frac{1}{2}(\text{number of 2nd class constraints}) \\ &= 2nN - (N + 2n) - \frac{1}{2}(2nN - 2n) \end{aligned} \tag{10.7}$$

$$= nN - N - n. \tag{10.8}$$

This result is somewhat perplexing. A standard (metric) Lovelock theory of gravity in $D = 2n + 1$ dimensions, has

$$\begin{aligned} \zeta^{Lovelock} &= D(D - 3)/2 \\ &= (2n + 1)(n - 1) \end{aligned}$$

propagating degrees of freedom [28]. A CS gravity system for the AdS group in the same dimension gives a much larger number,

$$\zeta^{CS} = 2n^3 + n^2 - 3n - 1. \tag{10.9}$$

In particular, for $D = 5$, $\zeta^{CS} = 13$, while $\zeta^{Lovelock} = 5$. The extra degrees of freedom correspond to propagating modes in ω^{ab} , which in the CS theory are independent from the metric ones contained in e^a .

As it is also shown in [53], an important simplification occurs when the group has an invariant abelian factor. In that case the symplectic matrix Ω_{ab}^{ij} takes a partially block-diagonal form where the kernel has the maximal size allowed by a generic configuration. It

is a nice surprise in the cases of CS supergravities discussed above that for certain unique choices of N , the algebras develop an abelian subalgebra and make the separation of first and second class constraints possible (e.g., $N = 4$ for $D = 5$, and $N = 32$ for $d = 11$). In some cases the algebra is not a direct sum but an algebra with an abelian central extension ($D = 5$). In other cases, the algebra is a direct sum, but the abelian subgroup is not put in by hand but it is a subset of the generators that decouple from the rest of the algebra ($D = 11$).

10.3 Regularity conditions

The counting discussed in [53] was found to fail in the particular example of CS supergravity in 5 dimensions. This is due to a different kind of difficulty: the fact that the symmetry generators (first class constraints) can fail to be functionally independent at some points of phase space. This is a second type of degeneracy and makes it impossible to approximate the theory by a linearized one. In fact, it can be seen that the number of degrees of freedom of the linearized theory is larger than in the original one [58]. This is the subject of an ongoing investigation which will be reported elsewhere [69].

11. Final Comments

1. Everything we know about the gravitational interaction at the classical level, is described by Einstein's theory in four dimensions, which in turn is supported by a handful of experimental observations. There are many indications, however, that make it plausible to accept that our spacetime has more dimensions than those that meet the eye. In a spacetime of more than four dimensions, it is not logically necessary to consider the Einstein-Hilbert action as the best description for gravity. In fact, string theory suggests a Lanczos-Lovelock type action as more natural [27]. The large number of free parameters in the LL action, however, cannot be fixed by arguments from string theory. As we have shown, the only case in which there is a simple symmetry principle to fix these coefficients is odd dimensions and that leads to the Chern-Simons theories.

2. The CS theories of gravity have a profound geometrical meaning that relates them to topological invariants –the Euler and the Chern or Pontryagin classes– and come about in a very natural way in a framework where the affine and metric structures of the geometry are taken to be independent dynamical objects. If one demands furthermore the theory to admit supersymmetry, there is, in each dimensions essentially a unique extension which completely fixes the gravitational sector, including the precise role of torsion in the action.

3. The CS theories of gravity obtained are classically and semiclassically interesting. They possess nontrivial black hole solutions [40] which asymptotically approach spacetimes of constant negative curvature (AdS spacetimes). These solutions have a thermodynamical behavior which is unique among all possible black holes in competing LL theories with the same asymptotics [70]. These black holes have positive and can therefore always reach thermal equilibrium with their surroundings. These theories also admit solutions which represent black objects, in the sense that they possess a horizon that hides a singularity, but the horizon topology is

not spherical but a surface of constant nonpositive Ricci curvature [72]. Furthermore, these solutions seem to have a well defined, quantum mechanically stable ground states [67] which have been shown to be BPS states of diverse topologies.

4. We have no way of telling at present what will be the fate of string theory as a description of all interactions and constituents of nature. If it is the right scenario and gravity is just a low energy effective theory that would be a compelling reason to study gravity in higher dimensions, not as an academic exercise as could have seemed in the time of Lanczos, but as a tool to study big bang cosmology or black hole physics for instance. The truth is that a field theory can tell us a lot about the low energy phenomenology, in the same way that ordinary quantum mechanics tells us a lot about atomic physics even if we know that is all somehow contained in QED.

5. Chern-Simons theories contain a wealth of other interesting features, starting with their relation to geometry, gauge theories and knot invariants. The higher-dimensional CS systems remain somewhat mysterious especially because of the difficulties to treat them as quantum theories. However, they have many ingredients that make CS theories likely models to be quantized: They carry no dimensionful couplings, the only parameters they have are quantized, they are the only ones in the Lovelock family of gravity theories that give rise to black holes with positive specific heat [70] and hence, capable of reaching thermal equilibrium with an external heat bath. Efforts to quantize CS systems seem promising at least in the cases in which the space admits a complex structure so that the symplectic form can be cast as a Kähler form [71]. However, there is a number of open questions that one needs to address before CS theories can be applied to describe the microscopic world, like their Yang-Mills relatives. Until then, they are beautiful mathematical models and interesting physical systems worth studying.

6. If the string scenario fails to deliver its promise, more work will still be needed to understand the field theories it is supposed to represent, in order to decipher their deeper interrelations. In this case, geometry is likely to be an important clue, very much in the same way that it is an essential element in Yang Mills and Einstein's theory. One can see the construction discussed in these lectures as a walking tour in this direction.

It is perhaps appropriate to end these lectures quoting E. Wigner in full [1]:

"The miracle of appropriateness of the language of mathematics for the formulation of the laws of physics is a wonderful gift which we neither understand nor deserve. We should be grateful for it, and hope that it will remain valid for future research, and that it will extend, for better or for worse, to our pleasure even though perhaps also to our bafflement, to wide branches of learning".

Acknowledgments

It is a pleasure for me to thank the organizers and the staff of the school for the stimulating discussions and friendly atmosphere in the charming colonial city of Villa de Leyva. I am

especially thankful for the efforts of M. Kovacsics to make sure that a vegetarian would not only survive but be treated with best fruits of the land. I wish to thank R. Aros, J. Bellissard, C. Martínez, S. Theisen, C. Teitelboim and R. Troncoso for many enlightening discussions and helpful comments, and F. Mansouri for pointing out to me a number of interesting references. I am especially grateful to Sylvie Paycha for carefully proof reading and correcting many mistakes in the original manuscript, both in style and in mathematics. I wish also thank the Albert Einstein Institute for Gravitational Physics of the Max Planck Institute at Potsdam for the hospitality, encouragement and resources to write up these notes. This work was supported in part by FONDECYT grants 1990189, 1010450, 1020629 and by the generous institutional support to CECS from Empresas CMPC. CECS is a Millennium Science Institute.

References

- [1] E. Wigner, *The Unreasonable Effectiveness of Mathematics*, Comm. Pure and App. Math. **13** (1960) 1-14.
- [2] S. Schweber, *QCD and the Men who Made it: Dyson, Feynman, Schwinger and Tomonaga*, Princeton University Press, Princeton (1994).
- [3] G. 't Hooft and M. J. G. Veltman, *Regularization and Renormalization of Gauge Fields*, Nucl.Phys.**B44** (1972) 189-213.
- [4] S. Weinberg, in *Nobel Lectures in Physics 1971-1980*, S. Lundqvist, ed. World Scientific, Singapore (1992).
- [5] Sylvie Paycha, Lecture notes for this school.
- [6] M. Nakahara, *Geometry, Topology and Physics* Adam Hilger, New York, (1990). T. Eguchi, P. B. Gilkey, and A. J. Hanson, *Gravitation, Gauge Theories and Differential Geometry* Phys. Rept. **66** (1980) 213-393.
- [7] C. N. Yang and R. Mills, *Conservation of Isotopic Spin and Isotopic Gauge Invariance* Phys. Rev. **96** (1954) 191-195.
- [8] Symmetries described by open algebras require a different treatment from the standard one for gauge theories, see, e. g., M. Henneaux, *Hamiltonian Form of the Path Integral for Theories with a Gauge Freedom* Phys. Rept.**126** (1985) 1-66.
- [9] A. Einstein, *Die Feldgleichungen der Gravitation*, Preuss. Akad. Wiss. Berlin, Sitzber. **47** (1915) 844-847.
- [10] D. Hilbert, *Die Grundlagen der Physik* Konigl. Gesell. d. Wiss. Göttingen, Nachr., Math.-Phys. Kl., (1915) 395-407.
- [11] C. W. Misner, K. S. Thorne and J. A. Wheeler, *Gravitation*, W. H. Freeman, New York (1973).
- [12] S. Weinberg, *The Cosmological Constant Problem*, Rev. Mod. Phys. **61** (1989) 1-23.
- [13] J. Glanz, *Exploding Stars Point to a Universal Repulsive Force*, Science **279**, (1998) 651. V. Sahni and A. Starobinsky, *The Case for a Positive Cosmological Lambda Term*, Int. J. Mod. Phys. **D9** (2000) 373-444.

- [14] W. Dunham, *Journey Through Genius: The Great Theorems of Mathematics*, Penguin Books, New York (1991).
- [15] R. Debever, *Elie Cartan - Albert Einstein Lettres sur le Parallélisme Absolu, 1929-1932*, Académie Royale de Belgique, Princeton University Press. Princeton (1979).
- [16] B. F. Schutz, *A First Course in General Relativity*, Cambridge University Press (1985).
- [17] M. Goeckeler and T. Schuecker, *Differential Geometry, Gauge Theories and Gravity*, Cambridge University Press (1987).
- [18] R. Utiyama, *Invariant Theoretical Interpretation of Interaction*, Phys. Rev. **101**, (1955) 1597-1607.
- [19] T. W. B. Kibble, *Lorentz Invariance and the Gravitational Field* J. Math. Phys. **2**, (1961) 212-221.
- [20] C. N. Yang, *Integral Formalism for Gauge Fields* Phys. Rev. Lett. **33**, (1974) 445-447.
- [21] F. Mansouri, *Gravitation as a Gauge Theory*, Phys. Rev. **D13** (1976) 3192-3200.
- [22] S. W. MacDowell and F. Mansouri, *Unified Geometric Theory of Gravity and Supergravity* Phys. Rev. Lett. **38**, (1977) 739-742.
- [23] B. Zumino, *Gravity Theories in More than Four Dimensions*, Phys. Rep. **137** (1986) 109-114.
- [24] T. Regge, *On Broken Symmetries and Gravity*, Phys. Rep. **137** (1986) 31-33.
- [25] D. Lovelock, *the Einstein Tensor and its Generalizations*, J. Math. Phys. **12** (1971) 498-501.
- [26] C. Lanczos, *A Remarkable Property of the Riemann-Christoffel Tensor in Four Dimensions*, Ann. Math. **39** (1938) 842-850.
- [27] B. Zwiebach, *Curvature Squared Terms and String Theories*, Phys. Lett. **B156** (1985) 315-317.
- [28] C. Teitelboim and J. Zanelli, *Dimensionally Continued Topological Gravitation Theory in Hamiltonian Form*, Class. and Quantum Grav. **4**(1987) L125-129; and in *Constraint Theory and Relativistic Dynamics*, edited by G. Longhi and L. Lussana, World Scientific, Singapore (1987).
- [29] A. Mardones and J. Zanelli, *Lovelock-Cartan Theory of Gravity*, Class. and Quantum Grav. **8**(1991) 1545-1558.
- [30] H. T. Nieh and M. L. Yan, *An Identity in Riemann-Cartan Geometry*, J. Math. Phys. **23** (1982) 373.
- [31] O. Chandía and J. Zanelli, *Topological Invariants, Instantons and Chiral Anomaly on Spaces with Torsion*, Phys. Rev. **D55** (1997) 7580-7585; *Supersymmetric Particle in a Spacetime with Torsion and the Index Theorem*, **D58** (1998) 045014/1-4.
- [32] G.'t Hooft and M. Veltman, *One Loop Divergencies in the Theory of Gravitation*, Ann. Inst. H. Poincaré (Phys. Theor.) **A20** (1974) 69-94.
- [33] A. Achúcarro and P. K. Townsend, *A Chern-Simons Action for Three-Dimensional Anti-de Sitter Supergravity Theories*, Phys. Lett. **B180** (1986) 89.
- [34] E. Witten, *(2+1)-Dimensional Gravity as an Exactly Soluble System*, Nucl. Phys. **B311** (1988) 46-78.

- [35] A. Chamseddine, *Topological Gauge Theory of Gravity in Five Dimensions and all odd Dimensions*, Phys. Lett. **B233** (1989) 291-294; *Topological Gravity and Supergravity in Various Dimensions*, Nucl. Phys. **B346** (1990) 213-234.
- [36] F. Müller-Hoissen, *From Chern-Simons to Gauss-Bonnet*, Nucl. Phys. **B346** (1990) 235-252.
- [37] M. Bañados, C. Teitelboim and J. Zanelli, *Lovelock-Born-Infeld Theory of Gravity*, in J. J. Giambiagi Festschrift, La Plata, May 1990, edited by H. Falomir, R. RE. Gamboa, P. Leal and F. Schaposnik, World Scientific, Singapore (1991).
- [38] J. Zanelli, *Quantization of the Gravitational Constant in odd Dimensions*, Phys. Rev. **D51** (1995) 490-492.
- [39] R. Jackiw, *Diverse Topics in Theoretical and Mathematical Physics*, World Scientific, Singapore (1995).
- [40] M. Bañados, C. Teitelboim and J. Zanelli, *Dimensionally Continued Black Holes*, Phys. Rev. **D49** (1994) 975-986.
- [41] R. Troncoso and J. Zanelli, *Higher-Dimensional Gravity, Propagating Torsion and AdS Gauge Invariance*, Class. and Quantum Grav. **17** (2000) 4451-4466.
- [42] S. Theisen, Lecture notes for this school.
- [43] M. Sohnius, *Introducing Supersymmetry*, Phys. Rept. **28** (1985) 39-204.
- [44] P. G. O. Freund, *Introduction to Supersymmetry*, Cambridge University Press (1988).
- [45] P. van Nieuwenhuizen, *Supergravity*, Phys. Rep. **68** (1981) 189-398.
- [46] P. K. Townsend, *Three Lectures on Quantum Supersymmetry and Supergravity*, Supersymmetry and Supergravity '84, Trieste Spring School, April 1984, B. de Wit, P. Fayet, and P. van Nieuwenhuizen, editors, World Scientific, Singapore (1984).
- [47] V. O. Rivelles and C. Taylor, *Off-Shell Extended Supergravity and Central Charges*, Phys. Lett. **B104** (1981) 131-135; *Off-Shell No-Go Theorems for Higher Dimensional Supersymmetries and Supergravities*, Phys. Lett. **B121** (1983) 37-42.
- [48] M. Bañados, R. Troncoso and J. Zanelli, *Higher Dimensional Chern-Simons Supergravity*, Phys. Rev. **D54** (1996) 2605-2611.
- [49] R. Troncoso and J. Zanelli, *New Gauge Supergravity in Seven and Eleven Dimensions*, Phys. Rev. **D58** (1998) R101703/1-5.
- [50] R. Troncoso and J. Zanelli, *Gauge Supergravities for all Odd Dimensions*, Int. Jour. Theor. Phys. **38** (1999) 1181-1206.
- [51] A. Losev, M. A. Shifman, A. I. Vainshtein, *Counting Supershort Multiplets*, Phys. Lett. **B522** (2001) 327-334.
- [52] C. Fronsdal, *Elementary particles in a curved space. II*, Phys. Rev. **D10** (1973) 589-598.
- [53] M. Bañados, L. J. Garay and M. Henneaux, *Existence of Local Degrees of Freedom for Higher Dimensional Pure Chern-Simons Theories*, Phys. Rev. **D53** (1996) R593-596; *The Dynamical Structure of Higher Dimensional Chern-Simons Theory*, Nucl. Phys. **B476** (1996) 611-635.

- [54] J.W. van Holten and A. Van Proeyen, *N=1 Supersymmetry Algebras in D=2, D=3, D=4 mod-8*, J. Phys. **A15** (1982) 3763-3779.
- [55] E. Cremmer, B. Julia, and J. Scherk, *Supergravity Theory in Eleven Dimensions*, Phys. Lett. **B76** (1978) 409-412.
- [56] K.Bautier, S.Deser, M.Henneaux and D.Seminara, *No cosmological D=11 Supergravity*, Phys.Lett. **B406** (1997) 49-53.
- [57] V. G. Kac, *A Sketch of Lie Superalgebra Theory*, Comm. Math. Phys. **53**(1977) 31-64.
- [58] O. Chandía, R. Troncoso and J. Zanelli, *Dynamical Content of Chern-Simons Supergravity*, Second La Plata Meeting on Trends in Theoretical Physics, Buenos Aires, (1998), H. Falomir, R.E.Gamboa Saraví and F.A.Schaposnik, editors, American Institute of Physics (1999) hep-th/9903204.
- [59] R. Troncoso, *Supergravidad en Dimensiones Impares*, Doctoral Thesis, University of Chile, Santiago (1996).
- [60] M. Günaydin and C. Saclioglu, *Oscillator-like Unitary Representations of Noncompact Groups with a Jordan Structure and the Noncompact Groups of Supergravity*, Comm. Math. Phys. **87** (1982) 159-174.
- [61] P. Horava, *M Theory as a Holographic Field Theory*, Phys. Rev. **D59** (1999) 046004.
- [62] P. K. Townsend and P. van Nieuwenhuizen, *Gauged Seven-Dimensional Supergravity*, Phys. Lett. **125B**(1983) 41-45.
- [63] A. Salam and E. Sezgin, *SO(4) Gauging of N=2 Supergravity in Seven Dimensions*, Phys. Lett. **126B** (1983) 295-300.
- [64] S. Deser, *Uniqueness of D = 11 Supergravity*, in Black Holes and the Structure of the Universe, C. Teitelboim and J. Zanelli, editors, World Scientific, Singapore (2000), hep-th/9712064.
- [65] G. W. Gibbons and C. M. Hull, *A Bogomolny Bound for General Relativity and Solitons in N=2 Supergravity*, Phys. Lett. **B109** (1982) 190-196.
- [66] S. Aminneborg, I. Bengtsson, S. Holst and P. Peldan, *Making anti-de Sitter Black Holes*, Class. Quantum Grav.**13** (1996) 2707-2714. M. Bañados, *Constant Curvature Black Holes*, Phys. Rev. **D57** (1998), 1068-1072. R.B. Mann, *Topological Black Holes: Outside Looking In*, e-print gr-qc/9709039.
- [67] R. Aros, C. Martínez, R. Troncoso and J. Zanelli, *Supersymmetry of Gravitational Ground States*, Jour. High Energy Phys. JHEP **05** (2002) 020-035.
- [68] J. Saavedra, R. Troncoso and J. Zanelli, *Degenerate Dynamical Systems*, J. Math. Phys **42**(2001) 4383-4390.
- [69] O. Misković and J. Zanelli, (manuscript in preparation).
- [70] J. Crisóstomo, R. Troncoso and J. Zanelli, *Black Hole Scan*, Phys. Rev. **D62** (2000) 084013/1-14.
- [71] V. P. Nair and J. Schiff, *A Kähler-Chern-Simons Theory and Quantization of Instanton Moduli Space*, Phys. Lett. **B246** (1990) 423-429; *Kähler-Chern-Simons Theory and Symmetries of anti-self-dual Gauge Fields*, Nucl. Phys. **B371**, (1992) 329-352.

- [72] R. Aros, R. Troncoso and J. Zanelli, *Black Holes with Topologically Nontrivial Asymptotics*, Phys. Rev. **D63** (2001) 0845015/1-12.