

Buffer is All You Need: Defending Federated Learning against Backdoor Attacks under Non-iids via Buffering

Xingyu Lyu*, Ning Wang[†], Yang Xiao[‡], Shixiong Li*, Tao Li[§], Danjue Chen[¶], Yimin Chen*

* Miner School of Computer and Information Sciences, University of Massachusetts Lowell, USA,

[†] Department of Computer Science and Engineering, University of South Florida, USA,

[‡] Department of Computer Science, University of Kentucky,

[§] Department of Computer and Information Technology, Purdue University, USA,

[¶] Department of Civil, Construction, and Environmental Engineering, North Carolina State University, USA

*{xingyu_lyu, shixiong_li, ian_chen}@uml.edu, [†] ningw@usf.edu, [‡] litao@purdue.edu, [§] dchen33@ncsu.edu

Abstract—Federated Learning (FL) is a popular paradigm enabling clients to jointly train a global model without sharing raw data. However, FL is known to be vulnerable towards backdoor attacks due to its distributed nature. As participants, attackers can upload model updates that effectively compromise FL. What’s worse, existing defenses are mostly *designed* under independent-and-identically-distributed (iid) settings, hence neglecting the fundamental non-iid characteristic of FL. Here we propose *FLBuff* for tackling backdoor attacks even under non-iids. The main challenge for such defenses is that *non-iids bring benign and malicious updates closer, hence harder to separate*. *FLBuff* is inspired by our insight that non-iids can be modeled as omni-directional expansion in representation space while backdoor attacks as uni-directional. This leads to the key design of *FLBuff*, i.e., a supervised-contrastive-learning model extracting penultimate-layer representations to create a large in-between buffer layer. Comprehensive evaluations demonstrate that *FLBuff* consistently outperforms state-of-the-art defenses.

Index Terms—Federated Learning (FL), backdoor attacks, defenses, non-iid

I. INTRODUCTION

While Federated Learning (FL) has been widely recognized as one major framework for training machine learning (ML) models distributively, one main hurdle is its vulnerability towards poisoning attacks. The key aim of poisoning attacks is to either degrade the overall performance (i.e., untargeted attacks [1]) or manipulate the output predictions (i.e., targeted or backdoor attacks [2]) of the victim model. Among them, backdoor attacks on FL such as *Scaling* [3] and *ALIE* [4] can use a simple inserted backdoor to trigger the victim model to output desired labels stealthily and effectively. Therefore, it is very critical to develop defense solutions for FL against them.

In recent years, researchers have proposed defenses [5]–[11] that are shown to be effective. However, most of them are *designed* under the assumption of independent-and-identically-distributed (iid) settings, neglecting the fundamental non-iid characteristic of FL. That is, the data distributions at different clients are inevitably different in practice, i.e., non-iid. Some defenses provide their non-iid evaluations however only under

Defense	non-iid categories evaluated
FLTrust [5], FLDetector [7], FLAME [12], FreqFed [11]	prob
FLIP [8]	dir
FLARE [6]	qty
MESAS [10]	dir, qty
CrowdGuard [9]	prob, dir
FLBuff	prob, dir, qty, noise, qs

TABLE I: A brief comparison between *FLBuff* and recent defenses with respect to non-iid categories evaluated.

one or two types as illustrated in Table I, which limits their applicability in real-world scenarios.

Instead, we aim to propose a *lightweight* and *widely applicable* defense for FL against backdoor attacks, which works under a broad range of backdoors and non-iid scenarios. Essentially, we aim to bridge the above gap by taking a principled approach through answering three research questions.

RQ1: What is the current landscape when it comes to defenses against backdoor attacks in FL under comprehensive non-iid settings? Our goal is to obtain key insights for why prior defenses would not work under various non-iids as well as provide a friendly benchmark framework for researchers to evaluate backdoor attacks and defenses under comprehensive non-iid settings. **RQ2:** Can we model the impacts of various non-iids and various backdoor attacks *under the same perspective* so that by design, non-iids would not compromise our defense against backdoor attacks? Our investigations show that non-iids had significantly harmed prior defenses as benign model updates under non-iids became much less distinguishable from malicious ones (see Fig. 4). We aim to identify a representation space where the impacts of non-iids and backdoor attacks are differentiable. Following that, our third question emerges as **RQ3:** What is the key design under different non-iids so that the resulted solution is expected to work by design?

Contributions. We accomplish the following achievements in this paper. In answering **RQ1**, we develop an evaluation framework consisting of popular backdoor attacks and defenses under comprehensive non-iid settings including *label-based, quantity-based, and feature-based non-iids*. The framework can be conveniently used by researchers to evaluate SOTA defenses on comprehensive attack profiles. In answering **RQ2**, we identify that from the perspective of representation space, non-iids and backdoor attacks are fundamentally different and therefore potentially differentiable. On the one hand, the impact of non-iids can be modeled as omnidirectional and small expansion of the cluster of benign model updates under iid. On the other hand, the impact of backdoor attacks resembles a large directional displacement from the same benign cluster, illustrated in Fig. 3a. Prior defenses do not work well as *the expansion from non-iids become overlapped with the cluster of backdoor model updates*. Hence our core design goal is *to create a sufficiently large buffer layer* that can cover non-iid expansion and leave room between benign and backdoor clusters (see Fig. 3b.) Finally, we propose our solution for defending Federated Learning against generic backdoor attacks under Non-IIDs via **Buffering**, i.e., **FLBuff**, featuring creating a viable in-between buffer layer by using a supervised-contrastive-learning-based (Sup-CL-based) loss, i.e., addressing **RQ3**. Particularly, FLBuff is shown to tackle a range of backdoor attacks under non-iids and even unknown ones by training from a labeled dataset under iid consisting of malicious model updates from only one backdoor attack and benign ones. We further summarize our contributions as follows.

- We propose FLBuff, an effective supervised-learning-based defense against generic backdoor attacks under comprehensive non-iids. To the best of our knowledge, FLBuff is the first backdoor defense focusing on addressing non-iids in a systematic and comprehensive way.
- We identify the fundamental differences between backdoor attacks and non-iids based on an established unified view in representation space.
- We evaluate the performance of FLBuff through comprehensive experiments that encompass popular backdoor attacks and defenses across four datasets. Compared to five baselines, FLBuff consistently outperforms them. Furthermore, our results also show that FLBuff can be applied to unseen backdoor attacks and is resilient towards various factors including strong adaptive attacks even under non-iids, hence confirming its practicality.

II. SYSTEM AND ADVERSARY MODEL

A. System Model

Our FL system consists of two main entities: a parameter server (PS) and n remote clients (denoted as $[n] := \{1, 2, \dots, n\}$). As discussed in Sect. I, we focus specifically on non-iid settings, where the local dataset \mathcal{D}_i of a remote

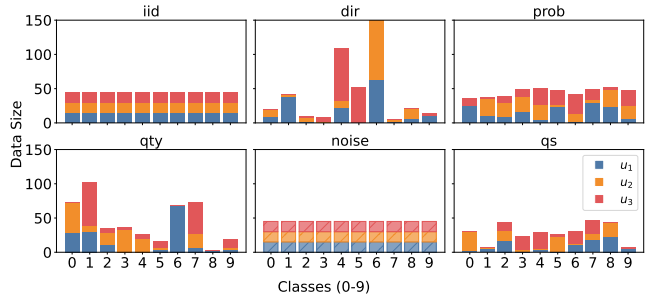

Fig. 1: Illustrations of iid and five non-iids (dir-based, prob-based, qty-based, noise, qs) for u_1, u_2 , and u_3 , and 10 label classes.

client u_i follows certain non-identical distributions, i.e., non-iids. Fig. 1 provides illustrations of iid and the five non-iids we focus on in this paper, assuming a simple scenario with three clients (u_1, u_2 , and u_3), 10 data classes (from label ‘0’ to label ‘9’), and 150 samples per client. Here we only introduce them briefly while retaining the details in **supplementary**. First, iid refers to the case where different clients have the same number of data classes and the same number of samples per class. Second, we define the five investigated non-iid types briefly as below.

- **Type-I non-iid (dir)**: Dirichlet distribution-based label imbalance, i.e., dir-based, where we allocate each client (u_1, u_2 , and u_3) a certain number of samples per label (can even be 0) according to a given Dirichlet distribution. Existing defenses in [8]–[10] have explored this non-iid.
- **Type-II non-iid (prob)**: Probability-based label imbalance, i.e., prob-based, where clients (u_1, u_2 , and u_3) are first divided into G groups based on the main label class(es) they have (‘0’, ‘1’, and ‘6’ for u_1, u_2 , and u_3 , respectively) and then a given data sample is assigned to its primary group with probability q and to other groups with probability $\frac{1-q}{G-1}$ as in [1], [5], [7], [9].
- **Type-III non-iid (qty)**: Quantity-based label imbalance, i.e., qty-based, where each client only has training samples from the same number of labels [6], [13].
- **Type-IV non-iid (noise)**: Noise-based feature distribution skew where we add Gaussian noise to the samples of each client u_i to achieve feature diversity [14] after dividing the dataset equally among u_1, u_2 , and u_3 .
- **Type-V non-iid (quantity-skew, qs)**: quantity skew where we use a Dirichlet distribution to allocate different number of samples to each client as in [14], [15].

In brief, we find that rarely an existing defense against backdoor attacks had considered more than two non-iids while FLBuff is the first to tackle five most frequent ones.

B. Adversary Model

Attackers’ goals. We adopt the attack goals from recent backdoor attacks [3], [4], [16]. On the one hand, a backdoor attacker aims to insert their backdoors into the global model Θ so that Θ is misled to classify specific input samples into the attacker’s target label. On the other hand, Θ under attack needs

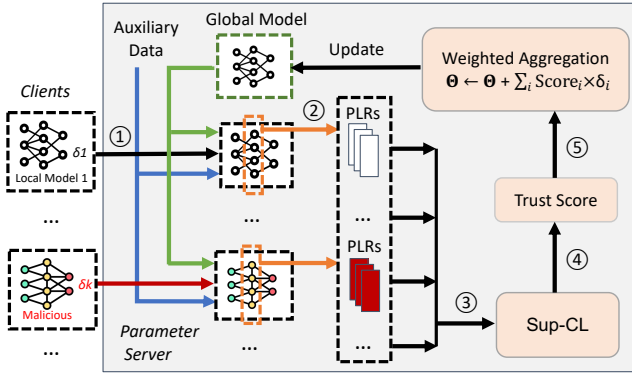

Fig. 2: Workflow of FL with FLBuff.

to maintain a relatively high model accuracy on ‘clean’ inputs so that the attack remains difficult to notice (i.e., stealthy).

Attackers’ capabilities. Similar to [3], [4], [16], we assume that our backdoor attackers have access to a dataset that they can use to train their local models. Furthermore, they can arbitrarily manipulate (modify, add, or delete) their data, which can involve inserting triggers into samples and altering labels. They can manipulate their model updates as they want to achieve the above goals. We also assume backdoor attackers are treated as legitimate clients and therefore they have white-box access to Θ but no local models of other clients. We assume the number of malicious clients to be less than half of all clients. PS is trusted and to deploy FLBuff to properly protect Θ .

III. DESIGN OF FLBUFF

A. Intuition

Our intuition for FLBuff is based on our unique perspective for non-iids and backdoor attacks, illustrated in Fig. 3. We can see that in representation space, the green solid circle, the blue dotted circle, and the red solid circle denote the cluster of iid benign model updates, that of non-iid benign model updates, and finally that of malicious model updates, respectively. On the one hand, we model *the impacts of different non-iids as different expansions from the green circle to the blue one* under different sets of angles and displacements, uniquely determined by each individual non-iid. On the other hand, we model *the impacts of one backdoor attack as a uni-directional displacement from the green circle to the red one*. What’s more, defense performance degradation comes from that the blue circle starts to overlap with the red circle as a result of expansion (see Fig. 3a). Therefore, FLBuff focuses on creating a sufficiently large buffer layer between the expanded blue circle and the red circle so that FLBuff can work under different non-iids (see Fig. 3b). FLBuff is expected to work on different backdoor attacks as well because a larger buffer keeps all red circles (i.e., various backdoor attacks) out of the zone of the blue circle (see Fig. 3c).

B. FLBuff: Buffer is All You Need

Based on the above intuition, the core design of FLBuff is to create a sufficiently large buffer layer in the representation space between the cluster of benign updates under non-iids and that of malicious updates. To that end, we design FLBuff as an aggregation-based defense which uses penultimate layer representations (PLRs) to denote model updates from remote clients and a supervised contrastive learning model to further train better representations from labeled PLRs. Fig. 2 shows the workflow of FLBuff as explained below.

Step 1: A selected client u_i needs to send her model update δ_i after local training to PS.

Step 2: FLBuff is to compute the PLR sequence for each received δ_i . Following the SOTA defenses [5], [6], [9], we assume that PS has a small set of auxiliary data (denoted by D_A) for computing PLR sequences. We show later in Sect. IV-B3 that D_A can be samples from public generic dataset as well. Given δ_i , FLBuff first aggregates Θ and δ_i together and obtains Θ_i . The PLR sequence of δ_i can be readily obtained by feeding D_A to Θ_i and then extracting the per-sample representations at the penultimate layer, i.e., the second last layer, and concatenating them one by one. For instance, assuming that the mapping function of Θ_i is $g_{\Theta_i} : x \in \mathcal{R}^{l \times w \times h} \rightarrow r \in \mathcal{R}^p$ where l, w , and h denote the width, height, and channels of an image input, respectively, and p the size of PLR. The PLR sequence of δ_i is thus $\text{PSeq}_i = \{g_{\Theta_i}(x_1), \dots, g_{\Theta_i}(x_m)\}$, where m is the size of D_A .

Step 3: Here FLBuff is to train a supervised contrastive learning (Sup-CL) model so as to obtain better representations for benign and malicious PLRs. Given a set of labeled PLRs (i.e., benign and malicious), we train the Sup-CL model using the below loss function:

$$\text{loss}_{\text{Sup-CL}} = \frac{1}{\alpha(\alpha-1)} \sum_{i=1}^{\alpha} \sum_{j=i+1}^{\alpha} (L_{i,j} + L_{j,i}), \quad (1)$$

where

$$L_{i,j} = -\log \frac{e^{\mathcal{G}(\text{PSeq}_{b,i})^T \mathcal{G}(\text{PSeq}_{b,j})/\tau}}{e^{\mathcal{G}(\text{PSeq}_{b,i})^T \mathcal{G}(\text{PSeq}_{b,j})/\tau} + \sum_{z=1}^{\beta} e^{\mathcal{G}(\text{PSeq}_{b,i})^T \mathcal{G}(\text{PSeq}_{m,z})/\tau}}, \quad (2)$$

and $\mathcal{G}(\cdot)$ is the encoder and $\tau \in [0, 1]$ a parameter that controls distribution concentration level [17].

Step 4: FLBuff is to compute a trust score for each δ_i by first using Maximum Mean Discrepancy [18] (MMD) to compute a distance $\text{MMD}(\text{PSeq}_i, \text{PSeq}_j)$ between two PLR sequences and then estimating the trust score of δ_i by counting the number of neighbors based on the computed distances:

- For δ_i , FLBuff selects the top 50% nearest neighbors based on the MMD distances in current round. The count for δ_i , denoted by Count_i , is to increase by one every time δ_i is selected as a nearest neighbor by another arbitrary δ_j ($j \neq i$).

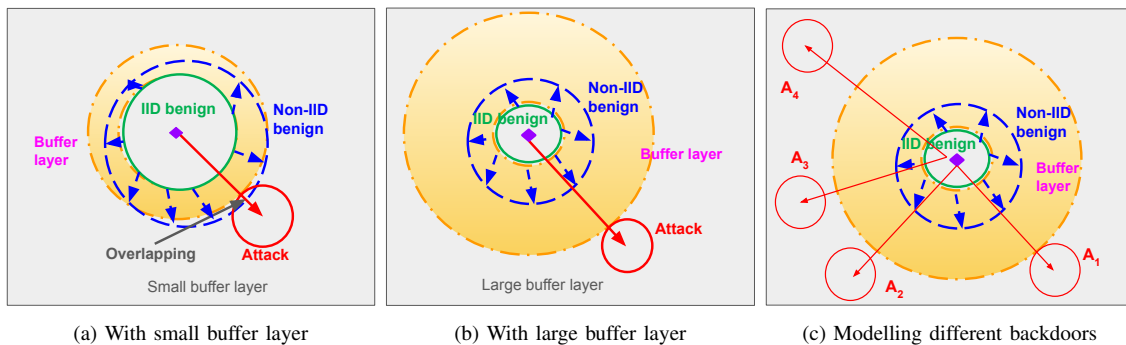

Fig. 3: A unified view for modeling the impacts of backdoor attacks and non-iids.

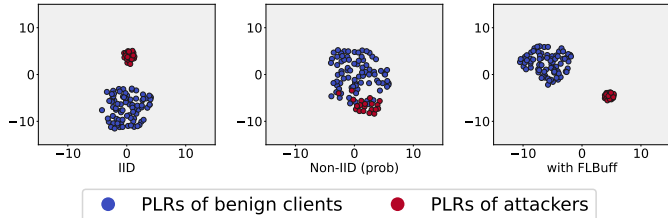

Fig. 4: Model updates for CIFAR-10 in PLR space under different scenarios: iid, non-iid (prob), and with FLBuff.

- FLBuff converts Count_i into a trust score Score_i using a softmax function: $\text{Score}_i = \frac{\exp(\text{Count}_i / \kappa)}{\sum_{k=1}^n \exp(\text{Count}_k / \kappa)}$, where κ is a temperature parameter to adjust the sensitivity of Score_i . $\kappa = 1$ is used in FLBuff.

Step 5: Finally, FLBuff aggregates all δ_i s using Score_i and updates Θ by $\Theta \leftarrow \Theta + \sum_{i=1}^n \text{Score}_i \cdot \delta_i$.

IV. PERFORMANCE EVALUATION

A. Experimental Settings & Goals

1) *Implementation:* We implemented FLBuff in PyTorch. The experiments were executed on a server with two NVIDIA RTX 3090 GPUs.

2) *Datasets and Models:* We evaluated FLBuff on three image datasets as in [6], [7], [9] and one additional text dataset: MNIST, Fashion-MNIST (FMNIST), CIFAR10, and IMDB. For iid scenarios, we divide the data equally among clients. For non-iids, we consider five non-iid types with the following default non-iid parameters: **1)** prob-based (0.3), **2)** dir-based (0.3), **3)** qty-based where each client only has two classes, **4)** noise-based ($\sigma = 0.5$), and **5)** quantity skew with $\beta = 0.5$ for Dirichlet distribution. We also explore different non-iid degrees in ablation study at Sect. IV-B3.

We adopt a CNN model for MNIST and FMNIST, ResNet-50 for CIFAR10, and LSTM for IMDB. The details of these models are in **supplementary**.

3) *FL Settings:* In each FL round, we select 10 out of 100 clients via **random selection** to participate FL training. By default, the malicious client ratio is set to 0.2 and the data poisoning rate 0.5. Each client trains its local model using a batch size of 64 for five local epochs. The classification

threshold is set to 0.5 for the Sup-CL module. For MNIST and FMNIST, we adopt cross-entropy as the loss function, stochastic gradient descent (SGD) with a learning rate of 0.001, and a momentum of 0.9 to train models. For CIFAR10, we use the same loss function, optimizer and momentum decay but adopt a learning rate of 0.01 for SGD instead. For IMDB, we adopt cross-entropy with logit as the loss function and Adam optimizer with a learning rate of 0.001.

4) *Metrics:* We use both attack success rate (ASR) and model accuracy (Acc) to evaluate FLBuff as in [6], [7], [9]. ASR denotes the ratio of backdoor samples that successfully achieve targeted predictions from the victim FL model. The lower ASR, the better FLBuff performs. Acc denotes the classification accuracy of the targeted FL model (i.e., the victim model) during testing.

5) *Baselines:* We evaluate FLBuff against four backdoors: *BadNets* [19], *DBA* [16], *Scaling* [3], and *ALIE* [4]. We compare FLBuff to five SOTA defenses: *FLTrust* [5], *FLDetector* [7], *FLARE* [6], *FLAME* [12], and *FLIP* [8].

6) *Evaluation Goals:* We introduce our evaluation goals here: **Goal 1:** providing comprehensive attack and defense benchmarks under multiple non-iid settings, **Goal 2:** evaluating the effectiveness of FLBuff, and finally **Goal 3:** evaluating defense effectiveness under various settings including an adaptive attacker.

B. Experimental Results

1) *Performance of Global Models:* Table III shows the accuracy of **clean global models without attacks** under iid and five non-iids. The results indicate that model accuracy decreases in non-iids due to non-iids. It also shows that FLBuff does not negatively impact the accuracy of the global model.

2) *Performance of FLBuff and Non-iid Benchmark:* Table II shows the ASR of FLBuff and five baselines against four backdoor attacks under iid and five non-iids. **Note that** the results of FLBuff are obtained when applying the same FLBuff model trained from labeled benign and BadNets samples only to all backdoors (i.e., BadNets, DBA, Scaling, and ALIE) and all non-iids (i.e., dir, prob, qty, noise, and qs). Below are our findings from the results. **(1)** Existing defenses are not as robust as claimed when evaluated under different non-iids. For most defenses, their performance drops significantly when

TABLE II: ASR (%) of backdoor attacks with FLBuff and five baselines under iid and five non-iids.

Defense	Dataset	BadNets						DBA						Scaling						ALIE					
		iid	dir	prob	qty	noise	qs	iid	dir	prob	qty	noise	qs	iid	dir	prob	qty	noise	qs	iid	dir	prob	qty	noise	qs
FLTrust	MNIST	0.90	2.01	2.70	4.99	1.70	8.16	0.78	2.25	3.29	6.12	3.12	10.75	0.46	4.17	3.20	10.96	2.40	9.71	0.84	4.51	5.02	6.61	2.42	10.85
	FMNIST	0.63	4.07	3.03	7.36	2.90	10.24	1.46	4.59	6.20	8.50	3.20	9.57	2.80	3.87	5.38	11.88	5.00	8.40	0.78	3.42	2.01	8.55	4.84	7.26
	CIFAR10	2.51	10.09	7.12	10.80	5.72	13.44	1.25	8.71	7.73	13.39	8.33	10.62	0.89	13.21	7.70	15.31	4.32	48.01	0.94	11.29	8.79	17.54	6.18	12.35
	IMDB	3.09	10.22	13.17	10.75	5.40	11.60	4.03	7.35	8.04	11.01	4.50	12.57	3.27	7.09	10.55	9.15	3.90	11.27	4.23	9.47	7.41	10.31	5.91	13.88
FLARE	MNIST	0.48	3.10	2.77	2.40	2.08	12.42	0.42	2.27	2.52	0.94	3.44	8.14	0.52	1.25	2.92	5.56	3.79	10.12	0.32	6.57	5.01	7.91	3.34	8.66
	FMNIST	1.00	7.10	5.80	7.31	5.97	14.43	4.40	5.90	6.92	4.25	5.17	10.03	4.72	15.80	2.90	6.98	5.43	15.45	0.10	7.31	8.19	10.05	3.30	12.91
	CIFAR10	1.80	10.81	6.90	9.77	10.10	20.01	1.50	10.40	13.10	3.72	10.80	17.90	2.10	11.60	12.60	8.89	10.97	13.50	1.14	12.06	13.56	8.45	9.45	18.61
	IMDB	2.47	10.06	6.17	11.57	9.30	11.20	2.92	8.89	10.22	6.98	12.30	14.40	1.91	7.54	8.18	8.95	8.56	12.30	2.81	5.52	10.20	11.13	9.90	12.10
FLDetector	MNIST	0.26	8.80	5.96	10.54	1.10	10.22	1.53	3.41	8.96	12.51	1.57	6.39	2.01	4.60	4.19	16.52	2.79	10.58	0.95	5.17	5.30	8.90	3.78	10.92
	FMNIST	0.29	9.14	4.28	12.05	2.70	15.25	3.89	4.13	6.51	15.43	5.00	11.10	2.89	7.00	5.90	18.74	3.60	15.34	1.87	5.52	4.13	12.78	4.93	14.10
	CIFAR10	3.26	8.42	8.31	16.50	10.10	14.90	3.43	10.57	8.24	15.50	8.70	22.60	6.60	7.08	5.10	16.95	10.02	27.88	1.93	9.29	5.41	10.93	8.50	35.80
	IMDB	3.15	6.10	5.30	19.25	9.68	16.54	2.82	7.52	5.46	18.83	5.72	25.52	3.02	5.46	5.02	7.51	8.10	10.90	4.70	7.35	6.23	8.50	5.40	10.90
FLAME	MNIST	0.21	1.35	3.37	3.32	0.63	2.29	0.30	1.46	1.88	1.48	0.31	3.96	0.44	1.71	5.18	1.64	1.88	5.11	0.28	1.52	2.82	3.85	0.94	5.66
	FMNIST	0.75	2.10	6.58	7.86	1.52	8.10	0.43	3.30	3.55	4.53	3.64	7.24	0.91	5.51	8.23	6.15	4.37	6.10	1.74	5.70	6.72	5.60	2.10	8.00
	CIFAR10	3.20	5.10	6.50	11.10	7.80	18.60	3.30	10.60	7.70	14.51	6.50	11.80	1.80	10.60	6.80	10.72	4.10	11.00	1.15	7.80	10.70	11.25	2.73	14.50
	IMDB	1.02	3.35	7.15	9.90	5.80	10.00	1.63	6.45	10.68	9.95	4.83	9.64	2.07	8.55	6.73	10.16	6.10	10.10	2.12	8.75	6.85	10.30	3.00	10.60
FLIP	MNIST	1.13	5.11	7.27	8.32	1.42	4.87	2.10	10.82	11.40	12.38	5.35	2.44	1.22	5.53	8.98	9.54	2.10	4.68	3.21	8.65	12.52	8.75	3.85	7.51
	FMNIST	0.30	4.98	4.58	10.76	2.71	5.38	4.14	10.41	8.85	12.63	1.24	6.90	1.11	12.36	9.13	9.05	0.73	5.97	2.14	7.36	8.82	8.70	4.90	4.83
	CIFAR10	3.20	8.78	9.90	14.30	6.88	24.20	6.60	7.44	8.80	10.61	12.70	27.90	5.60	8.69	7.90	10.81	7.20	15.40	1.45	10.91	11.10	14.35	9.00	21.80
	IMDB	3.12	9.45	10.25	12.00	4.50	10.20	5.73	13.55	7.78	12.05	5.45	11.70	2.17	21.65	22.83	13.26	3.70	8.40	3.22	11.85	9.95	13.40	6.20	15.30
FLBuff	MNIST	0.30	1.00	0.70	0.52	0.98	0.65	0.56	1.27	0.90	1.40	0.70	0.85	0.15	0.12	0.43	0.28	0.71	0.60	0.93	1.07	1.25	0.42	1.14	0.53
	FMNIST	0.85	0.53	0.87	1.23	0.53	0.51	0.15	0.25	0.47	0.22	1.12	0.49	0.62	0.31	0.92	0.76	0.65	0.81	0.76	0.74	0.38	1.07	0.95	0.85
	CIFAR10	0.30	0.93	0.94	0.77	0.80	0.62	0.51	1.28	0.55	1.42	1.19	0.65	0.35	1.13	0.77	0.81	0.54	1.20	0.04	0.19	1.26	1.01	0.68	1.09
	IMDB	0.35	0.33	0.89	0.50	0.60	0.94	0.62	1.18	1.10	1.18	0.74	0.70	0.85	1.26	0.93	1.05	0.72	1.05	0.97	0.22	0.29	0.86	0.84	0.91

TABLE III: Acc without backdoor attacks on FL.

Dataset	iid	dir	prob	qty	noise	qs
MNIST	99.50	95.84	94.23	94.18	97.36	94.27
FMNIST	85.51	80.86	79.68	79.30	80.58	80.10
CIFAR-10	68.53	65.49	65.20	65.59	67.50	65.14
IMDB	87.60	85.20	83.36	82.52	85.69	84.01

the scenario goes from iid to an arbitrary non-iid. For instance, ASR of FLTrust under non-iids changes vastly between 0.46% to 48.01%. (2) While certain defenses may remain effective under a specific non-iid type, it is rare that they perform well across more than two non-iids. One possible reason is the lack of built-in design for addressing non-iids in these defenses. (3) In comparison, FLBuff achieves the best performance among all. Most ASR using the same FLBuff model across various non-iids and backdoors is low around 1% while ASR with other defenses easily exceeds 15% or even 20%. The results in Table II confirm FLBuff can consistently defend FL models against various backdoors under different non-iids.

We want to emphasize that our work provides a friendly and extendable benchmark for any FL evaluations regarding non-iids, which has been missing in the literature.

3) *Ablation Study: Impact of non-iid degree.* For convenience, we first normalize all non-iid degrees to $[0, 1]$. Intuitively, a large non-iid degree leads to severe expansion of non-iid, which makes it more difficult to defend (see Fig. 3a). Fig. 5a shows the impact of non-iid degree on FLBuff, from which we have two observations. (1) The ASR without FLBuff increases as non-iid degree increases indicating that a larger non-iid degree harms the FL model more severely. (2) In comparison, when non-iid degree increases, it only impacts FLBuff slightly, hence rendering FLBuff a robust defense towards non-iid degree. Results for ‘noise’ and ‘qs’ can be found in **supplementary**.

Impact of the number of attackers. Fig. 5b shows the impact of the number of malicious clients on FLBuff. (1) We observe that without FLBuff, more attackers can lead to higher

ASR under iid and non-iid settings. (2) FLBuff can effectively mitigate backdoors as it achieves low ASR even when the number of attackers increases.

Impact of data poisoning rate. Fig. 5c shows ASR at different poisoning rates. (1) ASR increases with higher poisoning rates without FLBuff. (2) FLBuff remains largely unaffected with increasing rates.

Impact of classification threshold γ . Fig. 5d illustrates the impact of classification threshold on FLBuff. The results confirm that γ would not affect ASR of FLBuff much as long as it is not too low (e.g., ≤ 0.2) nor too high (e.g., ≥ 0.9).

Impact of auxiliary dataset. We tested if public datasets could replace the original auxiliary data in Step 2 as alternatives, e.g., using EMNIST samples for MNIST. Table IV shows that this led to minimal changes in ASR, confirming that FLBuff would not rely on specific auxiliary datasets.

TABLE IV: Impact of auxiliary datasets on FLBuff (ASR), Scaling

#Seq	Train-Set & Auxiliary-Set	iid	dir	prob	qty	noise	qs
Pair1	MNIST	0.20	0.10	0.50	0.30	0.70	0.60
	EMNIST	0.27	0.15	0.53	0.26	0.74	0.58
Pair2	FMNIST	0.69	0.40	0.98	0.75	0.65	0.80
	KMNIST	0.75	0.50	1.10	0.90	0.70	0.86
Pair3	CIFAR-10	0.40	1.10	0.72	0.80	0.55	1.22
	CIFAR100	0.50	1.25	0.88	0.95	0.62	1.31
Pair4	IMDB	0.90	1.30	0.90	1.03	0.70	1.00
	Sentiment-140	1.02	1.40	1.10	1.15	0.90	1.11

TABLE V: ASR (%) with FLBuff under adaptive attacks

Dataset	iid	dir	prob	qty	noise	qs
MNIST	0.20	0.42	1.37	0.35	0.72	0.93
FMNIST	0.96	1.35	1.86	0.60	1.38	1.50
CIFAR-10	1.15	1.50	1.09	1.06	0.73	1.09
IMDB	0.57	1.38	1.03	0.42	1.00	1.34

4) *Resilience to Adaptive Attacks under Non-iids:* As in prior defenses, we expect that resilience to adaptive attacks is critical for FLBuff. Given knowledge about FLBuff, an attacker’s goal is to use adaptive attacks to bypass FLBuff and successfully compromise Θ . Our key differences from

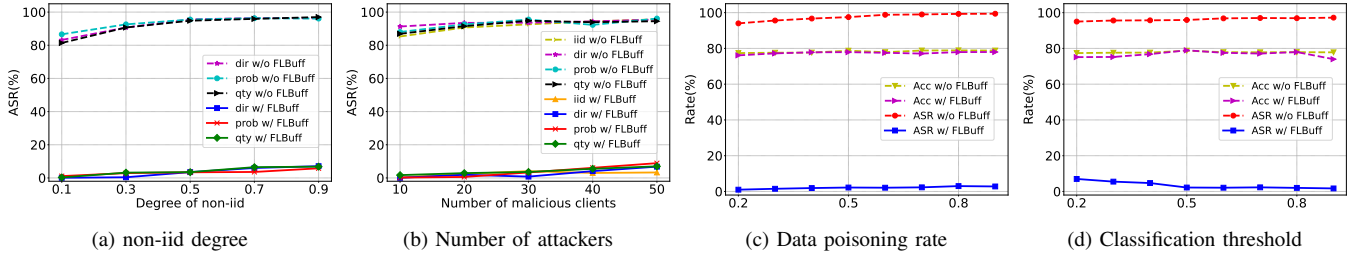

Fig. 5: Impact of various factors on FLBuff on CIFAR10 with Scaling attack.

others are (1) prior works rarely evaluated a defense against adaptive attacks under non-iids while we do. Moreover, we believe non-iid settings are necessary for evaluating adaptive attacks because non-iids are fundamental in FL and effectively facilitate adaptive attacks. (2) We further consider stronger adaptive backdoors by normalizing the loss terms when formulating adaptive attacks.

Our adaptive attacker is to craft her malicious model updates and the corresponding PLRs so that they resemble those of benign model updates. The formulation is as below while more details are in **supplementary**.

$$\arg \min_{\delta_{mal}} L(\mathcal{D}_{mal}) + \lambda L(\mathcal{D}_{train}) + \rho \Delta \tilde{d}_{\delta} + \eta \tilde{d}_{plr}, \quad (3)$$

where $L(\mathcal{D}_{mal})$ denotes the loss on targeted backdoored inputs, $L(\mathcal{D}_{train})$ the loss on clean dataset, $\Delta \tilde{d}_{\delta} = \frac{\|\delta_{mal} - \bar{\delta}_{ben}\|}{\|\delta_{mal} - \bar{\delta}_{ben}\|_{max}}$ the normalized distance between malicious model updates and average benign ones, and finally $\tilde{d}_{plr} = \frac{d_{plr}}{d_{plr,max}}$ the normalized distance between the PLRs of malicious model updates and the average one of benign models. λ , ρ , and η are the corresponding coefficients. Table V lists the resulted ASR of the above adaptive attack on FLBuff. The results confirm that FLBuff still achieves low ASR against adaptive attacks particularly across various datasets and all the five non-iids.

V. RELATED WORK

A. Backdoor Attacks

The recent years have seen many novel backdoor attacks featuring their unique attack strategies. For instance, BadNets [19] introduced an embedded trigger to enforce specific model outputs, while Xie et al. [16] extended this approach to distributed settings with DBA. Scaling [3] and ALIE [4] further demonstrated the feasibility of stealthy backdoor attacks. Our paper adopts recent popular backdoor attacks which have been shown to bypass strong defenses.

B. Defenses against Backdoor Attacks

FLTrust [5] aggregated model updates by computing a trust score based on their direction and magnitude similarity. FLARE [6] collected PLRs for better characterizing model updates and then computing trust scores for aggregation as well. FLAME [12] used clustering and weight clipping to

estimate and inject minimal noise for mitigating backdoors. Zhang et al. [8] utilized reverse engineering to identify backdoor triggers. FLDetector [7] filtered out malicious model updates using historical data and consistency check. CrowdGuard [9], MESAS [10], and FreqFed [11] are the few most recent defenses aiming to address non-iid challenges as well. Aside from unique assumptions on hardware (e.g., CrowdGuard required TEE for secure computation) and backdoor strategies (e.g., FreqFed assumed unique attack patterns in frequency domain), they still suffer from insufficient non-iid comprehensiveness as shown in Table I.

Differences in FLBuff. Firstly, FLBuff considered the most comprehensive and important set of non-iids. Secondly, the design of FLBuff started from the very root of why prior works fail under various non-iids. Thirdly, FLBuff considered stronger adaptive attacks under non-iids as well.

VI. CONCLUSIONS

In this paper, we introduce FLBuff, a novel defense framework designed to protect FL against SOTA backdoor attacks under five types of challenging non-iids. FLBuff aims to fill the gap that existing defenses simply fail under different non-iids. We designed FLBuff as an aggregation-based defense aiming at creating a large buffer layer to separate benign and malicious clusters. Our extensive results demonstrate FLBuff’s better performance in different scenarios, including against previously unseen attacks and strong adaptive attacks as well.

REFERENCES

- [1] M. Fang, X. Cao, J. Jia, and N. Gong, “Local model poisoning attacks to byzantine-robust federated learning,” in *USENIX Security*, 2020.
- [2] E. Bagdasaryan, O. Poursaeed, and V. Shmatikov, “Differential privacy has disparate impact on model accuracy,” in *NeurIPS*, 2019.
- [3] E. Bagdasaryan, A. Veit, Y. Hua, D. Estrin, and V. Shmatikov, “How to backdoor federated learning,” in *AISTATS*, 2020.
- [4] G. Baruch, M. Baruch, and Y. Goldberg, “A little is enough: Circumventing defenses for distributed learning,” *NeurIPS*, 2019.
- [5] X. Cao, M. Fang, J. Liu, and N. Z. Gong, “Fltrust: Byzantine-robust federated learning via trust bootstrapping,” *NDSS*, 2021.
- [6] N. Wang, Y. Xiao, Y. Chen, Y. Hu, W. Lou, and Y. T. Hou, “Flare: defending federated learning against model poisoning attacks via latent space representations,” in *AsiaCCS*, 2022.
- [7] Z. Zhang, X. Cao, J. Jia, and N. Z. Gong, “Fldetector: Defending federated learning against model poisoning attacks via detecting malicious clients,” in *KDD*, 2022.
- [8] K. Zhang, G. Tao, Q. Xu, S. Cheng, S. An, Y. Liu, S. Feng, G. Shen, P.-Y. Chen, S. Ma, and X. Zhang, “Flip: A provable defense framework for backdoor mitigation in federated learning,” 2023.
- [9] P. Rieger, T. Krauß, M. Miettinen, A. Dmitrienko, and A.-R. Sadeghi, “Crowdguard: Federated backdoor detection in federated learning,” 2023.

- [10] T. Krauß and A. Dmitrienko, “Mesas: Poisoning defense for federated learning resilient against adaptive attackers,” in *CCS*, 2023.
- [11] H. Fereidooni, A. Pegoraro, P. Rieger, A. Dmitrienko, and A.-R. Sadeghi, “Freqfed: A frequency analysis-based approach for mitigating poisoning attacks in federated learning,” *arXiv preprint arXiv:2312.04432*, 2023.
- [12] T. D. Nguyen, P. Rieger, R. De Viti, H. Chen, B. B. Brandenburg, H. Yalame, H. Möllering, H. Fereidooni, S. Marchal, M. Miettinen, *et al.*, “{FLAME}: Taming backdoors in federated learning,” in *USENIX Security*, 2022.
- [13] B. McMahan, E. Moore, D. Ramage, S. Hampson, and B. A. y Arcas, “Communication-efficient learning of deep networks from decentralized data,” in *AISTATS*, 2017.
- [14] Q. Li, Y. Diao, Q. Chen, and B. He, “Federated learning on non-iid data silos: An experimental study,” in *ICDE*, 2022.
- [15] M. Luo, F. Chen, D. Hu, Y. Zhang, J. Liang, and J. Feng, “No fear of heterogeneity: Classifier calibration for federated learning with non-iid data,” *NeurIPS*, 2021.
- [16] C. Xie, K. Huang, P.-Y. Chen, and B. Li, “Dba: Distributed backdoor attacks against federated learning,” in *ICLR*, 2019.
- [17] Y. Tian, C. Sun, B. Poole, D. Krishnan, C. Schmid, and P. Isola, “What makes for good views for contrastive learning?,” in *NeurIPS*, 2020.
- [18] A. Gretton, K. M. Borgwardt, M. J. Rasch, B. Schölkopf, and A. Smola, “A kernel two-sample test,” *Journal of Machine Learning Research*, vol. 13, no. 25, pp. 723–773, 2012.
- [19] T. Gu, B. Dolan-Gavitt, and S. Garg, “Badnets: Identifying vulnerabilities in the machine learning model supply chain,” *arXiv preprint arXiv:1708.06733*, 2017.