

Challenges and Opportunities for Global Cellular Connectivity

Viktoria Vomhoff
University of Wuerzburg
Germany
viktoria.vomhoff@uni-wuerzburg.de

Hyunseok Daniel Jang
NYU Abu Dhabi
UAE
daniel.jang@nyu.edu

Matteo Varvello
Nokia Bell Labs
USA
matteo.varvello@nokia.com

Stefan Geißler
University of Wuerzburg
Germany
stefan.geissler@uni-wuerzburg.de

Yasir Zaki
NYU Abu Dhabi
UAE
yasir.zaki@nyu.edu

Tobias Hoßfeld
University of Wuerzburg
Germany
tobias.hossfeld@uni-wuerzburg.de

Andra Lutu
Telefonica Research
Spain
andra.lutu@telefonica.com

ABSTRACT

Traditional cellular service was designed for global connectivity, but business and logistical constraints led to its fragmentation, with deployments limited to individual countries and regions. Initiatives like Mobile Virtual Network Operators (MVNOs), Mobile Network Aggregators (MNAs), and regulations like “roam-like-at-home” have partially restored global service potential, though often at high costs in terms of user bills, application performance, and traffic efficiency. This paper makes two key contributions: first, it surveys the global cellular ecosystem, analyzing the strengths and weaknesses of major players using data from prior research, proprietary datasets, and public sources. Second, it argues that the technology for seamless global service exists in Local Breakout (LBO), a roaming architecture which allows user traffic to be routed directly to the Internet through the visited network, bypassing the home network and/or third-party infrastructures. However, LBO adoption is hindered by issues such as policy enforcement, billing, and Quality of Service (QoS) guarantees, rooted in a lack of trust between operators. The paper concludes by exploring technological advances that could enable LBO, and pave the way for truly global cellular connectivity.

CCS CONCEPTS

• **Networks** → **Network design principles; Mobile networks.**

KEYWORDS

Mobile Networks, Roaming, Network Optimization

1 INTRODUCTION

Traditional cellular service was designed for global connectivity, allowing mobile devices to function worldwide without the need of a separate service contract with a local operator in each visited country. This relies on a handful of telco providers that together with Mobile Network Operators (MNOs) interconnect to offer cellular connectivity in a monolithic fashion, *i.e.*, a single entity provides all the components of the mobile communications service.

As both the mobile market and the technology matured, Mobile Virtual Network Operators (MVNOs) [43, 49, 53] surfaced as a way to further exploit the infrastructure of incumbent MNOs to provide services without the need of deploying all the cellular network components. In recent years, Mobile Network Aggregators (MNAs)

– such as Airalo [2], 1Global [1] or Twilio [45] – have emerged as a disruptive phenomenon in the telco sector to provide global mobile connectivity [3, 52]. Their operational model upgrades the MVNO approach by leveraging the infrastructure of multiple base operators in different countries. To achieve this, MNAs overload the international roaming function, and benefit from the extensive global infrastructure that telcos have been shaping for decades. Specifically, all MNAs gain access to (visited) Radio Access Networks (RANs) globally via interconnection through roaming hubs [26].

Despite roaming, there is currently an intrinsic lack of trust between the Home Mobile Network Operator (h-MNO) and the Visited Mobile Network Operator (v-MNO), which ends up impacting communication performance. Specifically, the unwillingness of the h-MNO to expose to a foreign operator charging information for their users makes Home-Routed (HR) roaming the default roaming configuration. With HR, all traffic is routed through the home country, regardless of the roaming user’s actual geolocation. This allows MNOs to control the charging function of their outbound roaming users, but it also translates into a non-negligible delay penalty and potential performance impairment [12, 33].

However, despite these advancements, MNAs still face significant challenges in offering a native-like service to their roaming end-users. In this paper, we highlight the need for a truly global network architecture for cellular connectivity, where the end-users can enjoy native-like performance. We build on existing measurement studies [3, 17, 32, 33, 47] to map out the existing commercial implementations for global operators. We detail next the contributions we make in this work, as follows.

This paper presents a complete overview, at the time of writing, of MNAs models (Section 3). Depending on their type (light, thick, full), MNAs achieve varying geo-spatial granularity of breakout locations. Until now, we have seen commercial MNAs relying on the base operator’s core networks (light MNAs) or fully/partially running their own (full, thick MNAs) to provision their eSIM profiles. With the advent of embedded Subscriber Identity Module (eSIM) technology – which allows users to activate a cellular plan purely via software – some MNAs now enable travelers to avoid inconvenient (buying local SIM cards in stores) and expensive (roaming bill shock) connectivity while abroad. The combination of MNA and eSIM technology with recent advances in network virtualization [16, 21, 24] enables a new era in global mobile connectivity, characterized by varying degrees of operational complexity.

Despite creative in their setups, we explain that MNAs cannot currently offer a native-like service to their roaming end-users, for which the Local Breakout (LBO) roaming architecture – where traffic is directly offloaded at the v-MNO – is needed. We formulate the fundamental challenges that stand in the way of realizing LBO within the cellular ecosystem (Section 4). We highlight the corresponding research problems around zero-trust interaction, cross-operator security, reliable billing and ensuring consistent performance for the end-user. Our contribution here aims to put emphasis on global connectivity research, specifically towards removing unrelenting limitations.

We finally contribute a (partial) examination of potential avenues to achieve true global connectivity, and tackle (some of) the above-mentioned unrelenting challenges (see Section 5). We discuss incremental solutions, such as amplifying the MNA model to leverage multiple cloud providers, or new architecture designs, such as attempting to solve the problem at the transport layer [24], or decoupling end-user identity from their provider [42]. We note that these attempts ultimately introduce new actors into the ecosystem to facilitate or proxy the end-user’s global access to cellular resources. Thus, we also explore solutions that enable MNOs to establish roaming partnerships and exchange value directly, eliminating the need for third parties [25].

2 PRELIMINARIES

What is Global Cellular Connectivity? Roaming is a fundamental feature of cellular networks that allows users to maintain connectivity outside their home network’s coverage area, ensuring seamless global service across various visited networks. Initially a niche service for occasional travelers, roaming is now the standard mode of operation for a growing amount of extremely heterogeneous devices that need to operate in different environments around the world, with varying performance requirements.

This surge in demand for ubiquitous cellular connectivity comes both from the massive number of connected Internet of Things (IoT) devices as well as from people who are progressively switching (together with their devices) to a digital nomad lifestyle. Catering to digital nomads has led to the advent of global (virtual) operators that use roaming to provide seamless global connectivity, such as Airalo [2], Holafly [15], Yesim [51], Nomad [35], Onesim [36], AloSIM [4], Yoho Mobile [34], BNESIM [11]. At the same time, countless global IoT operators emerged [27], such as emnify [9], KORE [20] or 1Global [1]. Unlike human-generated traffic, IoT traffic involves smaller, more frequent data exchanges which often require multiple signaling messages for minimal data transmission [13]. Efficient network planning and management for transporting signaling traffic are essential to maintaining performance in future next-generation networks, particularly given the rapid proliferation of IoT devices.

Architectures, Agreements and Billing: Seamless global connectivity relies on cooperation among at least three independent stakeholders: visited network (providing the radio access), home network (managing the user’s identity), and interconnection provider. This cooperation is supported by standardized interfaces and protocols but also requires significant administrative work via roaming agreements. The home network, responsible for providing the SIM

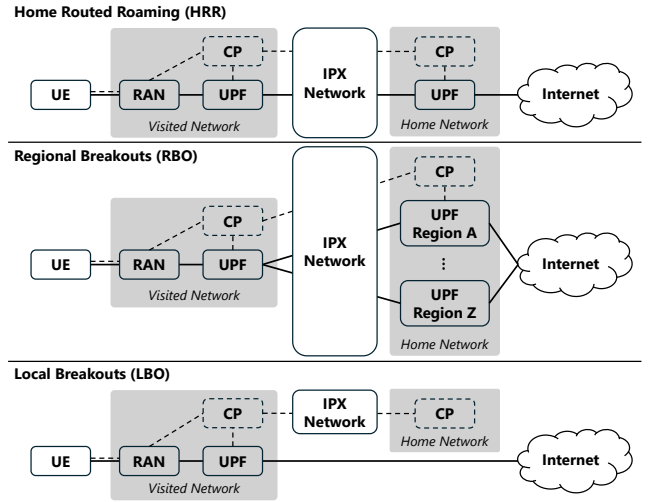

Figure 1: Simplified 5G roaming architecture. Dashed lines: control plane traffic; solid lines: user plane traffic.

identity and connectivity, serves a user’s device within its own geographical region. When the user travels outside this area, their device connects to the visited network’s radio access via roaming.

Communication between home and visited networks typically occurs via the IP Packet eXchange (IPX) network [28], traversing at most two separate carriers [27, 48]. Whether signaling traffic, user plane traffic, or both are transmitted between visited and home networks depends on the specific roaming architecture in place. Figure 1 illustrates three 5G roaming architectures: Home Routed Roaming (HRR), where all user traffic is routed through the home network, ensuring maximum control but at the cost of higher latency; Regional Breakout (RBO), which balances control and efficiency by offloading traffic at regional points closer to the user; and LBO, where traffic is directly offloaded at the visited network, minimizing latency but reducing the home network’s control over service quality and security. To ensure smooth international mobile communications, the so-called clearing houses play a crucial role by ensuring correct processing, validation, billing and accounting of mobile usage data across the different networks [29].

Mobile Virtual Network Enablers and Roaming: The conjunction of novel network softwarization and virtualization technologies – specifically eSIM technology and control and data plane separation in 5G networks – paired with the extent of cloud infrastructure deployment led to the realization of numerous global operators (be it for IoT verticals or digital nomads) – which we generically denote as MNAs. Figure 2 represents the different flavors of virtual operators, either global or restricted to a single geography.

MNAs evolve from the MVNOs operator model [54], which allows new operators to rent infrastructure from established MNOs to lower entry barriers. Unlike MNOs, MVNOs provide mobile services without owning or operating a full cellular network, specifically lacking radio spectrum ownership. To operate, an MVNO must establish commercial agreements to use the network of a base MNO.

Table 1: MNA complexity: multiple actors (table columns) within the ecosystem come together to build the MNA’s service. All aggregators depend on RAN providers, IPX Network and eSIM Platforms, and operate their own brand and sales. For Thick MNAs (emnify, Airalo), there are at least 6 different entities that coordinate to build the global connectivity service. The light MNA Google Fi only uses the cloud provider for breakout (orange cell) when the end-user activates the VPN service. The Full MNA Twilio operates their full core network over cloud infrastructure. In the "comments" we show the MNA roaming architecture and their target end-users.

	v-MNO	IPX Network	Cloud Provider	b-MNO	eSIM Platform	MNA	Comments
Google Fi	Yes	Yes	VPN Tunnel Endpoint	Data Breakout	Yes	Light MNA	HR Roaming, Nomads [3, 52]
1Global	Yes	Yes	N/A	Data Breakout	Yes	Light MNA	HR Roaming, IoT + Nomads [3]
Airalo	Yes	Yes	Data Breakout	Data Breakout	Yes	Thick MNA	RBO + HR Roaming, Nomads [17]
emnify	Yes	Yes	Cloud Core, Data Breakout	Yes	Yes	Thick MNA	RBO, IoT [47]
Twilio/KORE	Yes	Yes	Cloud Core, Data Breakout	N/A	Yes	Full MNA	HR Roaming, IoT [3]

Global Service	MNO	Light MVNO	Thick MVNO	Full MVNO	Light MNA (e.g., Google Fi, 1Global)	Thick MNA (e.g., emnify, Airalo)	Full MNA (e.g., Twilio)
Sales	MNO	MVNO	MVNO	MVNO	MNA	MNA	MNA
Core Network	MNO	b-MNO	b-MNO	MVNO	b-MNO	b-MNO	MNA
Radio Access Network	v-MNO	v-MNO	v-MNO	v-MNO	b-MNO	v-MNO	v-MNO

Figure 2: Network operating models: MVNOs lacks ownership of radio spectrum resources; light/thick MVNOs rely on a single b-MNO, and the latter’s roaming agreements for global service, while full MVNOs operate their own core network, and give global service through their own roaming agreements. MNAs run a limited part of the network (the *light* – only sales << the *thick* – limited core function << the *full* – all the core), and provide global service by exploiting the roaming agreements of several b-MNOs.

Several MVNO types exist, depending on the extent of the technological layer added over the base MNO’s network resources [44, 49]. A “thin” MVNO relies on a base MNO’s RAN and core network, while managing its own customer support, marketing, and pricing. A “thick” MVNO partially operates its own core network infrastructure for greater control but still relies on a base MNO for some functions, focusing on brand differentiation and additional services. A “full” MVNO operates its own core network, relying on a base MNO only for access to radio resources.

The underlying infrastructure that supports MVNOs is the IPX network, which interconnects virtually all MNOs world-wide [26] (even the ones within the same economy). In other words, the very same interconnections within the cellular ecosystem that enable (national/international) roaming are the ones that also supports the realization of MVNOs. IPX providers act as mobile virtual network enablers, and the activation of a full MVNO is similar to that of an international roaming agreement for HRR.

MNAs rely on the core networks of base operators (*Light MNAs*) [1, 14] or run their own (*Full MNAs*) [3, 52] to provision their eSIM profiles. Both models gain access to (visited) radio access networks globally via interconnection through roaming hubs [26]. *Thick MNAs*

push this model further, and decouple the internet gateway location from both the base MNOs’ and the visited operators’ infrastructure. For example, Airalo [2] is a popular thick MNA [17], which has gained more than 5 million customers since its inception in 2019. Emnify [9] leverage a similar operational model focused on IoT-specific global connectivity: where they use seven different cloud locations as roaming breakout points, all from the same provider.

3 REALITY CHECK ON GLOBAL CELLULAR CONNECTIVITY

We dissect here the commercial implementations of *global* cellular connectivity which we identified at the time of writing.

3.1 Evolving From HR Roaming

Global cellular service relies on international roaming, with HR being the preferred setup, even for 5G networks [12]. MNAs were designed to reduce the inefficiencies associated with HR, and improve performance by dynamically switching between Base Mobile Network Operators (b-MNOs) from different countries, thus reducing the delay penalty of HR.

MNAs are still built on the same trust model as international roaming, while allowing for service delivery almost worldwide. By aggregating network resources and functions provided by different actors (e.g., RAN resources from different v-MNOs, data breakout from the b-MNOs), MNAs implicitly fragment the end-to-end service across different network domains. Switching the b-MNO used by an MNA results in a different location for data breakout to the Internet, while still relying on the HR roaming architecture, where the “home” is the respective b-MNO. The b-MNO choice varies based on factors like policy, coverage, or performance.

3.2 Mapping MNA Breakout

Previous work conducted active measurements to map breakout locations given variable measurement vantage points and MNAs [3, 32, 33, 47]. The findings of these studies unveil how MNAs are gradually exploiting the idea of swapping b-MNO (and implicitly their corresponding breakout locations) or – in the case of thick MNAs – deploying internet gateways independently from the b-MNO in breakout locations closer to the end-user, all in an effort to reduce the implications of the HR roaming setup [12, 32]. Table 1 gives an overview of the way in which specific MNAs (namely, Google Fi, 1Global (previously known as Truphone), Airalo, emnify and Twilio) build their service.

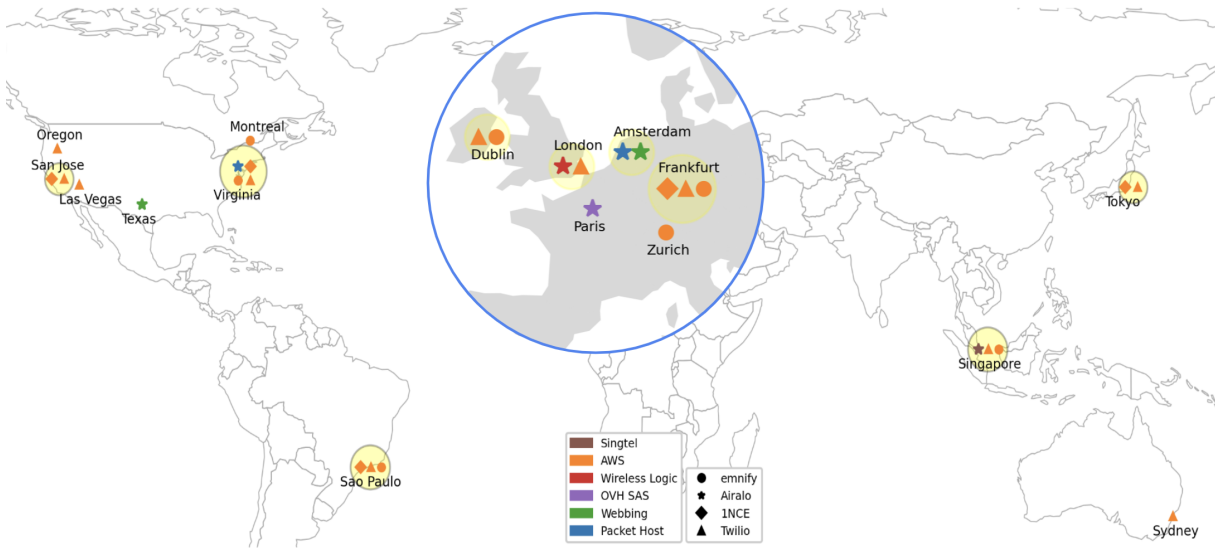

Figure 3: Map showing the geolocation of public internet gateways for various commercial eSIM providers—1NCE, Airalo, emnify, and Twilio—represented by different symbols. Colors denote the network providers hosting these gateway functions.

Depending on their setup (see classification in Table 1 according to the taxonomy from Section 2), MNAs achieve different levels of geo-spatial granularity in terms of the breakout locations. Figure 3 illustrates the geographic distribution of locations hosting internet gateway functions utilized by some commercial MNAs. These gateways deploy across different network providers, including cloud service providers (AWS, Packet Host, OVH SAS), a telecom carrier (Singtel), and IoT platforms (Webbing, Wireless Logic). We use public documentation to collect this data for 1NCE, emnify, and Twilio, which specifies the AWS regions hosting their gateways. For Airalo, we use the results of a measurement study with volunteers using Airalo eSIMs across different countries to infer (some of) the network host and geolocation data [17].

Continent-level breakout (e.g., Google Fi): Google Fi is a *light MNA* that relies on T-Mobile in the US, and Three UK in Europe [3]. Fi targets users in the US, and also offers global roaming coverage. For users traveling from the US to Spain, Fi swapped the base MNO from T-Mobile to Three UK. The use of RBO in Europe on top of Three’s network helps Fi to reduce significantly (i.e., from $\approx 200\text{ms}$ to $\approx 75\text{ms}$) the delay their users experience in Europe, whenever the VPN service is not active. This service allows users to maintain the same online experience abroad as they have at home, including access to geo-restricted content.

Country-level breakout (e.g., 1Global): 1Global (previously known as Truphone) is a *light MNA* that aggregates separate individual MVNO agreements from the nine economies where they register. 1Global was, in fact, the closest – according to measurement campaign in [3] – to deliver native-like mobile connectivity to global users. This is achieved by mapping the breakout point to the closest MVNO partnerships to the aimed service location. Leveraging their mature setup with different MVNO partnerships in over nine economies, 1Global delivers the closest performance to the one provided by a local MNO in any of those countries.

Sponsored Roaming and Cloud Breakout (e.g., emnify, Twilio, Airalo): emnify is a cloud-based platform for global cellular IoT connectivity, allowing businesses to manage IoT devices across networks without multiple SIM cards or MNO contracts. It operates seven breakout regions worldwide – hosted on AWS – where data exits the cellular network to the internet or private networks, reducing latency and enhancing data transmission speed [47].

Airalo is a prominent example of a *thick MNA*, leveraging the deployment of internet breakout gateways in multiple third-party (cloud) network infrastructures that are decoupled from both the base and the visited MNOs. In theory, this mode of operation allows for the benefits of RBO, particularly the dynamic traffic routing and prioritization of User Plane Functions (UPFs) closer to the user. In practice, Airalo eSIMs are configured to statically route traffic through specific internet gateways, often resulting in geographically suboptimal data paths. For example, its eSIMs for Azerbaijan, Finland, Moldova, and Kenya use Telecom Italia as b-MNO [17], but their roaming traffic consistently relies on RBO via UPFs in London, operated by Wireless Logic. Airalo’s performance measurement across 21 countries found that while RBO eSIMs offered better latency compared to HR counterparts, they showed minimal improvement in bandwidth [17]. This highlights the challenge of RBO operations due to complex interplay of agreements among MNOs, IPX providers, and network infrastructure companies.

Finally, Twilio is a *full MNA* that operate their own cloud-ified core network [3], and their own Mobile Country Code (MCC)-Mobile Network Code (MNC). It uses HR roaming to their own core locations hosted in cloud infrastructure.

4 LBO FOR GLOBAL CONNECTIVITY

The previous section highlighted inefficiencies in current MNAs’ solutions for global cellular connectivity. We identify LBO as a

Table 2: Challenges and opportunities of Local Breakouts (LBO) for international mobile roaming.

Aspect	Challenges	Opportunities
Trust & Billing	The lack of trust between entities regarding security, authorization, or billing hinders efficient cooperation and optimal service performance.	Develop standardized zero-trust frameworks for secure inter-operator interactions in 6G networks, to enhance global cellular connectivity, prevent roaming billing disputes, and support dynamic billing models.
RQ: How can trust between parties be ensured on a technical level?		
Security & Service Monitoring	Maintaining consistent security and privacy policies across independent networks and operators.	Potential to implement specialized and localized security measures (enabled via. e.g. global standardized APIs, standardized network data representation), tailored to specific regional requirements.
RQ: How can specialized security and service monitoring mechanisms be deployed across operator boundaries?		
Regulatory	Complying with different regulatory requirements in various regions is complex and resource-intensive.	Enhanced transparency and credibility in carbon footprint reporting, improving stakeholder trust.
RQ: How can compliance with diverse regulatory environments be managed efficiently?		
Quality of Service (QoS)	Potential variability in service quality across different visited networks.	Improved QoS for local content and services due to reduced latency and localized traffic handling.
RQ: How can QoS be improved to ensure consistent service quality across visited networks?		
Application Layer	Impact on services due to geolocation and distance from home country and content.	Utilizing advanced techniques to handle data locally, thereby reducing latency and improving service performance.
RQ: How can localized data handling mitigate the impact of geolocation and distance on services?		

promising technological advancement to address performance issues in RBO or HR architectures. This section explores the migration from HR to LBO roaming, outlining the associated opportunities and challenges within the cellular ecosystem. Table 2 provides a concise overview, including research questions for each aspect.

Trust & Billing: Although LBOs are technically feasible, their adoption is hindered by a lack of trust within the mobile ecosystem. Third-party networks may not follow the same security standards, risking data breaches and unauthorized access [23]. Trust is essential for accurate billing, financial settlements, and fraud prevention, requiring precise data tracking and real-time reconciliation between home and visited networks [29].

Implementing zero-trust frameworks, distributed ledgers for transparent transactions [8, 30, 38], advanced cryptography [40], and international regulatory harmonization [37] can address these challenges by creating standardized trust and security frameworks. Regulatory support can further enhance trust and compliance.

Security & Service Monitoring: Trust issues between mobile entities raise concerns about traffic handling and privacy, particularly in LBO, where user traffic is controlled by visited networks with varying security standards [5, 50]. Strong authentication and authorization are crucial [6, 18, 31].

Shifting control to the visited network offers opportunities for region-specific security optimization [23], enabling better protection against local threats and easier compliance with regional regulations. However, the key challenge lies in developing methods and architectures that allow home network functions to be effectively carried out within the visited network.

Regulatory Aspects: Regulatory compliance, especially with data sovereignty laws like GDPR [46], complicates LBO deployments, as these laws vary by country. Ensuring local breakouts meet both home and visited countries' legal requirements, including lawful

interception, is challenging. Previously monitored by the home network, accessing the same data in LBO deployments is not straightforward [7], requiring clear data ownership in roaming agreements.

Another key regulatory concern is the reporting of CO2 emissions within the corporate carbon footprint [19]. Companies must report the following CO2 emissions: Scope 1 (direct emissions from owned sources), Scope 2 (emissions from purchased energy), and Scope 3 (all other indirect emissions in the value chain). Therefore, the classification of emissions from roaming customers needs to be clarified, as they could be Scope 1 for the visited network or Scope 2 or 3 for the home operator.

Quality of Service: Varying Quality of Service (QoS) standards among MNOs complicate establishing Service Level Agreements (SLAs) that ensure consistent QoS for users [47]. Although LBOs may offer higher QoS than HRR (see Section 2), the home operator loses QoS control, with the visited network only providing QoS level the user pays for. Further, QoS gains may be less evident for services hosted near their home network.

LBOs also complicate the support of proprietary features such as VPNs or real-time data tracking, typically managed by the home network [10]. To address this, visited networks could offer Infrastructure-as-a-Service (IaaS) components, allowing home operators to deploy custom features, like region-specific content filtering or localized firewall services. However, this approach risks fragmentation and inconsistencies, as each visited network may implement such features differently.

Application Layer: Transitioning to LBOs means assigning roaming devices public IP addresses from the visited network, affecting services like IP geolocation and content delivery. This can impact service performance, user experience, and application functionality, with users potentially receiving localized content or experiencing higher latency depending on where a service is hosted. While local breakouts improve efficiency for geo-distributed services (e.g. on

CDNs), they might have little to no, or even negatively impact, applications hosted near the home network. However, localized data handling can optimize service delivery based on regional needs.

5 TOWARDS TRUE GLOBAL SERVICE

Traditionally, cellular service relies on the International Mobile Subscriber Identity (IMSI), a permanent and globally-unique identifier that is stored on a Subscriber Identity Module (SIM) card for both billing and authentication functionality as well as mobility and connectivity. True global aggregation of cellular resources should allow end-users (and their IMSI) to access radio networks on-demand from any available operator world-wide – regardless of size or trust level – and do so in real-time. Attempting to achieve this in a setup where the end-user identity is akin to the (sole) connectivity provider issuing the IMSI is restrictive.

We next explore both incremental and clean-slate approaches to achieving true global service, including innovative cellular architectures that eliminate existing barriers to multi-network access for users worldwide.

Amplifying the Thick MNA Model: With the materialization of MNAs such as Google Fi, 1Global, emnify, Airalo or Twillio, the cellular ecosystem evolved in terms of complexity, with data paths that were once confined to a single operator realm now traversing multiple domains, and relying on resources from different entities (including the RAN provider, the b-MNO, the gateway provider, or IPX provider). Although creative, these operators still built on the very same trust model of the cellular ecosystem, and thus suffer from the limitations of combining international roaming and virtual operator design (see Section 4). One avenue to explore is evolving the *thick MNA* model to dynamically deploy Internet gateways over the underlying infrastructure of multiple providers. Figure 3 highlights an existing concentration of internet breakout locations in specific cities, such as Frankfurt, Sao Paulo, Singapore, and Virginia, indicating these cities as major hubs for global roaming connectivity. This incremental solution could enhance the geospatial granularity of breakout locations, potentially achieving LBO-like (native) performance (see Section 4).

Cellular Aggregation at the Transport Layer: One promising approach to achieving global service is aggregating cellular networks at the transport layer, using multiple networks simultaneously to provide data service and mask the interruptions of any single network. Early research trying to apply Multipath TCP (MPTCP) directly onto two cellular networks in the high speed mobility case points out that this vanilla attempt achieves little enhancement, or even occasionally performed worse compared to a single good path, due to imbalanced congestion window (cwnd) distribution by coupled congestion control algorithm and an exaggerated out-of-order problem from frequent handovers [22].

Combining architecture design with aggregation at the transport layer and Distributed Ledger Technology (DLT) [39], CellBricks [24] proposed to move support for mobility from the network to the user device, so that a user can experience seamless mobility, even if they frequently switch between mobile providers. However, these solutions require several changes, including modifications to cellular core software functions, updates to User Equipment (UE) firmware,

and configuration changes to enable MPTCP in the network software stack on both clients and servers.

Decoupling End-user Identity From Their Provider: Another potential avenue to enable global access to cellular networks is decoupling the identity of the end-user from the cellular infrastructure provider. Pretty Good Phone Privacy (PGPP) [41, 42] decouples billing and authentication from the cellular core, altering it to use an over-the-top oblivious authentication protocol to an external server, also supported through DLT. This can be operated by a second organization, while leaving mobility and connectivity functions in the core as they were.

MNO Consortium: The above-mentioned approaches combine the innovation potential of DLT with architectural changes that enable global cellular service. However, they all propose the introduction of new actors within the ecosystem, which would support or act as proxies for the end-user’s true global access to cellular resources. We explore here solutions that allow MNOs to engage in a roaming partnership and to exchange value easily, without the need of a third party to act as a trusted intermediary with the role to verify the interaction between the roaming partners.

The solution of cooperation among the MNOs through dynamic interconnection in the cellular ecosystem (DICE) simplifies the current roaming architecture, and allows for decentralized authentication of end-users looking to access resources globally [25]. The shift in the business logic that DICE brings through the use of cryptocurrencies allows for zero-trust global charging, without leaving the doubt that fraud (e.g., tampering with roaming records) might occur, thus promoting the local breakout roaming configuration. DICE makes a two-fold contribution to disrupt the cellular ecosystem: (i) enables MNOs to have a direct dynamic cooperation in a private and secure setup, establish roaming relationships, and perform data and financial clearing in almost real time, and (ii) enables the end-user to have control over her mobile connection and connect to a network in a visited country as a native user, receiving optimal service performance. The DLT solution lowers uncertainty about the identity of the different entities involved in the roaming transaction (i.e, the roaming user, the home network and the visited network offering roaming services to the roaming user), and allows the exchange of value without trust between the entities.

REFERENCES

- [1] 1Global. [n. d.]. Global telecom solutions to scale your Business. <https://www.1global.com/>.
- [2] Airalo. [n. d.]. Buy eSIMs for international travel. <https://www.airalo.com/>.
- [3] Sergi Alcalá-Marín, Aravindh Raman, Weili Wu, Andra Lutu, Marcelo Bagnulo, Ozgu Alay, and Fabián Bustamante. 2022. Global mobile network aggregators: taxonomy, roaming performance and optimization. In *Proceedings of the 20th Annual International Conference on Mobile Systems, Applications and Services*. 183–195.
- [4] AloSIM. [n. d.]. Up to 85% off prepaid eSIM data in 175+ countries. <https://alosim.com/>.
- [5] Anastasios N Bikos and Nicolas Sklavos. 2012. LTE/SAE security issues on 4G wireless networks. *IEEE Security & Privacy* 11, 2 (2012), 55–62.
- [6] Pousali Chakraborty, Marius Corici, Hemant Zope, Carlos Barjau, Muhammad Faheem Awan, Josep Ribes, Aaron Montilla Vicent, David Gomez-Barquero, and Thomas Magedanz. 2023. A Framework for Roaming between 5G Non-Public-Networks (NPNs). In *2023 IEEE Conference on Standards for Communications and Networking (CSCN)*. IEEE, 247–253.
- [7] Ashutosh Dhar Dwivedi, Rajani Singh, Keshav Kaushik, Raghava Rao Mukkamala, and Waleed S Alnumay. 2024. Blockchain and artificial intelligence for

- 5G-enabled Internet of Things: Challenges, opportunities, and solutions. *Transactions on Emerging Telecommunications Technologies* 35, 4 (2024), e4329.
- [8] Safwan Elmadani, Salim Hariri, and Sicong Shao. 2022. Blockchain Based Methodology for Zero Trust Modeling and Quantification for 5G Networks. In *2022 IEEE/ACS 19th International Conference on Computer Systems and Applications (AICCSA)*. IEEE, 1–9.
- [9] Emnify. [n. d.]. IoT Connectivity As Unique As Your Business. <https://www.emnify.com/>.
- [10] emnify. 2023. Integration guides | emnify Documentation — docs.emnify.com. <https://docs.emnify.com/integration-guides>. [Accessed 31-07-2024].
- [11] BNE: Best Network Ever. [n. d.]. Get your eSIM Stay connected wherever you are. <https://my.bnesim.com/>.
- [12] Rostand AK Fezeu, Claudio Fiandrino, Eman Ramadan, Jason Carpenter, Daqing Chen, Yiling Tan, Feng Qian, Joerg Widmer, Zhi-Li Zhang, et al. 2024. Roaming across the European Union in the 5G Era: Performance, Challenges, and Opportunities. In *IEEE International Conference on Computer Communications*.
- [13] Stefan Geißler, Andra Lutu, Florian Wamser, Thomas Favale, Viktoria Vomhoff, Michael Krolkowski, Marco Mellia, Diego Perino, and Tobias Hofffeld. 2024. Untangling IoT Global Connectivity: The Importance of Mobile Signaling Traffic. *IEEE Transactions on Network and Service Management* (2024).
- [14] Google. [n. d.]. Google Fi Wireless . <https://fi.google.com/about?pli=1>.
- [15] Holafly. [n. d.]. Stay connected wherever you go. <https://esim.holafly.com/>.
- [16] Vivek Jain, Hao-Tse Chu, Shixiong Qi, Chia-An Lee, Hung-Cheng Chang, Cheng-Ying Hsieh, K. K. Ramakrishnan, and Jyh-Cheng Chen. 2022. L25GC: a low latency 5G core network based on high-performance NFV platforms. In *Proceedings of the ACM SIGCOMM 2022 Conference (Amsterdam, Netherlands) (SIGCOMM '22)*. Association for Computing Machinery, New York, NY, USA, 143–157. <https://doi.org/10.1145/3544216.3544267>
- [17] Hyunseok Daniel Jang, Matteo Varvello, Andra Lutu, and Yasir Zaki. 2024. Unraveling the Airalo Ecosystem. arXiv:2408.14923 [cs.NI] <https://arxiv.org/abs/2408.14923>
- [18] Rabia Khan, Pardeep Kumar, Dushantha Nalin K Jayakody, and Madhusanka Liyanage. 2019. A survey on security and privacy of 5G technologies: Potential solutions, recent advancements, and future directions. *IEEE Communications Surveys & Tutorials* 22, 1 (2019), 196–248.
- [19] Lena Klaaßen and Christian Stoll. 2021. Harmonizing corporate carbon footprints. *Nature communications* 12, 1 (2021), 1–13.
- [20] KORE. [n. d.]. Harness the Power of 5G and IoT with KORE. <https://www.korewireless.com/>.
- [21] Jon Larrea, Andrew E. Ferguson, and Mahesh K. Marina. 2023. CoreKube: An Efficient, Autoscaling and Resilient Mobile Core System. In *Proceedings of the 29th Annual International Conference on Mobile Computing and Networking (Madrid, Spain) (ACM MobiCom '23)*. Association for Computing Machinery, New York, NY, USA, Article 25, 15 pages. <https://doi.org/10.1145/3570361.3592522>
- [22] Li Li, Ke Xu, Tong Li, Kai Zheng, Chunyi Peng, Dan Wang, Xiangxiang Wang, Meng Shen, and Rashid Mijumbi. 2018. A measurement study on multi-path TCP with multiple cellular carriers on high speed rails. In *Proceedings of the 2018 Conference of the ACM Special Interest Group on Data Communication*. 161–175.
- [23] Madhusanka Liyanage, Ahmed Bux Abro, Mika Ylianttila, and Andrei Gurtov. 2016. Opportunities and challenges of software-defined mobile networks in network security. *IEEE security & privacy* 14, 4 (2016), 34–44.
- [24] Zhihong Luo, Silvery Fu, Mark Theis, Shaddi Hasan, Sylvia Ratnasamy, and Scott Shenker. 2021. Democratizing cellular access with CellBricks. In *Proceedings of the 2021 ACM SIGCOMM 2021 Conference (Virtual Event, USA) (SIGCOMM '21)*. Association for Computing Machinery, New York, NY, USA, 626–640. <https://doi.org/10.1145/3452296.3473336>
- [25] Andra Lutu, Marcelo Bagnulo, and Diego Perino. 2020. DICE: Dynamic Interconnections for the Cellular Ecosystem. arXiv:2007.13591 [cs.NI] <https://arxiv.org/abs/2007.13591>
- [26] Andra Lutu, Byungjin Jun, Fabián E Bustamante, Diego Perino, Marcelo Bagnulo, and Carlos Gamboa Bontje. 2020. A first look at the ip exchange ecosystem. *ACM SIGCOMM Computer Communication Review* 50, 4 (2020), 25–34.
- [27] Andra Lutu, Byungjin Jun, Alessandro Finamore, Fabián E Bustamante, and Diego Perino. 2020. Where Things Roam: Uncovering Cellular IoT/M2M Connectivity. In *Proceedings of the ACM Internet Measurement Conference*. 147–161.
- [28] Andra Lutu, Diego Perino, Marcelo Bagnulo, and Fabián E Bustamante. 2021. Insights from operating an IP exchange provider. In *Proceedings of the 2021 ACM SIGCOMM 2021 Conference*. 718–730.
- [29] Gabriel Macia-Fernandez, Pedro Garcia-Teodoro, and Jesus Diaz-Verdejo. 2009. Fraud in roaming scenarios: An overview. *IEEE Wireless Communications* 16, 6 (2009), 88–94.
- [30] Babak Mafakheri, Andreas Heider-Aviet, Roberto Riggio, and Leonardo Goratti. 2021. Smart contracts in the 5G roaming architecture: the fusion of blockchain with 5G networks. *IEEE Communications Magazine* 59, 3 (2021), 77–83.
- [31] Mohammed Mahyoub, AbdulAziz AbdulGhaffar, Emmanuel Alalade, Ezekiel Ndubisi, and Ashraf Matrawy. 2024. Security analysis of critical 5g interfaces. *IEEE Communications Surveys & Tutorials* (2024).
- [32] Anna Maria Mandalari, Andra Lutu, Ana Custura, Ali Safari Khatouni, Özgü Alay, Marcelo Bagnulo, Vaibhav Bajpai, Anna Brunstrom, Jörg Ott, Martino Trevisan, Marco Mellia, and Gorry Fairhurst. 2022. Measuring Roaming in Europe: Infrastructure and Implications on Users' QoE. *IEEE Transactions on Mobile Computing* 21, 10 (2022), 3687–3699. <https://doi.org/10.1109/TMC.2021.3058787>
- [33] Anna Maria Mandalari, Andra Lutu, Ana Custura, Ali Safari Khatouni, Özgü Alay, Marcelo Bagnulo, Vaibhav Bajpai, Anna Brunstrom, Jörg Ott, Marco Mellia, et al. 2018. Experience: Implications of roaming in europe. In *Proceedings of the 24th Annual International Conference on Mobile Computing and Networking*. 179–189.
- [34] Yoho Mobile. [n. d.]. Stay Connected Anytime and Anywhere. <https://yohomobile.com/>.
- [35] Nomad. [n. d.]. Nomad eSIM: Prepaid Data Plan. <https://www.getnomad.app/>.
- [36] onesim. [n. d.]. Best prepaid eSIM data plans for travelers, digital nomads, and remote workers. <https://onesim.co/>.
- [37] Rohit Prasad and V Sridhar. 2023. *5G and Beyond: Formulating a Regulatory Relations*. Technical Report. Indian Council for Research on International Economic Relations (ICRIER)
- [38] Ahmed Refaey, Karim Hammad, Sebastian Magierowski, and Ekram Hossain. 2019. A blockchain policy and charging control framework for roaming in cellular networks. *IEEE Network* 34, 3 (2019), 170–177.
- [39] José Luis Romero Ugarte. 2018. Distributed ledger technology (DLT): introduction. *Banco de Espana Article 19* (2018), 18.
- [40] Dipanwita Sadhukhan, Sangram Ray, Mou Dasgupta, and Muhammad Khurram Khan. 2024. Development of a provably secure and privacy-preserving lightweight authentication scheme for roaming services in global mobility network. *Journal of Network and Computer Applications* 224 (2024), 103831.
- [41] Paul Schmitt, Jana Iyengar, Christopher Wood, and Barath Raghavan. 2022. The decoupling principle: a practical privacy framework. In *Proceedings of the 21st ACM Workshop on Hot Topics in Networks*. 213–220.
- [42] Paul Schmitt and Barath Raghavan. 2021. Pretty good phone privacy. In *30th USENIX Security Symposium (USENIX Security 21)*. 1737–1754.
- [43] Paul Schmitt, Morgan Vigil, and Elizabeth Belding. 2016. A study of MVNO data paths and performance. In *Passive and Active Measurement: 17th International Conference, PAM 2016, Heraklion, Greece, March 31-April 1, 2016. Proceedings 17*. Springer, 83–94.
- [44] Paul Schmitt, Morgan Vigil, and Elizabeth Belding. 2016. A study of MVNO data paths and performance. In *International Conference on Passive and Active Network Measurement*. Springer, 83–94.
- [45] Twilio. [n. d.]. The trusted platform for data-driven customer engagement across any channel. <https://www.twilio.com/>.
- [46] Paul Voigt and Axel Von dem Bussche. 2017. The eu general data protection regulation (gdpr). *A Practical Guide, 1st Ed., Cham: Springer International Publishing* 10, 3152676 (2017), 10–5555.
- [47] Viktoria Vomhoff, Marleen Sichermann, Stefan Gießler, Andra Lutu, Martin Giess, and Tobias Hofffeld. 2024. A Shortcut Through the IPX: Measuring Latencies in Global Mobile Roaming with Regional Breakouts. In *2024 8th Network Traffic Measurement and Analysis Conference (TMA)*. IEEE, 1–10.
- [48] Viktoria Vomhoff, Marleen Sichermann, Stefan Gießler, Andra Lutu, Martin Giess, and Tobias Hofffeld. 2024. A Shortcut Through the IPX: Measuring Latencies in Global Mobile Roaming with Regional Breakouts. In *2024 8th Network Traffic Measurement and Analysis Conference (TMA)*. 1–10.
- [49] Ao Xiao, Yunhao Liu, Yang Li, Feng Qian, Zhenhua Li, Sen Bai, Yao Liu, Tianyin Xu, and Xianlong Xin. 2019. An in-depth study of commercial MVNO: Measurement and optimization. In *Proceedings of the 17th Annual International Conference on Mobile Systems, Applications, and Services (Seoul, Republic of Korea) (MobiSys '19)*. 457–468.
- [50] Qi Xie, Dongzhao Hong, Mengjie Bao, Na Dong, and Duncan S Wong. 2014. Privacy-preserving mobile roaming authentication with security proof in global mobility networks. *International Journal of Distributed Sensor Networks* 10, 5 (2014), 325734.
- [51] yesim. [n. d.]. eSIM Mobile Data Plans for Tourism and Business. <https://yesim.app/>.
- [52] Zengwen Yuan, Qianru Li, Yuanjie Li, Songwu Lu, Chunyi Peng, and George Varghese. 2018. Resolving Policy Conflicts in Multi-Carrier Cellular Access. In *Proceedings of the 24th Annual International Conference on Mobile Computing and Networking (New Delhi, India) (MobiCom '18)*. Association for Computing Machinery, New York, NY, USA, 147–162. <https://doi.org/10.1145/3241539.3241558>
- [53] Fatima Zarinni, Ayon Chakraborty, Vyas Sekar, Samir R Das, and Phillipa Gill. 2014. A first look at performance in mobile virtual network operators. In *Proceedings of the 2014 conference on internet measurement conference*. 165–172.
- [54] Fatima Zarinni, Ayon Chakraborty, Vyas Sekar, Samir R Das, and Phillipa Gill. 2014. A first look at performance in mobile virtual network operators. In *Proceedings of the 2014 conference on internet measurement conference (Vancouver, BC, Canada) (IMC '14)*. 165–172.

ACRONYMS

b-MNO Base Mobile Network Operator. 3, 4, 6

- cwnd** congestion window. 6
- DLT** Distributed Ledger Technology. 6
- eSIM** embedded Subscriber Identity Module. 1, 3
- h-MNO** Home Mobile Network Operator. 1
- HR** Home-Routed. 1, 3–5
- HRR** Home Routed Roaming. 2, 3, 5
- IaaS** Infrastructure-as-a-Service. 5
- IMSI** International Mobile Subscriber Identity. 6
- IoT** Internet of Things. 2
- IPX** IP Packet eXchange. 2–4, 6
- LBO** Local Breakout. 1, 2, 4–6
- MCC** Mobile Country Code. 4
- MNA** Mobile Network Aggregator. 1–4, 6
- MNC** Mobile Network Code. 4
- MNO** Mobile Network Operator. 1–6
- MPTCP** Multipath TCP. 6
- MVNO** Mobile Virtual Network Operator. 1–4
- PGPP** Pretty Good Phone Privacy. 6
- QoS** Quality of Service. 1, 5
- RAN** Radio Access Network. 1, 3, 6
- RBO** Regional Breakout. 2, 4, 5
- SIM** Subscriber Identity Module. 6
- SLA** Service Level Agreement. 5
- UE** User Equipment. 6
- UPF** User Plane Function. 4
- v-MNO** Visited Mobile Network Operator. 1–3