

Secure Integration of 5G in Industrial Networks: State of the Art, Challenges and Opportunities

Sotiris Michaelides^{a,*}, Thomas Vogt^a, Martin Henze^{a,b}

^aSecurity and Privacy in Industrial Cooperation, RWTH Aachen University, Ahornstraße 55, 52074 Aachen, Germany

^bCyber Analysis & Defense, Fraunhofer FKIE, Fraunhoferstraße 20, 53343 Wachtberg, Germany

Abstract

The industrial landscape is undergoing a significant transformation, moving away from traditional wired fieldbus networks to cutting-edge 5G mobile networks. This transition, extending from local applications to company-wide use and spanning multiple factories, is driven by the promise of low-latency communication and seamless connectivity for various devices in industrial settings. However, besides these tremendous benefits, the integration of 5G as the communication infrastructure in industrial networks introduces a new set of risks and threats to the security of industrial systems. The inherent complexity of 5G systems poses unique challenges for ensuring a secure integration, surpassing those encountered with any technology previously utilized in industrial networks. Most importantly, the distinct characteristics of industrial networks, such as real-time operation, required safety guarantees, and high availability requirements, further complicate this task. As the industrial transition from wired to wireless networks is a relatively new concept, a lack of guidance and recommendations on securely integrating 5G renders many industrial systems vulnerable and exposed to threats associated with 5G. To address this situation, in this paper, we summarize the state-of-the-art and derive a set of recommendations for the secure integration of 5G into industrial networks based on a thorough analysis of the research landscape. Furthermore, we identify opportunities to utilize 5G to further enhance security and indicate remaining challenges, potentially identifying future academic potential.

Keywords: 5G, Industrial Networks, Security, Industrial Control Systems

1. Introduction

Industrial Control Systems (ICS) traditionally utilize wired technologies such as Ethernet and a variety of protocols such as Modbus, PROFINET, or EtherNet/IP, to realize the communication between the different components [1]. However, the digital transformation of production, driven by trends such as Industry 4.0 or the Industrial Internet of Things (IIoT) [2, 3], introduces new demands for performance and modernization that the next generation of industrial networks must meet. In contrast to previous wireless technologies such as Long Term Evolution (LTE) and Wi-Fi, 5G promises to fulfill the requirements for availability, low latency, reliability, the interconnection of a large number of devices, and the modernization of the networks [4]. Furthermore, 5G enables mobility and introduce new use cases such as remote-real-time control, and low latency access to cloud resources that further improve the functionality and automation of the ICS [5].

However, the integration of 5G as the communication infrastructure in industrial networks raises serious concerns due to the introduction of new security threats, its inherent complexity, and its wireless nature. Considering that, until recently,

industrial networks operated on simple, fieldbus-based systems that were isolated from other networks, these concerns are well-justified. Recent examples of cyberattacks in industrial networks, such as STUXNET [6] and the attack on the Ukrainian power grid [7], are proof that the security of industrial networks should be prioritized. These incidents demonstrate that industrial networks are becoming the targets of powerful adversaries and represent a new way of conducting warfare [8]. This becomes even more important when introducing new components to the ICS, such as the 5G system as the communication infrastructure. Despite its benefits, 5G also increases the attack surface of the ICS, by introducing new technologies, components and a wireless interface. Therefore, securely deploying and configuring all relevant components of 5G within industrial networks is of utmost importance.

Related Work. Over the years, extensive research has been conducted on 5G security, including analyses of real-world 5G implementations, comparisons of the Standalone (SA) and Non-Standalone (NSA) 5G architectures [9], and explorations of private 5G network deployment options with their associated drawbacks and benefits [10, 11, 12]. Entities such as the European Agency for Cybersecurity (ENISA) and the Federal Communications Commission (FCC) have investigated the (optional) security controls related to various components of 5G [13, 14]. However, these studies often lack consideration for the unique requirements of industrial networks. The 5G Alliance for Connected Industries and Automation (5G-ACIA) has addressed

*Corresponding author

Email addresses: michaelides@spice.rwth-aachen.de (Sotiris Michaelides), vogt@spice.rwth-aachen.de (Thomas Vogt), henze@spice.rwth-aachen.de (Martin Henze)

this gap by initiating work on 5G security in industrial networks, emphasizing aspects such as network slicing security and jamming. However, their approach for security mainly treats the 5G network as a closed-box system and thus resorts to the suggestion of using higher-layer security protocols, such as Transport Layer Security (TLS) [15]. In contrast, we argue for a need to comprehensively treat security and especially incorporating the correct deployment and configuration of the 5G network, especially in industrial networks where critical data, e.g., in the context of Time Sensitive Networking (TSN), is not protected by higher-layer security protocols. In addition to security, 5G-ACIA also identified industry’s requirements and explores potential use cases enabled by the integration of 5G [16, 17]. Finally, multiple papers such as [18, 19] were published, examining challenges and opportunities in 5G networks and its associated technologies. We differentiate ourselves by conducting our research based on industrial requirements for security, and thus prioritizing availability and safety over confidentiality and integrity.

Contributions. In this paper, we perform a comprehensive survey of the state-of-the-art of securely utilizing 5G in an industrial setting, identify open challenges, and highlight opportunities moving forward to realize a secure integration of 5G into industrial networks. To this end, we draw from previous research to summarize the state-of-the-art and to derive a set of recommendations for the secure integration of 5G into industrial networks. Our contributions can be summarized as follows:

- We provide insights into industrial networks, their unique requirements, their growing demand for wireless communication, and 5G as promising solution (Section 2).
- We summarize the state-of-the-art of securely deploying and configuring industrial 5G networks (Section 3).
- We identify opportunities to further enhance the security of an ICS by utilizing 5G (Section 4) as well as discuss open challenges and identify potential future research topics (Section 5).

Impact. Our overview of the state-of-the-art includes not only the secure deployment of a 5G network but also discusses aspects for a secure configuration and additional security controls, particularly relevant in areas where 5G security measures fall short in either mitigating or completely addressing potential threats and vulnerabilities. As such, our work is not only relevant for researchers to learn about current research on 5G security in industrial networks but also serves as a guideline for practitioners for a secure deployment and configuration of a 5G system in an industrial network.

2. Background: 5G in Industrial Networks

Industrial networks interconnect various components with different functionalities in an industrial control system (ICS), e.g., to control the physical process and monitor its state. To lay

the foundation for our work, we first explain how these components interact to control the physical process and identify the properties the underlying industrial network must satisfy for reliable operation (Section 2.1). Then, we delve into the advantages of wireless technology for industrial networks (Section 2.2), provide a concise overview of 5G systems (Section 2.3), and elucidate the role of 5G for carrying industrial data and associated benefits (Section 2.4).

2.1. Industrial Networks

ICSs are commonly employed to monitor and/or control physical processes in industrial facilities such as nuclear power plants and water treatment facilities. To fulfill its purpose, an ICS as visualized in Figure 1, is composed of several units, typically separated into three distinct levels: the field, control, and supervisory levels.

The *field level* is the bottommost tier, containing the *physical process* itself and its closely surrounding components, namely *sensors* and *actuators*. Sensors are responsible for measuring physical attributes, such as temperature and pressure, while actuators are responsible to perform physical actions, such as opening and closing valves. The *control level* contains the controllers, i.e., logic entities responsible for controlling and coordinating the operation of the ICS. The interaction between these two levels realizes a *closed-control loop* [1]: Sensors send gathered data of the physical process to the controller. Based on this data, the controller sends commands to the actuators which translate the commands to physical actions. Furthermore, the controller forwards captured data, issued commands and statistics to the topmost layer of the ICS, the supervisory level. The *supervisory level* contains various components responsible for monitoring, logging, and configuration, such as *Human Machine Interfaces (HMIs)*, *Data Historians*, and *Engineering Workstations*.

In contrast to traditional Information Technology (IT) networks, industrial networks prioritize availability, real-time operation, low latency, and safety over the typical focus on high bandwidth, confidentiality, and integrity. These distinct requirements have led to the development of wired networks focused on performance [20], often lacking basic security controls such as encryption and integrity protection, as these controls introduce additional latency overhead. In many cases, *air-gapping* [1], a method that isolates industrial networks from all other external networks, was the only security measure in place. Recent real-world attacks, such as the *Stuxnet* and the *Night Dragon* [1], proved air-gapping ineffective [21], emphasizing the urgent need to prioritize security rather than relegating it to secondary importance.

Furthermore, the demands of Industry 4.0 and the IIoT for increased automation, extensive cloud-based computational resources, and interconnection of industrial facilities make air-gapping no longer a viable option to implement. Security controls become even more critical, especially in wireless industrial networks, as propagating radio waves are more challenging to control and secure compared to data transmitted through wired connections. Within close proximity, anyone can eavesdrop on

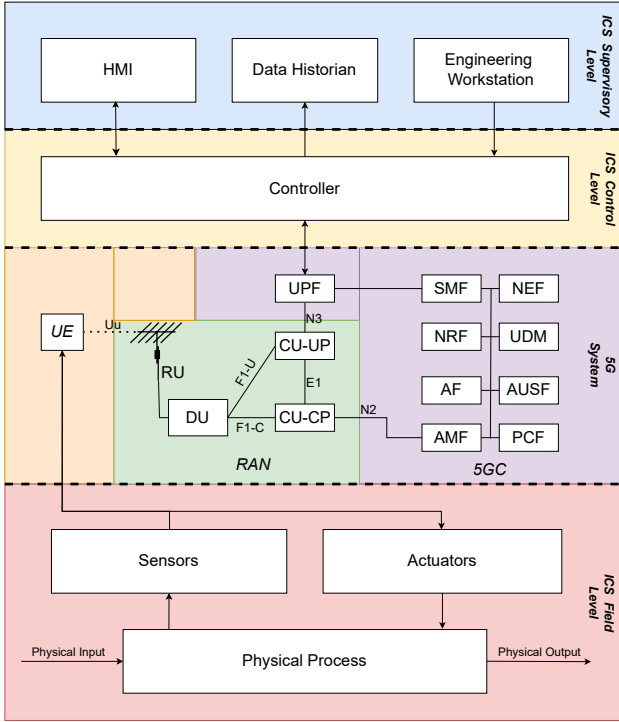

Figure 1: **Overview of a 5G-enabled ICS System:** 5G replaces the previously-wired connection between sensors/actuators and the controller. Despite its wireless nature, 5G satisfies the requirements of critical Closed-Control Loops, for low latency and real-time operation.

or tamper with the traffic [18]. Although wireless communication in industrial networks was previously uncommon, it is now considered a key-component in fulfilling the requirements of the Industry 4.0 and IIoT.

2.2. The Push for Wireless Communication

Wireless communication provides substantial advantages and enables new use cases in industrial networks [16, 17]. Firstly, wireless systems are often deemed more cost-effective than their wired counterparts due to the elimination of extensive cabling and physical infrastructure. This is particularly beneficial for factories with a vast number of IIoT sensors and redundant communication pipelines [22]. Additionally, the elimination of cables enhances scalability and flexibility. Devices can be easily installed without the need for additional hardware, and the wireless network can be accessed from virtually anywhere within its coverage area. Apart from cost reduction, cable elimination also enables mobility and improves the functionality and automation of the factory [12]. With wireless technology, sensors can be attached to rotating or vibrating motors, enabling accurate data collection from dynamic environments, such as measuring the frequency of rotating turbines. In addition, self-driving vehicles, robots, and even people can move without any restrictions or spatial limitations while staying connected to the network, thereby enhancing productivity, collaboration, and enabling new use cases.

Despite their benefits, wireless technologies were historically underutilized in industrial networks, primarily due to con-

cerns about higher latency. However, 5G is promising to fulfill the industry’s requirements for real-time operation and low latency, leading to a shift in perception and adoption of wireless solutions in industrial settings.

2.3. 5G Networks

5G, the latest mobile network generation, was designed for three key use cases, including *enhanced mobile broadband (eMBB)*, *Ultra-Reliable Low Latency communications (URLLC)*, and *massive Machine-Type Communications (mMTC)*, catering to the demands of end-users and emerging technologies such as the IIoT. While eMBB achieves speeds up to 20 Gbps, URLLC ensures communication with less than 1 ms latency, and mMTC connects 1 million devices per km², crucial for IIoT and Industry 4.0. Similar to previous mobile network generations and as illustrated in Figure 1, 5G comprises three components; the *User Equipment (UE)*, the *Radio Access Network (RAN)*, and a *5G Core Network (5GC)* [23]. While 5G can integrate into the ICS anywhere, the figure presents a typical scenario where 5G serves as the communication infrastructure between control and field level.

The UE, typically a mobile device with a SIM card, accesses the 5GC, a set of interconnected Network Functions (NF), and its services. The RAN is a collection of one or more *Next Generation Node B (gNB)* responsible for establishing wireless connectivity with the UE while maintaining a physical link to the 5GC. In Figure 1 RAN and gNB are equivalent as the RAN is consisted of a single gNB.

These components exchange *Control Plane (CP)* and *User Plane (UP)* data, where the former manages the connection, and the later handles actual user data, e.g., the industrial data. The UE initiate connections and transmits data to the RAN which oversees various functions, including resource allocation and forwarding CP and UP data to the *Authentication and Mobility Function (AMF)* and the *User Plane Function (UPF)*, respectively. The AMF collaborates with other 5GC functions to govern the UE connection, overseeing authentication, mobility, among other functionalities. The UPF routes user data, typically to the Internet. Security controls for CP data exist between the UE and the AMF, while for UP data, they are implemented between the UE and the RAN.

5G introduces numerous novel technologies such as *Network Slicing*, which enables the deployment of multiple network instances over the same hardware with dedicated resources, and *Mobile Edge Computing (MEC)*, which enables the placement of services/resources closer to the end-user to reduce latency. These advancements, alongside others, make 5G well-suited for industrial settings, offering benefits like enhanced reliability, lower latency, and increased bandwidth to support the increasingly demanding requirements of industrial applications [24].

2.4. 5G in Industrial Networks

The capabilities of 5G position it as a strong candidate for industrial applications. In the following, we investigate the main reasons behind 5G’s suitability for industry, the benefits it

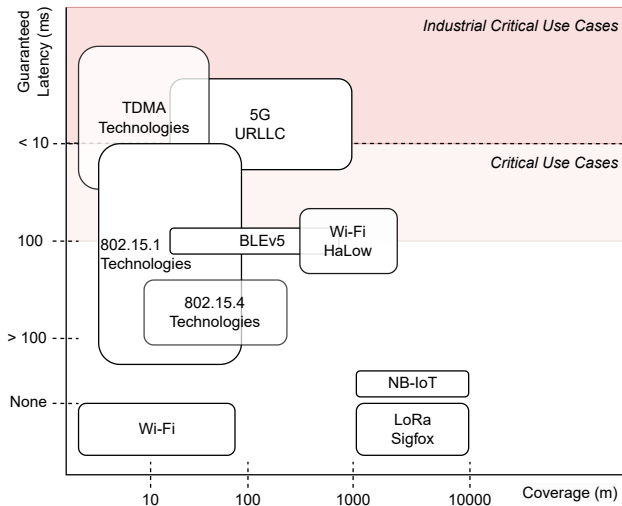

Figure 2: **Guaranteed latency comparison between different wireless technologies:** 5G is the only wireless technology able to meet industries demand without sacrificing range or bandwidth (adapted from [25]).

brings in terms of automation, optimization, flexibility, as well as scalability, and explore prominent potential use cases.

Benefits of 5G for Industrial Networks. As highlighted by Figure 2, 5G URLLC is the sole wireless technology suitable for industrial usage. Previous mobile wireless technologies, such as LTE, provided high bandwidth but suffered from significant latency. Similarly, other protocols, such as Wi-Fi, despite their lower energy consumption, are also prone to higher latency [26]. While Time Division Multiple Access (TDMA) based protocols, such as Wireless Networks for Industrial Automation–Factory Automation (WIA-FA), can compete with 5G URLLC in terms of latency, they usually offer lower speeds, reduced coverage, and capacity [27, 28]. Moreover, 5G is the first wireless network to fully support TSN [29], an IEEE standard ensuring predictable communication in traditional Ethernet networks through synchronization, redundant communication, and time-aware Quality of Service (QoS) [30, 31]. While Wi-Fi 6 offers partial TSN support and not all vendors provide it, standardization to fully support TSN is underway [32]. TSN’s industry-wide adoption is driven by its capacity to transform less reliable Ethernet networks into deterministic, low-latency systems. Consequently, 5G stands as the exclusive wireless technology meeting this demand. In addition, 5G offers additional significant benefits, such as *increased security* (analyzed in Section 3) and a *sub-meter* positioning system that enhances asset tracking and streamlined process optimization. Finally, 5G also offers the inherent benefits of wireless technology, such as enhanced automation and mobility as detailed in Section 2.2.

Exemplary Use Cases. As a novel technology, 5G offers a wide range of applications in industrial networks, enabling the development of new use cases [17]. One significant advantage of 5G is the mobility it brings to previously stationary or limited-movement components, overcoming cabling constraints. UEs can now be integrated into industrial components such as sensors and robots, enabling automation and/or improve-

ment of multiple tasks on the production line. Examples include *Warehouse Automation*, where autonomous robots transport and organize goods, and *Motion Control*, which involves a closed control loop regulating moving parts in a physical process. The latter task can be particularly challenging in non-wireless scenarios [16]. Another significant aspect of 5G that enables new use cases is its low latency capabilities. Traditionally, due to the importance of real-time monitoring and control for safety, HMI systems connected by wires were positioned within the shop floor, limiting flexibility and increasing costs. However, with the adoption of 5G, devices on the shop floor can now transmit data in real-time to systems located outside of the industrial premises, enabling *Remote monitoring and Control* [24]. Moreover, *Machinery Maintenance*, which typically requires on-site specialists, benefits from 5G’s real-time capabilities. Remote specialists can guide on-site personnel through live data transmission using camera sensors, reducing costs and response time. Lastly, the innovations of 5G further enable new use cases. A major example here is network slicing, which enables effective *Network Segmentation* by dividing the network into slices with isolated traffic and distinct security configurations, thereby reducing the need for additional hardware for Virtual Local Area Networks (VLANs) such as routers and switches, currently used in industrial networks for segmentation purposes.

Summary: 5G stands out as the only wireless technology that not only satisfies the industry’s ever-growing demands but also enables innovative use cases and introduces tools that bolster functionality, automation, and cost efficiency. However, the introduction of numerous new components and technologies with 5G expands the industrial network’s attack surface. Thus, ensuring the secure deployment and operation of the 5G network is paramount to safely realizing its benefits.

3. State of the Art: Secure Usage of 5G

The 5G specifications enable the deployment of *non-public 5G* networks (also known as *Private 5G*) owned and managed by individual companies, often industrial, allowing them to leverage the advantages of 5G without impacting public/commercial networks. However, the complexity inherent in the 5G specifications poses challenges for secure integration. Specification is often complicated and ambiguous, dispersed across multiple sources, and many of its controls are optional to utilize/implement. To facilitate a smoother and secure deployment of a 5G network in an industrial environment, we present the state-of-the-art in 5G secure integration, including deployment options that focus on the physical setup of the network (Section 3.1), and configuration techniques, which involve the customization of network settings in terms of security (Section 3.2), thereby focusing on the specifics of using 5G in industrial networks.

3.1. Secure Deployment

The deployment of a 5G system is a crucial step, especially concerning security. This section explores different deployment options for private 5G networks, including standalone (SA) versus non-standalone (NSA) configurations (Section 3.1.1), as well as various private 5G topologies (Section 3.1.2). Determining the optimal deployment for security can be challenging for industrial companies without previous experience in cellular networking, often leading cost to take precedence if potential risks associated with the more *cost-efficient* deployments are not fully understood. The section also delves into the security considerations associated with these deployment options.

3.1.1. SA and NSA

3GPP explicitly defines two deployment options for a 5G network: SA and NSA deployments. The SA deployment, as detailed in Section 2.3, is considered “*the true*” next generation of mobile networks. It incorporates all the innovations and improvements outlined in the 5G specification. On the other hand, the NSA deployment utilizes a 4G core network, also known as Evolved Packet Core (EPC), instead of a 5GC, and a RAN consists of one or more evolved Node B (eNB; the 4G equivalent of gNB) and one or more gNB [9]. The UE is connected simultaneously to both a gNB and an eNB, both of which are connected to the 4G core. Here, the eNB is responsible for handling the CP data of the connection, while the gNB handles the UP data. The purpose of this deployment was to enable a smooth rollout of 5G, allowing end-users to already use the high bandwidth offered by 5G in early stages. In this paper, when we refer to 5G, we imply the SA deployment.

Regarding security, SA deployments incorporate all the security enhancements provided by 5G. In contrast, NSA relies on the 4G security specifications, which are notably inferior to those of 5G [9]. The most significant security improvements of SA over NSA are outlined in Table 1. To begin with, in a 5G SA network, all subscriber credentials are sent encrypted, and only the 5GC can decrypt them. This setup effectively prevents attacks related to user privacy, such as tracking their location (more information in Section 3.2.4). Moreover, integrity and encryption are mandatory features to support for the UP, as opposed to being optional as in the case of 5G NSA. In industrial settings where the UP carries all industrial traffic, these features are crucial for preventing attacks like data tampering and false data injection [33]. Another crucial feature of 5G SA is the encryption of the initial Non-Access Stratum (NAS) message, which is the protocol responsible for CP signalling between the UE and the AMF. This serves as defensive mechanism against DoS attacks towards the UE [34]. Furthermore, in a 5G NSA network, the UE radio capabilities are sent unprotected from the UE to the RAN. As the name suggests, this message contains critical information about the UE’s radio capabilities, such as supported frequencies. Tampering with this information can lead to undesirable outcomes, notably battery drain, which can be catastrophic for ICSs with battery-powered sensors [9]. 5G SA counters this by sending this information after the CP security establishment, which means that at least integrity protection will be applied (CP security is discussed in Section 3.2.1).

On top of those benefits, 5G SA provides support for 256-bit cryptographic algorithms for both UP and CP for enhanced security and protection against potential quantum-attackers in the future [35].

Table 1: NSA and SA Security

Security Control	5G NSA	5G SA
Subscriber Identifiers	No protection	Send encrypted
UP Security	Option. support	Mandat. support
Initial NAS Message	No protection	Send encrypted
UE Radio Capabilities	No protection	Send protected
Crypto. Algorithms	128-bits	256-bits support

However, security is not the only concern with NSA deployments in an industrial context. NSA fails to meet industry demands for low latency and real-time operation, particularly in the context of URLLC, as it relies on an EPC that was not designed with low latency in mind. Additionally, it lacks essential functionalities for industrial networks, such as TSN support and network slicing. Even-though 5G NSA could be utilized by industrial companies already possessing a 4G network and intending to transition gradually to a 5G network in the future, companies should not rely on it due to its weaker security and performance. To summarize, 5G SA is the true fifth generation of mobile networks, able to meet the demands for real time operation and increased security.

3.1.2. Private 5G Topology Options

The 5G specification [23] defines two types of 5G networks: public 5G networks operated by Mobile Network Operators (MNO) and non-public (or private) 5G networks managed by private organizations or corporations. While public 5G networks are deployed to serve commercial customers and are typically configured to meet the requirements of average end-users for eMBB, private networks can be tailored to address the specific needs of industries, usually focusing on URLLC and mMTC. Various deployment models exist for private 5G networks, each offering distinct advantages and benefits over the others. Deployment methods include choosing between licensed, unlicensed, or shared spectrum, as well as incorporating ownership and management of the components between the enterprise and a MNO [11]. In the following, we evaluate the four deployment options for private 5G deployments identified by 5G-ACIA [10] as depicted in Figure 3, and we summarise our comparison in Figure 4.

As illustrated in Figure 3, the *Standalone* (distinct from 5G SA) deployment is a scenario in which the industrial company deploys and controls all components of its private 5G network on its own. In contrast, the *Shared RAN* deployment involves sharing the RAN with the MNO. The RAN is connected to both the MNO’s and the industrial company’s 5GCs, but it is usually managed by the MNO. Similarly, in the *Shared RAN & CP* deployment, the two entities additionally also share the CP. Lastly, in the *Shared* deployment, the industrial company utilizes the MNO’s existing infrastructure, where the MNO handles both

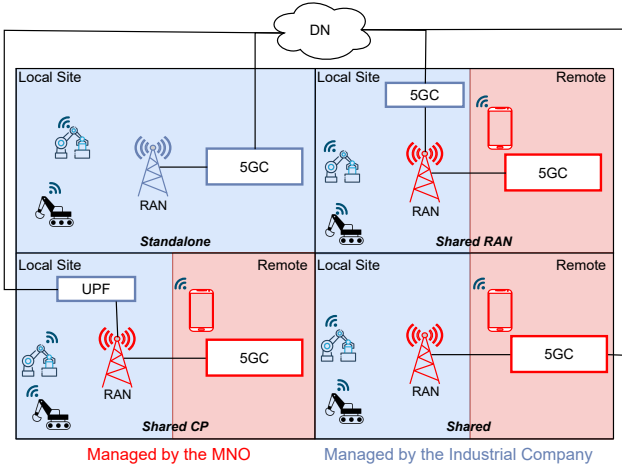

Figure 3: **The different Private 5G deployment models:** Besides standalone deployment, where the industrial company owns and manages the entire network, other deployment scenarios involve sharing parts with MNOs, including elements such as the RAN and parts of/the entire 5GC. This sharing is facilitated by Network Slicing.

RAN and 5GC, achieved through an agreement for a dedicated network slice [36].

Each of these deployments offers unique benefits, but only a standalone deployment holds the potential for increased security levels and high performance. With full control over every component, an industrial company can enforce comprehensive security controls, such as encryption protocols, segmentation techniques, and access control, on every 5G component. Additionally, the dedicated resources ensure that the entirety of the resources will be available in case of need [37]. The Shared RAN deployment, involving a RAN sliced in two or more slices, could theoretically provide similar performance and security. However, by sharing components such as the RAN, the risk of unauthorized access to industrial networks is increased. As UP security controls, are only between the UE and RAN, the encryption keys are stored within the RAN. A malicious MNO that manages the RAN and has physical access to it, could potentially gain access to UP encryption keys [38]. Furthermore, successfully attacks on one slice with inferior security controls, could potentially affect the other slices e.g., by draining all the available resources, if strong isolation controls are not in place.

The remaining two deployments are unsuited for industrial usage as they face performance issues, i.e., they do not meet industrial requirements such as low latency and real-time operation. Specifically, the Shared deployment encounters performance challenges due to the remote placement of the 5GC (including the UPF) and is thus not suitable for industrial usage as it might not meet low latency requirements. On the other hand, the Shared CP deployment’s remote placement of the 5GC CP should not be an issue for time-critical applications. However, in certain cases with a significant amount of CP traffic, such as in mMTC scenarios, slicing the CP of 5GC it may still become problematic [11]. For example, congestion in the 5GC can occur due to multiple authentication requests, such as in an IIoT

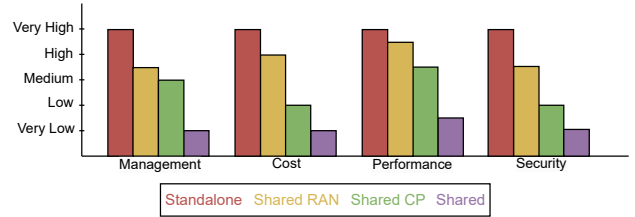

Figure 4: **Capabilities of the different private 5G deployments:** The capabilities of each deployment vary in terms of management, cost, performance, and security. Generally, the more expensive the deployment, the easier it is to manage and ensure high performance and security.

scenario with multiple sensors. As the 5G network authenticates each device before allowing access to a specific slice and its dedicated resources, authentication requests from multiple slices (including the industrial company slice, the MNO slice, and other slices that the MNO may host) are handled by the same underlying resources. This could throttle resources and introduce significant latency in the authentication of industrial devices, as authentication is one of the most expensive operations in 5G [39].

In addition, both of these deployments are significantly less secure than the other deployments: Having a remote 5GC means that sensitive data, such as authentication and/or user data, is being sent, processed, and stored outside of the company’s premises. This increases the risk for unauthorized access, tampering, and other security concerns [40].

While a complete local deployment of the 5G network is the preferred option for enhancing security in industrial settings, it is essential to indicate that the effectiveness of the Standalone deployment heavily relies on “the optimal”, with regards to security, configuration of network settings. In the absence of such configuration, the security potentials of a Standalone deployment are compromised.

3.2. Secure Configuration

5G offers a range of security enhancements compared to previous mobile network generations, making it increasingly appealing for use in industrial networks. However, many of the additional security controls are optional to implement. In the following, we filter out and explain optional controls deemed important for industrial networks [13, 14].

3.2.1. Control Plane and User Plane Data Security

In a 5G system, data is split between two planes: Control Plane and User Plane (cf. Sec. 2.3). CP data is exchanged between network components to manage various aspects of communication, e.g., call setup, handovers, network registration, and resource allocation. UP is the actual data that end-users send.

The 5G specification outlines a set of four pairs of cryptographic schemes for encryption and integrity protection for UP and CP data [41]. These schemes are based on different cryptographic algorithms: *NULL*, *SNOW*, *AES*, and *ZUC*. It is important to note that the *NULL* scheme offers no protection

at all, and if used, data is transmitted as plaintext and without any integrity protection. In addition, according to the specification, implementing these schemes is mandatory for both planes, with the exception of the pair based on ZUC, which is optional. While support for integrity and encryption is mandatory for both planes, their utilization is optional and at the discretion of the operator [13]. In other words, the operator may choose to utilize the NULL scheme. However, an exception lies in the mandatory integrity protection for CP data, where the NULL scheme is not permitted (with certain exceptions such as emergency calls). In industrial settings, prioritizing the use of optional security controls for both planes—avoiding the NULL scheme for encryption or integrity protection—is crucial due to various concerns associated with each plane.

To begin with, it is noteworthy that industrial protocols rarely operate over security protocols such as TLS or IPSec [42]. Consequently, industrial data often remain unprotected over the underlying network, in our case, the UP of 5G. Even if a security protocol is used, it is usually one of the previously mentioned protocols on the upper layers of the protocol stack, which do not offer any protection to TSN data, as TSN operates at the data link layer. Thus, protection needs to be applied either at the data link layer or the physical layer. Therefore, as TSN data are also being encapsulated in the UP of 5G, tampering attacks on the synchronization data may remain feasible and threatening with a complete loss of availability, even if TLS or IPSec is used. To address this, optional 5G security controls should be enforced to provide protection to the UP data. In an industrial setting, the integrity of the UP data is deemed as the most important security control, as without it, an attacker could intercept, inject, and manipulate industrial data (such as controller commands and sensor readings) or synchronization data, causing a system malfunction or a complete loss of availability, and potentially threatening human lives. While encryption is also important, it is less critical for industrial networks. Encryption of the UP safeguards against exposing the system’s information to unauthorized parties but does not directly threaten the safety, e.g., of the personnel. Similarly, encryption of the CP will safeguard the data from unauthorized parties, ensuring that an attacker is not able to monitor the network and extract information about the 5G network and identify flows/vulnerabilities (such as the AMF accepting authentication requests with the NULL scheme for integrity protection of the CP [43]).

In 5G networks, the presence of the wireless link (i.e., the Uu interface) between the UE and RAN further emphasizes the need for utilizing encryption and integrity protection controls, as radio waves propagating over the air are much harder to control than bits-on-the-wire. Anyone with cheap radio equipment (also known as sniffers) could potentially eavesdrop on CP/UP data [44]. While it could be argued that manipulating over-the-air data is much harder than eavesdropping and requires extensive knowledge and tools, it is still possible, as proven by Rupprecht et al.[45], who successfully manipulated UP in 4G networks where UP integrity protection does not exist, by utilizing Software-Defined Radios (SDRs) and open-source software. Consequently, integrity protection and encryption are important for both CP and UP, and should thus be enabled.

3.2.2. RAN Internal Interfaces & N2/N3 Security

Besides the wireless interface between UE and RAN, multiple interfaces in the 5G architecture require support for security mechanisms, yet their usage is optional. Regarding the RAN internal interfaces (green section in Figure 1), all interfaces should support the IPSec ESP protocol for confidentiality, integrity, and replay protection, along with IKEv2 for certificate-based authentication [41]. However, the specification mandates their usage only for the F1-C and E1 interfaces, handling sensitive control and management data. The application of these protocols to the F1-U interface, responsible for transmitting UP data, remains optional [13].

Similarly, the N2 and N3 interfaces, responsible for transmitting CP and UP between the RAN and the 5GC respectively, must support IPSec with IKEv2, and in the case of N2 also DTLS. However, the decision to actually configure the 5G system to utilize them is left to the operator once more [13, 41]. While CP data benefits from mandatory integrity protection between the UE and the AMF, safeguarding it over the N2 interface, UP data do not benefit from any security controls of the UP. Even with the optional UP integrity protection and encryption in place, UP data remain exposed over the N3, as security controls for UP only protect the data between the UE and RAN over the Uu interface. Hence, leveraging all available optional security protocols is crucial to ensure encryption and integrity protection to the UP traffic over N3.

3.2.3. Core Network Security

After examining the RAN internal interfaces and the interfaces connecting it to the 5GC, we proceed to examine the 5GC itself. For the core network, 5G introduces a Service-Based Architecture (SBA) comprising interconnected Network Functions (NFs) that cooperate with each other to handle various CP and UP functions. These functions expose their services, through RESTful APIs.

A key benefit of this architecture is its modularity and ability to integrate customized, on-demand additional NFs to the 5GC. These NFs can potentially be exposed to external parties to expand the services of the 5GC [46]. However, as these services can be exposed to external entities and delivered by third parties, the risk of a malicious or a compromised NF is substantial. In such a case, the compromised/malicious NF could potentially disrupt operation of the 5G system or exfiltrate sensitive data. Hence, prioritizing security controls like authentication, authorization, and end-to-end security across SBA interfaces is crucial.

Authentication prevents the deployment of unauthenticated NFs by verifying their identity, while authorization ensures that only authorized NFs can access certain services and data based on predefined permissions. End-to-end security safeguards against data tampering and eavesdropping. To meet these security requirements, 3GPP mandates the implementation of TLS for authentication and end-to-end security, coupled with OAuth 2.0 for authorization [41]. While the use of TLS (or alternative controls if deemed necessary by the operator [13]) for establishing encryption, integrity protection for both CP and UP data, and entity authentication over the SBA interfaces is mandatory, the

use of OAuth is not. The OAuth authorization framework leverages tokens to grant different access levels between consumer NFs and service NF providers, thereby preventing unauthorized access to critical functions, such as retrieving user identifiers or setting network configurations and policies. Unauthorized access to NF services can have numerous consequences, ranging from extracting sensitive data to a complete loss of availability for the ICS e.g., by de-registering other NFs such as the AMF from the 5GC [47].

Consequently, to ensure the security of the 5GC, both TLS and OAuth 2.0 should be used. Any alternative to TLS should be well-justified, offer at least the same security controls, and still adhere to latest security standards.

3.2.4. Other Optional Security Controls

Assuming that an industrial company employs all optional controls outlined in the preceding sections, we could contend that both CP and UP are safeguarded across every interface, rendering the architecture as secure as possible. Nevertheless there are still parts of the communication that remain unprotected, and other additional non-compulsory security controls that will further enhance the security of the industrial network if utilised.

SUPI Encryption. As briefly mentioned in Section 3.1.1, the subscriber's credentials in a 5G network are sent encrypted for user authentication, preventing localization, linkability, and tracking attacks. These credentials include the Subscriber Permanent Identifier (SUPI), which is the unique identifier assigned to each UE for identification. In previous mobile network generations, such as LTE (where it is known as IMSI), IMSI catchers posed a significant threat by allowing the tracking of individuals since the identifier was transmitted in plain text [48, 49]. To mitigate this risk in 5G, SUPI encryption was implemented, but only as an optional control.

In the context of industrial 5G networks, a linkability attack occurs when an attacker is able to correlate different sessions or activities back to the same UE. This allows the attacker to identify patterns in industrial communication and gain crucial information from traffic (data or metadata in the case of encrypted UP). For example, by analyzing the traffic, an attacker may deduce which UE corresponds to a controller or sensor and attempt to interfere with the connection. Although linkability attacks have been proven possible even with SUPI encryption, these attacks do not pose as significant a threat as IMSI catchers [50].

Similarly, tracking attacks involve monitoring and following the movements and activities of an industrial machine or person over time. In industrial 5G networks, an attacker may try to ascertain the presence and location of specific employees or critical industrial devices in a factory, risking unauthorized access to data or processes. For example, tracking the location of security personnel or autonomous, self-driving robots in the factory could enable an attacker to illegally enter the premises or tamper with industrial robots. SUPI encryption helps to protect against tracking attacks by ensuring that the SUPI is not transmitted in plaintext, making it more difficult for attackers to track UE movements.

Authentication. 5G supports multiple authentication levels: (a) *Primary authentication* for mutual authentication between the UE towards the 5GC ([41] Clause 6.1), (b) *Secondary authentication* to authenticate the UE to external networks ([41] Clause 11.1), and (c) *Network slice-specific authentication* for authentication between a UE and a network slice ([41] Clause 16.3). Primary authentication can use 5G-AKA, EAP-AKA, or other EAP-based authentication algorithms such as EAP-TLS [51], and is the only mandatory authentication procedure. Secondary and slice-specific authentication utilise the EAP framework defined in RFC 3748 [52] and are both optional.

The primary authentication takes place during the initial access of the UE to the 5GC system, and can be invoked periodically for re-authentication of the UE. As this procedure is mandatory, the 5G system ensures that only authenticated devices can access the network. However, employing the secondary and the slice-specific authentication will further enhance the security of the system, especially in certain use cases in industrial networks. As mentioned before, secondary authentication can be employed to authenticate the UE to external networks. After the primary authentication, secondary authentication can be invoked with another set of credentials different from the primary authentication, such as digital certificates or usernames and passwords, depending on the EAP-based authentication method. This can be extremely useful for an industrial company to relegate access to external resources, such as cloud-based services or data stored in the intranet. Similarly, slice-specific authentication can be used after primary authentication to authenticate the UE to a specific network slice with a different set of credentials. This authentication is particularly important when network slicing is used in industrial networks, such as for segmentation purposes. This ensures that only authorized UEs can access resources dedicated to a specific slice, thereby mitigating risks such as unauthorized access to services belonging to a specific slice, resource draining and performance degradation.

Further Optional Controls. In the previous sections, we analyzed the most critical optional security controls for the industrial networks. Other optional security controls exist, such as gNB certificates and enrollment or implementation of 256-bit algorithms, which can be utilized to further enhance security, beyond from what we already proposed. More information on these controls can be found in [13, 14].

Summary: 5G offers many enhancements in terms of security compared to previous generations of mobile networks, which can be utilized to enhance and even retrofit security in industrial networks. Such enhancements are the multi-authentication schemes and the protection of UP data. However, 5G's complicated specifications, which include numerous optional controls and various deployments of private 5G networks, could make it challenging for industrial companies with no previous experience or expertise with mobile networks, to deploy 5G securely.

4. Opportunities

Building on the foundational security improvements 5G provides, we believe that its novel approaches and tools hold significant potential to further enhance the security of industrial networks. To support further research, in this section, we identify several ways in which 5G's innovative tools and modular design can be utilized to enhance security. Features such as enhanced segmentation as well as real-time detection and prevention of attacks at the network edge could be realised with 5G, offering promising avenues for strengthening the overall security of the industrial network.

4.1. Effortless Network Segmentation

Segmentation in industrial networks is a commonly employed technique to divide the network into smaller segments [1]. This allows for better control of flows between different segments and helps mitigate the risks of attacks on one segment spreading throughout the network. Traditional segmentation techniques include VLANs, firewalls, as well as physical separation.

5G network slicing (cf. Section 2.4) has the capability to replace or work in parallel with traditional network segmentation techniques, enhancing security and automation in industrial networks simultaneously. Achieving a sliced 5G network involves segmenting the RAN and 5GC for the deployment of end-to-end isolated slices over the same hardware. Each slice can then have unique requirements in terms of resources, security controls, and QoS policies. Network slicing can be utilized to separate traditionally segmented networks, such as the network for employees with access to the Internet, and the ICS network with strict performance and security requirements, by deploying two different slices. However, with network slicing, we could potentially realise novel segmentation techniques such as nano-segmentation [53]. Nano-segmentation is achieved by enabling every node in the network to verify that each packet that is processed, (a) is a part of a white-listed flow and (b) is originated from an authorised host. In this way, a per-device segmentation is enabled.

In a 5G industrial system, we could potentially achieve nano-segmentation by leveraging slicing-based segmentation and refining the approach through reducing the size of each network slice, potentially down to a single UE per slice. This approach is depicted in Figure 5 where the industrial network, consisting of three components, is divided into three slices, one for each component. By doing so, each slice becomes a highly isolated environment, ensuring that each UE operates within its own dedicated and secure virtual network. This granular segmentation significantly mitigates the risk of lateral movement by malicious actors within the network. Slice-specific authentication mechanisms can be utilized to verify the identity of the UE within each slice. In this way, each network node can verify that packets were generated by an authorized host UE, as only that UE has access to the corresponding slice. Furthermore, NFs can be implemented at various levels of the network, including the RAN, 5GC, MEC nodes, and SDN Controllers

(cf. Section 5.2), to enforce allowlisting policies. These policies ensure that only authorized communications are permitted between slices (and therefore between industrial devices), thereby maintaining compliance with the overall network security framework.

Furthermore, a slice-based segmented network could further enhance automation and security as it will allow slices to allocate/deallocate their resources based on their needs and, in the event of an attack, the 5G system could potentially denylist specific slices to quarantine affected devices before any spread occurs within a the network [54].

4.2. Reduced Downtime and Enhanced Availability

Availability is the most important security requirement of an ICS, as any interruption may cause widespread disruptions and potentially threaten human lives. For example, in the case of power grid systems, an availability issue could result in large-scale power outages, affecting hospitals, transportation systems, and emergency services [55]. Similarly, in industrial manufacturing, an interruption could halt production lines, leading to significant economic losses and potential safety hazards for workers. The virtualised architecture of 5G could be utilised to enhance the availability of an ICS and mitigate the downtime of the system in the event of attacks or security updates.

Virtualization is a fundamental process in 5G, involving the software-based transformation of a system. Two key examples of virtualization are *Network Function Virtualization (NFV)* and *Software Defined Networks (SDN)*, which play crucial roles as enablers of network slicing [56]. NFV involves the virtualization of specific network functions, such as the 5GC or the RAN. On the other hand, SDN focuses on virtualising the network management, including routing functionalities, detached from the underlying hardware. These softwarised function, are also known as Virtual Network Functions (VNF). Virtualization opens the door to numerous security enhancements that could potentially reduce the downtime of the system in case of attacks or updates.

Firstly, its programmable nature enables dynamic adjustments of security mechanisms, such as logging, authentication, and verification [57]. In addition, update and patch management are simplified, as new patched versions of specific functions can be deployed in parallel with existing ones. This is crucial for ICS, as it cannot afford frequent disruptions to its operations for security patches and updates. This is one of the major reasons why industrial equipment is often not up-to-date.

Secondly, virtualization could potentially become a major security response control to attacks. Techniques such as Virtual Machine (VM) migration could be employed in scenarios where a part of the system is compromised, or a specific segment of the underlying network is under a DoS attack, to mitigate the effects and reduce or potentially avoid downtime [58]. Furthermore, as specialised hardware is no longer required, it is easier to maintain real-time updated, standby backup copies, which can be easily deployed to take over crucial functionalities, in case of a successful attack.

Lastly, virtualization, as a well-studied technology, already benefits from a multitude of existing research which examines

techniques to mitigate and prevent DoS attacks [59, 58, 60] and to improve intrusion detection [61, 62]. However, more research regarding enhancing availability is needed under the 5G concept and within ICS. In the following section, we provide an example of such an approach, specifically utilising the MEC to push security-related NFs to the edge of the network.

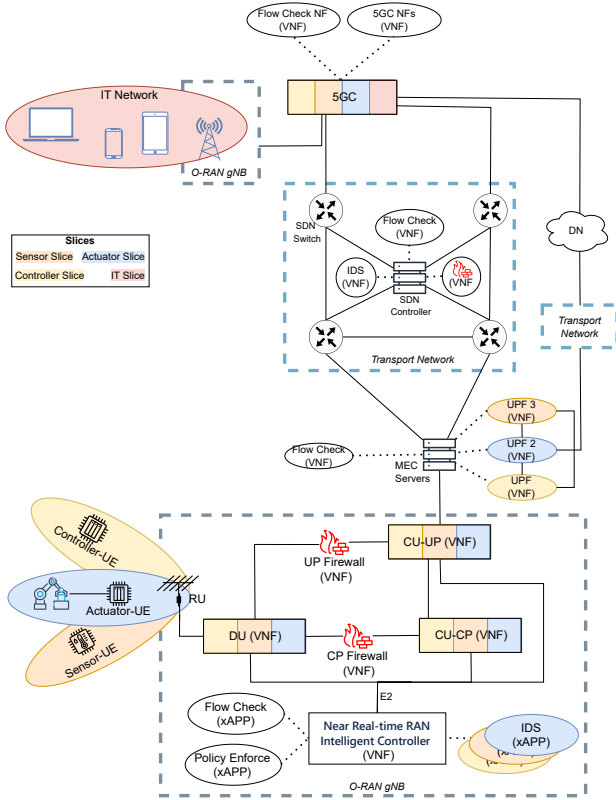

Figure 5: An exemplary nano-segmented, sliced 5G network with distributed security controls: The 5G infrastructure serves four different slices and the color of each component indicates the slice it belongs. The IT network of an industrial company has a dedicated slice, while the industrial network uses nano-segmentation, with each industrial UE operating within its own slice. Every node in the 5G network verifies the validity of the flows: the RAN via the xAPP and the 5GC/MEC/SDN-controller via a custom NF. Security controls, such as firewalls and IDSs, are distributed throughout the architecture as VNFs running over the same hardware or as dedicated xApps.

4.3. Distributed Security at the Edge

One important innovation of 5G is the promotion of MEC. This approach to the distribution of resources supports relocating computation units and data storage closer to end-users, serving as a key component for enabling URLLC deployments in 5G. An example is the placement of the UPF closer to the end-user, either on MEC servers close to the RAN or even within the RAN.

In-RAN deployments of NFs could benefit from and potentially be realized by the O-RAN architecture, an extension of the 5G RAN architecture. The 5G RAN, consists of components such as the Central Unit-User Plane (CU-UP) and Central Unit-Control Plane (CU-CP), which handle UP and CP data, respectively, and the Distributed Unit (DU), which manages the

radio resources and executes lower-layer protocols. O-RAN introduces additional components like the near-real-time RAN Intelligent Controller (RIC), which allows for the dynamic deployment of smart applications (also known as *xAPPs*) directly within the RAN. These *xAPPs* can enhance network performance, security, and flexibility by providing real-time analytics and control capabilities over the E2 interface [63]

These applications can monitor various aspects of RAN performance, including traffic patterns, latency, and throughput. In addition to monitoring, they can apply real-time control mechanisms to enhance RAN functionality. This may involve dynamic resource allocation, prioritization of certain traffic types, load balancing, or even dropping connections that are deemed non-critical or malicious.

Combining MEC with the modular architecture of 5G, which splits the 5GC and RAN into multiple components, an industrial company could establish a distributed security scheme. This scheme would enforce individually tailored security controls on each network component at multiple levels, particularly at the edge of the network.

This could enable on-time detection and response to attacks before affecting critical components and the spread of lateral movement. For example, within the RAN, different firewalls could be deployed on the CU-UP and CU-CP—components of the RAN that handle UP and CP data, respectively—to establish distinct security policies for the two planes.

Additionally, *Intrusion Detection Systems (IDS)* and *Firewalls* could be implemented as *xAPPs* in the RAN to detect attacks in near-real-time [64, 65, 66]. IDS and Firewalls are commonplace in industrial settings due to their ability to retrofit security in insecure systems [1]. They take advantage of the deterministic traffic patterns typical in ICS environments, enabling them to effectively identify anomalies and potential threats [67]. The 5G O-RAN architecture facilitates easy expansion of these systems. For example, upon detection of an intrusion, an intrusion detection *xAPP* could send commands to the RAN components (CU and DU) in near-real-time to drop the connection, thus mitigating the impact of the attack.

Furthermore, *Honeypots* [68], systems that simulate the ICS to attract attacks towards themselves instead of the real ICS, could be deployed alongside the UPF in the MEC servers. This not only serves to divert and analyze potential threats but also provides an additional layer of protection for the legitimate ICS.

Summary: 5G has the potential to further improve the security of ICS. Its novel technologies and approaches, can complement and enhance traditional security controls. Network segmentation becomes effortless with network slicing, and critical functions such as IDS and can be deployed instantly anywhere in the network. The distribution of these security controls throughout the ICS, placed and configured appropriately for each component, enables prevention/detection of attacks at the edge of the network enhancing availability.

5. Challenges

Despite its enhanced security and the further opportunities it holds, 5G does not come without security challenges. The enormous complexity and new technologies introduced by 5G significantly expand the attack surface of ICS. Many concerns are present, particularly regarding two critical aspects for the industry: availability and real-time operation. In the following, we detail these concerns, highlighting the need for further research to address them and pointing out potential directions for future work.

5.1. Jamming Attacks on the Wireless Interface

While 5G offers significant security advantages, it is not immune to physical layer attacks. *Jamming*, where attackers disrupt communication by causing interference in the wireless channel, remains a threat. Although 5G boasts improved resilience compared to LTE [69], a sufficiently powerful jammer can still cause significant disruption. For industrial networks, jamming poses a critical risk. A successful attack could completely sever communication between UE and RAN, effectively rendering the system unavailable [70]. Since complete prevention is not feasible, industrial operators must focus on detection and mitigation. Fortunately, 5G offers built-in mitigation techniques. Redundancy communication channels for UP data can be established through additional gNBs and UPFs operating on different frequencies.

However, research in this area continues. Works like [71, 72] propose further countermeasures such as frequency hopping and dynamic scheduling to strengthen 5G's resilience against jamming attacks. Frequency hopping involves changing the carrier frequency of the transmitted signal according to a pseudorandom sequence, making it difficult for jammers to target a specific frequency. Dynamic scheduling adjusts the allocation of resources according to the current network conditions. By doing so, the system can avoid predictable patterns of transmissions, that jammers might exploit. In addition, other countermeasures such as Direct Sequence Spread Spectrum (DSSS), which spreads the information signal over a bandwidth larger than required, hold the potential to provide significant protection against jamming attacks. DSSS spreads the signal by multiplying it with a pseudorandom noise sequence, making the transmitted signal to look as noise to unauthorized receivers and reducing the impact of narrowband jamming. While DSSS might be unsuitable for commercial networks that aim to maximize bandwidth capacity, it could be applied to industrial networks that usually do not require as much bandwidth.

Complementing approaches to what is already proposed, could be the integration of an IDS tailored for wireless communications. As mentioned in Section 4.3, IDS are often deployed in industrial networks to retrofit security, by alerting the operators about potential ongoing attacks. As these IDS often take into consideration deterministic characteristics of the industrial traffic, such as the inter-arrival time of packets containing industrial data [73], they could also potentially identify jamming attacks. Jamming attacks will impact industrial traffic, for example, by increasing the drop rate, latency, and inter-arrival

times. In addition, an IDS system in the form of an xAPP could also utilize RAN or UE reports [66], such as the Signal to Noise Ratio (SNR) metrics produced by the gNB, to identify potential jammers in the area. Jammers can cause significant degradation in the SNR of a 5G cell due to radio wave interference. However, further research is needed to determine whether traditional IDS methods, such as the aforementioned inter-arrival time IDS, work effectively in wireless environments and detect jamming. Additionally, research should explore how modern approaches, such as RAN xAPPs, can enhance the detection of jamming attacks.

5.2. Expanded Attack Surface with regards to Availability

The vantage points for an attacker in a virtualized and sliced 5G industrial network are far more numerous than in a traditional industrial network due to the various technologies, tools, and components introduced by 5G. Therefore, despite its potentials discussed in Section 4.2, it is much more effort-demanding to secure the 5G industrial network and ensure its high availability.

To begin with, the generic threats of virtualization also threaten the ICS. The softwareization of network functions introduces various threats associated with software, which can be very difficult to address. Threats to virtualization include software bugs due to improper coding, known vulnerabilities in open-source tools that might have been used, runtime vulnerabilities, and inadequate input sanitation. These vulnerabilities can give attackers opportunities to exploit and gain access to the 5G system [57, 74].

More specifically, in 5G networks, multiple NFs often run over the same hardware, such as for slicing purposes. Depending on the virtualization method used (e.g., VMs, containers), different isolation mechanisms must be established across various levels, from the 5GC and RAN to the transport network and down to storage units and processing resources. These mechanisms are essential for the industrial company to avoid issues such as resource draining and privilege escalation by compromised NFs or slices [75, 76]. Such attacks can lead to a complete loss of availability, emphasizing the critical importance of robust isolation and security measures in industrial network deployments.

In addition, the virtualization of 5G components makes cloud deployment of several non-time-critical NFs, such as the CP, appealing. Although in Section 3.1.2 we argue in favor of local 5G deployments, we cannot ignore the fact that a vast number of companies could choose to host their network in the cloud services of some operators, such as Amazon AWS and Microsoft Azure, in favour of cost savings. However, DDoS attacks, a significant threat that is amplified in the cloud infrastructure exposed to the Internet, render the NFs that run over it vulnerable to a complete loss of availability [77], and therefore the operation of the ICS.

Finally, SDN, which, as explained in Section 4.2, is a virtualization technique for network infrastructure, also poses significant threats to the availability of the ICS. This is because, in SDN, the management of the network is centralized in a single unit called the SDN controller.

The SDN controller is a programmable component that, like the O-RAN architecture, can host applications for various network functions and optimizations. Its primary responsibility, is establish end-to-end connections by installing flows in the underlying transport network (switches). Therefore, it is often considered a single point of failure. If an attacker successfully deploys a DoS attack on the controller or takes control of it, they could render the entire transport network non-functional [78].

All of the previously mentioned tools, are vantage points where an attacker can compromise the availability of a system have something in common: a significant amount of research has been dedicated to studying these approaches and their security. However, their utilization under the 5G concept remains unclear. To address this, several frameworks should be developed for different virtualization methods to enable the secure development of virtualized network functions [79]. Isolation mechanisms should be standardized at every layer and enforced by these frameworks. For cloud deployments, an industrial company should ensure that the cloud operator implements necessary controls for DoS prevention and provides a high availability guarantee through the Service Level Agreement (SLA), a legally binding document for both parties. Security controls that the cloud provider should implement includes traffic filtering (e.g., with firewalls), detection and abortion mechanisms, and mitigation techniques to instantly re-deploy systems that were successfully attacked [80, 58]. Furthermore, SDN deployments that avoid single points of failure should be investigated to ensure they do not introduce additional latency to the flow establishment between transportation nodes and, consequently, to the transmission of critical industrial data [81].

5.3. Performance over Security

In time-critical industrial applications, latency and real-time operation are vital to ensure correct operation and safety [82]. However, cryptographic operations, especially those related to integrity protection, are known to introduce a notable amount of latency to communication [83]. However, as the importance of UP security is important (cf. Section 3.2.1), industrial companies are often required to make a trade-off between low latency and security, typically sacrificing security in favor of performance.

To illustrate this issue, a recent study performed measurement to assess the overhead added by the integrity protection of the UP [84]. The results indicate that even in the low latency configuration of 5G, the additional overhead added to the round-trip time can render UP security unsuitable for industrial applications. As these measurements did not consider any additional protection controls, e.g., securing the N3 interface, further latency increases additional challenge the use of 5G in industrial scenarios. To address this issue, research on lightweight cryptography is a promising candidate. Consequently, more efficient cryptographic algorithms or message authentication code schemes should be studied and adopted in industrial 5G networks. Examples include AES-GCM, a scheme for authenticated encryption that speeds up processing by computing MAC and ciphertext in parallel, and is recommended in

the technical report on URLLC security by 3GPP [85]. Another promising example is BP-MAC [83], which can be utilized for integrity protection and has been demonstrated to be faster than other lightweight integrity protection schemes, particularly for shorter messages, which are often encountered in industrial networks. Finally, as industrial devices often lack the computational power and/or hardware accelerators for traditional cryptographic schemes, or may have limited bandwidth (in mMTC/IIoT scenarios), alternative cryptographic schemes tailored for constrained environments [86], should be considered.

Moreover, the authors of [87] investigated the utilization of TLS for communication between 5GC NFs. They demonstrated that while the use of TLS typically results in an overhead of less than 1%, there are instances, such as after a system reboot, where the overhead increases to around 30%, which can be prohibitive in an industrial setting. As they suggest, alternative protocols such as IPSec and WireGuard should be investigated.

Summary: Despite its optimizations and potential in terms of security, 5G still has significant challenges to overcome, especially concerning its secure integration into industrial networks. Further research is imperative to address crucial security aspects. The introduction of the wireless interface and new technologies in the architecture poses substantial threats to the system's availability. In many cases, preventative measures are lacking, and detection remains the primary approach. Additionally, even when security controls could potentially prevent an attack, they are often not implemented due to concerns regarding their impact on the system's performance.

6. Conclusion

5G stands out as the first and currently only wireless technology that meets the demands of industrial networks for reliable mobile connectivity and low latency. Consequently, an increasing number of companies start adopting 5G to leverage its multiple benefits without compromising any performance requirements. However, the advent of 5G significantly expands the attack surface of industrial networks by introducing multiple new components and a wireless interface. Therefore, the integration of 5G into industrial networks must prioritize security and safety as top concerns. In this paper, we provide a curated list of current state-of-the-art approaches essential for securely deploying and configuring a 5G network in an industrial setting, while also discussing promising opportunities to leverage existing technologies of 5G to further enhance security. Finally, we identify remaining challenges concerning 5G integration in industrial networks to fuel further research to address those. Overall, our work not only summarizes current research on securing industrial 5G networks and the exciting research challenges ahead but also provides industrial companies with a starting point to securely harness 5G capabilities.

This can unlock the potential for enhanced automation and mobility, inter-connection with vast cloud resources, and real-time operation, fulfilling the requirements of Industry 4.0 and IIoT.

Funding

Funded by the Deutsche Forschungsgemeinschaft (DFG, German Research Foundation) under Germany's Excellence Strategy – EXC-2023 Internet of Production – 390621612 and by the German Federal Office for Information Security (BSI) under project funding reference numbers 01MO23016D (5G-Sierra) and 01MO24003B (CSII). The responsibility for the content of this publication lies with the authors.

CRedit authorship contribution statement

Sotiris Michaelides: Conceptualization, Investigation, Writing – Original Draft, Visualization. **Thomas Vogt:** Investigation, Writing – Review & Editing. **Martin Henze:** Conceptualization, Writing – Review & Editing, Supervision, Funding acquisition

Declaration of competing interest

The authors declare that they have no known competing financial interests or personal relationships that could have appeared to influence the work reported in this paper.

Data availability

No data was used for the research described in this article.

References

- [1] E. D. Knapp, Industrial Network Security: Securing Critical Infrastructure Networks for Smart Grid, SCADA, and Other Industrial Control Systems, 2024.
- [2] M. Serror, S. Hack, M. Henze, M. Schuba, K. Wehrle, Challenges and Opportunities in Securing the Industrial Internet of Things, IEEE Transactions on Industrial Informatics.
- [3] A. Mahmood, L. Beltramelli, S. Fakhru Abidin, S. Zeb, N. I. Mowla, S. A. Hassan, E. Sisinni, M. Gidlund, Industrial IoT in 5G-and-Beyond Networks: Vision, Architecture, and Design Trends, IEEE Transactions on Industrial Informatics (2022) 4122–4137 doi : 10.1109/TII.2021.3115697.
- [4] J. Bodenhausen, C. Sorgatz, T. Vogt, K. Grafflage, S. Rötzel, M. Rademacher, M. Henze, Securing Wireless Communication in Critical Infrastructure: Challenges and Opportunities, in: Proceedings of the 20th EAI International Conference on Mobile and Ubiquitous Systems: Computing, Networking and Services (MobiQuitous), 2023.
- [5] M. Henze, M. Ortmann, T. Vogt, O. Ugus, K. Hermann, S. Nohr, Z. Lu, S. Michaelides, A. Massonet, R. H. Schmitt, POSTER: Towards Secure 5G Infrastructures for Production Systems, in: Proceedings of the 22nd Conference on Applied Cryptography and Network Security (ACNS) – Poster Session, 2024. doi : 10.1007/978-3-031-61489-7_14.
- [6] R. Langner, Stuxnet: Dissecting a cyberwarfare weapon, IEEE Security & Privacy 9 (2011) 49–51. doi : 10.1109/MSP.2011.67.
- [7] D. E. Whitehead, K. Owens, D. Gammel, J. Smith, Ukraine cyber-induced power outage: Analysis and practical mitigation strategies, in: 2017 70th Annual Conference for Protective Relay Engineers (CPRE), 2017, pp. 1–8. doi : 10.1109/CPRE.2017.8090056.
- [8] T. Krause, R. Ernst, B. Klaer, I. Hacker, M. Henze, Cybersecurity in Power Grids: Challenges and Opportunities, Sensors 21 (18). doi : 10.3390/s21186225.
- [9] O. Lasierra, G. Garcia-Aviles, E. Municio, A. Skarmeta, X. Costa-Pérez, European 5G security in the wild: Reality versus expectations, in: ACM WiSec, 2023. doi : 10.1145/3558482.3581776.
- [10] 5G-ACIA, 5G Non-Public Networks for Industrial Scenarios, last accessed: June 18, 2024 (2019). URL <https://5g-acia.org/whitepapers/5g-non-public-networks-for-industrial-scenarios/>
- [11] A. Rostami, Private 5G networks for vertical industries: Deployment and operation models, in: IEEE 2nd 5G World Forum, 2019. doi : 10.1109/5GWF.2019.8911687.
- [12] A. Aijaz, Private 5G: The future of industrial wireless, IEEE Industrial Electronics Magazine doi : 10.1109/MIE.2020.3004975.
- [13] ENISA, Security in 5G specification, last accessed: June 18, 2024 (2021). URL <https://www.enisa.europa.eu/publications/security-in-5g-specifications>
- [14] FCC, Report on recommendations for identifying optional security features that can diminish the effectiveness of 5G security, last accessed: June 18, 2024 (2021). URL <https://www.fcc.gov/file/20606/download>
- [15] 5G-ACIA, Security Aspects of 5G for Industrial Networks, Tech. rep., last accessed: June 18, 2024 (2021). URL <https://5g-acia.org/whitepapers/security-aspects-of-5g-for-industrial-networks/>
- [16] 5G-ACIA, 5G for Automation in Industry, last accessed: June 18, 2024 (2019). URL https://5g-acia.org/wp-content/uploads/2021/04/5G-ACIA_5G-for-Automation-in-Industry-.pdf
- [17] 5G-ACIA, Key 5G Use Cases and Requirements, last accessed: June 18, 2024 (2019). URL https://5g-acia.org/wp-content/uploads/2021/04/Key_5G_Use_Cases_and_Requirements_DOWNLOAD.pdf
- [18] S. Sullivan, A. Brighente, S. A. P. Kumar, M. Conti, 5g security challenges and solutions: A review by osi layers, IEEE Access (2021) 116294–116314 doi : 10.1109/ACCESS.2021.3105396.
- [19] A. Dutta, E. Hammad, 5G Security Challenges and Opportunities: A System Approach, in: 2020 IEEE 3rd 5G World Forum (5GWF), 2020, pp. 109–114. doi : 10.1109/5GWF49715.2020.9221122.
- [20] J. Falco, F. Proctor, K. Stouffer, A. Wavering, IT Security for Industrial Control Systems (2002). doi : <https://doi.org/10.6028/NIST.IR.6859>.
- [21] E. Byres, The air gap: Scada's enduring security myth, Communications of the ACM (2013) 29–31 doi : 10.1145/2492007.2492018.
- [22] J. Ke, Redundant wireless bridges: The reliability of wired networks with the cost savings of wireless, last accessed: June 18, 2024 (2015). URL https://www.solutions.adm21.fr/redundancy-technology/Redundant_Wireless_Bridges_The_Reliability_of_Wired_Networks_with_the_Cost_Savings_of_Wireless.pdf
- [23] 3GPP, TS 23.501 version 17.5.0 Release 17, Tech. rep. (2022).
- [24] P. Kehl, D. Lange, F. K. Maurer, G. Németh, D. Overbeck, S. Jung, N. König, R. H. Schmitt, Comparison of 5G Enabled Control Loops for Production, in: IEEE 31st IEEE Annual International Symposium on Personal, Indoor and Mobile Radio Communications, 2020.
- [25] A. Seferagic, J. Famaey, E. De Poorter, J. Hoebeke, Survey on wireless technology trade-offs for the industrial Internet of Things, Sensors doi : 10.3390/s20020488.
- [26] E. Oughton, W. Lehr, K. Katsaros, I. Selinis, D. Bublej, J. Kusuma, Revisiting wireless internet connectivity: 5G vs Wi-Fi 6, Telecommunications Policy doi : 10.1016/j.telpol.2021.102127.
- [27] W. Liang, J. Zhang, H. Shi, K. Wang, Q. Wang, M. Zheng, H. Yu, An experimental evaluation of WIA-FA and IEEE 802.11 networks for discrete manufacturing, IEEE Transactions on Industrial Informatics doi : 10.1109/TII.2021.3051269.
- [28] X. Jiang, M. Luvisotto, Z. Pang, C. Fischione, Reliable minimum cycle time of 5G NR based on data-driven channel characterization, IEEE Transactions on Industrial Informatics doi : 10.1109/TII.2021.3052922.
- [29] G. Americas, Understanding 5G time critical services, last accessed: June 18, 2024 (2022).

- URL <https://www.5gamericas.org/wp-content/uploads/2022/08/Understanding-5G-Time-Critical-Services-Aug-2022.pdf>
- [30] I. 802.1, Time-Sensitive Networking (TSN) Task Group, last accessed: June 18, 2024 (2020).
URL https://1.ieee802.org/tsn/#TSN_Standards
- [31] J. Farkas, L. L. Bello, C. Gunther, Time-Sensitive Networking Standards, *IEEE Communications Standards Magazine* doi:10.1109/MCOMSTD.2018.8412457.
- [32] D. Cavalcanti, C. Cordeiro, M. Smith, A. Regev, WiFi TSN: Enabling deterministic wireless connectivity over 802.11, *IEEE Communications Standards Magazine* (2022) 22–29 doi:10.1109/MCOMSTD.0002.2200039.
- [33] Ö. Sen, D. van der Velde, P. Linnartz, I. Hacker, M. Henze, M. Andres, A. Ulbig, Investigating Man-in-the-Middle-based False Data Injection in a Smart Grid Laboratory Environment, in: *Proceedings of 2021 IEEE PES Innovative Smart Grid Technologies Europe (ISGT-Europe)*, 2021. doi:10.1109/ISGTEurope52324.2021.9640002.
- [34] S. Nie, Y. Zhang, T. Wan, H. Duan, S. Li, Measuring the deployment of 5G security enhancement, in: *Proceedings of the 15th ACM Conference on Security and Privacy in Wireless and Mobile Networks, WiSec '22*, 2022, p. 169–174. doi:10.1145/3507657.3528559.
- [35] A. A. Abd EL-Latif, B. Abd-El-Atty, S. E. Venegas-Andraca, W. Mazurczyk, Efficient quantum-based security protocols for information sharing and data protection in 5G networks, *Future Generation Computer Systems* (2019) 893–906 doi:10.1016/j.future.2019.05.053.
- [36] E. J. Sacoto-Cabrera, L. Guijarro, J. R. Vidal, V. Pla, Economic feasibility of virtual operators in 5G via network slicing, *Future Generation Computer Systems* (2020) 172–187 doi:https://doi.org/10.1016/j.future.2020.03.044.
- [37] C. D. Alwis, P. Porabage, K. Dev, T. R. Gadekallu, M. Liyanage, A survey on network slicing security: Attacks, challenges, solutions and research directions, *IEEE Communications Surveys & Tutorials* (2023) 1–1 doi:10.1109/COMST.2023.3312349.
- [38] S. Köpsell, A. Ruzhanskiy, A. Hecker, D. Stachorra, N. Franchi, Open-RAN Risk Analysis, last accessed: June 18, 2024 (2022).
URL https://www.bsi.bund.de/SharedDocs/Downloads/EN/BSI/Publications/Studies/5G/5GRAN-Risk-Analysis.pdf?__blob=publicationFile&v=7
- [39] S. Behrad, E. Bertin, S. Tuffin, N. Crespi, A new scalable authentication and access control mechanism for 5G-based IoT, *Future Generation Computer Systems* (2020) 46–61 doi:https://doi.org/10.1016/j.future.2020.02.014.
- [40] I. Ahmad, T. Kumar, M. Liyanage, J. Okwuibe, M. Ylianttila, A. Gurtov, Overview of 5G Security Challenges and Solutions, *IEEE Communications Standards Magazine* 2 (2018) 36–43. doi:10.1109/MCOMSTD.2018.1700063.
- [41] 3GPP, TS 33.501 version 17.5.0 Release 17, Tech. rep. (2022).
- [42] M. Dahlmans, J. Lohmöller, J. Pennekamp, J. Bodenhausen, K. Wehrle, M. Henze, Missed Opportunities: Measuring the Untapped TLS Support in the Industrial Internet of Things, in: *Proceedings of the 17th ACM ASIA Conference on Computer and Communications Security (ASIA CCS)*, 2022. doi:10.1145/3488932.3497762.
- [43] R. Security, 5G SCAS evaluation access and mobility management function AMF 3GPP TS 33.512 version 16.3.0 Release 16), last accessed: June 18, 2024 (2022).
URL https://radix-security.com/files/2022/sample_report/sample_report.pdf
- [44] D. T. Hoang, C. Park, M. Son, T. Oh, S. Bae, J. Ahn, B. Oh, Y. Kim, LTESniffer: An Open-source LTE Downlink/Uplink Eavesdropper, in: *16th ACM Conference on Security and Privacy in Wireless and Mobile Networks (WiSec '23)*, 2023.
- [45] D. Rupperecht, K. Kohls, T. Holz, C. Pöpper, Breaking LTE on layer two, in: *2019 IEEE Symposium on Security and Privacy*, 2019. doi:10.1109/SP.2019.00006.
- [46] M. Akon, T. Yang, Y. Dong, S. R. Hussain, Formal Analysis of Access Control Mechanism of 5G Core Network, in: *Proceedings of the 2023 ACM SIGSAC Conference on Computer and Communications Security, CCS '23*, 2023, p. 666–680. doi:10.1145/3576915.3623113.
- [47] W. Yan, R. Chan, T. Truong-Huu, 5G Core Security: An Insider Threat Vulnerability Assessment, 2024.
- [48] S. Park, A. Shaik, R. Bargaonkar, J.-P. Seifert, Anatomy of commercial IMSI catchers and detectors, in: *Proceedings of the 18th ACM Workshop on Privacy in the Electronic Society, WPES'19*, Association for Computing Machinery, 2019, p. 74–86. doi:10.1145/3338498.3358649.
- [49] S. F. Mjølunes, R. F. Olimid, Easy 4G/LTE IMSI catchers for non-programmers (2017). *arXiv:1702.04434*.
- [50] M. Chlosta, D. Rupperecht, C. Pöpper, T. Holz, 5G SUCI-Catchers: Still catching them all?, in: *ACM WiSec, WiSec '21*, 2021. doi:10.1145/3448300.3467826.
- [51] X. Huang, T. Yoshizawa, S. B. M. Baskaran, Authentication Mechanisms in the 5G System, *Journal of ICT Standardization* (2021) 61–78 doi:10.13052/jicts2245-800X.921.
- [52] J. Vollbrecht, J. D. Carlson, L. Blunk, D. B. D. Aboba, H. Levkowitz, Extensible Authentication Protocol (EAP) (2004). doi:10.17487/RFC3748.
- [53] P. De Vaere, A. Tulimiero, A. Perrig, Hopper: Per-Device Nano Segmentation for the Industrial IoT, in: *Proceedings of the 2022 ACM on Asia Conference on Computer and Communications Security, ASIA CCS '22*, Association for Computing Machinery, New York, NY, USA, 2022, p. 279–293. doi:10.1145/3488932.3501277.
- [54] S. Wijethilaka, M. Liyanage, Realizing internet of things with network slicing: Opportunities and challenges, in: *IEEE 18th Annual Consumer Communications and Networking Conference*, 2021, pp. 1–6. doi:10.1109/CCNC49032.2021.9369637.
- [55] L. Bader, M. Serror, O. Lamberts, Ö. Sen, D. van der Velde, I. Hacker, J. Filter, E. Padilla, M. Henze, Comprehensively Analyzing the Impact of Cyberattacks on Power Grids, in: *Proceedings of the 2023 IEEE 8th European Symposium on Security and Privacy (EuroS&P)*, 2023. doi:10.1109/EuroSP57164.2023.00066.
- [56] R. Hussain, F. Hussain, S. Zeadally, Integration of VANET and 5G Security: A review of design and implementation issues, *Future Generation Computer Systems* (2019) 843–864 doi:https://doi.org/10.1016/j.future.2019.07.006.
- [57] ENISA, NFV Security in 5G - Challenges and Best Practices, Tech. rep., last accessed: June 18, 2024 (2022).
URL <https://www.enisa.europa.eu/publications/nfv-security-in-5g-challenges-and-best-practices>
- [58] M. J. Shayegan, A. Damghanian, A Review of Methods to Prevent DDOS Attacks Using NFV and SDN, in: *2023 9th International Conference on Web Research (ICWR)*, 2023, pp. 346–355. doi:10.1109/ICWR57742.2023.10139112.
- [59] G. W. De Oliveira, M. Nogueira, A. L. d. Santos, D. M. Batista, Intelligent VNF Placement to Mitigate DDoS Attacks on Industrial IoT, *IEEE Transactions on Network and Service Management* (2023) 1319–1331 doi:10.1109/TNSM.2023.3274364.
- [60] L. Zhou, H. Guo, G. Deng, A fog computing based approach to ddos mitigation in iiot systems, *Computers & Security* (2019) 51–62 doi:https://doi.org/10.1016/j.cose.2019.04.017.
- [61] S. Erokhin, A. Petukhov, P. Pilyugin, Critical information infrastructures monitoring based on software-defined networks, 2019.
URL <https://api.semanticscholar.org/CorpusID:201900161>
- [62] T. Garfinkel, M. Rosenblum, A Virtual Machine Introspection Based Architecture for Intrusion Detection, in: *Network and Distributed System Security Symposium*, 2003.
URL <https://api.semanticscholar.org/CorpusID:6136159>
- [63] W. O-RAN Alliance, O-RAN Architecture Description 12.0, Tech. rep. (2023).
- [64] H. Wen, P. Porras, V. Yegneswaran, A. Gehani, Z. Lin, 5G-Spector: An O-RAN Compliant Layer-3 Cellular Attack Detection Service, in: *Proceedings of the 31st Annual Network and Distributed System Security Symposium (NDSS'24)*, 2024.
- [65] D. Karnwal, Anomaly Detection Use Case, last accessed: June 18, 2024 (2021).
- [66] P. Kryszkiewicz, M. Hoffmann, Open ran for detection of a jamming attack in a 5g network, in: *2023 IEEE 97th Vehicular Technology Conference (VTC2023-Spring)*, 2023, pp. 1–2. doi:10.1109/VTC2023-Spring57618.2023.10201067.
- [67] K. Wolsing, E. Wagner, A. Saillard, M. Henze, IPAL: Breaking up Silos of Protocol-dependent and Domain-specific Industrial Intrusion Detection Systems, in: *Proceedings of the 25th International Symposium on Research in Attacks, Intrusions and Defenses (RAID)*, 2022. doi:10.1145/3545948.3545968.

- [68] S. Maesschalck, V. Giotsas, B. Green, N. Race, Don't get Stung, Cover your ICS in Honey: How do Honeypots fit within Industrial Control System Security, *Computers & Security* (2022) 102598doi:10.1016/j.cose.2021.102598.
- [69] M. Lichtman, R. Rao, V. Marojevic, J. Reed, R. P. Jover, 5G NR Jamming, Spoofing, and Sniffing: Threat Assessment and Mitigation, in: 2018 IEEE ICC Workshops, 2018, pp. 1–6. doi:10.1109/ICCW.2018.8403769.
- [70] A. Cetinkaya, H. Ishii, T. Hayakawa, Effects of Jamming Attacks on Wireless Networked Control Systems Under Disturbance, *IEEE Transactions on Automatic Control* (2023) 1223–1230doi:10.1109/TAC.2022.3153275.
- [71] Y. Arjoune, S. Faruque, Smart Jamming Attacks in 5G New Radio: A Review, in: IEEE 10th Annual Computing and Communication Workshop and Conference, 2020, pp. 1010–1015. doi:10.1109/CCWC47524.2020.9031175.
- [72] S. Barros, J. Bazzo, R. Takaki, D. Carrillo, J. Seki, LTE jamming mitigation based on frequency hopping strategies, in: 2016 8th IEEE Latin-American Conference on Communications (LATINCOM), 2016, pp. 1–6. doi:10.1109/LATINCOM.2016.7811609.
- [73] C.-Y. Lin, S. Nadjm-Tehrani, M. Asplund, Timing-Based Anomaly Detection in SCADA Networks, in: *Critical Information Infrastructures Security*, 2018, pp. 48–59.
- [74] ENISA, Security aspects of virtualization, Tech. rep., last accessed: June 18, 2024 (2017). URL <https://www.enisa.europa.eu/publications/security-aspects-of-virtualization>
- [75] O. AbdElRahem, A. M. Bahaa-Eldin, A. Taha, Virtualization security: A survey, in: 2016 11th International Conference on Computer Engineering & Systems (ICCES), 2016, pp. 32–40. doi:10.1109/ICCES.2016.7821971.
- [76] R. F. Olimid, G. Nencioni, 5G Network Slicing: A Security Overview, *IEEE Access* (2020) 99999–100009doi:10.1109/ACCESS.2020.2997702.
- [77] M. Jensen, J. Schwenk, N. Gruschka, L. L. Iacono, On Technical Security Issues in Cloud Computing, in: 2009 IEEE International Conference on Cloud Computing, 2009, pp. 109–116. doi:10.1109/CLOUD.2009.60.
- [78] J. C. Correa Chica, J. C. Imbachi, J. F. Botero Vega, Security in SDN: A comprehensive survey, *Journal of Network and Computer Applications* (2020) 102595doi:https://doi.org/10.1016/j.jnca.2020.102595.
- [79] T. Q. Thanh, S. Covaci, T. Magedanz, VISECO: An Annotated Security Management Framework for 5G, in: *Mobile, Secure, and Programmable Networking*, 2019, pp. 251–269.
- [80] B. B. Gupta, O. Badve, Taxonomy of DoS and DDoS attacks and desirable defense mechanism in a Cloud computing environment, *Neural Computing and Applications*doi:10.1007/s00521-016-2317-5.
- [81] D. Ryait, M. Sharma, To Eliminate the Threat of a Single Point of Failure in the SDN by using the Multiple Controllers, *International Journal of Recent Technology and Engineering (IJRTE)* (2020) 234–241doi:10.35940/ijrte.B3433.079220.
- [82] J. Hiller, M. Henze, M. Serror, E. Wagner, J. N. Richter, K. Wehrle, Secure Low Latency Communication for Constrained Industrial IoT Scenarios, in: *Proceedings of the 43rd IEEE Conference on Local Computer Networks (LCN)*, 2018. doi:10.1109/LCN.2018.8638027.
- [83] E. Wagner, M. Serror, K. Wehrle, M. Henze, BP-MAC: Fast Authentication for Short Messages, *WiSec '22*, 2022.
- [84] T. Heijligenberg, G. Knips, C. Böhm, D. Rupprecht, K. Kohls, BigMac: Performance Overhead of User Plane Integrity Protection in 5G Networks, in: *ACM WiSec, WiSec '23*, 2023. doi:10.1145/3558482.3581777.
- [85] 3GPP, TR 33.825 version 16.0.1 Release 16, Tech. rep. (2019).
- [86] Y. Zhong, J. Gu, Lightweight block ciphers for resource-constrained environments: A comprehensive survey, *Future Generation Computer Systems* (2024) 288–302doi:https://doi.org/10.1016/j.future.2024.03.054.
- [87] O. Zeidler, J. Sturm, D. Fraunholz, W. Kellerer, Performance Evaluation of Transport Layer Security in the 5G Core Control Plane, in: *Proceedings of the 17th ACM Conference on Security and Privacy in Wireless and Mobile Networks, WiSec '24*, 2024, p. 78–88. doi:10.1145/3643833.3656140.