

Before and After Blockchain: Development and Principles of Distributed Fault-Tolerant Consensus

HUANYU WU, James Watt School of Engineering, University of Glasgow, UK

CHENTAO YUE, School of Electrical and Computer Engineering, The University of Sydney, Australia

YIXUAN FAN, James Watt School of Engineering, University of Glasgow, UK

YONGHUI LI, School of Electrical and Computer Engineering, The University of Sydney, Australia

LEI ZHANG, James Watt School of Engineering, University of Glasgow, UK

The concept of distributed consensus gained widespread attention following the publication of “Byzantine Generals Problem” by Leslie Lamport in the 1980s. This research topic has been active and extensively studied over the last four decades, particularly since the advent of blockchain technology in 2009. Blockchain technology employs Proof-of-X (PoX) or Byzantine-fault-tolerant (BFT) systems, where all participants follow a protocol to achieve a common state (i.e., consistency) eventually. However, because PoX consensus such as Proof-of-Work is resource-intensive with high power consumption, most permissioned blockchains employ BFT to achieve consistency. In this article, we provide an introduction to the fundamental principles and history of distributed consensus. We then explore the well-known fault-tolerant state machine replication (SMR) in partially synchronous networks, as well as consensus protocols in asynchronous models and recently proposed DAG-based consensus. Additionally, we examine the relationship between BFT consensus and blockchain technology and discuss the following questions: What is the history and evolution of BFT? Why are BFT protocols designed in the way they are and what core components do they use? What is the connection between BFT and blockchain technology, and what are the driving needs for future BFT research?

CCS Concepts: • **Security and privacy** → *Distributed systems security*; • **Computer systems organization** → **Reliability**.

Additional Key Words and Phrases: Distributed systems, consensus, Byzantine fault tolerance, Blockchain, review

ACM Reference Format:

Huanyu Wu, Chentao Yue, Yixuan Fan, Yonghui Li, and Lei Zhang. 2024. Before and After Blockchain: Development and Principles of Distributed Fault-Tolerant Consensus. 1, 1 (August 2024), 53 pages. <https://doi.org/XXXXXXX.XXXXXXX>

1 INTRODUCTION

In the 1960s, engineers were considering using computers in space vehicles and aircraft control systems that comprised a central multiprocessor, dedicated local processors and multiplexed buses connect them. All these systems are mission-critical and processors in the multiprocessor are duplicated for error detection [75]. However, a challenge arose regarding how to ensure that all the multiple processes and machines could make consistent decisions on a consistent view. A

Authors’ addresses: **Huanyu Wu**, h.wu.3@research.gla.ac.uk, James Watt School of Engineering, University of Glasgow, G12 8QQ, Glasgow, Scotland, UK; **Chentao Yue**, chentao.yue@sydney.edu.au, School of Electrical and Computer Engineering, The University of Sydney, NSW 2006, Sydney, NSW, Australia; **Yixuan Fan**, y.fan.3@research.gla.ac.uk, James Watt School of Engineering, University of Glasgow, G12 8QQ, Glasgow, Scotland, UK, G12 8QQ; **Yonghui Li**, yonghui.li@sydney.edu.au, School of Electrical and Computer Engineering, The University of Sydney, NSW 2006, Sydney, NSW, Australia; **Lei Zhang**, lei.zhang@glasgow.ac.uk, James Watt School of Engineering, University of Glasgow, G12 8QQ, Glasgow, Scotland, UK, G12 8QQ.

Permission to make digital or hard copies of all or part of this work for personal or classroom use is granted without fee provided that copies are not made or distributed for profit or commercial advantage and that copies bear this notice and the full citation on the first page. Copyrights for components of this work owned by others than ACM must be honored. Abstracting with credit is permitted. To copy otherwise, or republish, to post on servers or to redistribute to lists, requires prior specific permission and/or a fee. Request permissions from permissions@acm.org.

© 2018 Association for Computing Machinery.

Manuscript submitted to ACM

Manuscript submitted to ACM

1

process refers to an instance running on a computer system that independently executes a specific task or a set of tasks. Subsequently, the problem of reaching an agreement in the presence of faults in a distributed system appears in the NASA-sponsored Software Implemented Fault Tolerant Project (SIFT) in the 1970s. The project aimed to create a resilient aircraft control system that could tolerate faults within its components. The famous work that introduced “Byzantine generals problem” by Leslie Lamport [100] in 1982 originated from this project. Since then, this problem has become a widely researched topic that has remained active for over four decades.

The network model in “Byzantine generals problem” is a synchronous network. In order to achieve synchrony, Lamport’s early work [109] focused on synchronising the clock of a group of processes. Based on the synchronous network, the problem can then be reduced to “reaching coordination despite Byzantine failure”, which is also named Byzantine agreement. However, Fischer, Lynch and Paterson (FLP) proved in 1985 that there is no deterministic algorithm that can solve Byzantine agreement in asynchronous network models even only one node has crash failure, known as FLP impossibility [61]. To solve this problem in the asynchronous model, several techniques have been utilised. Failure detector [29, 87, 110] and ordering oracle [36, 124] was introduced to reach consensus in the presence of crash-fault and Byzantine fault in asynchronous network. These oracles and detectors allow the protocols to circumvent FLP because they encompass some degree of synchrony, e.g., synchrony to detect the crash of a single process. However, it is still impossible to achieve the level of encapsulation of the original crash failure detector model when Byzantine failure exists [48]. Another way to achieve consensus is to use randomised consensus algorithm which was originally presented by Ben-Or [13]. The randomised consensus is not efficient, and its speed can be significantly boosted by the shared coin [17] (also known as Common Coin). Nevertheless, the most commonly used method is to relax the asynchrony assumption, i.e., utilising partially synchrony [52] or weakly synchrony. These network models are widely considered in many famous protocols, including practical Byzantine fault tolerance (PBFT) [26] and its variants, i.e., PBFT-based systems require weak synchrony to guarantee liveness.

SMR paradigm, which representing the state of the system as a state machine and ensuring that all replicas perform the same sequence of operations such that these replicas are consistent at all times, was initially introduced by Lamport [97] when he was finding solutions to correctly distributively replicate a service for critical systems. It was realised that the complex task of duplicating a service over multiple servers can be degraded to a simple task [97]; that is, when the user gives the same sequence of commands to all replicas, these commands must be processed with an identical succession of states in each replica. Unlike the Byzantine agreement, which focuses on one-time consensus, SMR offers a consecutive distributed replicated service. Later, fault-tolerant SMR solutions, including crash-fault-tolerant (CFT) and Byzantine-fault-tolerant (BFT) approaches, were proposed during the last decades. One of the most re-known CFT-SMR solutions is Paxos [98], which inspired subsequent works of Raft [122], Apache’s Zookeeper [77] and more. This paradigm has been used by many companies such as Google and Microsoft to replicate their computing infrastructure. The most famous BFT-SMR is PBFT [26], the introduction of which marked a significant turning point, demonstrating that BFT could be practically implemented to real-world systems, rather than remaining a purely academic interest. The throughput of PBFT has been improved by quorum-related hybrid solutions, especially when there is no fault in system, including Q/U [1], HQ [40] and Zyzzyva [93]. Furthermore, other forms of BFT protocol such as trusted hardware-based PBFT, certificate-based BFT and parallel BFT were investigated in [32, 35, 36, 83, 94, 156]

In 2008, the advance of Bitcoin [116] by Satoshi Nakamoto rekindled the interest of distributed consensus dramatically. Then, blockchain and distributed ledger technology (DLT) were abstracted from Bitcoin. Although it utilised a novel Proof-of-Work (PoW) consensus, Bitcoin is still in essence an SMR. Therefore, besides cryptocurrency consensus based on Proof-of-X (PoX), distributed fault tolerant algorithms used in SMR also became a highly researched area

in blockchain. A large amount of novel blockchain-oriented fault-tolerant consensus built upon SMR protocols were proposed, including BFT-SMaRt [15] and HotStuff [156], while related studies for practical asynchronous BFT includes Honey Badger BFT [113], BEAT [50], Dombo [72], etc. Recently, synchronous and asynchronous DAG-based BFT like DAG-Rider [86], Narwhal and Tusk [41] and Bullshark [137] were proposed, which are promising in terms of improving the parallel performance of BFT protocols by utilising graph architecture. In this article, we review the Byzantine fault tolerance consensus, from the origin to the recent development arouse by blockchain.

Why another review on distributed fault tolerance consensus? There are several existing surveys related to the topic of this article [10, 23, 69, 118, 144, 153, 157], which covers the utilisation and design of BFT in blockchain. Additionally, the traditional fault-tolerant SMR has been fully reviewed and discussed in [39, 44, 132, 157] in terms of its pros and cons. Compared with previous review papers, our article makes the following additional contributions. First, our article gives a comprehensive review of the origin and development of fault-tolerant consensus and SMR before and after the advent of blockchain, and it introduces easily-confused concepts such as Byzantine agreement and Byzantine broadcast from the perspective of the historical evolution of consensus. Second, this article categorises recent fault-tolerant consensus to different types, including synchronous, partial synchronous and asynchronous ones. It also introduces the important components of fault-tolerant consensus, such as randomness, and explains how they could be used to deal with different system and network assumptions. Third, the paper discussed the consensus designed for blockchain scenarios and analyses their design rationales, working principles and core elements. Furthermore, it explores future BFT research issues and potential use cases of blockchains. Readers can benefit from this article by gaining an understanding of the history and evolution of fault-tolerant consensus, from early solutions to current improvements, and how they can be utilised in practical blockchain systems. In addition, readers will develop insights into the different components of a consensus protocol, the principles guiding their design, and how to design a novel fault-tolerant protocol pecific deployment environments.

The development path of distributed fault-tolerance consensus that we have identified is illustrated in Fig. 1. Following the path, the rest of the paper is organised as follows. In section 2.1, we begin with the origin of (synchronous) Byzantine agreement and Byzantine generals problem . Then we introduce the famous FLP impossibility result and present how early solutions address this issue and give a introduction on state machine replication. Next, in section 3 we introduce the milestone PBFT and similar variants that use partially synchronous network model before and after blockchain. Following that, in section 4 we present practical consensus in asynchronous model which is conducted before the birth of blockchain but is again getting popular under the different requirements of blockchain from traditional SMR. In the next section 5, we explore recently proposed DAG-based BFT solutions and then summarise different fault-tolerant consensus. We then give guidance on future research issues, and summarise blockchain use cases with web3 visions to show the importance of the continuous research of BFT in section 7 and section 8.

2 CONSENSUS IN THE EARLY YEARS

2.1 Byzantine Agreement in Synchronous Model

In the 1960s, it becomes clear that computers will be used in space vehicles and aircraft control systems, such as those in the Apollo Project. These systems are mission-critical, and processors are duplicated for error detection. To ensure the multiple machines in the system share a consistent view or decision, NASA sponsored the Software implemented Fault Tolerant (SIFT) project [147] in the 1970s to build the ultra-reliable computer for critical aircraft control applications.

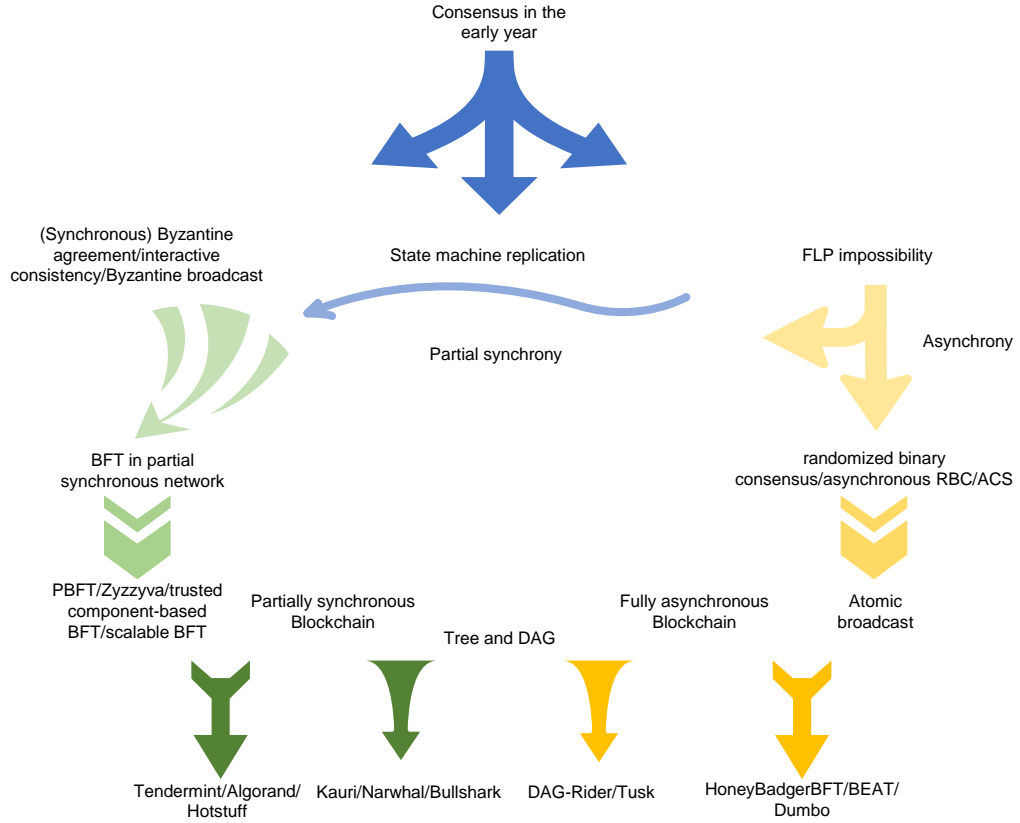

Fig. 1. Development path of consensus.

In SIFT for an aircraft controller, interactive consistency was needed to synchronise different processes, where each sensor supplies its local reading values of an environment of interest as the input.

DEFINITION 2.1. Interactive Consistency: Each process p_i inputs a value v_i , and each process outputs a vector V of such values, which satisfies:

- **Agreement:** Each correct process outputs the same vector V of values.
- **Validity:** If a correct process outputs V and a process p_i is correct and inputs v_i , then $V[i] = v_i$.

After reaching the agreement on an output vector, each process can derive its actions deterministically based on it.

Later, in 1982, Lamport wrote the paper [100] that inspired widespread interest in this problem by introducing the “Byzantine Generals Problem”. This paper introduced an agreement problem: Imagine several divisions of the Byzantine army planning to attack an encircled city. However, to win the war, the divisions must agree on a battle plan: attack or retreat. Some generals might want to attack, while others might choose retreat; some generals are loyal, and some might be traitors, preventing the loyal generals from reaching an agreement. The generals can only communicate with one another by messenger. An algorithm was needed to address the following conditions:

- CD1: All loyal generals decide on the same action.
- CD2: A small number of traitors cannot cause the loyal generals to adopt a bad plan

However, Lamport et al. found the second condition difficult to formalise as it requires a predefined “bad plan”. Therefore, they consider how the generals reach a decision. Byzantine generals problem can thus be abstracted as follows: A commanding general must send an order to his $n - 1$ lieutenant generals such that

- CD3: All loyal lieutenants obey the same series of orders. (Agreement)
- CD4: If the commanding general is loyal, then every loyal lieutenant obeys the order he sends. (Validity)

The Byzantine generals problem is equivalent to **Byzantine broadcast**, a broadcast primitive where a sender starts with an input value v and others have no input. During the broadcast, the sender conveys its input to all processes in such a way that, at the end of the broadcast, all processes output the same value.

Readers might wonder, what if in CD4 the commanding general is not loyal? In fact, the commanding general does not have to be loyal. When Byzantine broadcast is solved, to address CD1 and CD2, we only have to build n , (i.e., the total number of generals) Byzantine broadcast instances in parallel, one for each process. CD1 can be achieved by having all the generals use the Byzantine broadcast method to gather information, and CD2 can be achieved by a robust method, e.g., if the only decision is whether to attack or retreat, (i.e., the decision value is binary), then the final decision can be achieved based on a majority vote among all the orders gathered during the Byzantine broadcast.

Following Byzantine generals problem, we introduce the notion of Byzantine agreement:

DEFINITION 2.2. Byzantine Agreement. *In this primitive, every process holds an input value and outputs again a single value, and all processes satisfy*

- **Agreement.** *Each correct process outputs the same value.*
- **(All-Same) Validity.** *If all the correct processes have the same input value v , then they output the same output v .*

Note that the notion of *validity* encompasses many subtle definitions. The original validity condition mentioned above may not be practical when correct processes start with different input values, as this could result in no agreed output. One possible solution is to set the output value to a default value \perp in such cases. Other validity terminologies include requiring that the output value was input by any process, known as Any-Input Validity [146], or ensuring that the output value is the input from a correct process, referred to as Correct-Input Validity [146]. In some contexts, external-validity [21] is necessary, which requires that the agreed value is legal according to a global predicate known to all parties and determined by the specific higher-level application. Different subtle definitions of validity are considered based on varying assumptions and research questions.

Lamport proposed two solutions for the (synchronous) Byzantine agreement problem and its variations: an oral message solution and a signature based solution [100]. These solutions incur exponentially large communication costs, hence are also called exponential information gathering [108]. After the pioneering work of Lamport, Byzantine agreement solutions with polynomial complexity were developed [46]. Synchronous Byzantine agreement protocols were rarely implemented in real systems, and this problem was considered to be primarily of academic interest until the introduction of PBFT [26]. Therefore, we will not elaborate on these solutions in detail but only introduce the key concepts behind them.

► **Remark.** It is important to note that even though the Byzantine Generals Problem does not explicitly state timing assumptions, it inherently necessitates that all generals make their decisions prior to executing their attacking or retreating. In other words, all messages must be delivered before the final decision is made, which essentially assumes a

synchronous system. Working on synchronous algorithms for Byzantine agreement made Lamport realise that clock synchronisation among the processes was necessary [109].

Byzantine agreement could be built on top of **interactive consistency** [109]. In this approach, the processes first run interactive consistency to agree on an input value for each process, after which every process locally runs a deterministic procedure to determine the output according to the validity requirement of Byzantine agreement. **Byzantine broadcast** could be built on top of **Byzantine agreement** [109]. Here, the sender process p_s first sends its value to each process, then all processes run **Byzantine agreement** once, whereby each correct process uses the value received from p_s as its input. Intuitively, **Byzantine broadcast** could also be extended to build **interactive consistency**, where each correct process uses **Byzantine broadcast** once to finally construct the same vector. In summary, **interactive consistency**, **Byzantine broadcast**, and **Byzantine agreement** can be implemented based on one another. All of these three notions presented here are designed for a synchronous network; note that there is no explicit termination property, as they all implicitly assume that every message arrives within a bounded time and the processes terminate naturally.

2.2 FLP Impossibility and Asynchronous Solutions

In 1985, Fischer, Lynch, and Paterson (FLP) [60, 61] proved a famous result in the field of distributed systems, stating that in an asynchronous system, a **deterministic** consensus protocol is impossible to achieve even in the simple case of having only one Fail-Stop (crash) process. Readers can refer to the original papers for the formal proof. To help readers understand the theory, we will give a simplified, informal example:

Assume five processes A, B, C, D, and E that need to decide whether to submit a transaction. Every process has a binary initial value, namely submit (1) or rollback (0). They will send their initial values to each other to reach an agreement. Therefore, each process needs to make a decision based on their received messages from other processes. We assume that at most one process can crash, and thus the requirement of agreement is that all of the other four correct processes must get a consistent decision (either 0 or 1). Consider a deterministic algorithm P, in which every process makes the decision based on the majority value. Now, C's initial value is 0, so C broadcasts 0 and it receives 1 from A and B, and 0 from D. Now, both 0 and 1 have two votes, and the value from E will determine the final result. Unfortunately, E crashes, or E is suffering from a network partition and the message from E is delayed forever. In this scenario, C can decide to wait forever until it receives the message from E, but in an asynchronous network, C will not be able to know if E has crashed or is simply slow. As a result, it is possible that C may never make a decision. Alternatively, C might choose a decision based on some predefined deterministic rule; w.l.o.g., we say, C decides on 1. Unfortunately, C crashes just after it makes the decision, and the decision is not sent to the others. Meanwhile, E just recovers from the network partition, and receives 1 from A and B, and 0 from C and D. Now, E's decision depends on its initial value; w.l.o.g., the initial value of E is 0, so E decides on 0, which violates the agreement requirement that all processes must decide on the same value, either 0 or 1.

FLP impossibility is regarded as a milestone in distributed system research. Several solutions have been proposed to avoid the FLP impossibility and enable practical implementations. One possibility is to add failure detectors and oracles [29, 36, 52, 87, 110, 124], but it was later realised that although this approach works fine in a crash-fault environment, it is impossible to achieve the same level of encapsulation as the original crash failure detector model when Byzantine failures exist [48]. Moreover, these oracles generally require a trusted environment, e.g., trusted hardware. Another possibility is to loosen the network assumptions, moving from asynchrony to partial synchrony (a.k.a. almost-asynchrony, weak synchrony). Partial synchrony was implicitly considered in many famous practical

CFT and BFT consensus protocols, including PBFT [26]. Apart from these solutions, randomisation can be used to achieve agreement in a completely asynchronous network, the idea of which was originally presented by Ben-Or [13]. In summary, the solutions for asynchronous network guarantee whether the network is synchronous, no honest process will be different from each other (i.e., agreement), but the asynchronous network might make the system halt forever (influence termination), and therefore, they make one of the following trade-offs regarding termination:

- Termination is guaranteed only if the network is partially synchronous (such as PBFT).
- Termination is guaranteed with probability 1 (such as Ben-Or's).

2.3 Early Randomised Protocols in Completely Asynchronous Model

In the previous section 2.1, all the protocols assume synchronous communication, so termination is ignored, as all processes have a global clock and are expected to follow the protocol until the final bounded step. In other words, all correct processes decide within r rounds, for some previously known constant r [17]. However, the situation changes in the asynchronous model. As presented in 2.2, it is impossible to find a deterministic solution to address the problem in an asynchronous model, and most solutions loosen the termination condition to avoid the FLP impossibility. In this section, we focus on solutions that apply the loosened termination requirement, guaranteeing termination with probability 1. This means that a protocol may never terminate, but the probability of this occurring is 0, and the expected termination time is finite. Two approaches are widely adopted: The first approach is to add random steps into the protocol [13], while the second postulates some probabilistic behaviour about the message system [17]. Before we proceed, we would like to introduce the notion of consensus, which is easily confused with the term “Byzantine agreement”.

DEFINITION 2.3. Consensus Protocols: *A consensus protocol is a protocol used in a group of processes where each process has an initial value and can propose this value. The protocol satisfies the following properties:*

- **Agreement:** *If two (correct) processes a and b decide values v_a and v_b , respectively, then $v_a = v_b$.*
- **Validity:** *If a (correct) process decides a value v , then v must be the initial value of some process.*
- **Termination:** *If a (correct) process decides a value, then all correct processes eventually decide a value.*

Note that the definition could be slightly different for crash failures and Byzantine failures. In crash failures, all processes follow the code, but in Byzantine failures, processes could behave arbitrarily. The correct processes means these properties only hold for correct nodes, because a faulty node especially a Byzantine one can do anything, but some times “correct” is not written but known as an implicitly requirement. Therefore, in the definition for Byzantine failures, we only require that the correct processes satisfy the properties.

Recall that the definition 2.2 of Byzantine agreement (in a synchronous model does not include a “termination” condition. In recent research, especially in SMR and blockchain, consensus is sometimes required to be “totally ordered”, which we will introduce later in Section 2.4.

2.3.1 Ben-Or's Randomised Consensus. In 1983, Ben-Or proposed the first probabilistic solution to the asynchronous agreement problem [13]. The protocol of Ben-Or uses binary values for the initial value and decision value, which are elements of $\{0,1\}$. In this work, due to the asynchronous assumption, there are no global time or clocks. Instead, this protocol advances in rounds, and in each process p 's local view, a round could be regarded as a local clock for p . During the protocol, a message is assumed to eventually be delivered. We now take a brief look at Ben-Or's original protocol with **crash failures**:

0. In the initial step, process p sets value v as the proposal at local round number $r_p = 1$.

1. Phase 1:

(a) Broadcast $\langle phase = 1, round = r_p, value = v_p \rangle$.

(b) Wait to receive more than $N - t$ different messages $\langle phase = 1, round = r_p, value = * \rangle$ from others (where N is the total number of processes).

(c) If all the received messages in (b) contain the same value v , then p sets $v_p = v$, otherwise it sets $v_p = \perp$.

2. Phase 2:

(a) Broadcast the message $\langle phase = 2, round = r_p, value = v_p \rangle$.

(b) Wait for more than $N - t$ different messages $\langle phase = 2, round = r_p, value = * \rangle$ from others.

(c) Choose one of the following actions:

(i) If all messages contain the same non- \perp value v , then decide v .

(ii) If one of the messages contains a non- \perp value v , then accept v by setting $v_p = v$. Otherwise, accept a random estimate by setting $v_p \in \{0, 1\}$ randomly with 50% probability.

3. $r_p = r_p + 1$ and **goto** Step 1.

In the following paragraphs, we explain how Ben-Or's protocol work for asynchronous environment. First, let us check the weak validity in crash-fault model.

DEFINITION 2.4. Weak Validity. *If all processes are honest and start with the same initial value v , then the decision value must be v .*

It is clear that if all processes are non-faulty and start with the same v , they will all send $\langle phase = 1, 1, v \rangle$ and will receive more than $N - f$ $\langle phase = 1, 1, v \rangle$ messages after one round. Consequently, they will send and receive enough $\langle phase = 2, 1, v \rangle$ messages and thus decide on v .

Before verifying agreement property, we introduce the notion of Quorum:

DEFINITION 2.5. Quorum, and Quorum system. *Let $P = \{p_1, \dots, p_n\}$ be a set of processes. A quorum $Q \subseteq P$ is a subset of these processes. A quorum system $S \subseteq 2^{|P|}$ is a set of quorums such that every two quorums intersect, i.e., for any $Q_1, Q_2 \in S$, $Q_1 \cap Q_2 \neq \emptyset$.*

Then, we introduce the notion of quorum intersection that is used in Ben-Or's consensus.

DEFINITION 2.6. $N/2+1$ -Quorum Intersection *Let S_1 with $|S_1| \geq \frac{N}{2} + 1$ and S_2 with $|S_2| \geq \frac{N}{2} + 1$. Then, there exists at least a correct process in $S_1 \cap S_2$.*

Next, we verify the agreement property, which states every process must decide on the same value. The agreement property can be proven by the following claims:

LEMMA 2.1. *It is impossible for $\langle phase2, r_p, 1 \rangle$ and $\langle phase2, r_p, 0 \rangle$ messages to exist simultaneously due to quorum intersection. W.l.o.g., sending $\langle phase2, r_p, 1 \rangle$ requires at least $\frac{N}{2} + 1$ processes to have the same value, so $\langle phase2, r_p, 1 \rangle$ and $\langle phase2, r_p, 0 \rangle$ is impossible to exist simultaneously, as this would require $N + 2 > N$ processes, which is a contradiction.*

LEMMA 2.2. *If some process receives $\frac{N}{2} + 1$ messages of the form $\langle phase2, r_p, v \rangle$, then all processes will receive at least one message of the form $\langle phase2, r_p, v \rangle$. This is because at least one of the $\frac{N}{2} + 1$ processes that sent $\langle phase2, r_p, v \rangle$ is non-faulty, which again follows from quorum intersection.*

Combining both lemmas, we can conclude that for some round r , if a process decides v in step (c)(i), then all other non-faulty processes will decide v within the next round.

Finally, let us check why this protocol satisfies termination. Consider the worst case, where no process decides in round r and only \perp messages are received in phase 2. In this case, processes will accept a random value, so there is a chance, albeit small, that all processes accept the same random value v in the next round, and the protocol terminates (by weak validity). Each round has a nonzero chance of deciding, and although the chance could be small, if the protocol runs for an infinite number of rounds, it will satisfy termination with probability 1. Note that this protocol is not efficient, but it proves that it is possible to find a solution to the consensus problem in a completely asynchronous model. The correctness of Ben-Or's protocol was proven in 1998 [4]. This kind of solution is also called a random coin protocol, as it resembles every node tossing a coin, and the protocol terminating when every node's coin lands on the same side. The performance could be improved if we set every process to toss the same coin, called a **Shared Coin** (a similar notion is **Common Coin**[134]). The concept of the Shared coin is based on the notion of shared memory[28]. With the development of cryptography and after the invention of threshold cryptosystems [43], a shared coin can also be built on the threshold signature scheme (TSS) or the verifiable random function (VRF) [112].

DEFINITION 2.7. A (t, n) -**Threshold Signature Scheme (TSS)** is a signature scheme that generates a valid and unforgeable single digital signature only if at least t out of the n participants provide their approvals.

DEFINITION 2.8. A **Verifiable Random Function (VRF)** is a function in which each participant i is equipped with a secret key sk_i and the corresponding public key pk_i , and for any input x , $VRF_{sk_i}(x)$ returns two values: hash and proof. The hash is a fixed-length value determined by the pair (sk_i, x) and is indistinguishable from random values to anyone who does not know sk_i . The proof enables anyone who knows pk_i to verify that the hash corresponds to x without needing to know sk_i .

Ben-Or's protocol also has a Byzantine version if slight modifications are made into the quorum intersection. In the Byzantine environment, Ben-Or's protocol can tolerate $f = \frac{N}{5}$ Byzantine processes. Readers can refer to [13] for the Byzantine version modification.

2.3.2 Asynchronous Reliable Broadcast Protocol.

It is widely known that Byzantine consensus can tolerate up to $f = \frac{N}{3}$ Byzantine processes, where N is the total number of processes. Bracha and Toueg proved this lower bound in [18]. However, in Ben-Or's protocol, whether there are asynchronous consensus protocols that can tolerate up to $t < \frac{N}{3}$ remains an open question. Bracha [17] extended the maximum number of tolerated Byzantine processes to meet the lower bound of $f = \frac{N}{3}$. As introduced in the last paragraph, Ben-Or's Byzantine version modified the quorum intersection to tolerate Byzantine processes. Different from Ben-Or's protocol, which deals with Byzantine processes directly (by quorum intersection), Bracha uses a novel technique to reduce the effect of Byzantine processes, to limit their behaviour. This technique is composed of two parts, a broadcast primitive and a validation mechanism. By utilising the reliable broadcast primitive, a crash process or a Byzantine process can either send no messages or the same message to all correct processes. In other words, the behaviour of a Byzantine process is filtered by the reliable broadcast primitive, thereby reducing the affect of faulty processes. Then the validation mechanism forces faulty processes to send messages that could have been sent by correct processes. We now give the definition of reliable broadcast:

DEFINITION 2.9. **Reliable Broadcast (RBC).** A protocol is a reliable broadcast protocol if:

- If process p is correct, then all correct processes agree on the value of the message it broadcasts. (Validity)
- If p is faulty, then either all correct processes agree on the same value or none of them agree on any value p broadcasts. (Totality/Agreement)

We briefly review of Bracha's reliable broadcast.

0. initial. leader (sender) with input v and sends $\langle v \rangle$ to all processes.
for each process p (including the leader): $\text{echo}=\text{ture}$, $\text{vote}=\text{true}$
 1. Phase 1: on receiving $\langle v \rangle$ from leader
if $\text{echo} == \text{true}$: **send** $\langle \text{echo}, v \rangle$ to all processes and **set** $\text{echo} = \text{false}$
 2. Phase 2: on receiving $\langle \text{echo}, v \rangle$ from $N - f$ distinct processes:
if $\text{vote} == \text{true}$: **send** $\langle \text{vote}, v \rangle$ to all processes and **set** $\text{vote} = \text{false}$
 3. Phase 3: on receiving $\langle \text{vote}, v \rangle$ from $f + 1$ distinct processes:
if $\text{vote} == \text{true}$: **send** $\langle \text{vote}, v \rangle$ to all processes and **set** $\text{vote} = \text{false}$
 4. Phase 4: on receiving $\langle \text{vote}, v \rangle$ from $N - f$ distinct processes: **deliver** v .
-

Next, we explain why this reliable broadcast mechanism works. First, we check the validity property. If the sender is correct, it will send v to everyone, then all correct processes will send $\langle \text{echo}, v \rangle$ and every correct one will eventually receive at least $N - f$ echoes for v and at most f echoes for other values. Therefore, all correct processes will send $\langle \text{vote}, v \rangle$ in step 2 and will receive $n - f$ $\langle \text{vote}, v \rangle$ and at most f votes for other values. Hence, all correct processes will eventually deliver v .

Next, we verify the totality/agreement property. We first prove by contradiction that no two correct processes will vote for conflicting values: consider two votes sent in phase 2 for v and v' ($v \neq v'$) from processes a and b , respectively. Process a must have seen $N - f$ echoes for v , and process b must have observed $N - f$ echoes for v' . However, this is impossible due to quorum intersection, as $2 \times (N - f) \geq f + 1$, which means at least $f + 1$ processes must have sent an echo to both v and v' , which is a contradiction. Now, we know that correct processes only vote for the same value. Therefore, if a correct process delivers a value (i.e., agrees on a value), it must have seen $N - f$ votes, of which at least $N - f - f \geq f + 1$ votes come from correct processes. Thus, every correct process will eventually deliver the same value v , either due to observing $N - f$ echoes for v or due to seeing $f + 1$ votes for v from $f + 1$ correct processes. Otherwise, no correct process will ever deliver/agree on any value. Readers can refer to [17] for the complete correctness proof.

By utilizing the reliable broadcast primitive, the power of faulty (Byzantine) nodes is restricted. Hence, Bracha's protocol improves upon Ben-Or's protocol by reducing the required number of processes from $N > 5f$ to $N > 3f$.

2.4 State Machine Replication

To begin with, we first consider the most simplified State Machine Replication (SMR) model with crash failure and a synchronous network. The notion of SMR first appeared in a report [80]. The authors aimed to keep different copies of a database eventually consistent while allowing different copies to update operations independently. The solution to this problem was first introduced in Lamport's paper [96], which is notable for defining logical time and causality in distributed systems. However, it also introduced the insight that by applying commands in the same order at all the copies in a distributed system, the copies can remain consistent with each other. In other words, each replica contains a local copy of a state machine. If initialised to the same initial state, SMR is achieved when different replicas execute the

same commands in the exact same order on their local copies. The algorithm that implements a universal state machine in a distributed system by replication is called the SMR algorithm. The first solution for implementing SMR [96] did not consider failures. Algorithms addressing failures were proposed later. The well-known crash-fault-tolerant algorithm Paxos [98] and the Byzantine-fault-tolerant algorithm PBFT [26] were introduced successively.

Generally, there are two approaches to implementing an SMR: consensus protocols and total ordering protocols. These two approaches are essentially equivalent. We provide the definition of a total ordering protocol:

DEFINITION 2.10. Total Ordering Protocols. *A total ordering protocol is a protocol in which processes broadcast messages to one another, while the following properties are satisfied:*

- **Agreement.** *If two (correct) processes deliver the same two messages, they deliver them in the same order.*
- **Validity.** *If a (correct) process delivers a message, it must be a message sent by some process.*
- **Termination.** *A message delivered by a correct process is eventually delivered to all correct processes.*

A total ordering protocol only needs to be started once to build an SMR, as it is a protocol that delivers consecutive messages (commands), once these commands are delivered with order and executed by each process with the same sequence, SMR is built. Instead, consensus protocols need to be triggered for each time slot in the sequence of commands to an SMR. In short, SMR could also be built on “repeated consensus”. Total ordering protocol could be built out of a consensus protocol and vice versa.

A total ordering protocol only needs to start once to build an SMR, as it delivers consecutive messages (commands). Once these commands are delivered in order and executed by each process in the same sequence, SMR is built. In contrast, consensus protocols need to be triggered for each time slot in the sequence of commands for SMR. In short, SMR can also be built on “repeated consensus”. In another word, the total ordering protocol is a service to deal with consecutive requests, while consensus could be used once for each request, and needs to be triggered for every message. A total ordering protocol can be built out of a consensus protocol and vice versa.

We then give the definition of a related broadcast primitive.

DEFINITION 2.11. Atomic Broadcast, a.k.a. Total Order broadcast. *Atomic Broadcast is a type of broadcast primitive that where all correct processes receive the same set of messages in the same order while satisfying the following properties:*

- **Validity.** *If a correct process broadcasts a message, all correct processes eventually receive it.*
- **Agreement.** *If a correct process receives a message, then all correct processes eventually receive it.*
- **Integrity.** *A message will be received by each process only once, and only if it was broadcasted previously.*
- **Total order.** *If two processes p_1 and p_2 deliver two messages m_1 and m_2 such that one correct process receives m_1 before m_2 , then every other correct process must receive m_1 before m_2 .*

Note that Atomic Broadcast can be used to realise SMR with an even stronger guarantee by ensuring that all broadcasted messages are included. It is a sender-receiver model broadcast primitive where each process has no initial value except the sender. Similar to the total ordering protocol, atomic broadcast can be converted to consensus, and conversely, consensus can be reduced to atomic broadcast.

Although synchronous network assumption simplifies the SMR problem, it is not practical as the assumption is unrealistic for real computing environment. In addition, recall that the FLP impossibility result shows that solving deterministic consensus problems in an asynchronous network is impossible. Therefore, most protocols provide only agreement (safety) during asynchrony and make one of the following trade-offs for termination (liveness):

- Guarantees termination only when the network is partial synchronous (the network will sometimes be synchronous anyway, e.g., PBFT).
- Guarantees termination with probability 1 (e.g., Ben-Or’s consensus).

Here we introduce safety and liveness properties [121]:

- **Safety:** A safety property states that something “bad” never happens. In a BFT context, this means behaving like a centralised implementation that executes operations atomically one at a time, i.e., the nodes agree on a valid value proposed by one of the nodes.
- **Liveness:** A liveness property states that something “good” eventually happens. In a BFT context, the nodes eventually reach agreement, i.e., the system must make progress.

3 PRACTICAL BFT IN PARTIAL SYNCHRONOUS NETWORK

As introduced above, no deterministic consensus algorithm exists in a fully asynchronous network, and two trade-off schemes are used to address this problem. In this section, we focus on deterministic protocols in a partial synchronous network. Most practical BFT protocols, including PBFT, provide the safety property consistently, but liveness is only guaranteed when the network is synchronous (after applying the Global Stabilisation Time, GST). These protocols are generally leader-based, meaning that one of the replicas acts as a leader while others are followers. This kind of protocol usually has three sub-protocols: the normal-case agreement protocol, the view change protocol, and the garbage collection protocol (checkpoint/snapshot). A “view” is a configuration of replicas, i.e., who is the leader and who are the followers. We focus on the former two protocols as they are important to safety and liveness. If the leader is correct, followers run the normal-case agreement protocol, and when the leader is suspected to be faulty, followers run the view change protocol to elect a new leader. If a sufficient number of followers trigger the view change protocol, a correct leader will be elected.

In this section, we categorise BFT in partially synchrony into broadcast-based message-passing BFT, parallel BFT and trusted hardware-based BFT. For each category, we analyse several widely known algorithms as examples to demonstrate in detail how they work.

3.1 The Most Popular Type of BFT: Broadcast and Message-Passing-based BFT

Broadcast-based message-passing BFT generally consist of several one-to-all and all-to-all phases, indicating that in these protocols, every process needs to exchange information with others through a communication channel. Message-passing is the most commonly used form of BFT protocols. This category of BFT protocols is divided into different phases, and each process gathers information through different phases. The follower processes also need to monitor the behaviour of the leader to ensure that current leader is correct.

3.1.1 SMR-based Total Ordering Protocol: PBFT.

PBFT is the first and perhaps the most instructive practical BFT protocol to achieve SMR in the presence of Byzantine nodes. Only after its development did people realise BFT is not only a complex problem of academic interest but also a practically solvable issue.

We first examine the cryptography assumptions in PBFT. In this protocol, cryptographic techniques are used to prevent spoofing and replays and to detect corrupted messages. Each PBFT message contains public-key signatures, message authentication codes (MACs), and message digests generated by collision-resistant hash functions. All replicas know each other’s public keys to verify signatures, meaning that a pre-set public key infrastructure (PKI) is needed.

PBFT assumes that although the adversary is strong enough to coordinate faulty processes, it is bounded by computing power and cannot subvert the cryptographic techniques. This means, for example, the adversary cannot produce a valid signature of a non-faulty node or break the hash (digest) function. In early consensus protocols, there was an assumption that the receiver can distinguish the message sender, e.g., by Media Access Control (MAC) address and IP. Note this assumption is different from the cryptographic assumptions in PBFT. For example, a process in PBFT observing two messages from the same sender with different values but valid signatures can prove the sender is faulty, but identifying the sender does not mean faulty messages equivocal messages can be detected.

Other assumptions employed by PBFT include: replicas are connected by a network, where an adversary can coordinate faulty nodes, delay communication, or delay correct nodes in order to cause the most damage to the replicated service [26]. The network model is mostly asynchronous, meaning the delay between the time t when a message is sent and the time it is received by its destination does not increase indefinitely. However, the asynchronous network also has periods of synchrony to ensure liveness. The bound on the number of faulty nodes is $f \leq \frac{N-1}{3}$, where N is the total number of nodes.

Before exploring the agreement protocol of PBFT, readers should be aware that PBFT is a total ordering protocol in which the safety property is ensured by guaranteeing all non-faulty replicas agree on a total order for the execution of requests despite failures. Recall that a total ordering protocol is equivalent to a consensus protocol but differs in operation when building an SMR. Now, we examine how PBFT achieves agreement on a unique order of requests within a view (when the leader is correct). Our introduction of PBFT is based on the simplified version (without checkpoint) [146].

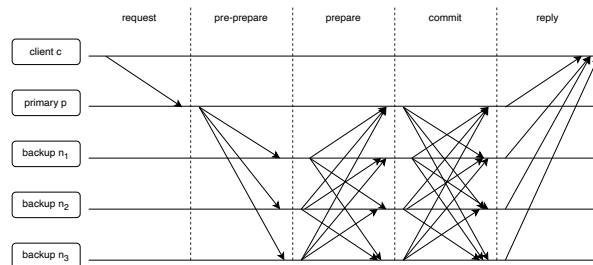

Fig. 2. Agreement protocol in PBFT

- (1) The leader l receives a request r from a client, picks the next sequence number s , and sends $pre\text{-}prepare(s,r,l)$ to all followers, informing them of the intended execution of the request with the specified sequence number.
- (2) For a backup follower b , upon receiving $pre\text{-}prepare(s,r,l)$, if l is the leader and b has not yet accepted a $pre\text{-}prepare$ for the sequence s , it sends $prepare(s,r,b)$ to all other processes to confirm they agree with the leader's suggestion. Once the backup b has sent $prepare$, we say b is pre-prepared for (s, r) .
- (3) After being pre-prepared for (s, r) , a backup follower b waits until it collects $2f$ $prepare$ (including its own) and, together with the $pre\text{-}prepare$ one, they form a *certificate of prepare* with $|\text{certificate of prepare}| = 2f + 1$.
- (4) Once the certificate is gathered, a process p (leader and follower) sends $commit(s,p)$ to all processes.
- (5) Process p waits until $2f + 1$ $commit$ messages matching sequence s have been accepted, and executes request r after all previous requests with lower sequence numbers have been executed.

- (6) Process p sends *reply* (r, p) to the client.

Then, we analyse how this agreement protocol works within a view v when the leader is correct.

LEMMA 3.1. (*PBFT: Agreement within a view*) *Within a view when the leader is correct, if a process gathers a certificate for pre-prepare (s, r), where s is the sequence number and r is the request, then no process can gather a certificate for pre-prepare (s, r') with $r \neq r'$. This ensures that PBFT achieves a unique sequence number within a view.*

PROOF. Assume two (even one is enough) processes gather certificates for (s, r) and (s, r'). Because a *certificate* for prepare contains $2f + 1$ messages, a correct process must sent a *pre-prepare* or *prepare* message for (s, r) and (s, r'), respectively (quorum intersection). However, a correct leader only sends a single *pre-prepare* for each (s, r), and a correct follower only sends a single *prepare* for each (s, r). This creates a contradiction. \square

It might raise a concern about why the *commit* message is necessary, since *pre-prepare* and *prepare* seem sufficient to tolerate Byzantine faults as proven in Lemma 3.1. Note that Lemma 3.1 only guarantees agreement on the unique order within a single *view* when the leader is correct, whereas *commit* protects agreement *across views*, i.e., when the leader is faulty and a new one is elected.

If the leader is faulty, the system needs a view change to move to the next leader's view to continue progress. In the original design, a faulty-timer is embedded in each follower to detect the failure of the leader. The fault of the leader could also include malicious behaviors, e.g., sending conflicting sequences. Now we introduce how PBFT handles the view change phase. We first describe the protocol for followers during *view change*.

-
- (7) When a follower backup b 's local timer expires or it detects faulty behaviour from the leader in view v , it enters *view change phase* and stops accepting *pre-prepare/prepare/commit* messages from view v .
 - (8) b Gathers P_c , the set of all *certificate of prepare* that b has collected since system started. Note this could be optimised by *checkpoint*, the certificates since system started could be reduced to certificate since last valid checkpoint in this way. Here we only consider the simplest mechanism to help better understanding.
 - (9) b sends *view-change*($v+1, P_c, b$).

The protocol for the new leader p_n in view $v + 1$ is:

-
- (10) Accept $2f + 1$ *view-change* messages(?) (possibly including p_n 's) in a *certificate-for-new-view* set V .
 - (11) Gather O , which is a set of *pre-prepare*(s, r, p_n) messages in view $v + 1$ for all pairs (s, p), where at least one *certificate for prepare* for (s, r) exists in V .
 - (12) Find s_{max} , which is the highest sequence number for which O contains a *pre-prepare* message.
 - (13) Add a message *pre-prepare*($s', null, p_n$) to O for every sequence number $s' < s_{max}$ for which O does not have a *pre-prepare* message.
 - (14) Send a *new-view* (V, O, p_n) message to all nodes and start processing requests for view $v + 1$ starting from sequence number $s_{max} + 1$.

After the new leader is elected, other backups b need to check if the newly elected leader is correct.

- (15) Upon receiving a *new-view* (V, O, p_n) , a backup follower stops accepting any messages from the previous view v , and sets its local view to $v + 1$.
- (16) Check if the *new-view* message is from the new leader, and check if O is correctly constructed from V . If yes, respond to all the *pre-prepare* messages in O just as in the last view v and start accepting messages from the current view $v + 1$. Otherwise, if the current leader is still faulty, trigger a new *view change* to $v + 2$.

Now we check how PBFT guarantees agreement for a unique sequence number during the view change phase.

LEMMA 3.2. (*PBFT: Agreement during view change*). *If a view change is triggered in view v and the new view is $v' > v$ in which the leader is correct, if a correct process executes a request r in v with sequence number s , then no correct process will execute any request $r' \neq r$ with sequence number s in v' .*

PROOF. If any correct node executed request r with sequence number s , there must be at least $2f + 1$ processes that have sent a *commit* message regarding (s, r) ; we denote them by the set S_1 (this is why a commit phase is required). The correct processes in S_1 must have all collected a *certificate-for-prepare*. When going through the view change phase, a *certificate-for-new-view* must contain *view-change* messages from at least $2f + 1$ processes, denoted by S_2 . Recall the notion of a quorum system and quorum intersection; S_1 and S_2 are two quorums which intersect with at least one correct process c_p . ($2 \times (2f + 1) - (3f + 1) = 1$). Therefore, there is at least one correct process $c_p \in S_1 \cap S_2$ that has collected a *certificate-for-prepare* regarding (s, r) and whose *view change* message is contained in V . Therefore, if some correct node executes request r with sequence s , then V must contain a *certificate-of-prepare* regarding (s, r) from c_p . Thus, a newly elected correct leader p_n sends a *new-view* (v', V, O, p_n) message where O contains a *pre-prepare* message for (s, r) in the new view v' . \square

Correct followers will enter the new view v' only when the *new-view* message for v' contains a valid *certificate-for-new-view* and O is constructed from V as introduced in step (16). They will then respond to the messages in O before they start accepting *pre-prepare* messages in v' , as introduced in step (16). Therefore, for any sequence numbers that are included in O , correct followers will only send *prepare* messages to respond to the *pre-prepare* messages in O . Consequently, in the new view v' , correct followers can only collect a *certificate-for-prepare* for (s, r) that appears in O , while for some (s, r') where $r' \neq r$, no process can collect a *certificate-for-prepare* because there is a lack of *pre-prepare* messages for r' (recall that in step (3), a *certificate-for-prepare* needs $2f$ *prepare* messages together with the *pre-prepare* message).

THEOREM 3.1. *PBFT guarantees a unique sequence number.*

PROOF. When PBFT is going through the normal case in which the leader is correct, by Lemma 3.1, PBFT guarantees a unique sequence number. When the leader is faulty and a view change is triggered, by Lemma 3.2, PBFT guarantees a unique sequence number through the view change phase. By combining these two lemmas, we obtain Theorem 3.1. \square

► **Remark.** We have shown that PBFT guarantees safety. Recall the notion introduced in Section 2.4, that is, as long as nothing bad happens, the correct processes always agree (never disagree) on requests that were committed with the same unique sequence number. It is important to be clear that PBFT is a total ordering protocol for SMR in which all correct processes agree on the unique sequence for different requests as a consecutive service; it is not a Byzantine agreement protocol in which every process has an initial value and all of them finally agree on the same value once. In addition, to achieve liveness, PBFT assumes that the message delays are finite and bounded, which indicates that the

network of PBFT is partially synchronous. In other words, in a completely asynchronous network, PBFT might have no progress at all. However, a partially synchronous network is sufficiently practical for deployment.

3.1.2 Quorum-based Total Ordering Solutions: Q/U and HQ.

Q/U [1] (Query/Update) points out that the PBFT protocol is not fault-scalable, i.e., its performance decreases rapidly as more faults are tolerated. Therefore, Q/U adopts another mechanism to achieve replication: the operations-based interface, which can achieve SMR in a similar manner (but different from the notion of SMR, as recalled in Section 2.4). Q/U has two kinds of operations: queries and updates. The former do not modify objects, but the latter do. To reduce message and communication complexity, Q/U shifts some tasks from replicas to the clients. Unlike PBFT, the clients in Q/U not only send the requests, but are also responsible for selecting the quorum, storing replica histories returned by servers, and dealing with contention. When performing operations on an object in Q/U, clients issue requests to a quorum of servers. If a server receives and accepts a request, it invokes a method on its local object replica. The servers do not directly exchange information as in PBFT. Each time a request is sent by a client, the client needs to retrieve the object history set. This set is an array of replica histories indexed by server and represents the client's partial observation of the global system state at some time point. Quorum intersection guarantees that for any client requests, there is at least one correct node that has the newest system state. Through client-server communication, replica histories are communicated between servers via the client; if some server does not receive some update requests (it is possible because each request is only sent to a quorum by the client), it synchronises the newest system state with the help of the client. In this way, system overhead is transferred from servers to clients.

Q/U also tolerates Byzantine failures (including clients and servers). If a server crashes, some quorums might be unavailable. Consequently, the clients need to find a live quorum to collect a quorum of responses. Cryptography techniques are used to limit the power of faulty components. No server can forge a newer system state that does not exist; the forged faulty information can be detected by any correct client. Therefore, from the perspective of a correct client, as long as enough correct servers exist, it can continue to make progress. If some replicas are not up to date, correct clients will help them reach the current state. If any faulty client only issues update requests to a subset of a quorum, correct clients will repair the consistency by updating correct servers to the current state in a quorum. In addition, any faulty client that fails to issue update requests to all nodes in a quorum can be detected by techniques like lazy verification [2]. The total order property is guaranteed by the quorum system and cryptography, i.e., at least one correct replica has the correct history due to quorum intersection. This is used in conjunction with a cryptography-based validation mechanism to prevent forged requests and ensure the system agrees on the same sequence for every update request (query requests do not influence system consistency). If contention occurs, correct clients are responsible for the repair operation. Q/U can tolerate up to $f < \frac{N}{5}$ faulty replicas.

In summary, Q/U relies on correct clients to make progress, which is leaderless that does not contain a leader to accept and forward clients' requests. The clients are responsible for selecting quorum, storing the history and prove the validity of its history, repairing inconsistency, solving contention, etc. This design reduce the overhead when some replicas are faulty because the correct clients only needs enough (a quorum) correct replicas' response, and no all-to-all communication between replicas is needed. However, this design also leads to the inability to batch clients' requests.

To summarise, Q/U relies on correct clients to make progress and is leaderless, meaning it does not contain a leader to accept and forward clients' requests. The clients are responsible for selecting quorum, storing the history, proving the validity of their history, repairing inconsistency, solving contention, etc. This design reduces the overhead when some

replicas are faulty because the correct clients only need enough (a quorum) correct replicas' responses, and no all-to-all communication between replicas is needed. However, this design also leads to the inability to batch clients' requests.

HQ [40] (Hybrid Quorum) argues that although Q/U has better performance with increasing faulty processes than PBFT, it needs more replicas ($5f + 1$) to tolerate faulty nodes than PBFT ($3f + 1$). In addition, when contention exists, Q/U performs poorly because it resorts to exponential back-off to resolve contention. Therefore, HQ proposes a hybrid quorum replication protocol. In the absence of contention, HQ uses a quorum protocol where reads (a.k.a. queries in Q/U) and writes (updates in Q/U) require different communication between clients and replicas. The read/write operations in HQ are similar to those in Q/U, in which the clients send requests to a quorum, but HQ adds an additional round to make two rounds for the write operation to tolerate $f < \frac{N}{3}$ faulty nodes. Similar to Q/U, the total order property is ensured by quorum intersection together with cryptography techniques. In HQ, *certificates* are used to ensure that write operations are properly ordered. Quorum intersection guarantees that at least some correct replicas have the newest state, and certificates are used to convince other replicas. When contention occurs, HQ utilises a BFT state machine replication protocol to reach agreement on a deterministic ordering of the conflicting requests. Hence, the total order property is always guaranteed as the system makes progress.

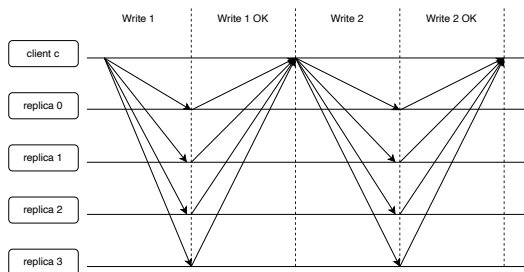

Fig. 3. Quorum-based solutions

► **Remark.** The quorum-based solutions reduce the overhead on replicas. These protocols require clients to execute more operations, which helps avoid excessive message communication between replicas, and thus improves performance in the existence of faulty replicas. These protocols rely on correct clients to ensure system progress. The drawback, however, is also caused by their leaderless design: the clients' requests cannot be batched because each client's request is also responsible for dealing with local state updates in replicas and repairing inconsistency through client-server communications. In addition, they do not have a leader funnelling all requests to other replicas. In summary, if accepting $5f + 1$ replicas, Q/U is the best choice; otherwise, if accepting $3f + 1$ replicas, HQ is the best with a batch size of 1. Otherwise, PBFT is the best option to outperform Q/U and HQ due to its ability to process requests in batches [40].

3.1.3 Leader-based Total Ordering with SMR design and Speculation: Zyzzyva.

In real applications, faults do not usually exist. Therefore, some practitioners hesitate to deploy BFT systems, partly due to the perception that BFT imposes high system overheads. Zyzzyva [93] is based on the SMR approach with a leader-based design, since quorum-based solutions cannot batch concurrent client requests, which limits throughput. Different from PBFT, which runs an expensive agreement protocol on the requests' deterministic final order before execution, Zyzzyva utilises *speculation* and immediately executes requests. The motivation for this is that, the possibility

of the existence of a failure is small in a real environment, and thus *Zyzyva* proposes to make fast progress based on the speculation that every node is working properly and only exchanges messages when faults exist.

A response from a replica not only contains an application-level reply, but also includes the history on which the reply depends. This allows the client to determine when a request has completed. A request completes in one of two ways. The first way is the fast case: if the client receives $3f + 1$ matching responses, it considers the request complete since all correct nodes must have responded to this request in this case. The second one is the two-phase case: if the number of received matching responses is between $2f + 1$ and $3f$, the client gathers $2f + 1$ matching responses and forms a *commit certificate*, which includes a cryptographic proof that $2f + 1$ replicas agree on a linearizable order of the request and all preceding requests. Due to quorum intersection, the commit certificate of $2f + 1$ replicas ensures that no other ordering can get $2f + 1$ matching responses to contradict this order. Once $2f + 1$ replicas acknowledge receiving the commit certificate, the client considers the request complete. Safety is also guaranteed through clients. A faulty client may alter the commit certificate or fail to send a commit certificate. The altered certificate will be detected and ignored by correct replicas with the property of cryptography. If a faulty client fails to deliver a commit certificate, it may not learn when its request completes, and a replica whose state has diverged from its peers may not discover the situation immediately. However, if in the future a correct client issues a request, it will either complete that request or trigger a view change if it finds an inconsistency (in the history of a response). If the view change is triggered, i.e., the inconsistency causes less than $2f + 1$ matching responses, the correct client will resend its request to all replicas, which then forward the request to the primary in order to ensure the request sequence guarantees the request is eventually executed. Additionally, all previous requests are delivered to every replica, and the request is completed. If the primary is faulty and a correct client receives responses indicating inconsistent ordering by the primary, it gathers a proof of misbehaviour and initiates a view change.

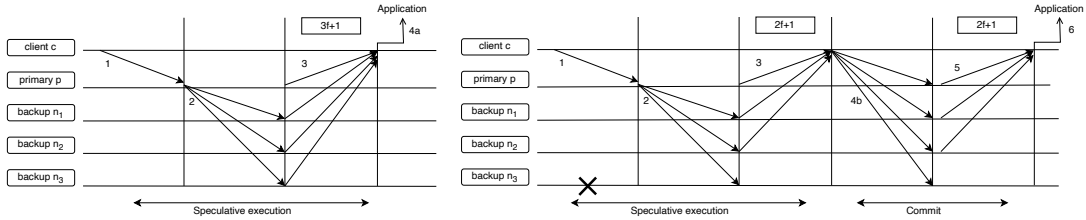

Fig. 4. *Zyzyva*: Fast case and two-step case

► **Remark.** *Zyzyva* follows the leader-based paradigm with an SMR design in which all replicas eventually execute the requests in the same order. It also utilises a similar idea to guarantee total ordering: it ensures a unique sequence within a view and through the view change, which guarantees a unique sequence through the system's execution. *Zyzyva* uses speculation to improve performance when the system is working properly, which is the case during most of the time. However, *Zyzyva* utilises heavy cryptography in the existence of a fault to ensure a unique sequence, which causes performance in the faulty case to drop sharply.

3.2 Make BFT Scaling: Parallel and Sharding/Partition-based BFT

BFT-SMR is considered slow as replicas need to agree on a global total order of client requests with the help of the leader node. It is identified in [7] that PBFT and other leader-based solutions could be attacked by the leader, i.e., the

leader might be maliciously smart and degrade system throughput while not being detected by follower replicas. Aublin [7] proposed a novel solution called Redundant BFT (RBFT), which executes $f + 1$ multiple BFT instances, where each instance has a different leader assigned to it at different machines. Every leader will order the requests, but only the requests ordered by the master leader will be executed. Multiple instances assigned to different leaders make them able to monitor the performance of the master leader. If the performance of the master leader is considered slow, a new master leader will be selected.

Parallel instances are not only used to monitor the performance of the leader, but also deployed to speed up system performance. In this kind of deployment, the motivation is to relax the requirement to execute the client requests following a deterministic sequence, i.e., these approaches usually run concurrent instances to execute non-overlapping requests [83, 94]. The core idea in CBASE [94] is to relax the order requirement on state machine replication to allow concurrent execution of independent requests without compromising safety. To accomplish this, the authors introduce a paralleliser that leverages application-specific rules to identify and execute concurrent requests in parallel. By doing so, the replicated system's throughput scales with both the level of parallelism exposed by the application and the available hardware resources. In comparison, Eve [83] uses a system-level approach. Their execute-verify approach uses a similar speculation improvement as Zyzzyva: replicas first speculatively execute requests concurrently, and then verify that they have agreed on the state and the output produced by a correct replica. If too many replicas diverge, Eve rolls back and re-executes the requests.

BFT has high client scalability, but it however suffers from low server scalability, i.e., BFT cannot scale to a large number of replicas. Two main streams of scalability solutions are proposed: hierarchical BFT and sharding/partition BFT. The idea of these two kinds of solutions follows the optimisation mechanism of reducing all-to-all messages, which is a common approach in distributed systems [20]. Hierarchical BFT protocols usually involve several phase(s) of BFT instances at different hierarchies [5, 6, 88, 151]. The representative example Steward [5] divides replicas into several groups, each group has $n > 3f + 1$ replicas. One group serves as the leader group, and will be changed by view change protocol if it is detected to be faulty. A client inside a group send requests to the representative node in this group if it is not in a leader group. The requests will be forwarded to the leader group and will be assigned a sequence number through PBFT in leader group. The order will be send back to all groups and finally every replica execute the requests with the same order. The core idea of Steward is each group is fault-tolerant and could be logically regarded as a replica therefore reduce all-to-all communication to enhance scalability.

BFT has high client scalability; however, it suffers from low server scalability, i.e., BFT cannot scale to a large number of replicas. Two main streams of scalability solutions are proposed: hierarchical BFT and sharding/partition BFT. The idea of these two kinds of solutions follows the optimisation mechanism of reducing all-to-all messages, which is a common approach in distributed systems [20]. Hierarchical BFT protocols usually involve several phase(s) of BFT instances at different hierarchies [5, 6, 88, 151]. The representative example Steward [5] divides replicas into several groups, where each group has $n > 3f + 1$ replicas. One group serves as the leader group, and will be changed by a view change protocol if it is detected to be faulty. A client inside a group sends requests to the representative node in its group if it is not in the leader group. The requests will be forwarded to the leader group and will be assigned a sequence number through PBFT in the leader group. The order will be sent back to all groups and finally every replica executes the requests in the same order. The core idea of Steward is that each group is fault-tolerant and could be logically regarded as a replica, thus reducing all-to-all communication to enhance scalability. It is worth noting that the fault-tolerant capacity is reduced in this pattern, as it requires each group to have $3f + 1$ replicas, which is essentially a more strict assumption than requiring the total system to have $3f + 1$ replicas. EZBFT [6] utilises a leaderless mechanism:

each replica can receive requests from clients and assign a sequence number to each request, then forward the requests to other replicas. Each replica has an instance space which contains all the sequence numbers it can assign to a request. The conflict is resolved at the client side: like Q/U and HQ, a request from a client not only contains the request itself, but also includes the dependencies of this request. The dependencies are used to identify if this request does not conflict with others (e.g., a read request) and can be executed immediately. If a request might have a conflict, replicas will execute it in sequence. In ME-BFT [151], the PBFT protocol is only deployed within a fixed number of full replicas, while other light replicas follow a full replica as a representative and rely on it to forward their requests to other full replicas. If a light replica detects that the full replica it relies on is faulty, it will change its representative.

The above design also follows the idea of reducing all-to-all communication overhead to achieve scaling, but the request data needs to be Conflict-free Replicated Data Types (CRDT)[133]. In [88], the authors design a novel protocol that replaces electing a leader with electing a random vector; combined with secret-sharing, the adversary needs to collude with more replicas to influence the system, and the possibility of this happening decreases with an increasing number of replicas. The messages sent by each replica are reduced from $O(n)$ to $O(\sqrt{n})$ to directly reduce communication overhead and achieve scaling. SBFT[71] also considers reducing communication complexity. In order to avoid complex all-to-all communication, SBFT assigns one or several nodes as collectors to collect a threshold signature and distribute the aggregated signature to every participant, which reduces the communication complexity from linear to constant. It also uses redundant servers for the fast path, similar to Zyzzyva; it allows a fast agreement protocol when all replicas are non-faulty.

Sharding/partition based BFT divides replicas into several partitions according to different application states to achieve scaling [16, 53, 104]. The core idea of these schemes is to improve performance by allowing write requests to be executed concurrently by different partitions. If write requests cause contention, i.e., different write operations access the same partition or a write request accesses multiple partitions [104], it needs to be resolved. When contentions need to be resolved frequently, the performance will degrade due to heavy conflict resolution procedures. Some solutions have been proposed to mitigate the conflict problem; for example, [74] designed a conflict-free sharding-based Byzantine-tolerant total ordering protocol. It first pre-executes cross-shard requests, then delegates a random shard to sequence the pre-executed requests for a global order based on prerequisite information. Cross-shard verification is used to verify the pre-execution result. Mir-BFT[138] is a BFT protocol that combines parallel and partition optimisation schemes. It uses parallel leaders to order clients' requests concurrently to handle scalability. To multiplex PBFT instances into a single total order, Mir-BFT also partitions the request hash space across replicas to prevent request duplication.

► **Remark.** Parallel and sharding/partition optimisation mechanisms generally consider reducing all-to-all messages[5, 71, 74, 88, 151] and increasing concurrency[6, 138, 151] to enhance server scalability. The overall structures follow the typical BFT-SMR paradigm with a leader and followers to execute requests in the same order to achieve the same state. Cryptography, such as threshold signatures, is used [71, 88] to reduce communication complexity; this works well in environments with powerful computation, such as blockchain systems, but might be a bottleneck for computation-restrained environments such as wireless [25, 154]. In addition, in some parallel BFT protocols, the fault model has also been changed. For instance, in [5], it is assumed that each group of n replicas is fault tolerant and has up to $\lfloor \frac{n-1}{3} \rfloor$ faulty replicas, which is different from (in essential a harsher assumption than) assuming the whole system has up to one-third faulty nodes.

3.3 The Power of Trusted Component: Trusted Execution Environment-based BFT

In the early years (c.f.2.3.2), Bracha’s asynchronous reliable broadcast[17] techniques to restrict Byzantine nodes’ behaviour to a crash failure mode. However, Bracha’s reliable broadcast and related solutions that restrict Byzantine nodes’ ability rely on message passing, which could result in high communication overhead. The use of a trusted execution environment (TEE) shares a similar motivation: to shift tasks from replica software (i.e., communication) to special trusted hardware in order to restrict the power of a faulty node.

Recall that in Section 2.2, we introduced three mechanisms to bypass the FLP impossibility: loosening the asynchrony assumption (e.g., PBFT), utilising randomness (e.g., Ben-Or’s randomised algorithm), and adding detectors or oracles. Correia et al.’s solution[36] employs the third mechanism; it relies on an oracle to circumvent FLP and increase resilience. Correia et al. extend the asynchronous system with an oracle called the Trusted Timely Computing Base (TTCB). The TTCB is a real-time, synchronous subsystem capable of timely behaviour and provides a small set of basic security services to achieve intrusion tolerance [38]. It could be implemented on RTAI [35], which is protected by hardening the kernel. Based on TTCB, the authors proposed a Trusted Multicast Ordering (TMO) service . TMO is implemented in TTCB, making it secure against malicious attacks ; thus, only crash faults exist . The messages are passed through the payload network, which is assumed to be asynchronous but reliable, meaning that the messages will not be altered and will eventually be received. In addition, messages are verified by Message Authentication Codes (MACs) to protect their integrity. The TMO service assigns a unique sequence number to each request, and the messages of TMO are passed through the TTCB control channel, which is reliable and synchronous. The whole procedure is as follows: when a process calls a *send* or *receive* operation in its local TTCB, information about this call is broadcasted to everyone. If the processes acknowledging this operation (by sending a cryptographic hash digest of this request to the coordinator, which is also a local TTCB service) reach the threshold of $\lfloor \frac{n-1}{2} \rfloor$, the coordinator will assign a sequence number to the operation. Other nodes can obtain this sequence number through the TTCB channel. If the coordinator crashes (as previously mentioned, no malicious faults exist), another coordinator will take over . This is possible because the other coordinator is aware of the broadcast made by the crashed coordinator through the reliable channel.

Correia et al.’s work achieves SMR for several reasons. Recall the definition of atomic broadcast in Definition 2.11: validity is guaranteed by the reliable payload network; agreement is achieved by the reliable payload network and the TMO service, as a sequence number is only assigned to a request when the number of correct processes reaches a threshold; integrity is guaranteed by the reliable payload channel, the TTCB control channel, and MACs; and total order is provided by the TMO. Therefore, Correia et al.’s scheme achieves atomic broadcast (a.k.a. total order broadcast), which can be used to build an SMR if all processes started with the same initial state.

Similar to TMO, which restrains the power of malicious nodes, A2M [32] introduces Attested Append-Only Memory. This memory pool equips a host with a set of trusted, undeniable, ordered logs, which only provide *append*, *lookup*, *end*, *truncate*, and *advance* operation interfaces and has no method to replace values that have already been assigned (a sequence number). In implementation, A2M could be a trusted virtual machine, trusted hardware, etc. A2M can be integrated into various BFT protocols, including PBFT and Q/U. For instance, in the A2M-integrated PBFT protocol, A2M-PBFT-EA, every message needs to be inserted into the corresponding message memory (i.e., the *Pre-Prepare message memory pool*). With the help of A2M, no equivocation exists, i.e., every replica is forced to send consistent messages to others. Therefore, when utilizing the same flow as PBFT, A2M-PBFT-EA only needs $2f + 1$ replicas to tolerate f Byzantine faulty nodes.

TMO and A2M prove that by deploying tamper-proof components to extend the server in SMR, one can reduce the number of replicas from $3f + 1$ to $2f + 1$. However, TMO and A2M are both locally installed services on each computer (server), instead of being distributed deployments. To tackle this problem, MinBFT and MinZyzyva were proposed by Veronese et al. [142]. They designed a local service called the *Unique Sequential Identifier Generator* (USIG). Its function is to assign a counter value to each message. USIG guarantees three properties even if the replica becomes faulty: (1) It will never assign the same identifier to two different messages; (2) It will never assign an identifier lower than a previous one; and (3) It will always attribute a sequential identifier. USIG can be built on public-key cryptography, and it needs to be deployed on an isolated, tamper-proof component that is assumed to be incorruptible. As reviewed in Section 3.1.1, we analysed how the *prepare* and *pre-prepare* phases guarantee a unique sequence within a view. In MinPBFT, the unique sequence is guaranteed by USIG, so the *pre-prepare* phase is not needed. The flow is similar to PBFT: the client first sends a *request* message to all replicas, then the leader obtains a sequence number from USIG and broadcasts a *prepare* message to all replicas. After receiving the *prepare* message, a replica verifies whether the message and sequence are valid, and broadcasts a *commit* message if the verification passes. When a replica receives $f + 1$ valid *commit* messages, it accepts the request and sends a *reply* after execution. If the leader is faulty and a *view change* is triggered, replicas stop receiving messages, obtain a unique identifier from USIG for the *view change* message, and then start to listen to the new leader if it is correct. Similar to PBFT, all requests since the last checkpoint will be stored in a new view certificate of the new leader to be broadcast to every replica, and requests will be executed starting from the latest one. However, unlike in PBFT, the unique sequence is not guaranteed by a quorum as proven in Lemma 3.2, but rather is assigned by the USIG. MinZyzyva is designed in a similar way, following the flow of Zyzyva, and is not described repeatedly.

Based on the idea of MinBFT, CheapBFT [82] was proposed as an optimisation of MinBFT. Similar to MinBFT, CheapBFT also relies on a trusted component named the Counter Assignment Service in Hardware (CASH) to manage a monotonically increasing counter, and guarantee node identity and message authentication. By utilising CASH, no equivocation exists. In the normal case when no faults exist, CheapBFT utilises an optimised flow where only $f + 1$ ($f = \lfloor \frac{n-1}{2} \rfloor$) nodes act as active replicas that send and receive *prepare* and *commit* messages. Passive replicas only need to listen to *update* messages that include the execution result and the commit certificate. When a fault is detected or the system fails to reach agreement, CheapBFT falls back to MinBFT to achieve correctness.

► **Remark.** TEE-based approaches can enhance the resilience and performance of BFT protocols as well as simplify them. By utilizing trusted components, the power of malicious participants is restricted. Achieving non-equivocation is a core design goal of TEE-based BFT protocols. The power of non-equivocation is introduced in [34]; combined with the transferable authentication of messages in the network, e.g., digital signatures, it is possible to use non-equivocation to transform CFT protocols to tolerate Byzantine faults. In these TEE-based works [32, 36, 82, 142], the cost of fault-tolerance is reduced from $3f + 1$ to $2f + 1$. [32, 36] use local trusted components, which means replicas should be physically connected. [82, 142] use a similar flow as PBFT such that they can be deployed in a distributed manner. However, the trusted environment itself is a challenge and a drawback, as the trusted components themselves are required to participate in the protocols. In addition, since all known TEEs have vulnerabilities [27, 56], the protocols should not rely on the trusted components to make progress.

3.4 Partially Synchronous BFT for Blockchain

Blockchain is essentially a form of SMR. The fast development of blockchain has triggered research interest in traditional SMR and consensus protocols. However, blockchain has different requirements and challenges than traditional SMR and

consensus. One simple difference is that in a blockchain system, computational power is much cheaper than in general distributed systems, so more complex cryptographic techniques can be used. Another difference is that blockchain requires ‘fairness’ and chain quality [67], which necessitates regular leader rotation, while in SMR there is no need to change a leader if it is working properly. In addition, blockchain has a higher demand for scaling because the number of participants is generally larger than in traditional SMR.

3.4.1 Tendermint: BFT in Blockchain arena with Voting Power.

Tendermint [19] is a PBFT-like consensus mechanism designed for the blockchain context. Similar to PBFT, it assumes a partially synchronous network model in which the communication delay is bounded. However, Tendermint identifies several different requirements for blockchain compared to standard SMR. First, in the consensus mechanisms like PBFT, the value for a decision that every correct process considers acceptable is not just the value sent by someone, but a set of $2f + 1$ messages with the same value ID. Therefore, each message can be regarded as an “endorsement” or “vote” for a value. In blockchain, each participant has a different amount of voting power. This makes the scenario different from traditional SMR, where voting power in SMR is completely identical, with each message having an identical weight. It can also be challenging to scale, as the total number of messages being sent in traditional SMR depends on the total number of processes. To address this issue, in Tendermint, the $2f + 1$ quorum intersection is replaced by $2f + 1$ voting power, with the total system voting power being divided into $N = 3f + 1$. Another difference is that in PBFT, the requests from clients will be executed, but in Tendermint, any transaction in the proposed block needs application-level validity verification. In Tendermint, one or more proposer(s) will propose a block until a majority ($2N/3$) of voting power approves it, and the block will be solidified through several rounds of communication involving voting, corresponding to several rounds of message passing in PBFT.

3.4.2 Algorand: Byzantine Agreement with VRF and Common Coin.

Unlike most BFT blockchains that generally operate in a permissioned network, Algorand [68] tries to design a BFT protocol that can be used for the deployment of a permissionless blockchain. They argue that a permissionless blockchain requires “fairness”, which indicates that a participant with a higher balance amount should be more likely to be elected. Therefore, the authors invented a cryptographic sortition scheme using a VRF to secretly elect some participants based on priority (which is positively correlated with their balance amount) as the committee to validate the block sent by the proposer (which has the highest priority). Either only one of the proposed blocks or an empty block should be approved. Because the committee members change each round, and the value that needs to be approved is not a sequence number or an order, but a block, the authors propose using Byzantine Agreement (Definition 2.2) to reach agreement on the block. The procedure of the proposed Byzantine agreement protocol is voting-based. Once a proposed block receives a voting threshold, it is approved. Recall that Byzantine Agreement is a synchronous protocol, as introduced in 2.1, and its “validity” property requires that all correct nodes have the same initial value (a.k.a. all-same validity).

The author clearly states that the best-case scenario happens when the network is under strong synchrony and only a same block was sent to everyone by the proposer, and in this scenario Byzantine agreement protocol directly reaches *final* consensus. If a worse-case scenario happens, either in an asynchronous network or the proposer is malicious, binary agreement is used to decide if the decision is one of the proposed blocks or an empty block. Intuitively, the decision of a binary consensus is simply from $\{0, 1\}$. 1 represents one selected block, and 0 is an empty block. The selection scheme follows: when the proposer proposes different blocks and sends them to others, but one of them receives enough votes will be chosen, or simply one of the proposed blocks is selected if none of them receives enough votes. Recall that in section 2.3.1, Ben-Or’s randomised binary consensus can reach consensus with the probability of 1,

although it could be slow, but a shared coin (common coin) can significantly boost the consensus. In Algorand, the authors apply a randomised binary consensus with the deployment of common coin. The common coin is calculated by the “hash” produced by VRF which has the least priority. If the committee that yields *hash* is honest, all correct participants will observe the same coin and terminate fast. The probability for each loop that the committee is honest exceeds $\frac{2}{3}$ due to the utilisation of VRF. In addition, even if this committee is malicious, binary consensus will terminate with the probability of 1 anyway with more loops to be executed.

The authors state that the best-case scenario happens when the network is under strong synchrony and only the same block is sent to everyone by the proposer; in this scenario, the Byzantine agreement protocol directly reaches a *final* consensus. If a worst-case scenario occurs, either in an asynchronous network or when the proposer is malicious, binary agreement is used to decide if the decision is one of the proposed blocks or an empty block. Intuitively, the decision of a binary consensus is simply from 0, 1, where 1 represents one selected block, and 0 is an empty block. The selection scheme is as follows: when the proposer proposes different blocks and sends them to others, the block that receives enough votes will be chosen; otherwise, one of the proposed blocks is selected if none of them receives enough votes. Recall that in Section 2.3.1, Ben-Or’s randomised binary consensus can reach consensus with a probability of 1, although it may be slow, but a shared coin (common coin) can significantly boost the consensus. In Algorand, the authors apply a randomised binary consensus with the deployment of a common coin. The common coin is calculated by the “hash” produced by the VRF output. If the committee that yields the *hash* is honest, all correct participants will observe the same coin and terminate fast. The probability for each loop that the committee is honest exceeds $\frac{2}{3}$ due to the use of the VRF. In addition, even if this committee is malicious, binary consensus will terminate with a probability of 1 regardless, but more loops will need to be executed.

3.4.3 HotStuff: BFT with Quorum Certificate and Frequent View Change.

In blockchain, there is sufficient calculation power available for cryptographic mechanisms, and the leader node needs to be frequently rotated to ensure chain quality [67]. Therefore, HotStuff [156] was proposed to utilize a cryptographic threshold signature scheme to reduce authenticator complexity, which refers to the number of authenticators a replica must reach to make a consensus decision. Similar to PBFT, HotStuff is a leader-based SMR protocol which includes several phases, namely *prepare*, *pre-commit*, and *commit*. The core idea of HotStuff is also *quorum intersection*, but it uses a *Quorum Certificate (QC)* instead of a quorum of messages as in PBFT. A QC is essentially a certificate that is signed by a sufficient number of (i.e., $n - f$) replicas to demonstrate their agreement on a *view*; each view corresponds to a unique QC. Another difference is that *view change* is triggered after reaching a consensus decision each time, to address the demand for fairness in blockchain.

HotStuff is similar to PBFT in that it does not require synchrony for safety but does for liveness. Each replica stores a tree of pending commands as a local data structure. The commands are linked by *parent links*. As a tree structure, the command tree can fork, just like a fork in Bitcoin. A *branch* led by a given tree node is the path from this node all the way back to the tree root following *parent links*. Only one branch will be chosen during each round of the decision process. The main procedure is as follows:

- (1) Prepare Phase: For each *new view*, a leader will be elected by a certain scheme known to everyone, and each replica sends a *new view* message that carries the highest *prepareQC* from the last view, which records the last branch that received $n - f$ votes.

- (a) The leader will find the one with the highest view, namely *highQC*, and choose a branch that extends from the tail of the last QC, i.e., choosing a new leaf node from the command tree. The selected leaf, together with the *highQC*, will be embedded into a *prepare* message as the current proposal *curProposal* and sent to the replicas.
- (b) Once a replica receives the *prepare* message, it performs a *safeNode* predicate to verify if the *prepare* message is acceptable. The *safeNode* predicate has two rules. One is to check if the proposed leaf node directly extends from a previously decided node; if so, the replica is synchronised with the leader and no gap exists. The other rule is to check if its current view of *lockedQC* is smaller than that of the *prepare* message; if so, the replica might be stuck at a previous view and should try to synchronise with the leader. If *safeNode* predicate returns true, the replica accepts the prepare message.
- (2) Pre-Commit Phase: Once the leader receives $n - f$ *prepare* votes for *curProposal*, it combines them into a *prepareQC* for the current view. Then, the leader broadcasts the *prepareQC* in a *pre-commit* message. Replicas will respond to the leader with a vote for *pre-commit* along with their signature for the proposal.
- (3) Commit Phase: Similar to the Pre-Commit Phase, when the leader receives $n - f$ *pre-commit* votes, it combines them into a *precommitQC* and broadcasts them in the *commit* messages. Then, replicas respond with *commit* votes. At this point, a replica becomes locked on this *precommitQC* and sets *lockedQC* to *precommitQC*.
- (4) Commit Phase: Once the leader receives $n - f$ *commit* votes, it combines them into a *commitQC* and sends it with the *decide* messages to all replicas. After receiving *decide* messages, a replica considers the proposal in the *commitQC* a committed decision and executes the commands in the committed branch. Then, every replica starts the next view.

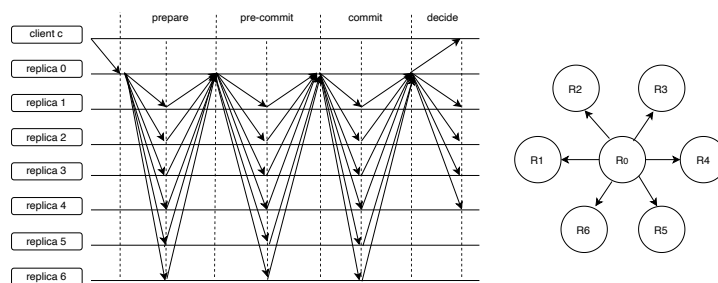

Fig. 5. Communication pattern and topology of HotStuff

The communication pattern with seven processes and the topology are illustrated in Fig. 5. The topology is a star-topology where the leader disseminates and aggregates information from others. In the whole procedure, three kinds of QC exist: *prepareQC*, *lockedQC* (equal to *precommitQC*), and *commitQC*. Readers might be curious about the second one: why do we need *lockedQC*? This question is similar to the question of “why is the *commit* message needed” in PBFT. Remember, the answer for PBFT is that the *commit* message is for ensuring the safety of a unique sequence during a “cross view” transition. Similarly, *lockedQC* is for safety during a “cross view” transition in the command tree. As introduced, the command tree forks, and only one branch will be selected. Therefore, to achieve safety, HotStuff needs to ensure:

If w and b are conflicting nodes, i.e., w and b are on two different branches where none of the branches is an extension of the other, they cannot both be committed, each by a correct replica.

As shown in Fig.6, if w and b are at the same view, for example, both at v_1 in Fig.6, it is obvious that they will not be committed simultaneously, as each commit needs $n - f = 2f + 1$ votes from correct nodes (comparable to the unique sequence within a view in PBFT). If w and b are at different views, as illustrated in the figure (v_1 and v_2 , respectively), we will show how *lockedQC* protects safety.

We assume w is at v_1 and b is at v_2 . s is a node that is the lowest node higher than w and conflicts with w . s comes with a valid *prepareQC* which is at v_s . qc_1 and qc_2 are valid *commitQCs*, and qc_s is a valid *prepareQC*. We already know that a *commitQC* is composed of $n - f$ *lockedQCs*, and a *prepareQC* needs to pass *safeNode* checks by $n - f$ replicas. If w and b are both committed, w and s are also both committed. Therefore, the intersection of *commitQC* and *prepareQC* is $n - f$ *lockedQCs* and $n - f$ *safeNode* predicates, $2 \times (n - f) - (3f + 1) = f + 1$, which has at least $f + 1 - f = 1$ correct replica r that updates *lockedQC* to *precommitQC* (i.e., qc_1) at view v_1 . As for *safeNode*, as w and s are conflicting, the first rule in *safeNode* cannot be matched. For the second rule, it is impossible for the correct replica r to have a *lockedQC* view smaller than qc_1 because it has already updated its *lockedQC* to *precommitQC*, which is exactly qc_1 ; hence, $n - f$ *safeNode* predicates can never be gathered, which is a contradiction. Therefore, safety during a cross view" transition is achieved with the help of *lockedQC*, just like with the *commit*" messages in PBFT.

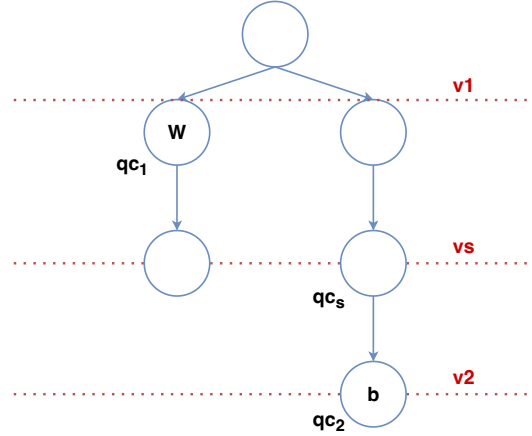

Fig. 6. Safety for conflicting nodes

► **Remark.** Partially synchronous BFT protocols have been improved for blockchain scenarios. Although blockchain is essentially an SMR system, it has different requirements from traditional SMR. The proposed blockchain-oriented BFT schemes are inspired by traditional agreement and consensus protocols. Tendermint applies quorum intersection but uses voting power instead of the message count. Algorand combines Byzantine agreement and binary consensus with a common coin, which originate from the Byzantine Generals Problem and Ben-Or's randomised consensus. HotStuff uses a Quorum Certificate, a cryptographic scheme to reduce messages, and is inspired by PBFT's quorum intersection principle to guarantee safety within a view and across different views.

4 PRACTICAL BFT IN FULLY ASYNCHRONOUS NETWORK

The FLP impossibility theorem [61] states that in an asynchronous environment, even if only one failure exists, a consensus protocol might never be able to achieve correctness. Intuitively speaking, partially synchronous and

synchronous protocols might achieve zero throughput against an adversarial asynchronous network scheduler [144]. This is why although partially synchronous protocols like PBFT and HotStuff do not need synchrony for safety, they require partial synchrony and GST for liveness. Thanks to the findings by Ben-Or [13], we know that randomised asynchronous protocols solve this problem by using a probabilistic approach to ensure that the protocol terminates with a probability of 1. These protocols usually involve a common coin to boost termination speed, which can be collectively generated using threshold cryptography [43] and VRF [112]. Asynchronous consensus is considered to be more robust than partially synchronous consensus in the presence of timing and denial-of-service (DoS) attacks, making them appropriate solutions for mission-critical distributed applications and blockchain systems. Before digging into asynchronous consensus protocols, we first introduce the technical components that can be utilised.

4.1 Building Atomic Broadcast on Binary Agreement and Multi-Valued Byzantine Agreement

In this section, we give a brief overview of how to build an atomic broadcast protocol on top of vector consensus and multi-valued consensus, which can eventually be reduced to binary consensus. Note that atomic broadcast is equal to SMR, which we have introduced in Section 2.4. In addition, there are no timing assumptions on atomic broadcast, which makes it asynchronous.

DEFINITION 4.1. *(Asynchronous) Binary Agreement (ABA) performs consensus on a binary value $v \in \{0,1\}$. It satisfies the following properties:*

- **Validity:** *If all correct processes propose the same value v , then any correct process decides on v .*
- **Agreement:** *No two correct processes decide on different values.*
- **Termination:** *Every correct process eventually decides.*

Note that Ben-Or’s randomised consensus is a typical binary agreement, meaning binary agreement can work in a fully asynchronous network. Note that all of the following ABA schemes utilise the common coin technique to boost termination.

DEFINITION 4.2. *Multi-Valued Consensus (a.k.a. Multi-Valued Byzantine Agreement, MVBA) performs consensus on a value $v \in \mathcal{V}$ with arbitrary length, where v can be a value proposed by some process in a domain \mathcal{V} or a default value $\perp \notin \mathcal{V}$ in case correct processes fail to propose the same value. The following properties are satisfied:*

- **All-Same Validity:** *If all correct processes propose the same value v , then any correct process decides on v .*
- **Validity1:** *If a correct process decides on v , then v was proposed by some process or $v = \perp$.*
- **Validity2:** *If no correct process ever proposed v , then no correct process will decide on v .*
- **Agreement:** *No two correct processes decide on different values.*
- **Termination:** *Every correct process eventually decides.*

Correia et al. [37] showed that an asynchronous multi-valued consensus could be built on top of binary consensus. The main procedure of the protocol for each process p_i is:

- (1) **(Asynchronously) reliable broadcast** its initial value and wait until $2f + 1$ initial values have been delivered. The received values will be stored in a vector V_i . Note that **reliable broadcast** guarantees that two processes will not receive different values from the same sender process, but the vectors might be different for each process because the first $2f + 1$ initial values do not have to be the same.

- (2) If in the vector V_i there are at least $f + 1$ instances of the same v value in the $2f + 1$ initial values received previously, then p_i sets $w = v$ and broadcasts w together with V_i . Otherwise, p_i selects \perp and also broadcasts it with V_i .
- (3) If p_i does not receive two different values $w \neq w'$ broadcasted in the last step, and it receives at least $f + 1$ messages with the same w , then it proposes 1 for the next **binary consensus**; otherwise, it proposes 0.
- (4) If the **binary consensus** decides on 0, then the multi-valued consensus returns \perp . Otherwise, p_i **waits** for $(f + 1)$ messages with w in case it has not already received them.

After the multi-valued consensus is built on top of binary consensus, we consider building vector consensus on top of multi-valued consensus. The goal of vector consensus is to reach agreement on a vector containing a subset of proposed values. In a Byzantine system, vector consensus is useful only if a majority of its values are proposed by correct processes. Therefore, the decided vector must have at least $2f + 1$ values. Vector consensus is similar to **interactive consistency** in a synchronous environment, which also reaches agreement on a vector. The difference is that interactive consistency reaches agreement on a vector with the values proposed by all correct processes, while vector consensus only guarantees that majority of the values are proposed by correct processes. The reason is that in an asynchronous network, it is impossible to ensure that a vector has the proposals of all correct processes due to the possibility of arbitrary delays. Remember that FLP states that one can never distinguish whether a message is lost or delayed in an asynchronous network.

DEFINITION 4.3. **Vector Consensus** performs consensus on a vector containing a subset of proposed values, which satisfies the following properties:

- **Vector Validity:** For every correct process that decides on a vector vec of size n ,
 - $\forall p_i$, if p_i is correct, then either $vec[i]$ is the value proposed by p_i or \perp .
 - At least $f + 1$ elements in vec are proposed by correct processes.
- **Agreement:** No two correct processes decide on different vectors.
- **Termination:** Every correct process eventually decides.

Correia et al. [37] implemented the **vector consensus** on top of **multi-valued consensus** using the following steps:

- Every process p_i sets $r_i = 0$ and **reliable broadcasts** an initial message $\langle in_msg_i, v_i \rangle$ with initial value v_i .
- p_i waits until at least $2f + 1 + r_i$ in_msg messages have been delivered. If $\langle in_msg_j, v_j \rangle$ is delivered, p_i sets $vec_i[j] = v_j$, otherwise it sets $vec_i[j] = \perp$.
- p_i calls **multi-valued consensus** with vec_i as the input and repeats this step until it returns a value other than \perp ; if \perp is returned, p_i increments r_i by 1 and goes back to the second step to wait for more in_msg messages.

Note that when **vector consensus** repeats the second step, it does not re-start the second step but rather waits until the required number of messages has cumulatively been received since the beginning. As in_msg messages are **reliable broadcasted**, all correct processes will eventually receive the same in_msg messages and build an identical vec . When enough processes propose the same vec to **multi-valued consensus**, vec will be decided, and then **vector consensus** immediately decides. Once **vector consensus** is implemented, **atomic broadcast** can be built on top of it. Recall the definition of **atomic broadcast** (definition 2.11) and **reliable broadcast** (definition 2.9), and **atomic broadcast** can be seen as **reliable broadcast** plus the *integrity* and *total order* properties. We can utilize a Secure Hash Digest function [59] to achieve *integrity*, thanks to the properties of a secure hash function. Then, we only need to guarantee the order of all delivered messages to implement **atomic broadcast**.

Correia et al. [37] give their solution for building **atomic broadcast** on top of **vector consensus**. The protocol is as follows:

- (1) First, use a Hash function to guarantee that if a malicious process tries to call reliable broadcast twice with the same message, reliable broadcast delivers the message only once. Once a message is delivered to a process by reliable broadcast, the process adds it to a message pool $R_delivered$, which is initially \emptyset . Note that each message in an atomic broadcast is assigned a unique sequence number.
- (2) When $R_delivered \neq \emptyset$, p_i sets a vector H_i =Hashes of the messages in $R_delivered$. Then, the H vector from each process is sent to the vector consensus protocol. The vector consensus protocol decides on a vector X_i after receiving at least $2f + 1$ H vectors from different processes, where X_i is a vector containing different H vectors as elements.
- (3) After receiving X_i , every process p_i waits for all messages M whose $Hash(M)$ is in at least $f + 1$ cells in X_i , where a cell is an element of an H vector. Then, p_i adds these messages to a message pool $A_deliver_i$.
- (4) p_i atomically delivers $A_deliver_i$ messages in a deterministic order for each message. Then, p_i removes $A_deliver_i$ messages from $R_deliver_i$.

How does this atomic broadcast work? W.l.o.g., we consider one message M in $R_deliver_i$ to be atomically broadcasted. Because reliable broadcast is used, it is guaranteed that in some execution, the hash $Hash(M)$ will be put in H vectors by all correct processes, and the vector consensus protocol will decide on a vector X_i that includes at least $f + 1$ entries with $Hash(M)$, since X_i has at least $2f + 1$ elements and there are at most f malicious processes. Therefore, $Hash(M)$ will be added to $A_deliver_i$, and M will be delivered by every correct process. To ensure the total order property, note that before each atomic broadcast decides, an execution of the vector consensus protocol is done, and each vector consensus instance is identified by a unique sequence number assigned to each atomic broadcast. Each vector consensus instance decides on a value only when a sufficient number of processes (at least $2f + 1$) propose the same vector; it is impossible for a different vector to be decided because there cannot be $2 \times (2f + 1)$ processes in total. Because each vector consensus instance terminates in the same order, each atomic broadcast instance will decide in the same order. Combined with the deterministic order of messages within one atomic broadcast instance, the total order of each message is guaranteed.

► **Remark.** Atomic broadcast could also be directly built on top of MVBA, but the properties of vector consensus would be realized nonetheless. We have shown that atomic broadcast can be built on top of vector consensus and multi-valued consensus, which can in turn be implemented on top of binary consensus. Readers can refer to [37] for the complete protocol and proofs. Although [37] might not be practical due to its complexity and latency, it demonstrates that asynchronous consensus primitives can be reduced from one level to another, which can finally be reduced to the level of asynchronous binary consensus.

4.2 Building Atomic Broadcast on Binary Agreement and Asynchronous Common Subset

The asynchronous common subset (ACS) is arguably one of the most practical frameworks for asynchronous BFT. ACS was first proposed by Ben-Or et al.[14], and recently made practical by HoneyBadgerBFT[113] and BEAT [50].

DEFINITION 4.4. *textbfAsynchronous Common Subset (ACS) assumes a setting with a dynamic predicate Q that assigns a binary value to each process, and ensures that a correct process i will (eventually) be assigned the value $Q(i) = 1$. Every process is guaranteed to agree on a subset of at least $2f + 1$ processes for whom $Q(i) = 1$. ACS satisfies:*

- **Validity:** If a correct process p_i outputs a set $SubSet_i$, then $|SubSet_i| \geq 2f + 1$ and $SubSet_i$ contains the input of at least $f + 1$ correct processes.
- **Agreement:** If a correct process outputs $SubSet$, then every node outputs $SubSet$.
- **Totality:** If $2f + 1$ correct processes receive an input, then all correct processes produce an output.

The original ACS protocol by Ben-Or [14] is quite simple. We now give a brief description.

-
- (0) Execute an ABA for each process to determine whether it will be in the agreed set.
 - (1) For process p_i , participate in ABA_j with input 1 for each p_j for which p_i knows $Q(j) = 1$.
 - (2) Upon completing $2f + 1$ ABA protocols with output 1, enter input 0 to all ABA protocols for which p_i has not yet entered a value.
 - (3) Upon completing all n ABA protocols, output $SubSet_i$ which is the set of all indices j for which ABA_j had output 1.
-

Ben-Or's ACS was designed for multiparty computations. Miller et al. adapted it for use in asynchronous BFT protocols in HoneyBadgerBFT [113]. HoneyBadgerBFT's ACS uses the same n -ABA parallel execution as Ben-Or's ACS, but makes an adjustment to the predicate Q . HoneyBadgerBFT's ACS adds a RBC phase before ACS. For each process i , it first inputs value v_i to RBC_i . Upon delivery of v_j from RBC_j , if input has not yet been provided to ABA_j , then it provides input 1 to ABA_j . After that, the procedure is identical to Ben-Or's ACS. In other words, the predicate is implemented by RBC. After the $SubSet_i$ is output, i.e., all instances of ABA have completed, p_i waits for v_j from RBC_j such that $j \in SubSet_i$.

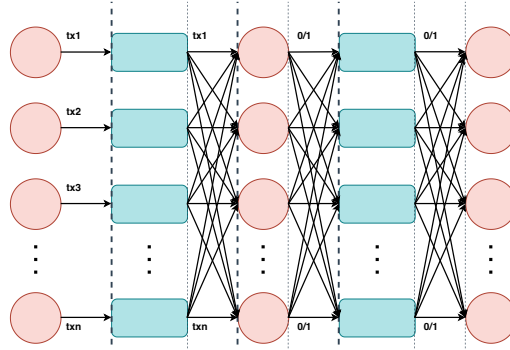

Fig. 7. ACS of HoneyBadgerBFT

HoneyBadgerBFT's ACS solution executes n RBC and n ABA in parallel. In the RBC phase, each process broadcasts its value; in the ABA phase, the i -th ABA is used to agree on whether p_i 's value has been delivered in the RBC phase. Once the $SubSet$ is output by ACS, every process will be aware of whose value is already determined to be accepted by BA, and will wait for these values to be delivered by RBC. The RBC guarantees these values will eventually arrive, so every process can build the same vector vec that contains all these values. Therefore, an atomic broadcast can be achieved by having every process input its value to RBC and delivering values in vec in a deterministic sequence.

► **Remark.** ACS and MVBA are two frameworks for implementing asynchronous atomic broadcast. Both ACS and MVBA can be built on ABA. Note that the atomic broadcast built on MVBA could be used for a scenario in which, during a specific time period, only a small subset of processes (e.g., one or two) are broadcasting, because there is

no assumption on how many processes trigger RBC. However, for ACS in HoneyBadgerBFT, there is a requirement that n processes propose values in parallel, and each correct process must propose something during the RBC phase, as illustrated in Fig.7 (otherwise, for example, if only a small number of processes trigger RBC, step (2) in ACS that requires $2f + 1$ ABA with output 1 will never be satisfied). Intuitively, HoneyBadgerBFT's ACS is suitable for the "batch" settings, particularly in blockchain scenarios. In addition, the complexity of these two protocols is different, and MVBA is considered less efficient than ACS in blockchain scenarios[113]. Since we focus on how these BFT protocols work, we do not delve into the details in this paper.

4.3 Asynchronous BFT for Blockchain

Recent research trends on asynchronous BFT problems are also driven by the surprising success and development of cryptocurrencies and blockchains. The motivation for implementing asynchronous BFT protocols in blockchains instead of partially asynchronous protocols is that conventional wisdom, like PBFT and its variations, rely critically on network timing assumptions, and only guarantee liveness after GST, which is considered ill-suited for the blockchain scenario as blockchain systems face a much stronger adversary [113].

4.3.1 HoneyBadgerBFT: An ACS-based Practical Asynchronous BFT for Blockchain.

As an optimisation for cryptocurrency and blockchain scenarios, HoneyBadgerBFT considers network bandwidth to be the scarce resource but computation to be relatively ample. Therefore, HoneyBadgerBFT could take advantage of cryptography that is considered expensive in classical fault-tolerant settings.

The authors first argue that an adversary could thwart PBFT and its variations. In PBFT, the designated leader is responsible for proposing the next batch of transactions at any given time, and if progress isn't made, either due to a faulty leader or a stalled network, the nodes attempt to elect a new leader. Because PBFT relies on a partially asynchronous network for liveness, one can construct an adversarial network scheduler that violates this assumption, resulting in PBFT making no progress at all. For example, when a single node has crashed, the network scheduler delays messages from all the newly elected correct leaders to prevent progress until the crashed node is the next one to be elected as the leader, then the scheduler immediately heals the network and delivers messages very rapidly among correct nodes. However, as the next leader has crashed, no progress is made in this case. In addition, any partially synchronous protocols that rely on timeouts have the problem that they are very slow when recovering from network partitions, because the delay assumption and timeout implementation are bound by a polynomial function of time. The core BFT protocol HoneyBadgerBFT uses is ACS, which we have introduced before, so we do not repeat the core idea here. Next, we take a look at how HoneyBadgerBFT adapts to the blockchain scenario.

The theoretical feasibility of ACS has been demonstrated in [14, 21], but the utilization of ACS could cause a censorship problem in blockchains. As described, the ACS used by HoneyBadgerBFT has an RBC phase and an ABA phase. An adversary might find a transaction tx_i (which is delivered during RBC, but the attacker receives it earlier than others) that is disadvantageous to them and attempt to exclude it and whoever proposed it. The adversary can then quickly control f faulty nodes to input 0 to ABA_i for which i is the sender of this transaction, in an attempt to stop it from being agreed upon. Next, the adversary delays RBC_i that corresponds to tx_i , resulting in correct nodes receiving other $2f + 1$ (including those from the adversary) transactions first. As a result, tx_i is censored as the index of its sender will not be included in $SubSet$, and all correct nodes will ignore tx_i .

The authors first improve the efficiency by ensuring nodes propose mostly disjoint sets of transactions. As mentioned before, in HoneyBadgerBFT's ACS, every correct process should propose something due to the n -parallel design and

there is no leader to handle the transactions. Therefore, every process receives all transactions and stores them locally, and randomly chooses a sample such that each transaction is proposed by only one node on average. The authors then propose to use $(f + 1, n)$ -threshold encryption such that the network nodes must work together to decrypt transactions, i.e., only after $f + 1$ (at least one honest) nodes compute and reveal decryption shares for a ciphertext, can the plaintext be recovered. Prior to this, the adversary knows nothing about the encrypted transactions. Finally, the authors argue that selecting a relatively large batch size can improve efficiency, because one ABA instance is needed for every batch proposed by a process, regardless of the size.

4.3.2 BEAT: Adaptations and Improvements on HoneyBadgerBFT.

HoneyBadgerBFT provides a novel atomic broadcast protocol and the basic adaptation of using it in a cryptocurrency-like blockchain. BEAT [50] implements a series of adaptations that adapt to different blockchain scenarios, e.g., append-only ledger (BFT storage) and smart contract (general SMR). Although these two types of blockchains share the same security requirements, their storage requirements are different. The former focuses on decentralised storage, and might use redundancy-reducing mechanisms such as allowing servers to keep only fragments [54, 102, 136, 151], while in contrary, the smart contract form has a more strict requirement on storage as each participant is expected to keep a full redundant copy of all contract states to support contracts executing [117, 149, 160].

To meet the requirements of these two major types of application scenarios, BEAT proposes five protocol instances, BEAT0-BEAT4. BEAT0 utilizes a more secure threshold encryption, and a threshold coin-flipping instead of threshold signature as used in HoneyBadgerBFT, and adopts flexible and efficient erasure-coding support for reliable broadcast. The erasure-coding reduces the bandwidth requirement as the sender only has to send a fragment to any other process instead of the whole batch. BEAT1 replaces the erasure-coded broadcast used in BEAT0 with another erasure-coded broadcast protocol to reduce latency when the batch size is small. BEAT2 opportunistically offloads encryption operations of the threshold encryption to the clients to reduce latency, and achieves causal order [49] that ensures a “first come, first served” manner, which could be useful for financial payments. BEAT0-BEAT2 are designed for general SMR-based blockchains. Besides, BEAT3 and BEAT4 are suitable for BFT storage. Since BFT storage usually only requires each process to store only a fragment, BEAT3 uses a fingerprinted cross-checksum-based [73] bandwidth-efficient asynchronous verifiable information dispersal protocol to broadcast messages, which significantly reduces bandwidth consumption. BEAT4 is optimised for scenarios where clients frequently read only a fraction of the stored transactions, e.g., a portion of a video. It further extends fingerprinted cross-checksum techniques together with a novel erasure-coded asynchronous verifiable information dispersal protocol to reduce access overhead.

4.3.3 Dumbo: Reduction on ABA and Carefully-Used MVBA.

It is found in Dumbo [72] that the n ABA instances terminate slowly when n gets larger and the network is unstable, and the slowest ABA instance determines the running time of HoneyBadgerBFT. Dumbo proposes an improved protocol instance, Dumbo1, which only needs to run κ ABA instances, where κ is a security parameter independent of n . κ is an adjustable parameter; if n is relatively large, the probability that none of $\kappa = \kappa_0$ nodes is honest is at most $(1/3)^{\kappa_0}$ which is safe to neglect, so κ_0 could be selected; otherwise, $\kappa = f + 1$ is used. Committee election is implemented using pseudo-randomness.

The ACS of Dumbo1 is revised from that of HoneyBadgerBFT, as illustrated in Fig. 8. After the n RBC phase, every process executes committee election and κ processes are elected as the committee C , among which at least one process is honest. If an honest process c_j in the committee receives $2f + 1$ values from the RBC phase, it initiates an index-RBC. Each index-RBC is used by c_j to broadcast S_j , the set of $2f + 1$ RBC instance c_j has already received values from. Finally

, κ ABA instances are still needed because there might be two or more honest nodes in the committee, resulting in any two honest nodes $\notin C$ receiving $S_i \neq S_j$, which are both sent from honest committee members (due to asynchrony and different latency). The κ ABA instances are then used to reach agreement on S that contains $2f + 1$ values. For a process $p_i \notin C$, once it receives the indices in S_j from c_j that indicate which $2f + 1$ values in the RBC phase should be agreed upon, it waits until all these values are received. Note that p_i might have received $S_i \neq S_j$; in this case, it will input 1 to only one ABA_i once the $2f + 1$ values in S_i are all received. Then, once p_i has received 1 from any ABA_j , it inputs 0 to all other $\kappa - 1$ ABA instances. As a result, all correct processes will agree on the same $2f + 1$ values and wait for them to be delivered. Because in C at least one process is honest, and this honest process must have received all input values corresponding to the index set S_j . Thus, following the properties of RBC, all other honest nodes will also eventually receive those values.

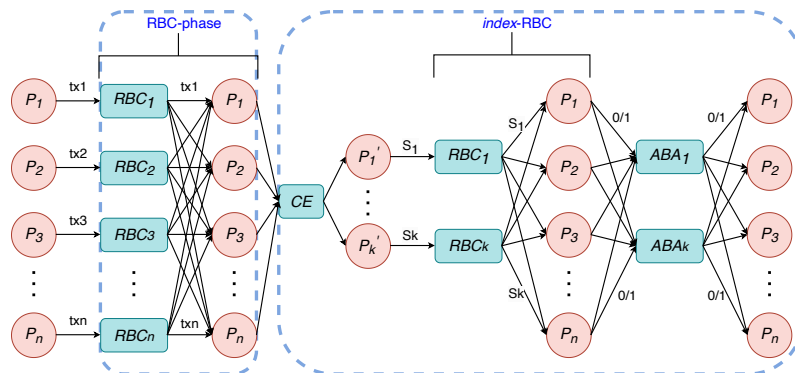

Fig. 8. ACS of Dumbo1

In addition, Dumbo also gives another instance, Dumbo2. As we introduced in 4.1, it has been demonstrated that asynchronous BFT could be built on MVBA, although it is considered complex and impractical in [113]. The authors of Dumbo examine MVBA again and point out that if the message size of the input value becomes small, the situation changes. Therefore, the authors propose Dumbo2 that utilises MVBA in another way: to agree on a set of indices rather than the proposed values themselves. To guarantee that the output of MVBA is valid (the output might be a fake set of indices for which some processes with those indices are faulty and have never broadcast), Dumbo2 uses a variation of RBC called provable RBC, which is realised by combining RBC and threshold signatures. This guarantees that once a message is delivered by provable RBC, it is indeed the case that at least $f + 1$ processes have received this message. Once this set of indices is decided by MVBA, it is guaranteed that at least one honest process has received all values corresponding to these indices. The following idea is similar to that of Dumbo1.

► **Remark.** MVBA and ACS are two techniques for realising asynchronous BFT. Both of these two mechanisms could be reduced to ABA, which is a randomised consensus protocol. Generally, a common coin is used to facilitate the termination of ABA. Threshold cryptography is widely used in all these protocols, including for generating the common coin and building provable RBC. The MVBA protocols were originally used in asynchronous BFT solutions [21, 22, 37] to agree on the proposed values directly, which was found impractical for blockchain scenarios [113]. Then, a number of works [50, 72, 105, 106, 113] utilise ACS, which was initially used for multiparty computation [14], to realise atomic broadcast in blockchain scenarios. In addition, inspired by the notion of ACS, [72] uses MVBA to agree on the indices

of RBC rather than the proposed values themselves to improve performance. The core idea of ACS-based asynchronous BFT is simple: input values to RBC first, and then use ABA to agree on which values should be accepted and wait until these values are eventually delivered by RBC. More optimisation works have been done on ACS and asynchronous BFT [51, 66]; due to content limitation and since our focus is the core ideas of these protocols, we do not introduce them in this paper.

5 TREE AND DAG-BASED BFT

Conventional BFT protocols like PBFT are considered to have scaling problems, as well as recent advanced BFT protocols for blockchain like HotStuff [103, 139]. Researchers have made efforts to improve scalability by applying sharding and partition techniques, as we introduced in Section 3.2. These solutions change the deployment of participants, and achieve scaling at the cost of reduced resilience. A tree is the most intuitive data structure that could improve scaling, and it has been utilised in many cryptocurrency blockchains [89, 90] to address the bottleneck at the leader by organising processes in a tree topology. In addition, the more parallel-looking DAG structure is used in blockchain [152] to organise transactions and ledgers, allowing participants to propose different blocks simultaneously. Since we focus on BFT protocols, we introduce the tree and DAG based solutions in BFT in detail.

5.1 Tree and DAG-based Message Dissemination and Memory Pool Abstraction

Tree and DAG are considered more efficient in nature than a chain due to their parallel structure for organising transactions and blocks [152]. Researchers are also inspired by these structures and have attempted to utilise them to improve efficiency in BFT. Recently, some proposals have optimised data dissemination schemes [119] and memory pool [41] as extensions of existing BFT protocols.

5.1.1 Kauri: Tree-based Message Dissemination and Aggregation.

Kauri [119] is typically designed as an extension of HotStuff [156]. Recall the communication model of HotStuff (see Section 3.4.3), which has four phases. In each phase, the leader performs dissemination and aggregation procedures during each phase, as shown in Fig.5. Kauri assumes that most commonly the number of consecutive faults is small and the network is partially synchronous. It proposes a tree-based dissemination and aggregation scheme to reduce bandwidth consumption on the leader’s side, where the leader is at the tree root. Essentially, Kauri is a speculation-based optimisation mechanism. Because if a process is faulty, all its children could fail to receive the message from the leader. Thus, every process will decide on its own value through a broadcast process anyway, either the value from its parent or a default value \perp (if it receives no value from its parent before a timeout, which is used to guarantee liveness). The tree-based aggregation process is similar: a parent will collect all signatures from its children, form them into an aggregate signature, and send it back to its parent recursively until reaching the tree root. The topology and communication pattern are illustrated in Fig 9. If a correct leader fails to collect enough signatures, Kauri tries to reconfigure the system a certain number of times (determined by a specific mechanism based on an evolving graph; we do not introduce this detail here) to find a correct tree configuration, and will return to the original HotStuff star topology if no correct configuration can be found.

5.1.2 Narwhal: DAG-based Memory Pool.

The authors in [41] pointed out that some consensus protocols in which the leader is expected to broadcast and collect information lead to uneven resource consumption. This phenomenon is also discussed in Kauri, as we introduced above. In addition, it is found in [41] that consensus protocols group a lot of functions into a monolithic protocol, such as

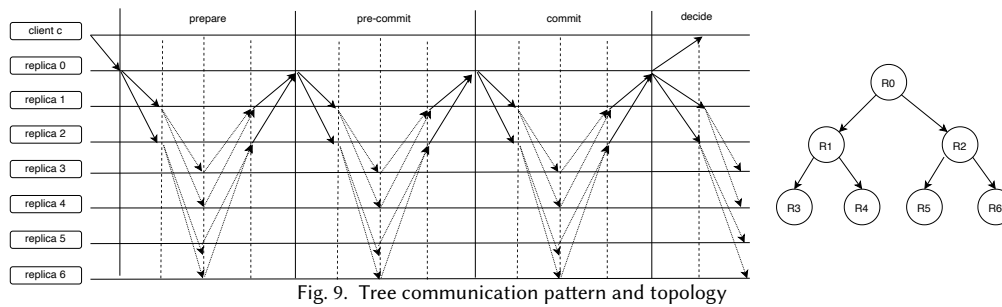

Fig. 9. Tree communication pattern and topology

Bitcoin and LibraBFT [12]. In these protocols, the transactions will be shared among participants and then a subset of them are periodically re-shared and committed as part of the consensus protocol, which causes redundancy. Narwhal is proposed as a better memory pool that separates transaction dissemination (message delivery) from ordering in the consensus protocol. This is theoretically feasible; recall that we pointed out in Section 4.1 that atomic broadcast (could be converted to consensus) could be realised by the reliable broadcast protocol plus the total ordering property. Similarly, Narwhal separates the monolithic consensus protocol into reliable transaction dissemination and sequencing, and the sequencing could be realised by any consensus protocol such as HotStuff or LibraBFT. The consensus protocol used only needs to be performed on a very small amount of metadata instead of the complete transactions/block to increase performance.

We first check how Narwhal realises reliable transaction dissemination. Initially, it assumes clients send transactions to different validators (processes). Ideally, a transaction only needs to be sent to one validator to save bandwidth. Each validator will accumulate the transactions to form a block. Then, validators reliably broadcast [17] each block they create to ensure the integrity and availability of the block. Each block corresponds to a round r (column in the DAG) and contains certificates for at least $2f + 1$ blocks of round $r - 1$. These certificates are used to confirm that the validator has received these blocks and prove they will be available. In addition, the authors propose that every block includes certificates of past blocks, from all validators. By doing this, a certificate refers to a block plus its full causal history (i.e., all blocks directly and indirectly connected to it); therefore, when a block is committed, all blocks in its causal history are committed simultaneously. An example of Narwhal is shown in Fig. 10. Even if the network is unstable and asynchronous, the DAG-based memory pool continues to grow. Because reliable broadcast is used, every validator eventually observes the same DAG and the same certificates. The Narwhal memory pool could be integrated with various BFT protocols. Using HotStuff as an example, in the original HotStuff (see Section 3.4.3 a leader proposes a proposal that is certified by other validators. To be integrated with Narwhal, a leader proposes to commit one (or several) certificates corresponding to the block(s) created by Narwhal. Due to Narwhal's design, once a block is committed, all blocks in its causal history are committed as well. In Fig. 10, once C1 is committed, all blocks in its causal history (blue vertices) are committed, and the same applies to the yellow and green vertices. Hence, a partial order is built: blue vertices (C1) ← yellow vertices (C2) ← green vertices (C3). To build a total order, one can deploy any deterministic algorithm on the partial order, e.g., by sorting by hash.

5.2 DAG-based BFT

Narwhal builds a DAG-based memory pool that abstracts the communication and could be integrated with any other partially synchronous BFT protocols. Nevertheless, asynchronous BFT protocols are also proposed that could be directly

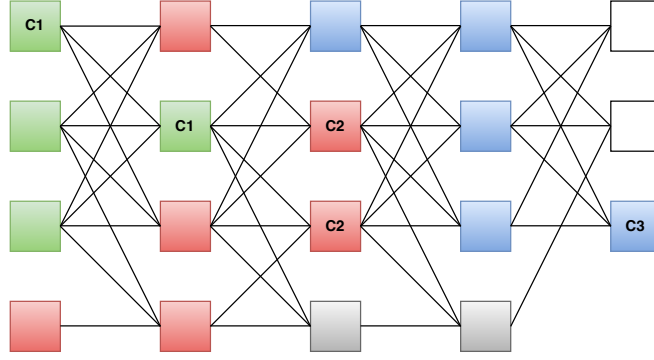

Fig. 10. Example of Narwhal memory pool

deployed on the DAG abstraction. These protocols share a similar core idea: utilize the DAG abstraction with reliable broadcast to build the communication history, then use threshold cryptography to build a common coin to select an anchor block every several rounds (i.e., in each column in the DAG) to establish a partial order, and finally use a deterministic algorithm to build the total order.

5.2.1 DAG-Rider: DAG-based Atomic Broadcast.

Similar to the DAG-based memory pool, DAG-Rider [86] also builds a DAG to abstract communication history. The DAG of DAG-Rider is similar in structure, in which each vertex also refers to $2f + 1$ vertices in the last round (called strong edges in DAG-Rider). The difference is, these $2f + 1$ edges have been included in a vertex when this vertex is broadcasted, rather than being built after an availability certificate is created. In addition, with the goal of implementing an atomic broadcast protocol (see definition 2.11), the validity property should be met. Therefore, for each vertex v in round r , in addition to the $2f + 1$ strong edges referring to the vertices in round $r - 1$, it also refers to at most f vertices in round $r' < r - 1$ such that otherwise there would be no path from v to them. The weak edges are used to guarantee validity, as every message that has been broadcasted must be delivered and needs to be included in the total order.

DAG-Rider assumes that each process broadcasts an infinite number of blocks (vertices). Once a process p_i invokes atomic broadcast for a vertex v , it reliably broadcasts v . The round and source, a.k.a. sender, of the vertex are included in the broadcasted message so that the receiver process knows its location in the DAG. Once p_i receives a vertex, it adds it to its buffer. Then, it continuously goes through its buffer to see if there is any vertex v for which the DAG contains all the vertices that v has a strong or weak edge to. Once this requirement is met, v can be added to the DAG. Once p_i has at least $2f + 1$ vertices in the current round, it advances to the next round by creating and reliably broadcasting a new vertex v' , which is the new atomically broadcasted one (p_i has an infinite number of vertices to be broadcasted).

Once the local DAG is built, each process needs to interpret it. The DAG is divided into waves, each of which consists of four consecutive rounds. This is because after three rounds of all-to-all sending and collecting accumulated sets of values, all correct processes have at least $2f + 1$ common values, by the *common-core* abstraction [24]. Therefore, at least $2f + 1$ vertices $\in V$ in the last round of a wave have a strong path to at least $2f + 1$ vertices $\in U$ in the first round of the same wave. The $2f + 1$ quorum intersection guarantees that if an anchor vertex in (the first round of) wave w is committed by some process p_i , then for every process p_j and for every anchor vertex of a wave $w' > w$, a strong

path exists between these two anchor vertices. In each wave w , an anchor vertex will be selected by a globally known common coin, and it is committed by a process p_i if in p_i 's local DAG there are at least $2f + 1$ vertices in the last round of w . The common-core property guarantees that once an anchor vertex is selected, for any process p_i , it has $\frac{2f+1}{3f+1} \approx \frac{2}{3}$ probability that it has this vertex in its local DAG. It should be noticed that some processes might not have this anchor vertex in their local DAG, so they simply advance to the next wave. However, it should be ensured that all correct processes commit the same anchor vertices. In other words, if some processes committed an anchor vertex, those who do not have it in their local DAG must commit it later. To ensure this, when p_i commits an anchor vertex v in some wave w , and there is a strong path from v to v' such that v' is an uncommitted anchor vertex in a wave $w' < w$, then p_i commits v' in w as well. It is guaranteed by quorum intersection that if any process ever commits v' there must be a strong path, otherwise v' is not committed by anyone. The anchor vertices committed in the same wave are ordered by their round wave numbers, so the anchor vertices of earlier waves are ordered before the later ones. An example of ordering is illustrated in Fig.11. Fig.11 shows the local DAG of p_1 . The highlighted vertices v_2 and v_3 are the anchor vertices of waves 2 and 3, respectively. v_2 is not committed in wave 2 since there are fewer than $2f + 1$ vertices in round 8 with a strong path to v_2 , but it is met in wave 3 since there are $2f + 1$ vertices in round 12 with a strong path to v_2 . Since there is a strong path from v_3 to v_2 (highlighted), p_i commits v_2 before v_3 in wave 3.

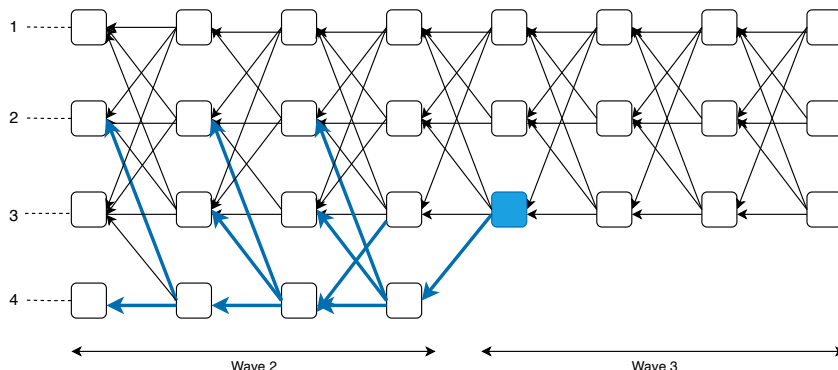

Fig. 11. Illustration of DAG-Rider

It's important to note that although the *common-core* property guarantees the commit probability, it could be attacked by an adversary who can fully control the network. Therefore, the common coin should be unpredictable. This motivation is similar to the unpredictable property in HoneyBadgerBFT and Dumbo. In DAG-Rider, the authors also use threshold signatures, and the elected anchor vertex in a wave w can only be revealed after the processes complete w . Since reliable broadcast is used, every process will eventually observe the same DAG. After the anchor vertices and all vertices in its causal history are committed, the remaining step is to add some deterministic ordering scheme to order the causal history. Finally, every process only needs to atomically deliver the causal history vertices one by one, which is guaranteed to be the same for everyone. It's important to note that atomic broadcast guarantees that every message, if broadcasted, will be delivered. Therefore, if one utilises DAG-Rider for blockchain, an external predicate is needed to check the validity of blocks or transactions.

5.2.2 Task: The Asynchronous Consensus on Narwhal.

We introduced in Section 5.1.2 that the Narwhal DAG memory pool could be integrated with various partially synchronous BFT protocols to propose several anchor blocks as well as their causal history to be committed. However,

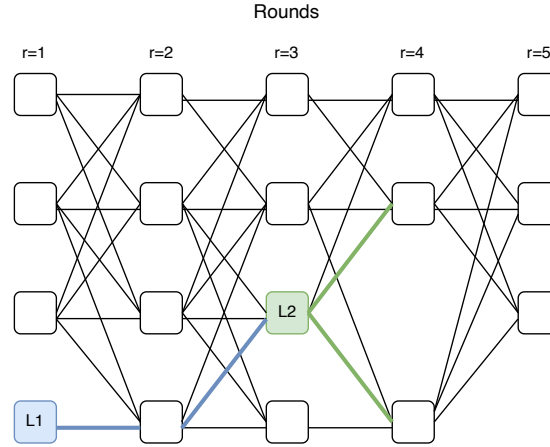

Fig. 12. Illustration of commit rule in Tusk

these partially synchronous BFT protocols make no progress when the network is asynchronous, such as under DDoS attacks. Therefore, the authors propose an asynchronous consensus protocol called Tusk on the DAG. The core idea is similar to that of DAG-Rider: the vertices are broadcasted by reliable broadcast to build the DAG (in Tusk this step has been done by Narwhal), then use threshold signatures to generate a common coin that elects an anchor vertex every several rounds, and processes try to commit the anchor together with all vertices in its causal history to build a partial order, then apply any deterministic scheme to achieve total ordering. However, Tusk is a total ordering protocol on Narwhal rather than an atomic broadcast protocol, which means it does not guarantee that once a vertex is broadcasted, it is ensured to be delivered and ordered. Therefore, in Tusk no weak path exists. If a vertex arrives very late and no certificate of availability is signed, it could be an orphan vertex and thus ignored.

In Tusk, a process (a.k.a. validator in Narwhal) interprets every three rounds of the DAG in Narwhal as a consensus instance. The links in the first two rounds are interpreted as all-to-all message exchange and the third round produces a common coin to elect a unique vertex from the first round to be the leader. To reduce latency, the third round is combined with the first round of the next consensus instance. The goal of this interpretation process is the same as DAG-Rider in that, with a constant probability, it aims to safely commit the anchor of each instance. Once an anchor is committed, its entire causal history (a sub-DAG) in the DAG is also committed and could be totally ordered by any deterministic ordering scheme such as topological sorting [81]. The commit rule is simple: a process commits an anchor vertex v of an instance i if its local DAG includes at least $f + 1$ nodes in the second round of i with links to v . Similar to DAG-Rider, some processes might advance to the next round without observing the elected anchor vertex. To solve this problem and guarantee that every process commits the same anchors, once an anchor vertex v is committed, Tusk also continuously checks if there are any previous anchor vertices in v 's causal history, and commits previous anchor vertices if they exist. The commit rule is illustrated in Fig 12. The commit rule requires $f + 1$, which is different from DAG-Rider; the probability of each anchor meeting the commit rule is $\frac{1}{3}$.

► **Remark.** All DAG-based BFT protocols are based on a similar idea: to divide consensus or atomic broadcast into two separate protocols: a reliable broadcast protocol and a total ordering protocol. This scheme separates message dissemination from ordering to improve performance and fit better in asynchronous networks. With this approach,

Table 1. Comparison of core protocols under different timing assumption.

Protocol	Timing	Termination	Resilience	Components
Byzantine agreement (Sign)[100]	Synchronous	Deterministic	$N > 2f$	Message, signature
Byzantine agreement (Oral)[100]	Synchronous	Deterministic	$N > 3f$	Message
Ben-Or’s binary consensus[13]	Asynchronous	Eventually	$N > 2f/N > 5f$	Message, random coin
Bracha’s RBC[17]	Asynchronous	Eventually	$N > 3f$	Broadcast message
Vector consensus[37]	Asynchronous	Eventually	$N > 3f$	RBC, ABA, MVBA
ACS[14]	Asynchronous	Eventually	$N > 3f$	RBC, multiple ABA
PBFT[26]	Partial synchronous	Deterministic	$N > 3f$	Message, signature

Table 2. Synchronous protocols

Protocol	Resilience	Components	Functions	Additional Requirements
Byzantine agreement (Sign)[100]	$N > 2f$	Message, signature	Guarantees same value for honest participants	None
Byzantine agreement (Oral)[100]	$N > 3f$	Message	Guarantees same value for honest participants	None
SAFEbus/TTP[76, 92]	$N > 3f$	Message	Builds interactive consistency using Byzantine agreement	Clock synchronisation
ScalableBA[88]	$N > 3f$ with prob. 1	Message, secret sharing	Significantly reduces communication complexity	Private channels

each process only needs to check its local DAG to make progress and no further communication is needed. Recently, a DAG-based asynchronous BFT protocol with optimisation for synchronous networks has been proposed [137], which maintains the same core ideas as other asynchronous DAG-BFT protocols but adds timeouts to boost performance in synchronous networks. The DAG-based abstraction of building a DAG to represent communication and interpreting it locally has been considered before [30, 45], but was not realized in the Byzantine setting. Tree [131] and DAG-based [9, 33, 135, 152] communication abstractions and system structures are also widely used in DLT, which is an extended notion of blockchain where the structure is no longer required to be a “chain”.

6 SUMMARIES AND COMPARISONS OF DIFFERENT BFT PROTOCOLS

The comparison of core protocols of synchronous, asynchronous and partially synchronous systems is shown in Table 1.

Originating from Lamport’s Byzantine generals problem, the distributed fault tolerance research could be classified into three main categories: synchronous, asynchronous and partially synchronous, according to timing assumptions. Synchronous algorithms were the earliest researched. However, due to the requirement of synchrony, synchronous algorithms are generally deployed with clock synchronisation mechanisms. For example, in aviation control systems, a time-triggered bus might be used [129], for which clock synchronisation is a fundamental requirement. Based on the synchronous bus, applications that perform safety-critical functions must generally be replicated for fault tolerance. For example, several computers need to perform the same computation on same data, and any disagreement could be viewed as a fault; then comparisons can be used to detect faults. A vital requirement for this approach is that the replicated computers must work on the same data. Therefore, the data distribution needs to be identical for every computer. Byzantine agreement (or Byzantine broadcast) can then be used to achieve this requirement. In addition, due to synchrony, the consensus problem which requires consistency and total order could be solved by executing Byzantine agreement one by one, because everyone knows the order. The improvements and use cases of synchronous Byzantine agreement protocols are shown in Table 2.

However, due to the strong requirement of synchrony, synchronous Byzantine protocols have limited utilisation ; they are typically implemented with physically proximate participants, such as in SAFEbus [76] and TTP [92]. However,

when the timing assumption changes from synchronous to partially synchronous, the consensus problems could be transformed into an agreement problem that ensures every honest participant has the same value of request plus an ordering problem that ensures every honest participant executes the requests in the same order. In the representative partially synchronous consensus protocol PBFT, each follower needs $2f$ *prepare* messages that match the *pre-prepare* message before *committing*. In the worst case, a follower might receive f *prepare* messages from Byzantine nodes first, and in this scenario, it needs to gather all $3f$ *prepare* messages. This also shows why PBFT needs partial synchrony for liveness: if the last f messages are delayed for a long time before GST, during this period, the follower will be unable to distinguish whether the mismatch is caused by the leader sending equivocal messages or f Byzantine nodes sending fake messages. Then, after GST, followers will detect if the mismatch is caused by the leader and propose a *view change*. The agreement protocol is integrated within the PBFT consensus: the $2f$ *prepare* messages plus 1 *pre-prepare* message guarantee that no honest participant will choose a different value after the *prepare* phase. After the agreement protocol, the *commit* phase ensures that the order of requests is identical for all honest followers. The quorum size in PBFT is $2f + 1$ out of $3f + 1$ overall nodes; this is because the leader might be Byzantine, and $2f + 1$ ensures that at least $f + 1$ messages are from honest participants, hence at least 1 honest follower exists in any quorum. Because the honest follower does not collude with the Byzantine leader, the leader will never be able to separate the system and convince different quorums to commit two different values (Lemma. 3.2). However, if the leader cannot send equivocal messages to followers, the quorum size could possibly be reduced in certain scenarios. If we can guarantee that all participants cannot send equivocal messages to others, e.g., by using TEE [32], the quorum size could be reduced to $f + 1$ among $2f + 1$ nodes. BFT consensus protocols in the partially synchronous model are listed in Table. 3.

Table 3. Partial synchronous protocols

Protocol	Resilience	Components	Functions	Additional Requirements
PBFT[26]	$N > 3f$	Message, signature	Guarantees unique order for SMR	GST for liveness
Zyzyva[93]	$N > 3f$	Message, signature, crypto proof	Guarantees unique order for SMR	Speculation
QU[1]	$N > 5f$	Client, quorum, crypto validation	Achieves similar SMR functionality using quorums	Shifts tasks to client
HQ[40]	$N > 3f$	Client, quorum, certificates	Improves contention and resilience of Q/U	Certificates for solving contention
RBFT[7]	$N > 3f$	$f+1$ BFT instances	Makes BFT scalable	$N > 3f$ in each instance
CBASE[94]	$N > 3f$	BFT with relaxed order	Allows concurrent execution of independent requests	A paralleliser for contention safety
Eve[83]	$N > 3f$	Parallel requests with speculation	Speculatively executes requests concurrently	Re-executes when executions diverge
EZBFT[6]	$N > 3f$	Enhanced replicas and multiple BFT	Multiple instances to boost throughput	Clients need to resolve contention
ME-BFT[151]	$N > 3f$	BFT, full and light replicas	Reduces all-to-all communication to scale by structure	$N > 3f$ in full replicas, CRDT
SBFT[71]	$N > 3f$	BFT, threshold/aggregated signature	Reduces all-to-all communication to scale by signature	Collector to collect signatures
Mir-BFT	$N > 3f$	BFT with parallel partition	Multiple leaders to achieve scalability	Partitions the request hash space
CNV[36]	$N > 2f$	BFT, TMO	Uses TMO to restrict Byzantine failures	TTCB for basic security service
A2M[32]	$N > 2f$	BFT, attested append only memory	Uses append only memory to avoid equivocation	Realises the append only memory
MinBFT[142]	$N > 2f$	BFT, USIG	USIG assigns the sequence	Public key crypto for USIG
CheapBFT[82]	$N > 2f$	MinBFT, CASH	CASH manages counters and can authenticate messages	Falls back to MinBFT after failure
Tendermint[19]	$N > 3f$	PBFT, power-based quorum intersection	Replaces $2f+1$ messages with $2f+1$ voting power	None
Algorand[68]	$N > 3f$	Byzantine agreement, VRF, binary consensus	Byzantine agreement for synchrony, binary consensus for asynchrony	Common coin for binary consensus
HotStuff[156]	$N > 3f$	Threshold signature, quorum certificate	Replaces message quorums with quorum certificates	Sufficient computational power
Kauri[119]	$N > 3f$	Tree-based dissemination and aggregation	Extension of HotStuff, replaces the communication model	Tree topology

In the asynchronous settings, due to the restrictions of the FLP impossibility, which states that no “deterministic” consensus protocol exists, consensus protocols relax the termination requirement i.e., the protocol eventually terminates with probability 1. In all the asynchronous consensus protocols we introduced, RBC is used to guarantee that any sender cannot send equivocal messages (otherwise the protocols might be too complex). Therefore, beyond the RBC protocol, every node is not a traditional Byzantine node; its malicious behaviour is restrained, and it can only either broadcast same messages or not broadcast at all. Three research paths are being conducted: the first one is to utilise ABA to construct MVBA, then implement vector consensus from MVBA. Once the vector is confirmed, atomic broadcast (equivalent to BFT-SMR) could be built by delivering values in the vector in a deterministic order. Another path is similar; it implements ACS using ABA, then implements atomic broadcast. The difference is that ACS is more suitable for batching, i.e., n participants exchange messages simultaneously. The third pathway does not utilise ABA for randomisation to evade the FLP impossibility result. Instead, it first broadcasts messages by RBC to ensure that everyone will eventually receive the same messages, then uses a DAG to build the message history and applies randomness by utilising a VRF to select anchor vertices with a probability. Finally, a deterministic order could be built on the anchor vertices to form atomic broadcast. The quorum size in asynchronous consensus is $2f + 1$ among $3f + 1$ nodes. However, in contrast to partially synchronous consensus where GST exists, in asynchronous consensus a node might never have the chance to receive $3f + 1$ messages, and thus cannot rely on it for liveness. Therefore, once a node observes $2f + 1$ messages (or that instances have terminated), it must move on to the next step as it can never determine whether the remaining f messages will be delivered or not, because in an asynchronous network, one can never distinguish if a message is delayed or lost. BFT consensus protocols in the partially asynchronous assumptions are summarised in Table. 3.

Table 4. Asynchronous protocols

Protocol	Resilience	Components	Functions	Additional Requirements
Ben-Or’s[13]	$N > 2f/N > 5f$	Message, random coin	Terminates with probability 1	Binary value
Bracha’s RBC[17]	$N > 3f$	Broadcast message	Ensures that the sender cannot equivocate	None
Vector consensus[37]	$N > 3f$	RBC, ABA, MVBA	RBC to restrain Byzantine failure, ABA for asynchrony, MVBA for agreement, deterministic order for atomic broadcast	Common coin for binary consensus
ACS[14]	$N > 3f$	RBC, multiple ABA	RBC to restrain Byzantine failure, multiple ABA for agreement, deterministic order for atomic broadcast	Suitable for batch settings
HoneyBadgerBFT[113]	$N > 3f$	ACS, threshold encryption	ACS for agreement, threshold encryption to resist censorship	Suitable for blockchains
BEAT[50]	$N > 3f$	Asynchronous atomic broadcast	Implements asynchronous broadcast for different scenarios	Fingerprinted cross-checksum
Dumbo[72]	$N > 3f$	Provable-RBC, ABA, MVBA, revised ACS, threshold signature	Crypto election to reduce ABA instances; uses MVBA to agree on indices rather than on the requests	Suitable for blockchains/batch settings
DAG-Rider[86]	$N > 3f$	RBC, DAG, threshold signature, common coin	DAG for communication abstraction, common-core for committing anchor blocks and their causal history, deterministic order for atomic broadcast	Each process broadcasts an infinite number of blocks
Tusk[41]	$N > 3f$	RBC, DAG, VRF, common coin	An ordering protocol for the DAG mempool	Unlimited memory

7 FUTURE BFT RESEARCH ISSUES

The BFT problem has been a long-standing research field since Lamport [96] proposed it in the 1970s. A series of notions and solutions have been proposed since then, including SMR, reliable broadcast, and randomised consensus, which have built the cornerstone for distributed services. BFT has radiated energy again with the advance of blockchain,

which, although it has more strict requirements, is essentially an SMR problem and could be built on BFT-SMR with optimisations and justifications. It also turns out that with the fast development of the Internet of Everything [91], networks are becoming more collaborative to support high-level applications, which generates demand for consensus protocols to provide a consistent and trustworthy cooperative platform. In this section, we introduce future research topics in BFT, including optimisations of the protocols themselves, adaptation to deployment on various applications, and improvements for future communication environments.

7.1 Fundamental Research and Optimisations on the BFT Primitives

7.1.1 Fault Tolerance without Total Order.

Recently proposed BFT solutions [50, 72, 113, 156] are total ordering protocols for SMR. Although SMR is the gold standard for implementing ideal functionality, it incurs higher overhead as in some cases, the cost of totally ordering all transactions and requests is unnecessary. It was found by Lamport [99] that sometimes only a weaker problem than total ordering consensus needs to be solved. This finding has led to fundamental research like EPaxos [114]. In addition, this finding also appears in cryptocurrency blockchain settings [101]. Further, it is also considered in general blockchain settings [84, 151] that Conflict-free Replicated Data Types [133] have weaker requirements on ordering. Releasing the total ordering requirements could decrease system overhead. Thus, protocols based on weak ordering requirements, as well as methods to achieve weak ordering in current total ordering protocols deserve further research efforts.

7.1.2 Scalability and Performance.

Scalability of BFT is bounded by complexity, including communication complexity and running time complexity. Sharding technology and cryptography are used to reduce communication complexity (e.g., [5] and [156], respectively), but sharding will alter the deployment structure and reduce the fault tolerance ability, while cryptography requires more powerful computation. The balance between computation and complexity should be researched.

In the early work on asynchronous MVBA, the protocols had a communication complexity of $O(n^2)$ for agreement on each message ($O(n^3)$ if there are n peers). Recently, asynchronous BFT protocols utilize ACS to reach asynchronous agreement on a common core. HoneyBadgerBFT uses n -parallel ACS to reduce the communication complexity to $O(n^2)$ ($O(n)$ for each message). Dumbo reduces the number of ABA instances to optimise the time complexity and proposes to carefully use MVBA to further reduce time complexity. However, an open question remains: due to the n -parallel ABA instances, the time complexity of ACS is $O(\log n)$ [72] (in Dumbo-ACS, it is reduced to $O(\log \kappa)$, κ is a constant). However, we expect that the time complexity could be reduced to $O(1)$ in future work.

7.1.3 Configuration and Reconfiguration.

In nearly all of the recently proposed works [41, 50, 66, 72, 86, 113, 137, 156] that utilise cryptography, it is assumed that a reliable third party exists to initially distribute keys and configure the Public Key Infrastructure (PKI). However, this open problem needs to be solved in real implementations, as in some blockchain scenarios there are no trusted third parties to initialise the platform. In addition, the participants might change during the system's progress even after initial configuration. Therefore, future research should consider methods for initial configuration without trusted third parties and reconfiguration mechanisms during the system's progress, both of which should not significantly impact system performance.

7.2 Deployment in Different Types of Blockchain applications

It is known that most of the permissioned blockchains are based on BFT-SMR [144]. This is because although BFT-SMR protocols provide a higher throughput, they generally less scalable, which generally only support up to several hundred of nodes. It is less decentralised due to the utilisation of PKI which is a centralised service to some degree. Nevertheless, there are still efforts to implement BFT in permissionless blockchains. These works integrate BFT with Proof-of-Stake (PoS) and PoW to resist Sybil attack [47]. To launch Sybil attack, an attacker creates multiple identities in the blockchain to cause security issues. Sybil-resistance is unique in permissionless blockchains, and PoS, PoW are two widely used techniques to realise it. By integrating PoS/PoW together with BFT, a blockchain can enjoy both Sybil-resistance and high throughput. However, in permissionless blockchains, one can join or leave the system freely, which again leads to the configuration and reconfiguration research issue. Except for the permissioned/permissionless classification, blockchain can also be divided into different types according to different domains according to their use cases, such as financial, medical, governmental blockchains, etc. Different types of blockchain have different property requirements. For example, in financial applications such as cryptocurrencies [116], safety, decentralisation and fairness are strong demands but throughput could be balanced. In governmental [85] and medical blockchains [111, 150], they usually take throughput and safety into account while decentralisation is a supplement, while in Internet of Things (IoT) [8, 58, 78] applications, an increasing number of heterogeneous devices are connected and their ability of communication is better than that of complex cryptography algorithms, which makes rethink of the schemes such as HotStuff that applies cryptography but reduces communication. In addition, IoT systems might be sensitive to latency, raising higher requirements on reducing time complexity. Different requirements lead to a common belief that no one-size-fits-all BFT protocol exists. Research efforts are necessary on optimisations and adaptations on current protocols and even novel protocols that could satisfy different requirements.

7.3 Deployment in Complex Application Structures

The original protocols of BFT assume a flat system structure in which every participant has completely the same status. This includes the protocol design and the underlying peer-to-peer communication. This assumption holds for distributed service models and cryptocurrencies. However, in some other real applications, such as Internet of Things and Industrial Internet of Things [58, 78], healthcare [150], and autonomous driving [25, 57], the participants, for example, vehicles and Road Side Units (RSU), have different resources including computation power, bandwidth and may have different levels, i.e., leader-member relations that make the structure hierarchical. Reputation [158] and sharding [95] techniques have been used in partial BFT protocols to mitigate these issues, but there is still a lack of adaptations for asynchronous and DAG-based consensus in these contexts. In addition, research efforts are needed on how to carefully deploy consensus protocols that adapt to the system structure and yield better performance .

7.4 BFT in Next Generation Communications

With the rapid development of communication technology and the gradual maturity of 5G technology, researchers have various prospects for the development direction of the next generation communications. Among them, wireless distributed consensus based on the idea of distributed consensus algorithms has been proposed in some research [159]. Most of this idea is aimed at the design of communication system architectures for the Internet of Things (IoT) systems. Most current IoT systems adopt a centralised architecture, which requires a central controller to exchange data with other nodes. However, the increasing number of IoT nodes brings more challenges to the reliability and stability of the

central node. In addition to the centralised architecture, implementing a distributed consensus network in wireless communication systems may be an alternative or supplementary solution [161]. In a wireless distributed consensus system, the transmission and interaction of information no longer completely depends on the scheduling of the central node but instead realises reliable execution request transmission according to the consensus algorithm. Since the design of BFT algorithms leave a fault-tolerant space for Byzantine nodes, node failures and link failures in the wireless communication system can be recovered within a certain limit [154]. Nevertheless, adapting and refining the original consensus algorithms to suit the specific requirements of a given communication system is paramount.

8 USE CASES OF BLOCKCHAINS

Blockchains, sometimes being called DLT, originated from Bitcoin [116] and have been explored and used in different domains. As the most popular killer application in blockchain, Bitcoin has driven the trend of research on cryptocurrency. With the development of cryptocurrency, in 2013, Ethereum [149] was proposed, which provides a platform that supports any extendable application based on consensus and cryptocurrency. At this stage, researchers also abstracted blockchain from cryptocurrency as a decentralised, trustless platform or component that could be integrated with various information systems, including financial, healthcare, cloud computing, Internet of Things, supply chain, etc. With the power of blockchain, the trust, security, and privacy aspects of these information systems could be improved. In addition, the decentralised idea has gradually become a novel paradigm for brand new design models based on decentralisation and the crypto ecosystem. Building on the underlying blockchain infrastructure, Web3, the next generation of the internet, is emerging.

In the preceding sections, we systematically reviewed the BFT technology which originated nearly 40 years ago before blockchain and is still heavily researched to empower blockchain systems. In this section, we shift our view to post-blockchain use cases, including blockchain integrated with Web2 and general scenarios, and Web3 visions which use blockchain as the underlying protocol layer. Our goal in this section is not to provide a comprehensive review of as many blockchain systems as possible, nor to advocate any form of blockchain. Instead, we aim to present use cases and demonstrate how blockchain could be used in the real world and how blockchain may evolve in the future. The exploration of real-world applications and futuristic visions serves to illuminate the vital importance of sustained research on enduring BFT problems. By offering a panoramic overview of the distributed and decentralised system models before and after blockchain, we aspire to stimulate increased research that spans beneath (supporting blockchain) and atop (constructing upon blockchain) the blockchain paradigm.

8.1 Web2 Applications and General Scenarios

8.1.1 Financial Applications. The financial application Bitcoin and its variants are exactly how blockchains became famous as they offer a decentralised, trustless platform and environment for people to exchange value. Financial applications are still a major focus in blockchain research. Financial use cases include asset management, insurance, and payment. For example, RippleNet [128] is exploring financial trading and management on blockchain as well as new business models. Another example in the insurance industry is OpenIDL [123], which is built on the IBM Hyperledger Fabric blockchain platform [79]. OpenIDL was initiated in 2020 by the American Association of Insurance Services (AAIS) and aims to solve data sharing, privacy, standardisation, and auditability challenges in the insurance industry. These two use cases show that financial applications can be built on both cryptocurrency and general blockchain platforms.

8.1.2 Healthcare and Medical Services. With the need for building secure and reliable data storage systems, research has been conducted to explore blockchain applications in healthcare and medicine. The intuitive idea is to use blockchain as a tamper-resistant platform to store data so that all historical data and operations are immutable, thus improving trust and safety. Numerous efforts have been made in this domain to build health records, medical data sharing and analysis platforms, medical supply chain records, etc [3]. In addition, recent research has also considered the future Internet of Medical Things (IoMT) [127]. Moreover, blockchain in healthcare and medicine has also attracted government agencies. For example, the Centre for Surveillance Epidemiology and Laboratory Services of the Centres for Disease Control (CDC) built a proof of concept to track the opioid crisis. The U.S. Department of Health and Human Services (HHS) is also discussing the potential of blockchain in public and private healthcare[62].

8.1.3 Supply Chain Management. The blockchain naturally provides a tamper-proof, immutable, and transparent history, which is a perfect match for supply chains. The U.S. Food and Drug Administration (FDA) launched pilot programs to utilize blockchain as a solution to assist drug supply chain stakeholders with developing electronic, interoperable capabilities that will identify and trace certain prescription drugs as they are distributed within the United States [126, 141]. Blockchain-empowered supply chains are also being researched in industry. For example, a fish provenance and quality tracking framework was proposed in [145]. The World Wildlife Fund (WWF) also launched a supply chain project, OpenSC, which is a global digital platform based on blockchain that tracks the journey of food along the supply chain.

8.1.4 Cloud Computing. Fusing blockchain with cloud computing has the potential to enhance security and privacy aspects. Blockchain has been utilised in enhancing traditional cloud access control. The major drawback of traditional cloud access control schemes is that they highly rely on centralised settings. Blockchain-based access control [120, 140] has a few benefits, including traceability and immutable governance provided by the blockchain structure, and the involvement of all stake holders by the requirement of consensus. Blockchain is also considered in cloud resource allocation due to its economical nature; the tokenised incentive-based resource allocation could increase the resource sharing rate and reduce the energy cost [64]. Some approaches have embedded blockchain to provide a secure and reliable environment for data sharing and collection in deep learning algorithms [107].

8.1.5 Edge Computing and Internet of Things. As an extension of cloud computing, edge computing [152, 155] aims to offload heavy centralised tasks from the cloud to decentralised edge servers. With the development of 5G, the Internet of Things, and the Internet of Vehicles (IoV), edge computing has gradually played an important role in these system models as the infrastructure to provide low latency computation and data processing, making it a key technology for realising various visions for the next-generation Internet. Having the same distributed architecture, edge computing is a perfect use case for blockchain applications. In addition to access control and resource allocation, which have already been considered in cloud computing, blockchain-assisted decentralised data storage for IoT devices [152], secure multi-party computation (MPC)[70], and self-sovereign identity (SSI)[11] are also being researched.

► **Remark.** Some of the financial applications that require a completely decentralised permissionless network use cryptocurrency consensus protocols such as PoW and PoS, while most of the general applications in a more controllable network consider using permissioned blockchains, which tend to deploy BFT consensus for much higher efficiency. Current BFT consensus protocols still have a long way to go to satisfy the increasing demands on throughput, security, and latency requirements in various blockchain applications.

8.2 Web3 Visions

8.2.1 Layer1 and Layer2 Blockchain. Layer1 and Layer2 blockchains are the fundamental layers for the web3 ecosystem. Layer1 blockchains, a.k.a. smart contract platforms, are the settlement layer that provides decentralisation, security, and decentralised programmability for the network through consensus, scripts, smart contracts, virtual machines, and other protocols. For instance, Bitcoin [116] and Ethereum [149] are layer1 blockchains. Layer2 blockchains are based on layer1, which could be regarded as off-chain protocols [42]. Generally, Layer2 utilizes technologies including side chains and state channels to improve throughput without altering the basic layer1 blockchain rules. For example, Lightning Network [125] is a layer2 implementation on Bitcoin, and Polygon [63] is a layer2 solution on Ethereum. In addition to layer2 on permissionless blockchains, layer2 could also be built on permissioned blockchains [65]. The different layers of the web3 ecosystem are illustrated in Fig. 13.

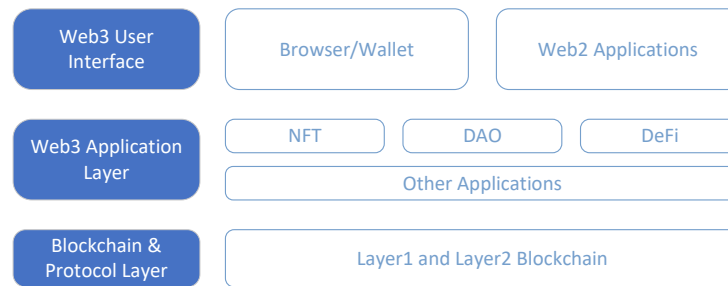

Fig. 13. Illustration of Web3 Ecosystem

8.2.2 NFT. Non-fungible tokens (NFTs) are digital assets built on blockchain technology. Unlike cryptocurrencies such as Bitcoin, NFTs represent not only monetary value but also unique digital assets, meaning that each NFT is distinct from all others [143]. The uniqueness and ownership confirmation functions realised by blockchain technology have enabled NFTs to be widely used in Web3. For example, since NFTs can be used to prove the ownership of digital content, artists can convert their works into NFTs, ensuring their uniqueness and authenticity. Users can obtain ownership of content by purchasing NFTs, and creators can break the shackles of traditional monopoly platforms and directly benefit from their works [115]. Another example is that NFTs can endow items, land, characters, and buildings in virtual reality environments with true value [115]. The virtual assets connected by NFTs can even be circulated across platforms, providing users with more practical autonomy.

8.2.3 DAO. Decentralised autonomous organisations (DAOs) have their origins rooted in Ethereum. They are internet-native communities/organisations that are executed through smart contracts and recorded by blockchain, and featured as open and transparent [130]. In contrast to traditional Internet organisations, being supported and influenced by blockchain technology, DAOs emphasise a flat personnel structure and a decentralised decision-making mechanism. They decentralise decision-making rights to all members as much as possible, write execution logic into smart contracts, and record all the critical activities on the chain [55]. The decentralisation of infrastructure and the decentralisation of management spirit in DAOs are complementary to each other. Blockchain technology provides a reliable infrastructure for decentralised autonomous organisations, enabling them to operate autonomously and make decisions without trusted intermediaries.

8.2.4 DeFi. Decentralised Finance (DeFi) is a newly emerged financial system built on blockchain technology. In contrast to traditional financial services, DeFi services are usually built on decentralised smart contract platforms for executing financial agreements and transactions, providing financial services that do not rely on traditional financial institutions and intermediaries. There are various financial products in the DeFi ecosystem, such as lending agreements, liquidity pools, decentralised exchanges, stablecoins, etc. [148]. These products can be realised through smart contracts, enabling users to participate in a more open and diversified financial market. The openness and programmability brought by blockchain to DeFi enables anyone to build and deploy their own financial applications, promoting innovation and competition [31]. This provides users with more choices and drives the evolution of financial services.

► **Remark.** Web2 and Web3 applications can be built upon both permissioned and permissionless blockchains. Web3 is considered to potentially change the current Internet service model, and Web3 applications usually assume an ideal underlying blockchain protocol layer and focus on the application layer. However, current blockchain consensus protocols still encounter challenges, and ongoing research into consensus protocols, including Byzantine Fault Tolerance (BFT) and hybrid approaches (e.g., BFT-based PoW), continues to be a focal point of interest.

9 CONCLUSION

This article provides a comprehensive review of BFT protocols for the long-term popular Byzantine fault-tolerance problems, from the original ones to state-of-the-art protocols that were designed for general applications before blockchain, such as distributed databases. In addition, we also review post-blockchain BFT protocols that are specifically designed for blockchain and cryptocurrency scenarios. We introduce important concepts, properties, and technologies in Byzantine fault-tolerance protocols, and elaborate on how BFT protocols achieve these properties by employing specific designs and technologies in general applications and blockchain. After reviewing the development of BFT before blockchain and discussing the research issues in BFT that span beneath blockchain, we finally summarise the real-world Web2 and general use case scenarios and the rapidly developing Web3 visions that are constructed upon blockchain to show the power of blockchain and demonstrate the necessity of BFT research in the future.

REFERENCES

- [1] Michael Abd-El-Malek, Gregory R Ganger, Garth R Goodson, Michael K Reiter, and Jay J Wylie. 2005. Fault-scalable Byzantine fault-tolerant services. *ACM SIGOPS Operating Systems Review* 39, 5 (2005), 59–74.
- [2] Michael Abd-El-Malek, Gregory R Ganger, Garth R Goodson, Michael K Reiter, and Jay J Wylie. 2005. Lazy verification in fault-tolerant distributed storage systems. In *24th IEEE Symposium on Reliable Distributed Systems (SRDS'05)*. IEEE, 179–190.
- [3] Cornelius C Agbo, Qusay H Mahmoud, and J Mikael Eklund. 2019. Blockchain technology in healthcare: a systematic review. In *Healthcare*, Vol. 7. MDPI, 56.
- [4] Marcos Kawazoe Aguilera and Sam Toueg. 1998. *Correctness proof of ben-or's randomized consensus algorithm*. Technical Report. Cornell University.
- [5] Y. Amir, C. Danilov, J. Kirsch, J. Lane, D. Dolev, C. Nita-Rotaru, J. Olsen, and D. Zage. 2006. Scaling Byzantine Fault-Tolerant Replication to Wide Area Networks. In *International Conference on Dependable Systems and Networks (DSN'06)*. 105–114. <https://doi.org/10.1109/DSN.2006.63>
- [6] Balaji Arun, Sebastiano Peluso, and Binoy Ravindran. 2019. ezBFT: Decentralizing Byzantine Fault-Tolerant State Machine Replication. In *2019 IEEE 39th International Conference on Distributed Computing Systems (ICDCS)*. 565–577. <https://doi.org/10.1109/ICDCS.2019.00063>
- [7] Pierre-Louis Aublin, Sonia Ben Mokhtar, and Vivien Quéma. 2013. RBFT: Redundant Byzantine Fault Tolerance. In *2013 IEEE 33rd International Conference on Distributed Computing Systems*. 297–306. <https://doi.org/10.1109/ICDCS.2013.53>
- [8] Abdullah Ayub Khan, Asif Ali Laghari, Zaffar Ahmed Shaikh, Zdzislawa Dacko-Pikiewicz, and Sebastian Kot. 2022. Internet of Things (IoT) Security With Blockchain Technology: A State-of-the-Art Review. *IEEE Access* 10 (2022), 122679–122695. <https://doi.org/10.1109/ACCESS.2022.3223370>
- [9] Leemon Baird. 2016. Hashgraph consensus: fair, fast, byzantine fault tolerance. *Swirls Tech Report, Tech. Rep.* (2016).
- [10] Shehar Bano, Alberto Sonnino, Mustafa Al-Bassam, Sarah Azouvi, Patrick McCorry, Sarah Meiklejohn, and George Danezis. 2019. SoK: Consensus in the age of blockchains. In *Proceedings of the 1st ACM Conference on Advances in Financial Technologies*. 183–198.
- [11] A Jameer Basha, N Rajkumar, Mohammed A AlZain, Mehedi Masud, and Mohamed Abouhawwash. 2022. Fog-based Self-Sovereign Identity with RSA in Securing IoMT Data. *Intelligent Automation & Soft Computing* 34, 3 (2022).

- [12] Mathieu Baudet, Avery Ching, Andrey Chursin, George Danezis, François Garillot, Zekun Li, Dahlia Malkhi, Oded Naor, Dmitri Perelman, and Alberto Sonnino. 2019. State machine replication in the libra blockchain. *The Libra Assn., Tech. Rep* 1, 1 (2019).
- [13] Michael Ben-Or. 1983. Another advantage of free choice (extended abstract) completely asynchronous agreement protocols. In *Proceedings of the second annual ACM symposium on Principles of distributed computing*. 27–30.
- [14] Michael Ben-Or, Boaz Kelmer, and Tal Rabin. 1994. Asynchronous secure computations with optimal resilience. In *Proceedings of the thirteenth annual ACM symposium on Principles of distributed computing*. 183–192.
- [15] Alysso Bessani, João Sousa, and Eduardo EP Alchieri. 2014. State machine replication for the masses with BFT-SMART. In *2014 44th Annual IEEE/IFIP International Conference on Dependable Systems and Networks*. IEEE, 355–362.
- [16] Carlos Eduardo Bezerra, Fernando Pedone, and Robbert Van Renesse. 2014. Scalable State-Machine Replication. In *2014 44th Annual IEEE/IFIP International Conference on Dependable Systems and Networks*. 331–342. <https://doi.org/10.1109/DSN.2014.41>
- [17] Gabriel Bracha. 1987. Asynchronous Byzantine agreement protocols. *Information and Computation* 75, 2 (1987), 130–143.
- [18] Gabriel Bracha and Sam Toueg. 1983. Resilient Consensus Protocols. In *Proceedings of the Second Annual ACM Symposium on Principles of Distributed Computing (Montreal, Quebec, Canada) (PODC '83)*. Association for Computing Machinery, New York, NY, USA, 12–26. <https://doi.org/10.1145/800221.806706>
- [19] Ethan Buchman, Jae Kwon, and Zarko Milosevic. 2018. The latest gossip on BFT consensus. *arXiv preprint arXiv:1807.04938* (2018).
- [20] Christian Cachin, Rachid Guerraoui, and Luis Rodrigues. 2011. *Introduction to reliable and secure distributed programming*. Springer Science & Business Media.
- [21] Christian Cachin, Klaus Kursawe, Frank Petzold, and Victor Shoup. 2001. Secure and Efficient Asynchronous Broadcast Protocols. In *Advances in Cryptology – CRYPTO 2001*, Joe Kilian (Ed.). Springer Berlin Heidelberg, Berlin, Heidelberg, 524–541.
- [22] C. Cachin and J.A. Poritz. 2002. Secure INtrusion-Tolerant Replication on the Internet. In *Proceedings International Conference on Dependable Systems and Networks*. 167–176. <https://doi.org/10.1109/DSN.2002.1028897>
- [23] Christian Cachin and Marko Vukolić. 2017. Blockchain consensus protocols in the wild. *arXiv preprint arXiv:1707.01873* (2017).
- [24] Ran Canetti. 1996. Studies in secure multiparty computation and applications. *Scientific Council of The Weizmann Institute of Science* (1996).
- [25] Jiayu Cao, Supeng Leng, Lei Zhang, Muhammad Imran, and Haoye Chai. 2022. A V2V Empowered Consensus Framework for Cooperative Autonomous Driving. In *GLOBECOM 2022-2022 IEEE Global Communications Conference*. IEEE, 5729–5734.
- [26] Miguel Castro, Barbara Liskov, et al. 1999. Practical byzantine fault tolerance. In *OSDI*, Vol. 99. 173–186.
- [27] David Cerdeira, Nuno Santos, Pedro Fonseca, and Sandro Pinto. 2020. SoK: Understanding the Prevailing Security Vulnerabilities in TrustZone-assisted TEE Systems. In *2020 IEEE Symposium on Security and Privacy (SP)*. 1416–1432. <https://doi.org/10.1109/SP40000.2020.00061>
- [28] Tushar Deepak Chandra. 1996. Polylog randomized wait-free consensus. In *Proceedings of the fifteenth annual ACM symposium on Principles of distributed computing*. 166–175.
- [29] Tushar Deepak Chandra and Sam Toueg. 1996. Unreliable failure detectors for reliable distributed systems. *Journal of the ACM (JACM)* 43, 2 (1996), 225–267.
- [30] G. V. Chockler, N. Huleihel, and D. Dolev. 1998. An Adaptive Totally Ordered Multicast Protocol That Tolerates Partitions. In *Proceedings of the Seventeenth Annual ACM Symposium on Principles of Distributed Computing (Puerto Vallarta, Mexico) (PODC '98)*. Association for Computing Machinery, New York, NY, USA, 237–246. <https://doi.org/10.1145/277697.277741>
- [31] Usman W Chohan. 2021. Decentralized finance (DeFi): an emergent alternative financial architecture. *Critical Blockchain Research Initiative (CBRI) Working Papers* (2021).
- [32] Byung-Gon Chun, Petros Maniatis, Scott Shenker, and John Kubiatowicz. 2007. Attested append-only memory: Making adversaries stick to their word. *ACM SIGOPS Operating Systems Review* 41, 6 (2007), 189–204.
- [33] Anton Churyumov. 2016. Byteball: A decentralized system for storage and transfer of value. *URL:https://byteball.org/Byteball.pdf* (2016).
- [34] Allen Clement, Flavio Junqueira, Aniket Kate, and Rodrigo Rodrigues. 2012. On the (limited) power of non-equivocation. In *Proceedings of the 2012 ACM symposium on Principles of distributed computing*. 301–308.
- [35] Pierre Cloutier, Paolo Mantegazza, Steve Papacharalambous, Ian Soanes, Stuart Hughes, and Karim Yaghmour. 2000. DIAPM-RTAI position paper, nov 2000. In *Proceedings of the Real-Time Systems Symposium*, Vol. 136.
- [36] Miguel Correia, Nuno Ferreira Neves, and Paulo Verissimo. 2004. How to tolerate half less one Byzantine nodes in practical distributed systems. In *Proceedings of the 23rd IEEE International Symposium on Reliable Distributed Systems, 2004*. IEEE, 174–183.
- [37] Miguel Correia, Nuno Ferreira Neves, and Paulo Verissimo. 2006. From Consensus to Atomic Broadcast: Time-Free Byzantine-Resistant Protocols without Signatures. *Comput. J.* 49, 1 (2006), 82–96. <https://doi.org/10.1093/comjnl/bxh145>
- [38] Miguel Correia, Paulo Verissimo, and Nuno Ferreira Neves. 2002. The Design of a COTS Real-Time Distributed Security Kernel. In *Dependable Computing EDCC-4*, Andrea Bondavalli and Pascale Thevenod-Fosse (Eds.). Springer Berlin Heidelberg, Berlin, Heidelberg, 234–252.
- [39] Miguel Correia, Giuliana Santos Veronese, Nuno Ferreira Neves, and Paulo Verissimo. 2011. Byzantine Consensus in Asynchronous Message-Passing Systems: A Survey. *Int. J. Crit. Comput.-Based Syst.* 2, 2 (jul 2011), 141–161.
- [40] James Cowling, Daniel Myers, Barbara Liskov, Rodrigo Rodrigues, and Liuba Shrira. 2006. HQ replication: A hybrid quorum protocol for Byzantine fault tolerance. In *Proceedings of the 7th symposium on Operating systems design and implementation*. 177–190.
- [41] George Danezis, Lefteris Kokoris-Kogias, Alberto Sonnino, and Alexander Spiegelman. 2022. Narwhal and tusk: a dag-based mempool and efficient bft consensus. In *Proceedings of the Seventeenth European Conference on Computer Systems*. 34–50.

- [42] Christian Decker, Rusty Russell, and Olaoluwa Osuntokun. 2018. eltoo: A simple layer2 protocol for bitcoin. *White paper*. <https://blockstream.com/eltoo.pdf> (2018).
- [43] Yvo Desmedt. 1993. Threshold cryptosystems. In *Advances in Cryptology—AUSCRYPT’92: Workshop on the Theory and Application of Cryptographic Techniques Gold Coast, Queensland, Australia, December 13–16, 1992 Proceedings* 3. Springer, 1–14.
- [44] Tobias Distler. 2021. Byzantine Fault-Tolerant State-Machine Replication from a Systems Perspective. *ACM Comput. Surv.* 54, 1, Article 24 (feb 2021), 38 pages. <https://doi.org/10.1145/3436728>
- [45] Danny Dolev, Shlomo Kramer, and Dalia Malki. 1993. Early delivery totally ordered multicast in asynchronous environments. In *FTCS-23 The Twenty-Third International Symposium on Fault-Tolerant Computing*. IEEE, 544–553.
- [46] Danny Dolev and H Raymond Strong. 1982. Polynomial algorithms for multiple processor agreement. In *Proceedings of the fourteenth annual ACM symposium on Theory of computing*. 401–407.
- [47] John R Douceur. 2002. The sybil attack. In *International workshop on peer-to-peer systems*. Springer, 251–260.
- [48] Assia Doudou, Benoit Garbinato, and Rachid Guerraoui. 2002. Encapsulating failure detection: From crash to byzantine failures. In *Reliable Software Technologies—Ada-Europe 2002: 7th Ada-Europe International Conference on Reliable Software Technologies Vienna, Austria, June 17–21, 2002 Proceedings* 7. Springer, 24–50.
- [49] Sisi Duan, Michael K Reiter, and Haibin Zhang. 2017. Secure causal atomic broadcast, revisited. In *2017 47th Annual IEEE/IFIP International Conference on Dependable Systems and Networks (DSN)*. IEEE, 61–72.
- [50] Sisi Duan, Michael K. Reiter, and Haibin Zhang. 2018. BEAT: Asynchronous BFT Made Practical. In *Proceedings of the 2018 ACM SIGSAC Conference on Computer and Communications Security (Toronto, Canada) (CCS ’18)*. Association for Computing Machinery, New York, NY, USA, 2028–2041. <https://doi.org/10.1145/3243734.3243812>
- [51] Sisi Duan, Xin Wang, and Haibin Zhang. 2023. Practical Signature-Free Asynchronous Common Subset in Constant Time. *Cryptology ePrint Archive* (2023).
- [52] Cynthia Dwork, Nancy Lynch, and Larry Stockmeyer. 1988. Consensus in the presence of partial synchrony. *Journal of the ACM (JACM)* 35, 2 (1988), 288–323.
- [53] Michael Eischer and Tobias Distler. 2017. Scalable Byzantine Fault Tolerance on Heterogeneous Servers. In *2017 13th European Dependable Computing Conference (EDCC)*. 34–41. <https://doi.org/10.1109/EDCC.2017.15>
- [54] Yuqi Fan, Huanan Wu, and Hye-Young Paik. 2021. DR-BFT: A consensus algorithm for blockchain-based multi-layer data integrity framework in dynamic edge computing system. *Future Generation Computer Systems* 124 (2021), 33–48. <https://doi.org/10.1016/j.future.2021.04.020>
- [55] Yixuan Fan, Lei Zhang, Ruiyu Wang, and Muhammad Ali Imran. 2023. Insight into Voting in DAOs: Conceptual Analysis and A Proposal for Evaluation Framework. *IEEE Network* (2023).
- [56] Shufan Fei, Zheng Yan, Wenxiu Ding, and Haomeng Xie. 2021. Security Vulnerabilities of SGX and Countermeasures: A Survey. *ACM Comput. Surv.* 54, 6, Article 126 (jul 2021), 36 pages. <https://doi.org/10.1145/3456631>
- [57] Chenglin Feng, Zhangchen Xu, Xincheng Zhu, Paulo Valente Klaine, and Lei Zhang. 2023. Wireless Distributed Consensus in Vehicle to Vehicle Networks for Autonomous Driving. *IEEE Transactions on Vehicular Technology* 72, 6 (2023), 8061–8073. <https://doi.org/10.1109/TVT.2023.3243995>
- [58] Tiago M Fernández-Caramés and Paula Fraga-Lamas. 2018. A Review on the Use of Blockchain for the Internet of Things. *Ieee Access* 6 (2018), 32979–33001.
- [59] PUB FIPS. 2012. 180-4 Secure Hash Standard (SHS). *US Department of Commerce, National Institute of Standards and Technology (NIST)* (2012).
- [60] Michael J Fischer, Nancy A Lynch, and Michael S Paterson. 1982. Impossibility of distributed consensus with one faulty process. *MIT/LCS/TR-282* (1982). <https://groups.csail.mit.edu/tds/papers/Lynch/MIT-LCS-TR-282.pdf>
- [61] Michael J. Fischer, Nancy A. Lynch, and Michael S. Paterson. 1985. Impossibility of Distributed Consensus with One Faulty Process. *J. ACM* 32, 2 (apr 1985), 374–382. <https://doi.org/10.1145/3149.214121>
- [62] Blockchain for Healthcare. 2021. Retrieved August 30, 2023 from <https://www.hhs.gov/sites/default/files/blockchain-for-healthcare-1pwhite.pdf>
- [63] Blockchains for mass adoption. 2023. Retrieved Sept 2, 2023 from <https://polygon.technology/>
- [64] Keke Gai, Jinnan Guo, Liehuang Zhu, and Shui Yu. 2020. Blockchain meets cloud computing: A survey. *IEEE Communications Surveys & Tutorials* 22, 3 (2020), 2009–2030.
- [65] Ankit Gangwal, Haripriya Raval Gangavalli, and Apoorva Thirupathi. 2023. A survey of Layer-two blockchain protocols. *Journal of Network and Computer Applications* 209 (2023), 103539. <https://doi.org/10.1016/j.jnca.2022.103539>
- [66] Yingzi Gao, Yuan Lu, Zhenliang Lu, Qiang Tang, Jing Xu, and Zhenfeng Zhang. 2022. Dumbo-ng: Fast asynchronous bft consensus with throughput-oblivious latency. In *Proceedings of the 2022 ACM SIGSAC Conference on Computer and Communications Security*. 1187–1201.
- [67] Juan Garay, Aggelos Kiayias, and Nikos Leonardos. 2015. The bitcoin backbone protocol: Analysis and applications. In *Annual international conference on the theory and applications of cryptographic techniques*. Springer, 281–310.
- [68] Yossi Gilad, Rotem Hemo, Silvio Micali, Georgios Vlachos, and Nickolai Zeldovich. 2017. Algorand: Scaling Byzantine Agreements for Cryptocurrencies. In *Proceedings of the 26th Symposium on Operating Systems Principles (Shanghai, China) (SOSP ’17)*. Association for Computing Machinery, New York, NY, USA, 51–68. <https://doi.org/10.1145/3132747.3132757>
- [69] Vincent Gramoli. 2020. From blockchain consensus back to Byzantine consensus. *Future Generation Computer Systems* 107 (2020), 760–769.
- [70] Zhitao Guan, Xiao Zhou, Peng Liu, Longfei Wu, and Wenti Yang. 2021. A blockchain-based dual-side privacy-preserving multiparty computation scheme for edge-enabled smart grid. *IEEE Internet of Things Journal* 9, 16 (2021), 14287–14299.

- [71] Guy Golan Gueta, Ittai Abraham, Shelly Grossman, Dahlia Malkhi, Benny Pinkas, Michael Reiter, Dragos-Adrian Seredinschi, Orr Tamir, and Alin Tomescu. 2019. Sbft: a scalable and decentralized trust infrastructure. In *2019 49th Annual IEEE/IFIP international conference on dependable systems and networks (DSN)*. IEEE, 568–580.
- [72] Bingyong Guo, Zhenliang Lu, Qiang Tang, Jing Xu, and Zhenfeng Zhang. 2020. Dumbo: Faster asynchronous bft protocols. In *Proceedings of the 2020 ACM SIGSAC Conference on Computer and Communications Security*. 803–818.
- [73] James Hendricks, Gregory R Ganger, and Michael K Reiter. 2007. Verifying distributed erasure-coded data. In *Proceedings of the twenty-sixth annual ACM symposium on Principles of distributed computing*. 139–146.
- [74] Zicong Hong, Song Guo, Enyuan Zhou, Jianting Zhang, Wuhui Chen, Jinwen Liang, Jie Zhang, and Albert Zomaya. 2023. Prophet: Conflict-Free Sharding Blockchain via Byzantine-Tolerant Deterministic Ordering. *arXiv preprint arXiv:2304.08595* (2023).
- [75] A.L. Hopkins. 1971. A Fault-Tolerant Information Processing Concept for Space Vehicles. *IEEE Trans. Comput.* C-20, 11 (1971), 1394–1403. <https://doi.org/10.1109/T-C.1971.223145>
- [76] Kenneth Hoyme and Kevin Driscoll. 1992. SAFEbus. In *[1992] Proceedings IEEE/AIAA 11th Digital Avionics Systems Conference*. IEEE, 68–73.
- [77] Patrick Hunt, Mahadev Konar, Flavio P. Junqueira, and Benjamin Reed. 2010. ZooKeeper: Wait-free Coordination for Internet-scale Systems. In *2010 USENIX Annual Technical Conference (USENIX ATC 10)*. USENIX Association. <https://www.usenix.org/conference/usenix-atc-10/zookeeper-wait-free-coordination-internet-scale-systems>
- [78] Ru Huo, Shiqin Zeng, Zhihao Wang, Jiajia Shang, Wei Chen, Tao Huang, Shuo Wang, F. Richard Yu, and Yunjie Liu. 2022. A Comprehensive Survey on Blockchain in Industrial Internet of Things: Motivations, Research Progresses, and Future Challenges. *IEEE Communications Surveys & Tutorials* 24, 1 (2022), 88–122. <https://doi.org/10.1109/COMST.2022.3141490>
- [79] Hyperledger. 2023. Retrieved August 30, 2023 from <https://www.hyperledger.org/>
- [80] Paul R. Johnson and Robert H. Thomas. 1975. Maintenance of duplicate databases. RFC 677. <https://doi.org/10.17487/RFC0677>
- [81] Arthur B Kahn. 1962. Topological sorting of large networks. *Commun. ACM* 5, 11 (1962), 558–562.
- [82] Rüdiger Kapitza, Johannes Behl, Christian Cachin, Tobias Distler, Simon Kuhnle, Seyed Wahid Mohammadi, Wolfgang Schröder-Preikschat, and Klaus Stengel. 2012. CheapBFT: Resource-Efficient Byzantine Fault Tolerance. In *Proceedings of the 7th ACM European Conference on Computer Systems (Bern, Switzerland) (EuroSys '12)*. Association for Computing Machinery, New York, NY, USA, 295–308. <https://doi.org/10.1145/2168836.2168866>
- [83] Manos Kapritsos, Yang Wang, Vivien Quema, Allen Clement, Lorenzo Alvisi, and Mike Dahlin. 2012. All about eve: Execute-verify replication for multi-core servers. In *Presented as part of the 10th {USENIX} Symposium on Operating Systems Design and Implementation ({OSDI} 12)*. 237–250.
- [84] Kolbeinn Karlsson, Weitao Jiang, Stephen Wicker, Danny Adams, Edwin Ma, Robbert van Renesse, and Hakim Weatherspoon. 2018. Vegvisir: A partition-tolerant blockchain for the internet-of-things. In *2018 IEEE 38th International Conference on Distributed Computing Systems (ICDCS)*. IEEE, 1150–1158.
- [85] Maxat Kassen. 2022. Blockchain and e-government innovation: Automation of public information processes. *Information Systems* 103 (2022), 101862. <https://doi.org/10.1016/j.is.2021.101862>
- [86] Idit Keidar, Eleftherios Kokoris-Kogias, Oded Naor, and Alexander Spiegelman. 2021. All You Need is DAG. In *Proceedings of the 2021 ACM Symposium on Principles of Distributed Computing (Virtual Event, Italy) (PODC'21)*. Association for Computing Machinery, New York, NY, USA, 165–175. <https://doi.org/10.1145/3465084.3467905>
- [87] Kim Potter Kihlstrom, Louise E Moser, and P Michael Melliar-Smith. 2003. Byzantine fault detectors for solving consensus. *Comput. J.* 46, 1 (2003), 16–35.
- [88] Valerie King and Jared Saia. 2011. Breaking the O(N²) Bit Barrier: Scalable Byzantine Agreement with an Adaptive Adversary. *J. ACM* 58, 4, Article 18 (jul 2011), 24 pages. <https://doi.org/10.1145/1989727.1989732>
- [89] Eleftherios Kokoris Kogias, Philipp Jovanovic, Nicolas Gailly, Ismail Khoffi, Linus Gasser, and Bryan Ford. 2016. Enhancing bitcoin security and performance with strong consistency via collective signing. In *25th usenix security symposium (usenix security 16)*. 279–296.
- [90] Eleftherios Kokoris-Kogias, Philipp Jovanovic, Linus Gasser, Nicolas Gailly, Ewa Syta, and Bryan Ford. 2018. OmniLedger: A Secure, Scale-Out, Decentralized Ledger via Sharding. In *2018 IEEE Symposium on Security and Privacy (SP)*. 583–598. <https://doi.org/10.1109/SP.2018.000-5>
- [91] Xiangjie Kong, Yuhan Wu, Hui Wang, and Feng Xia. 2022. Edge Computing for Internet of Everything: A Survey. *IEEE Internet of Things Journal* 9, 23 (2022), 23472–23485. <https://doi.org/10.1109/JIOT.2022.3200431>
- [92] Hermann Kopetz and Günter Grunsteidl. 1993. TTP-A time-triggered protocol for fault-tolerant real-time systems. In *FTCS-23 The twenty-third international symposium on fault-tolerant computing*. IEEE, 524–533.
- [93] Ramakrishna Kotla, Lorenzo Alvisi, Mike Dahlin, Allen Clement, and Edmund Wong. 2010. Zyzzyva: Speculative Byzantine Fault Tolerance. 27, 4 (2010). <https://doi.org/10.1145/1658357.1658358>
- [94] Ramakrishna Kotla and Michael Dahlin. 2004. High throughput Byzantine fault tolerance. In *International Conference on Dependable Systems and Networks, 2004*. IEEE, 575–584.
- [95] Ji-Young Kwak, Jongchoul Yim, Nam-Seok Ko, and Sun-Me Kim. 2020. The Design of Hierarchical Consensus Mechanism Based on Service-Zone Sharding. *IEEE Transactions on Engineering Management* 67, 4 (2020), 1387–1403. <https://doi.org/10.1109/TEM.2020.2993413>
- [96] Leslie Lamport. 1978. Time, Clocks, and the Ordering of Events in a Distributed System. *Commun. ACM* 21, 7 (jul 1978), 558–565. <https://doi.org/10.1145/359545.359563>
- [97] Leslie Lamport. 1979. How to make a multiprocessor computer that correctly executes multiprocess programs. *IEEE Transactions on Computers* c-28 9 (1979), 690–691.

- [98] Leslie Lamport. 1998. The Part-Time Parliament. *ACM Transactions on Computer Systems* 16, 2 (1998), 133–169.
- [99] Leslie Lamport. 2005. Generalized consensus and Paxos. (2005).
- [100] Leslie Lamport, Robert Shostak, and Marshall Pease. 1982. The Byzantine Generals Problem. *ACM Transactions on Programming Languages and Systems* 4, 3 (1982), 382–401.
- [101] Yoad Lewenberg, Yonatan Sompolinsky, and Aviv Zohar. 2015. Inclusive block chain protocols. In *Financial Cryptography and Data Security: 19th International Conference, FC 2015, San Juan, Puerto Rico, January 26–30, 2015, Revised Selected Papers 19*. Springer, 528–547.
- [102] Chunlin Li, Jing Zhang, Xianmin Yang, and Luo Youlong. 2021. Lightweight blockchain consensus mechanism and storage optimization for resource-constrained IoT devices. *Information Processing & Management* 58, 4 (2021), 102602. <https://doi.org/10.1016/j.ipm.2021.102602>
- [103] Wenyu Li, Chenglin Feng, Lei Zhang, Hao Xu, Bin Cao, and Muhammad Ali Imran. 2021. A Scalable Multi-Layer PBFT Consensus for Blockchain. *IEEE Transactions on Parallel and Distributed Systems* 32, 5 (2021), 1146–1160. <https://doi.org/10.1109/TPDS.2020.3042392>
- [104] Zhongmiao Li, Peter Van Roy, and Paolo Romano. 2017. Enhancing throughput of partially replicated state machines via multi-partition operation scheduling. In *2017 IEEE 16th International Symposium on Network Computing and Applications (NCA)*. IEEE, 1–10.
- [105] Chao Liu, Sisi Duan, and Haibin Zhang. 2020. Epic: Efficient asynchronous bft with adaptive security. In *2020 50th Annual IEEE/IFIP International Conference on Dependable Systems and Networks (DSN)*. IEEE, 437–451.
- [106] Chao Liu, Sisi Duan, and Haibin Zhang. 2021. MiB: Asynchronous BFT with more replicas. *arXiv preprint arXiv:2108.04488* (2021).
- [107] Chi Harold Liu, Qiuxia Lin, and Shilin Wen. 2019. Blockchain-Enabled Data Collection and Sharing for Industrial IoT With Deep Reinforcement Learning. *IEEE Transactions on Industrial Informatics* 15, 6 (2019), 3516–3526. <https://doi.org/10.1109/TII.2018.2890203>
- [108] Nancy A. Lynch. 1996. *Distributed Algorithms*. Morgan Kaufmann Publishers Inc., San Francisco, CA, USA.
- [109] Dahlia Malkhi. 2019. *Concurrency: the works of Leslie Lamport*. ACM.
- [110] Dahlia Malkhi and Michael Reiter. 1997. Unreliable intrusion detection in distributed computations. In *Proceedings 10th Computer Security Foundations Workshop*. IEEE, 116–124.
- [111] Abdullah Al Mamun, Sami Azam, and Clementine Gritti. 2022. Blockchain-Based Electronic Health Records Management: A Comprehensive Review and Future Research Direction. *IEEE Access* 10 (2022), 5768–5789. <https://doi.org/10.1109/ACCESS.2022.3141079>
- [112] Silvio Micali, Michael Rabin, and Salil Vadhan. 1999. Verifiable random functions. In *40th annual symposium on foundations of computer science (cat. No. 99CB37039)*. IEEE, 120–130.
- [113] Andrew Miller, Yu Xia, Kyle Croman, Elaine Shi, and Dawn Song. 2016. The honey badger of BFT protocols. In *Proceedings of the 2016 ACM SIGSAC conference on computer and communications security*. 31–42.
- [114] Iulian Moraru, David G Andersen, and Michael Kaminsky. 2013. There is more consensus in egalitarian parliaments. In *Proceedings of the Twenty-Fourth ACM Symposium on Operating Systems Principles*. 358–372.
- [115] Matthieu Nadini, Laura Alessandretti, Flavio Di Giacinto, Mauro Martino, Luca Maria Aiello, and Andrea Baronchelli. 2021. Mapping the NFT revolution: market trends, trade networks, and visual features. *Scientific reports* 11, 1 (2021), 20902.
- [116] Satoshi Nakamoto. 2008. Bitcoin: A Peer-to-Peer Electronic Cash System. <https://bitcoin.org/bitcoin.pdf> Accessed: 2023-03-16.
- [117] Valeri Natanelov, Shoufeng Cao, Marcus Foth, and Uwe Dulleck. 2022. Blockchain smart contracts for supply chain finance: Mapping the innovation potential in Australia-China beef supply chains. *Journal of Industrial Information Integration* 30 (2022), 100389. <https://doi.org/10.1016/j.jii.2022.100389>
- [118] Christopher Natoli, Jiangshan Yu, Vincent Gramoli, and Paulo Esteves-Verissimo. 2019. Deconstructing blockchains: A comprehensive survey on consensus, membership and structure. *arXiv preprint arXiv:1908.08316* (2019).
- [119] Ray Neiheiser, Miguel Matos, and Luis Rodrigues. 2021. Kauri: Scalable BFT Consensus with Pipelined Tree-Based Dissemination and Aggregation. In *Proceedings of the ACM SIGOPS 28th Symposium on Operating Systems Principles (Virtual Event, Germany) (SOSP '21)*. Association for Computing Machinery, New York, NY, USA, 35–48. <https://doi.org/10.1145/3477132.3483584>
- [120] Dinh C Nguyen, Pubudu N Pathirana, Ming Ding, and Aruna Seneviratne. 2019. Blockchain for secure ehds sharing of mobile cloud based e-health systems. *IEEE access* 7 (2019), 66792–66806.
- [121] University of Washington. 2020. SAFETY, LIVENESS, AND CONSISTENCY. <https://courses.cs.washington.edu/courses/cse452/20sp/slides/consistency.pdf>. Accessed: 2024-07-28.
- [122] Diego Ongaro and John Ousterhout. 2014. In search of an understandable consensus algorithm. In *2014 USENIX Annual Technical Conference (Usenix ATC 14)*. 305–319.
- [123] OpenIDL. 2023. OpenIDL: an open blockchain network for insurers. Retrieved August 30, 2023 from <https://openidl.org/>
- [124] Fernando Pedone, André Schiper, Péter Urbán, and David Cavin. 2002. Solving agreement problems with weak ordering oracles. In *Dependable Computing EDCC-4: 4th European Dependable Computing Conference Toulouse, France, October 23–25, 2002 Proceedings 4*. Springer, 44–61.
- [125] Joseph Poon and Thaddeus Dryja. 2015. The bitcoin lightning network. *Scalable o-chain instant payments* (2015), 20–46.
- [126] DSCSA Pilot Project Program. 2023. Retrieved August 31, 2023 from <https://www.fda.gov/drugs/drug-supply-chain-security-act-dscsa/dscsa-pilot-project-program>
- [127] Zhiguo Qu, Zhexi Zhang, and Min Zheng. 2022. A quantum blockchain-enabled framework for secure private electronic medical records in Internet of Medical Things. *Information Sciences* 612 (2022), 942–958. <https://doi.org/10.1016/j.ins.2022.09.028>
- [128] RippleNet. 2023. Ripple: Crypto Solutions for Business. Retrieved August 30, 2023 from <https://ripple.com/>
- [129] John Rushby. 2001. Bus architectures for safety-critical embedded systems. In *International Workshop on Embedded Software*. Springer, 306–323.

- [130] Carlos Santana and Laura Albareda. 2022. Blockchain and the emergence of Decentralized Autonomous Organizations (DAOs): An integrative model and research agenda. *Technological Forecasting and Social Change* 182 (2022), 121806.
- [131] Ayelet Sapirshstein, Yonatan Sompolinsky, and Aviv Zohar. 2016. Optimal selfish mining strategies in bitcoin. In *International Conference on Financial Cryptography and Data Security*. Springer, 515–532.
- [132] Fred B Schneider. 1990. Implementing fault-tolerant services using the state machine approach: A tutorial. *ACM Computing Surveys (CSUR)* 22, 4 (1990), 299–319.
- [133] Marc Shapiro, Nuno Preguiça, Carlos Baquero, and Marek Zawirski. 2011. Conflict-free replicated data types. In *Stabilization, Safety, and Security of Distributed Systems: 13th International Symposium, SSS 2011, Grenoble, France, October 10–12, 2011. Proceedings 13*. Springer, 386–400.
- [134] Elaine Shi. 2020. Foundations of distributed consensus and blockchains. *Book manuscript* (2020).
- [135] Yonatan Sompolinsky and Aviv Zohar. 2018. Phantom, ghostdag: Two scalable blockdag protocols. *IACR Cryptol. ePrint Arch.* (2018).
- [136] Qun Song, Yuhao Chen, Yan Zhong, Kun Lan, Simon Fong, and Rui Tang. 2021. A Supply-Chain System Framework Based on Internet of Things Using Blockchain Technology. *ACM Trans. Internet Technol.* 21, 1, Article 13 (jan 2021), 24 pages. <https://doi.org/10.1145/3409798>
- [137] Alexander Spiegelman, Neil Giridharan, Alberto Sonnino, and Lefteris Kokoris-Kogias. 2022. Bullshark: DAG BFT Protocols Made Practical. In *Proceedings of the 2022 ACM SIGSAC Conference on Computer and Communications Security (Los Angeles, CA, USA) (CCS '22)*. Association for Computing Machinery, New York, NY, USA, 2705–2718. <https://doi.org/10.1145/3548606.3559361>
- [138] Chrysoula Stathakopoulou, Tudor David, Matej Pavlovic, and Marko Vukolić. 2019. Mir-bft: High-throughput robust bft for decentralized networks. *arXiv preprint arXiv:1906.05552* (2019).
- [139] Chrysoula Stathakopoulou, Matej Pavlovic, and Marko Vukolić. 2022. State Machine Replication Scalability Made Simple. In *Proceedings of the Seventeenth European Conference on Computer Systems (Rennes, France) (EuroSys '22)*. Association for Computing Machinery, New York, NY, USA, 17–33. <https://doi.org/10.1145/3492321.3519579>
- [140] Ilya Sukhodol'skiy and Sergey Zapechnikov. 2018. A blockchain-based access control system for cloud storage. In *2018 IEEE Conference of Russian Young Researchers in Electrical and Electronic Engineering (ELConRus)*. IEEE, 1575–1578.
- [141] UCLA-LedgerDomain: DSCSA Solution Through Blockchain Technology. 2023. Retrieved August 31, 2023 from <https://www.fda.gov/media/168293/download>
- [142] Giuliana Santos Veronese, Miguel Correia, Alysso Neves Bessani, Lau Cheuk Lung, and Paulo Verissimo. 2011. Efficient byzantine fault-tolerance. *IEEE Trans. Comput.* 62, 1 (2011), 16–30.
- [143] Qin Wang, Rujia Li, Qi Wang, and Shiping Chen. 2021. Non-fungible token (NFT): Overview, evaluation, opportunities and challenges. *arXiv preprint arXiv:2105.07447* (2021).
- [144] Xin Wang, Sisi Duan, James Clavin, and Haibin Zhang. 2022. Bft in blockchains: From protocols to use cases. *ACM Computing Surveys (CSUR)* 54, 10s (2022), 1–37.
- [145] Xu Wang, Guangsheng Yu, Ren Ping Liu, Jian Zhang, Qiang Wu, Steven W. Su, Ying He, Zongjian Zhang, Litao Yu, Taoping Liu, Wentian Zhang, Peter Loneragan, Eryk Dutkiewicz, Erik Poole, and Nick Paton. 2022. Blockchain-Enabled Fish Provenance and Quality Tracking System. *IEEE Internet of Things Journal* 9, 11 (2022), 8130–8142. <https://doi.org/10.1109/JIOT.2021.3109313>
- [146] Roger Wattenhofer. 2019. *Blockchain science: Distributed ledger technology*. Inverted Forest Publishing.
- [147] J.H. Wensley, L. Lamport, J. Goldberg, M.W. Green, K.N. Levitt, P.M. Melliar-Smith, R.E. Shostak, and C.B. Weinstock. 1978. SIFT: Design and analysis of a fault-tolerant computer for aircraft control. *Proc. IEEE* 66, 10 (1978), 1240–1255. <https://doi.org/10.1109/PROC.1978.11114>
- [148] Sam Werner, Daniel Perez, Lewis Gudgeon, Arian Klages-Mundt, Dominik Harz, and William Knottenbelt. 2022. Sok: Decentralized finance (defi). In *Proceedings of the 4th ACM Conference on Advances in Financial Technologies*. 30–46.
- [149] Gavin Wood. 2014. Ethereum: A secure decentralised generalised transaction ledger. (2014).
- [150] Huanyu Wu, Lunjie Li, Hye-young Paik, and Salil S. Kanhere. 2021. MB-EHR: A Multilayer Blockchain-based EHR. In *2021 IEEE International Conference on Blockchain and Cryptocurrency (ICBC)*. 1–3. <https://doi.org/10.1109/ICBC51069.2021.9461075>
- [151] Huan Yu Wu, Lun Jie Li, Hye-Young Paik, and Salil S. Kanhere. 2021. MEChain: A Multi-layer Blockchain Structure with Hierarchical Consensus for Secure EHR System. In *2021 IEEE 20th International Conference on Trust, Security and Privacy in Computing and Communications (TrustCom)*. 976–987. <https://doi.org/10.1109/TrustCom53373.2021.00136>
- [152] Huan Yu Wu, Xin Yang, Chentao Yue, Hye-Young Paik, and Salil S. Kanhere. 2022. Chain or DAG? Underlying data structures, architectures, topologies and consensus in distributed ledger technology: A review, taxonomy and research issues. *Journal of Systems Architecture* 131 (2022), 102720. <https://doi.org/10.1016/j.sysarc.2022.102720>
- [153] Yang Xiao, Ning Zhang, Wenjing Lou, and Y Thomas Hou. 2020. A survey of distributed consensus protocols for blockchain networks. *IEEE Communications Surveys & Tutorials* 22, 2 (2020), 1432–1465.
- [154] Hao Xu, Yixuan Fan, Wenyu Li, and Lei Zhang. 2022. Wireless distributed consensus for connected autonomous systems. *IEEE Internet of Things Journal* (2022).
- [155] Ruizhe Yang, F. Richard Yu, Pengbo Si, Zhaoxin Yang, and Yanhua Zhang. 2019. Integrated Blockchain and Edge Computing Systems: A Survey, Some Research Issues and Challenges. *IEEE Communications Surveys & Tutorials* 21, 2 (2019), 1508–1532. <https://doi.org/10.1109/COMST.2019.2894727>
- [156] Maofan Yin, Dahlia Malkhi, Michael K. Reiter, Guy Golan Gueta, and Ittai Abraham. 2019. HotStuff: BFT Consensus with Linearity and Responsiveness. In *Proceedings of the 2019 ACM Symposium on Principles of Distributed Computing (Toronto ON, Canada) (PODC '19)*. Association for Computing Machinery, New York, NY, USA, 347–356. <https://doi.org/10.1145/3293611.3331591>

- [157] Gengrui Zhang, Fei Pan, Yunhao Mao, Sofia Tijanic, Michael Dang'ana, Shashank Motepalli, Shiquan Zhang, and Hans-Arno Jacobsen. 2024. Reaching consensus in the byzantine empire: A comprehensive review of bft consensus algorithms. *Comput. Surveys* 56, 5 (2024), 1–41.
- [158] Gengrui Zhang, Fei Pan, Sofia Tijanic, and Hans-Arno Jacobsen. 2023. PrestigeBFT: Revolutionizing View Changes in BFT Consensus Algorithms with Reputation Mechanisms. *arXiv preprint arXiv:2307.08154* (2023).
- [159] Lei Zhang, Hao Xu, Oluwakayode Onireti, Muhammad Ali Imran, and Bin Cao. 2021. How much communication resource is needed to run a wireless blockchain network? *IEEE network* 36, 1 (2021), 128–135.
- [160] Yuanyu Zhang, Shoji Kasahara, Yulong Shen, Xiaohong Jiang, and Jianxiong Wan. 2018. Smart contract-based access control for the internet of things. *IEEE Internet of Things Journal* 6, 2 (2018), 1594–1605.
- [161] Li Zongyao, Lei Zhang, Xiaoshuai Zhang, and Muhammad Imran. 2022. Design and Implementation of a Raft based Wireless Consensus System for Autonomous Driving. (2022).

Received 20 February 2007; revised 12 March 2009; accepted 5 June 2009