

Possibilistic and maximal indefinite causal order in the quantum switch

Tein van der Lugt and Nick Ormrod

Department of Computer Science, University of Oxford, Wolfson Building, Parks Road, Oxford, OX1 3QD, United Kingdom

It was recently found that the indefinite causal order in the quantum switch can be certified device-independently when assuming the impossibility of superluminal influences. Here we strengthen this result in two ways. First, we give a proof of this fact which is possibilistic, rather than probabilistic, i.e. which does not rely on the validity of probability theory at the hidden variable level. Then, returning to the probabilistic setting, we show that the indefinite causal order in the quantum switch is also maximal, in the sense that the observed correlations are incompatible even with the existence of a causal order on only a small fraction of the runs of the experiment. While the original result makes use of quantum theory’s violation of a Clauser-Horne-Shimony-Holt inequality, the proofs presented here are based on Greenberger, Horne, and Zeilinger’s and Mermin’s proofs of nonlocality, respectively.

When two measurements are performed within a quantum circuit, the topology of the circuit puts constraints on the causal relations between them: either the choice of measurement at A can influence the outcome of the measurement at B , or vice versa, but not both. Recent extensions to the quantum circuit paradigm have however facilitated considering situations in which the topology of the quantum circuit itself, and in particular the causal order between measurements, is in a quantum superposition. The simplest example of this is the *quantum switch* [1], a mathematical device that applies two operations to a target system in an order coherently controlled by the state of a qubit.

It was recently found that under some metaphysical assumptions, the indefinite causal order between measurements in the quantum switch can also be demonstrated device-independently, that is, relying just on correlations between classical settings and outcomes of the measurements, and not on a characterisation of the measurements themselves (or indeed the assumption that they are governed by quantum theory) [2, 3]. The argument of [2] works via the violation of an inequality derived from assumptions named definite causal order, relativistic causality, and free interventions. This derivation relies closely on Bell’s theorem [4]: the crucial observation is that a hidden

variable determining a causal order (which exists by the first assumption) in some particular cases must also fix, or, in other words, ‘predetermine’, a measurement outcome—and that this determinism, together with the other assumptions, implies Bell inequalities which are violated by the quantum correlations under consideration.

This observation suggests that it is possible to transform other proofs of Bell nonlocality, beyond that based on the Clauser-Horne-Shimony-Holt (CHSH) inequality employed in [2], into proofs of indefinite causal order in the quantum switch. Here we give a proof in the style of Mermin’s version of Greenberger-Horne-Zeilinger (GHZ) nonlocality [5–7]. Similarly to the latter, the proof does not involve inequalities and is of a possibilistic, rather than probabilistic, character: the quantum switch data are shown to contradict the assumptions mentioned above even when both are formulated merely in terms of which events have zero and nonzero probabilities. In particular this shows that the quantum switch is incompatible with a (relativistically well-behaved) definite causal order even if causal orders are not required to follow the laws of probability theory.

We also give a statistical inequality, analogous to Mermin’s inequality [8] for Bell nonlocality, which parallels our possibilistic argument. Although this takes us back to assuming the validity of probability theory, it allows us to improve on the results of [2, 3] in a different way, namely by showing that the quantum switch exhibits ‘maximal’ indefinite causal order. More precisely, the quantum switch correlations violate this inequality to the algebraic maximum, which implies incompatibility even with the hypothesis that there is a definite causal order on only some positive fraction of the runs of the experiment.

1 Notation and terminology

Possibilities are modelled by the Boolean semiring $\mathbb{B} = \{0, 1\}$, where 0 denotes impossibility and 1 possibility of an event. Addition and multiplication in \mathbb{B} are defined as $0 + 0 = 0$, $0 + 1 = 1 + 0 = 1 + 1 = 1$, $0 \cdot 0 = 0 \cdot 1 = 1 \cdot 0 = 0$ and $1 \cdot 1 = 1$. A *possibility distribution* over a set of variables a_1, \dots, a_n taking values in the finite sets A_1, \dots, A_n is a function $p : A_1 \times \dots \times A_n \rightarrow \mathbb{B}$ satisfying $\sum_{a_1, \dots, a_n} p(a_1 \dots a_n) = 1$;

Tein van der Lugt: tein.van.der.lugt@cs.ox.ac.uk

Nick Ormrod: nicholas.ormrod@cs.ox.ac.uk

arXiv:2311.00557v1 [quant-ph] 1 Nov 2023

i.e. at least one tuple of values is possible. (We will abuse notation by using lower-case letters to denote random variables as well as their values.) A *probability distribution* $P : A \rightarrow \mathbb{R}_{\geq 0}$ defines a possibility distribution p over the same variable by $p(a) = \pi(P(a))$, where $\pi : \mathbb{R}_{\geq 0} \rightarrow \mathbb{B}$ takes 0 to 0 and any $r > 0$ to 1.

(Conditional) independence is denoted by $\perp\!\!\!\perp$. In the case of a possibility distribution $p(abc)$, $a \perp\!\!\!\perp b \mid c$ is defined as $\forall a, b, c : p(abc) = p(ac)p(bc)$, while unconditional independence $a \perp\!\!\!\perp b$ means that $\forall a, b : p(ab) = p(a)p(b)$. Moreover, \implies denotes implication: for propositions P and Q , $P \implies_p Q$ is short for $p(P, \neg Q) = 0$.

Finally, \oplus denotes addition modulo 2, and $|\pm\rangle := (|0\rangle \pm |1\rangle)/\sqrt{2}$ and $|\pm i\rangle := (|0\rangle \pm i|1\rangle)/\sqrt{2}$.

2 GHZ-Mermin nonlocality

We first review Mermin's version [6] of the GHZ proof [5] of Bell nonlocality. Three spacelike-separated parties labelled A , B , and C share three qubits prepared in the state $|\text{GHZ}\rangle := (|000\rangle + |111\rangle)/\sqrt{2}$. Each party has a binary classical input variable ($x, y, z \in \{0, 1\}$, resp.), and measures their qubit in the Y basis $\{|+i\rangle, |-i\rangle\}$ if their input is 0, and in the X basis $\{|+\rangle, |-\rangle\}$ if their input is 1. The measurement outcomes are recorded in the output variables $a, b, c \in \{0, 1\}$. Given a probability distribution over the input variables, the Born rule provides joint probabilities $P(abcxyz)$ for all combinations of input and output variables. All that the following argument relies on are however the induced *possibilities* $p(abcxyz) := \pi(P(abcxyz))$.

A particular property of these possibilities, predicted by the Born rule, is that

$$\begin{aligned} x = 1, y = 1, z = 1 &\implies_p a \oplus b \oplus c = 0; \\ x = 1, y = 0, z = 0 &\implies_p a \oplus b \oplus c = 1; \\ x = 0, y = 1, z = 0 &\implies_p a \oplus b \oplus c = 1; \\ \text{and } x = 0, y = 0, z = 1 &\implies_p a \oplus b \oplus c = 1. \end{aligned} \quad (1)$$

These perfect correlations can be used in an EPR-like argument [9] to argue for the existence of local deterministic hidden variables, i.e. to argue that for each wing of the experiment, there are pre-existing physical properties that determine the outcome for any possible measurement setting on that wing. Mathematically, these are described by variables $\lambda_{A,B,C}^{0,1} \in \{0, 1\}$, independent of x, y, z and satisfying $x = i \implies_p a = \lambda_A^i$ and similar conditions for B and C .

Together with the assumption that all combinations of inputs appearing in (1) are in fact possible, this

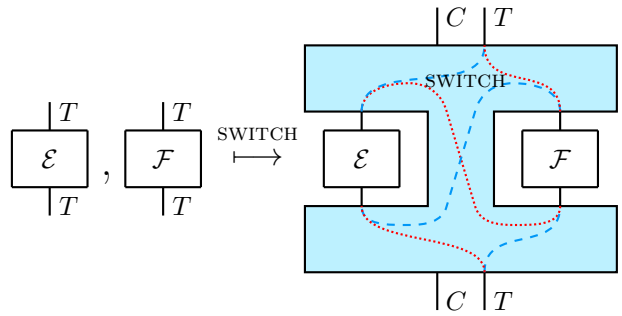

Figure 1: The quantum switch takes two quantum operations on the system T , here \mathcal{E} and \mathcal{F} , to an operation on CT , where C is a control qubit. The dotted (red) and dashed (blue) lines illustrate the wirings to which the quantum switch reduces upon preparation of C in state $|+\rangle|+\rangle$ and $|-\rangle|-\rangle$, respectively.

leads us to conclude that with certainty

$$\begin{aligned} \lambda_A^1 \oplus \lambda_B^1 \oplus \lambda_C^1 &= 0; \\ \lambda_A^1 \oplus \lambda_B^0 \oplus \lambda_C^0 &= 1; \\ \lambda_A^0 \oplus \lambda_B^1 \oplus \lambda_C^0 &= 1; \\ \lambda_A^0 \oplus \lambda_B^0 \oplus \lambda_C^1 &= 1; \oplus \\ \hline &0 = 1. \end{aligned} \quad (2)$$

This contradiction demonstrates that no model with local deterministic hidden variables $\lambda_{A,B,C}^{0,1}$ can reproduce the correlations (1) predicted by the Born rule.

3 Adding switches

We will now see how this argument can be turned into a possibilistic proof of indefinite causal order in the quantum switch. Our first objective will be to identify a scenario involving quantum switches that yields possibilistic data satisfying properties analogous to (1) above.

The quantum switch [1] is defined as a supermap [10] taking two quantum operations \mathcal{E}, \mathcal{F} on a *target system* T to an operation $\text{SWITCH}(\mathcal{E}, \mathcal{F})$ on the joint system CT , which applies \mathcal{E} and \mathcal{F} to T in an order that is coherently controlled by the state of the *control qubit* C (see Figure 1). We will consider a variant of the quantum switch which is controlled in the X basis $\{|+\rangle, |-\rangle\}$. Hence, if the target and control systems are described by Hilbert spaces \mathcal{H}_T and $\mathcal{H}_C \cong \mathbb{C}^2$ and if $\mathcal{E}(\cdot) = E(\cdot)E^\dagger$ and $\mathcal{F}(\cdot) = F(\cdot)F^\dagger$ are pure operations with Kraus operators $E, F : \mathcal{H}_T \rightarrow \mathcal{H}_T$, then $\text{SWITCH}(\mathcal{E}, \mathcal{F})(\cdot) = W(\cdot)W^\dagger$ where $W : \mathcal{H}_C \otimes \mathcal{H}_T \rightarrow \mathcal{H}_C \otimes \mathcal{H}_T$ is the operator defined by

$$W := |+\rangle \langle +|_C \otimes FE + |-\rangle \langle -|_C \otimes EF. \quad (3)$$

We consider a scenario in which three such quantum switches, labelled by A , B and C , are implemented at spacelike-separated locations. Their control qubits

are prepared in the GHZ state, while their target systems, also qubits, are all prepared in the state $|0\rangle$ (see Figure 2). We will think of the two operations on the target system T_A inside switch A as being performed by two agents, \mathcal{A}_1 and \mathcal{A}_2 , with classical input variables $x_1, x_2 \in \{0, 1\}$ and output variables $a, b \in \{0, 1\}$, respectively. If $x_i = 0$ (for $i = 1, 2$), then \mathcal{A}_i performs no intervention (i.e. lets T_A undergo the identity channel), and outputs $a_i = 0$. If $x_i = 1$, she instead measures T_A in the computational basis, records the result in $a_i \in \{0, 1\}$, and prepares the outgoing target system in state $|1\rangle_{T_A}$. A third agent \mathcal{A}_3 has no input variable and always measures the output control system C_A in the Y basis, recording their result in the output variable $a_3 \in \{0, 1\}$. Similar measurements are performed on the systems of switches B and C .

The Born rule, together with the definition of the quantum switch (3) and a distribution over input variables, provides us with a probability distribution $Q(a_1 a_2 a_3 b_1 b_2 b_3 c_1 c_2 c_3 x_1 x_2 y_1 y_2 z_1 z_2)$ (see Appendix A for a more precise definition). We will abbreviate this by $Q(\mathbf{abcxyz})$ where $\mathbf{a} := (a_1, a_2, a_3)$, $\mathbf{x} := (x_1, x_2)$ and $\mathbf{b}, \mathbf{c}, \mathbf{y}$, and \mathbf{z} are defined similarly. As was the case for GHZ nonlocality, it will suffice to consider only the induced possibility distribution $q(\mathbf{abcxyz}) := \pi(Q(\mathbf{abcxyz}))$.

We now want to find patterns in these possibilities analogous to those in (1). For that purpose, the following two observations will be useful (cf. Figure 3). (These informal statements are given to provide intuition; formalised versions and their proofs can be found as Lemmas 2 and 3 in Appendix A.)

Observation 1. If $x_1 = x_2 = 0$, then a_3 simulates the outcome of a Y basis measurement of the *input* control system C_A ; similarly for switches B and C .

Indeed, when $x_1 = x_2 = 0$, no interventions are performed on the target system inside the switch, so that the switch itself reduces to the identity channel. This leaves the control system unaffected for \mathcal{A}_3 to measure (see Figure 3a).

Observation 2. If $x_1 = x_2 = 1$, then a_1 simulates the outcome of an X basis measurement of the input control system C_A ; similarly for switches B and C .

This is because the input target system is initially prepared in state $|0\rangle_{T_A}$, while \mathcal{A}_2 (given $x_2 = 1$) prepares it in the orthogonal state $|1\rangle_{T_A}$. As a result, a measurement of $a_1 = 1$ is only compatible with the wiring in which \mathcal{A}_1 comes after \mathcal{A}_2 —and therefore only with finding the control qubit in state $|-\rangle_{C_A}$ upon an X basis measurement. Similarly, $a_1 = 0$ is only compatible with the control qubit being found in state $|+\rangle_{C_A}$. Therefore the probabilities (and hence possibilities) of these events are identical. This is depicted diagrammatically in Figure 3b and proven in Appendix A.

Observations 1 and 2, together with the fact that the control qubits are entangled in the GHZ state, tell

us that if we make appropriate changes to the variables featuring in (1) then the resulting implications will hold in our new possibility distribution q :

$$\begin{aligned} \mathbf{x} = \mathbf{1}, \mathbf{y} = \mathbf{1}, \mathbf{z} = \mathbf{1} &\implies_q a_1 \oplus b_1 \oplus c_1 = 0; \\ \mathbf{x} = \mathbf{1}, \mathbf{y} = \mathbf{0}, \mathbf{z} = \mathbf{0} &\implies_q a_1 \oplus b_3 \oplus c_3 = 1; \\ \mathbf{x} = \mathbf{0}, \mathbf{y} = \mathbf{1}, \mathbf{z} = \mathbf{0} &\implies_q a_3 \oplus b_1 \oplus c_3 = 1; \\ \mathbf{x} = \mathbf{0}, \mathbf{y} = \mathbf{0}, \mathbf{z} = \mathbf{1} &\implies_q a_3 \oplus b_3 \oplus c_1 = 1 \end{aligned} \quad (4)$$

(here $\mathbf{0} := (0, 0)$ and $\mathbf{1} := (1, 1)$). (It is worth noting that these implications are nothing more than properties of the possibility distribution q and can therefore also be derived directly from the Born rule and definition of the quantum switch. Observations 1 and 2 are only given to provide intuition for why (4) should hold, given that we already know the GHZ correlations of (1).)

The implications in (4), like those in (1), do not immediately lead to a contradiction, because each equation on the right refers to outputs for a different set of inputs. As in the case of nonlocality, a contradiction only arises when some of the outcome variables can be replaced by (hidden) variables that are independent of these measurement choices. The next sections show that the assumptions of definite causal order and relativistic causality imply the existence of such variables.

4 Definite causal order

In the following we will want to probe causal relations on the basis of (possibilistic) correlations. An important assumption enabling this is that the input variables $x_1, x_2, y_1, y_2, z_1, z_2$ of the agents' interventions are freely chosen. In particular, this means that they are uncorrelated with variables outside their causal future, motivating some of the mathematical conditions defined below. It also motivates the assumption that all inputs are jointly possible, which will be needed later:

$$\forall \mathbf{x}, \mathbf{y}, \mathbf{z} \quad q(\mathbf{xyz}) = 1. \quad (5)$$

Definition 1. A *hidden causal order model* for a possibility distribution $r(a_1 a_2 x_1 x_2)$ is a possibility distribution $r(a_1 a_2 x_1 x_2 \lambda)$, where $\lambda \in \{0, 1\}$, such that

$$\sum_{\lambda} r(a_1 a_2 x_1 x_2 \lambda) = r(a_1 a_2 x_1 x_2), \quad (6a)$$

$$\lambda \perp\!\!\!\perp_r x_1 x_2, \quad (6b)$$

$$a_1 \perp\!\!\!\perp_r x_2 \mid \lambda = 0, \quad (6c)$$

$$\text{and } a_2 \perp\!\!\!\perp_r x_1 \mid \lambda = 1. \quad (6d)$$

The interpretation of this hidden variable λ is that it determines the causal order between interventions performed by parties \mathcal{A}_1 and \mathcal{A}_2 with inputs x_1, x_2 and outputs a_1, a_2 , respectively: viz. the value $\lambda = 0$ indicates that \mathcal{A}_1 acts outside the causal future of \mathcal{A}_2 , so that the possibility of outcome a_1 is independent of the freely chosen input x_2 .

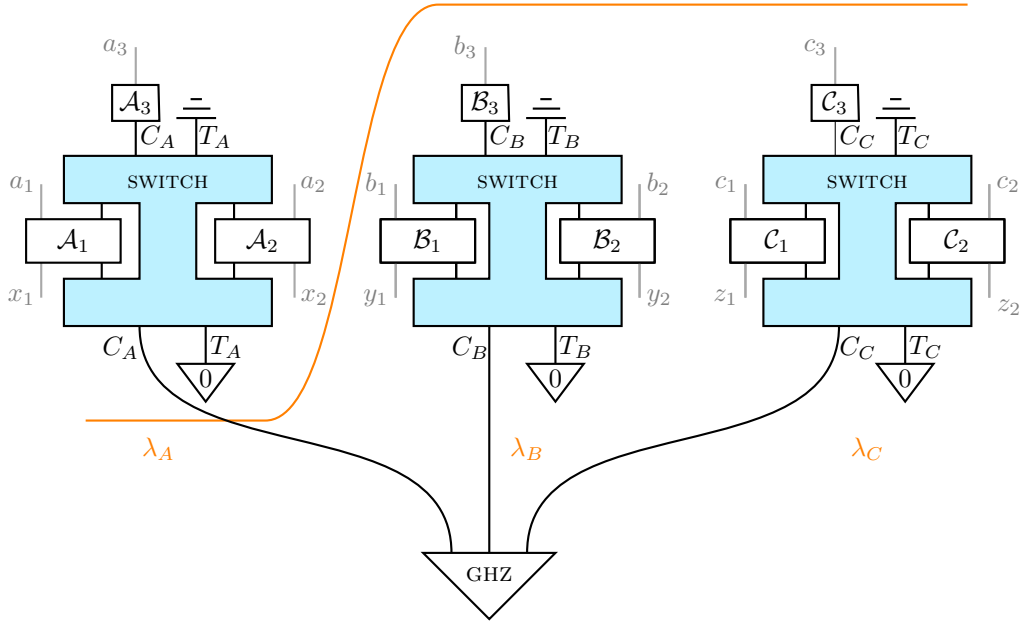

Figure 2: A GHZ-inspired quantum switch setup. The diagram is read from bottom to top; black wires are quantum systems while grey wires are classical variables. Three quantum switches (in blue) have control qubits entangled in the GHZ state. Their target systems are qubits, initially prepared in the computational basis state $|0\rangle$. Inside each switch, two parties act on the target system; their actions, here represented by classical-quantum channels, are described in the main text. The output target systems are discarded. Overall, this diagram defines the classical channel (conditional probability distribution) $Q(abc | xyz)$. The orange variables $\lambda_{A,B,C}$ denote the postulated hidden causal orders, which are assumed to take a value in the past lightcone of their respective switches. The orange line is an example of a spacelike hypersurface that can be used to argue for Equation (14b).

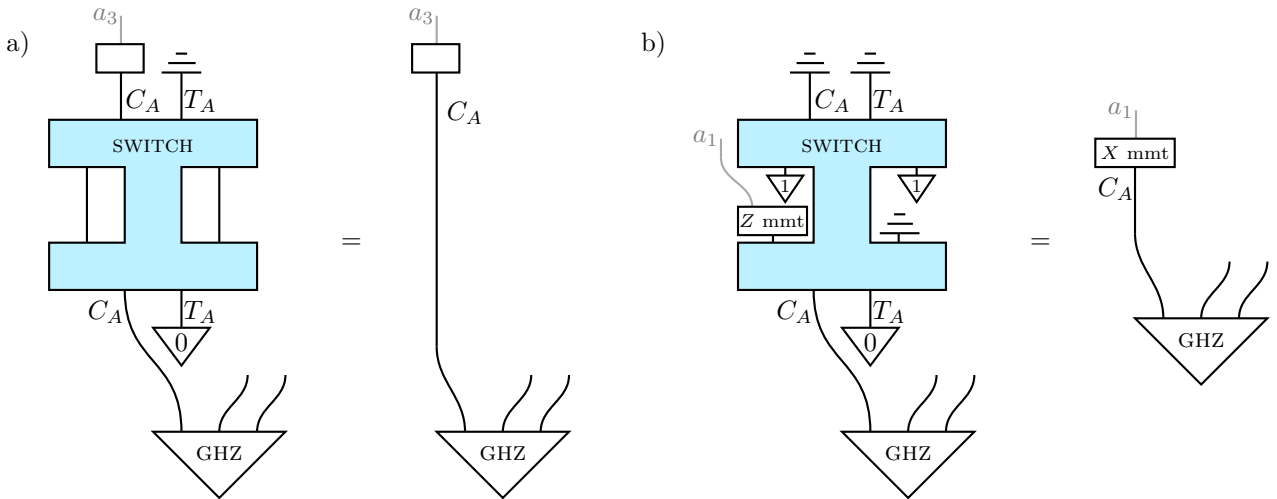

Figure 3: a) If $x_1 = x_2 = 0$, then \mathcal{A}_1 and \mathcal{A}_2 perform identity operations, so that the quantum switch itself also reduces to the identity channel. b) If $x_1 = x_2 = 1$, they both measure the target system in the computational (Z) basis and afterwards prepare the state $|1\rangle_{T_A}$. The a_1 outcome then has the same probability and postselected state as an X basis measurement of the input control qubit. (Note that the switch is controlled in the X basis.)

Assumption 1 (Definite causal order). There exist three variables $\lambda_A, \lambda_B, \lambda_C \in \{0, 1\}$ and a joint possibility distribution $q(\mathbf{abcxyz}\lambda_A\lambda_B\lambda_C)$ satisfying

$$\sum_{\lambda_A, \lambda_B, \lambda_C} q(\mathbf{abcxyz}\lambda_A\lambda_B\lambda_C) = q(\mathbf{abcxyz}), \quad (7)$$

such that $q(a_1a_2x_1x_2\lambda_A)$ is a hidden causal order model for $q(a_1a_2x_1x_2)$, $q(b_1b_2y_1y_2\lambda_B)$ for $q(b_1b_2y_1y_2)$, and $q(c_1c_2z_1z_2\lambda_C)$ for $q(c_1c_2z_1z_2)$.

In the GHZ proof, the hidden variables were (when assumed to exist) directly revealed by outcomes of measurements, allowing us to replace the output variables a, b, c in (1) by hidden variables to obtain (2). This is not necessarily the case for hidden variables determining causal orders. However, as we already noted after Observation 2, our choice of initial target state and operations performed inside the switch are such that, for $x_1 = x_2 = 1$, each value of a_1 is compatible with only one of the orderings of the operations on the target system. The following Lemma elevates this observation to the device-independent level.

Lemma 1. *Suppose that the possibility distribution $r(a_1a_2x_1x_2)$, where $a_1, a_2, x_1, x_2 \in \{0, 1\}$, satisfies*

$$r(a_1 = 1, x_2 = 0) = 0, \quad (8a)$$

$$r(a_2 = 1, x_1 = 0) = 0, \quad (8b)$$

$$\text{and } r(a_1 = a_2 = 0, x_1 = x_2 = 1) = 0, \quad (8c)$$

then any hidden causal order model $r(a_1a_2x_1x_2\lambda)$ for $r(a_1a_2x_1x_2)$ satisfies

$$x_1 = x_2 = 1 \implies_r a_1 = \lambda. \quad (9)$$

Proof. Our first claim is that

$$a_1 = 1 \implies_r \lambda = 1. \quad (10)$$

Indeed, from Equation (8a),

$$\begin{aligned} 0 &= r(a_1 = 1, x_2 = 0) \\ &\geq r(a_1 = 1, x_2 = 0, \lambda = 0) \\ &\stackrel{(6c)}{=} r(a_1 = 1, \lambda = 0)r(x_2 = 0, \lambda = 0) \\ &\stackrel{(6b)}{=} r(a_1 = 1, \lambda = 0)r(x_2 = 0)r(\lambda = 0) \\ &\stackrel{(5)}{=} r(a_1 = 1, \lambda = 0)r(\lambda = 0) \\ &= r(a_1 = 1, \lambda = 0). \end{aligned} \quad (11)$$

Moreover, we have

$$x_1 = x_2 = 1, a_1 = 0 \implies_r a_2 = 1 \implies_r \lambda = 0; \quad (12)$$

here the first implication is Equation (8c), while the second follows from an argument analogous to that for (10) but using (8b). (10) and (12) together imply the result. \square

The marginals $q(a_1a_2x_1x_2), q(b_1b_2y_1y_2)$ and $q(c_1c_2z_1z_2)$ for our three switches satisfy the conditions of Lemma 1. Therefore we can, under Assumption 1, replace some of the observed variables in (4) by hidden variables:

$$\begin{aligned} \mathbf{x} = \mathbf{1}, \mathbf{y} = \mathbf{1}, \mathbf{z} = \mathbf{1} &\implies_q \lambda_A \oplus \lambda_B \oplus \lambda_C = 0; \\ \mathbf{x} = \mathbf{1}, \mathbf{y} = \mathbf{0}, \mathbf{z} = \mathbf{0} &\implies_q \lambda_A \oplus b_3 \oplus c_3 = 1; \\ \mathbf{x} = \mathbf{0}, \mathbf{y} = \mathbf{1}, \mathbf{z} = \mathbf{0} &\implies_q a_3 \oplus \lambda_B \oplus c_3 = 1; \\ \mathbf{x} = \mathbf{0}, \mathbf{y} = \mathbf{0}, \mathbf{z} = \mathbf{1} &\implies_q a_3 \oplus b_3 \oplus \lambda_C = 1. \end{aligned} \quad (13)$$

To derive a contradiction from this set of implications, we need our final assumption.

5 Relativistic causality

Recall that the three switches are implemented at spacelike separation. Moreover, the hidden variables $\lambda_{A,B,C}$ determine the causal order between the parties in their respective switch and must therefore take values in the causal past of those parties. With this in mind, the following conditions are motivated by the principle of relativistic causality, which requires the causal order on the variables to be compatible with the provided lightcone structure—meaning in particular that freely chosen inputs cannot influence the possibility of events outside their future lightcone.

Assumption 2 (Relativistic causality). The possibility distribution $q(\mathbf{abcxyz}\lambda_A\lambda_B\lambda_C)$ of Assumption 1 satisfies

$$\lambda_A\lambda_B\lambda_C \perp\!\!\!\perp_q \mathbf{xyz}; \quad (14a)$$

$$\lambda_A b_3 c_3 \perp\!\!\!\perp_q \mathbf{x} \mid \mathbf{yz}; \quad (14b)$$

$$a_3 \lambda_B c_3 \perp\!\!\!\perp_q \mathbf{y} \mid \mathbf{xz}; \quad (14c)$$

$$a_3 b_3 \lambda_C \perp\!\!\!\perp_q \mathbf{z} \mid \mathbf{xy}. \quad (14d)$$

(Equation (14b), for instance, is motivated by the existence of the spacelike hypersurface depicted in orange in Figure 2.) These four conditions can be directly applied to the correlations in (13) to yield the four equations

$$\begin{aligned} \mathbf{x} = \mathbf{0}, \mathbf{y} = \mathbf{0}, \mathbf{z} = \mathbf{0} &\implies_q \lambda_A \oplus \lambda_B \oplus \lambda_C = 0 \\ \mathbf{x} = \mathbf{0}, \mathbf{y} = \mathbf{0}, \mathbf{z} = \mathbf{0} &\implies_q \lambda_A \oplus b_3 \oplus c_3 = 1 \\ \mathbf{x} = \mathbf{0}, \mathbf{y} = \mathbf{0}, \mathbf{z} = \mathbf{0} &\implies_q a_3 \oplus \lambda_B \oplus c_3 = 1 \\ \mathbf{x} = \mathbf{0}, \mathbf{y} = \mathbf{0}, \mathbf{z} = \mathbf{0} &\implies_q a_3 \oplus b_3 \oplus \lambda_C = 1 \quad \oplus \\ \hline \mathbf{x} = \mathbf{0}, \mathbf{y} = \mathbf{0}, \mathbf{z} = \mathbf{0} &\implies_q 0 = 1. \end{aligned} \quad (15)$$

Together with the fact that the combination $\mathbf{x} = \mathbf{y} = \mathbf{z} = \mathbf{0}$ is possible (by Eq. (5)), this yields our desired contradiction. Summarising, we have proven the following.

Theorem 1. *No possibility distribution $q(\mathbf{abcxyz})$ that satisfies Equations (4), (5), (8) and similar conditions for B and C can also satisfy the conjunction of Assumptions 1 and 2. In particular, the distribution $q(\mathbf{abcxyz})$ arising in the quantum switch scenario depicted in Figure 2 is incompatible with these assumptions.*

6 Back to probabilities: a causal Mermin inequality

Although quantum theory makes predictions about the (im)possibility of events in ideal measurement scenarios, experimental data are inevitably subject to uncertainties and are thus bound to be probab-

ilistic. Impossibilities like those of Eqs. (4) and (8) can therefore not be verified with certainty, leaving the possibilistic argument of the preceding sections unamenable to experiment. However, when the probabilistic data approximately satisfy the required impossibilities, a refutation of (probabilistic versions of) the assumptions is still possible via the violation of the following inequality, closely analogous to Mermin's inequality [8] for Bell nonlocality. The derivation of this inequality relies on the probabilistic conditions (28) given in Appendix B, which are analogous to (but stronger than) the possibilistic conditions expressed in Equation (5) and Assumptions 1 and 2, and are likewise physically motivated by the principles of free interventions, definite causal order, and relativistic causality.

Theorem 2. *Any probability distribution $P(\mathbf{abcxyz}\lambda_A\lambda_B\lambda_C)$ that fulfills the conditions in (28) satisfies the inequality*

$$\begin{aligned} & P(a_1 \oplus b_1 \oplus c_1 = 0 \mid \mathbf{x} = \mathbf{1}, \mathbf{y} = \mathbf{1}, \mathbf{z} = \mathbf{1}) + P(a_1 \oplus b_3 \oplus c_3 = 1 \mid \mathbf{x} = \mathbf{1}, \mathbf{y} = \mathbf{0}, \mathbf{z} = \mathbf{0}) \\ & + P(a_3 \oplus b_1 \oplus c_3 = 1 \mid \mathbf{x} = \mathbf{0}, \mathbf{y} = \mathbf{1}, \mathbf{z} = \mathbf{0}) + P(a_3 \oplus b_3 \oplus c_1 = 1 \mid \mathbf{x} = \mathbf{0}, \mathbf{y} = \mathbf{0}, \mathbf{z} = \mathbf{1}) \\ & - 2[P(a_1 = 1 \mid x_1x_2 = 10) + P(a_2 = 1 \mid x_1x_2 = 01) + P(a_1a_2 = 00 \mid x_1x_2 = 11) \\ & + P(b_1 = 1 \mid y_1y_2 = 10) + P(b_2 = 1 \mid y_1y_2 = 01) + P(b_1b_2 = 00 \mid y_1y_2 = 11) \\ & + P(c_1 = 1 \mid z_1z_2 = 10) + P(c_2 = 1 \mid z_1z_2 = 01) + P(c_1c_2 = 00 \mid z_1z_2 = 11)] \leq 3. \end{aligned} \quad (16)$$

Proof. See Appendix B. \square

A violation of this inequality to the algebraic bound of 4 requires precisely the possibilistic properties expressed in Eqs. (4) and (8), and is therefore attained by precisely those probabilistic data that also admit a possibilistic derivation of a contradiction with the conjunction of (5) and Assumptions 1 and 2 as in Sections 3–5—including the data Q predicted for the quantum switch scenario of Figure 2.

It is worth noting that, as Mermin did with his three-party GHZ scenario [8], the three-switch scenario considered here can be suitably generalised to one with $N > 3$ spacelike-separated switches. Definite causal order and relativistic causality then imply an inequality with bound $2^{\lfloor (3N-4)/2 \rfloor}$, which is violated by the switch scenario to the algebraic maximum of 2^{2N-3} . The proportional violation of the inequality thus grows exponentially with N .

7 Discussion

When it was shown in [2, 3] that the quantum switch exhibits indefinite causal order that can be device-independently tested, this meant that it predicts probabilities that cannot be recovered from a joint

probability distribution with a variable that constrains the causal order on *every* run of the experiment (in such a way that the order is always in accordance with relativity theory). Here, we have strengthened that result in two ways.

First, the argument in Sections 3–5 relies only on the calculus of possibilities, rather than probabilities, so it eliminates the assumption that probability theory is applicable on the hidden variable level. This assumption is nontrivial: even if the variables $\lambda_{A,B,C}$ are postulated to take values on every run of the experiment, their frequencies might not converge to probabilities satisfying the probability axioms. And while there are empirical grounds for assuming such convergence in the case of observable quantities, these do not necessarily apply to the causal order variables, as those might be unobservable in principle. In addition, the possibilistic independence assumptions involved in our argument of Sections 3–5 are much weaker than the probabilistic ones required in [2, 3], with relativistic causality conditions like (14) merely requiring that a choice of input cannot influence the *possibility*, rather than probability, of events that are spacelike-separated or lie to its past.

The maximal violation of the causal Mermin inequality (16), meanwhile, strengthens the results

of [2, 3] by showing that the quantum switch (or any other, say experimental, data that reach the algebraic maximum) is not even compatible with a (probabilistic) hidden variable model that specifies a causal order *sometimes*: any nonzero fraction of runs in which all operations are causally ordered and no superluminal influences occur leads to a value strictly below the algebraic bound.¹ In this sense the device-independent indefinite causal order in the quantum switch can be said to be maximal. It is shown in Appendix C that this result can in fact also be achieved with a single quantum switch, by using the idea of chained CHSH inequalities [11] and taking an appropriate limit.

Our proofs are much like those of Bell nonlocality by GHZ and Mermin, except that the existence of hidden variables predetermining measurement outcomes is derived from the definite causal order assumption together with properties of the data, rather than directly assumed or concluded from an EPR argument. This connection between Bell nonlocality and indefinite causal order, initially discovered in [2] in the context of a CHSH inequality, thus extends to possibilistic arguments as well. In light of this connection, this work and [2] can be compared to recent works on extended Wigner’s friend scenarios (see for instance Refs. [12–14]), in which not a definite causal order, but the observation of an agent is what predetermines a measurement outcome.² It will be worth investigating what other device-independent tests can be devised using this method, going beyond causal order and Wigner’s friend scenarios.

Another important direction for future work is to understand the physical implications of experimental violations of the inequalities presented here and in [2]. The notion of causal order, and whether it is definite or not, naturally depends on what is being ordered, i.e. on what are taken as the relata of the causal relations. In the device-independent treatment, it is customary to assume that each relatum covers both the choosing of an input and the generation of an output. This is the approach taken here and in [2, 3]. This tradition goes back to Bell’s theorem, in which such input-output pairs can be confined to a small spacetime region. Current implementations of the quantum switch however necessitate that the inputs

¹In the terminology of [3], this means that the data have a causally separable fraction of 0% over the relevant spaces of input histories.

²Our notion of relativistic causality is analogous to what is called Locality or Local Agency in [12, 13], and to what is known as parameter independence (and measurement independence) in the context of Bell’s theorem [15]. It is strictly weaker than the kind of locality already ruled out by Bell [4], GHZ [7] and Mermin [6]. On its own it is consistent with quantum physics; only in the presence of another assumption, like definite causal order (Theorems 1 and 2 and [2]), absoluteness of an agent’s observation [12, 13], determinism (Section 2 and [4, 5]), or alternatively, outcome independence [8, 15], can contradictions be derived.

of the operations inside the switch are chosen early, and the outcomes are only measured after execution of the switch [16, 17]. Consequently, (classical) relativity theory does not rule out two-way communication between the regions occupied by the input-output pairs. Is indefinite causal order with respect to these relata then still an interesting physical phenomenon, or is another choice of relata more natural? Answering these questions might require a more in-depth analysis which investigates whether such two-way communication is indeed facilitated by the used experimental setups.

Acknowledgements

We would like to thank Jonathan Barrett, Giulio Chiribella, Marc-Olivier Renou and Nicola Pinzani for insightful discussions. This research was funded in part by the Engineering and Physical Sciences Research Council (EPSRC), and was supported by the John Templeton Foundation through the ID# 62312 grant, as part of the ‘The Quantum Information Structure of Spacetime’ Project (QISS). The opinions expressed in this publication are those of the authors and do not necessarily reflect the views of the John Templeton Foundation. For the purpose of Open Access, the authors have applied a CC BY public copyright licence to any Author Accepted Manuscript (AAM) version arising from this submission.

References

- [1] Giulio Chiribella, Giacomo Mauro D’Ariano, Paolo Perinotti, and Benoit Valiron. “Quantum computations without definite causal structure”. *Physical Review A* **88**, 022318 (2013). [arxiv:0912.0195](#).
- [2] Tein van der Lugt, Jonathan Barrett, and Giulio Chiribella. “Device-independent certification of indefinite causal order in the quantum switch”. *Nature Communications* **14**, 5811 (2023). [arxiv:2208.00719](#).
- [3] Stefano Gogioso and Nicola Pinzani. “The Geometry of Causality” (2023). [arxiv:2303.09017](#).
- [4] John Stewart Bell. “On the Einstein Podolsky Rosen paradox”. *Physics* **1**, 195–200 (1964).
- [5] Daniel M. Greenberger, Michael A. Horne, and Anton Zeilinger. “Going Beyond Bell’s Theorem”. In Menas Kafatos, editor, *Bell’s Theorem, Quantum Theory and Conceptions of the Universe*. Pages 69–72. Springer Netherlands, Dordrecht (1989).
- [6] N. David Mermin. “Quantum mysteries revisited”. *American Journal of Physics* **58**, 731–734 (1990).
- [7] Daniel M. Greenberger, Michael A. Horne, Abner Shimony, and Anton Zeilinger. “Bell’s the-

- orem without inequalities”. *American Journal of Physics* **58**, 1131–1143 (1990).
- [8] N. David Mermin. “Extreme quantum entanglement in a superposition of macroscopically distinct states”. *Physical Review Letters* **65**, 1838–1840 (1990).
- [9] A. Einstein, B. Podolsky, and N. Rosen. “Can Quantum-Mechanical Description of Physical Reality Be Considered Complete?”. *Physical Review* **47**, 777–780 (1935).
- [10] G. Chiribella, G. M. D’Ariano, and P. Perinotti. “Transforming quantum operations: Quantum supermaps”. *EPL (Europhysics Letters)* **83**, 30004 (2008). [arxiv:0804.0180](#).
- [11] Samuel L Braunstein and Carlton M. Caves. “Wringing Out Better Bell inequalities”. *Annals of Physics* **202**, 22–56 (1990).
- [12] Kok Wei Bong, Aníbal Utreras-Alarcón, Farzad Ghafari, Yeong Cherng Liang, Nora Tischler, Eric G. Cavalcanti, Geoff J. Pryde, and Howard M. Wiseman. “A strong no-go theorem on the Wigner’s friend paradox”. *Nature Physics* **16**, 1199–1205 (2020). [arxiv:1907.05607](#).
- [13] Marwan Haddara and Eric G. Cavalcanti. “A possibilistic no-go theorem on the Wigner’s friend paradox”. *New Journal of Physics* **25**, 093028 (2023). [arxiv:2205.12223](#).
- [14] Nick Ormrod, V. Vilasini, and Jonathan Barrett. “Which theories have a measurement problem?” (2023). [arxiv:2303.03353](#).
- [15] Abner Shimony. “Events and processes in the quantum world”. In Roger Penrose and Christopher J. Isham, editors, *Quantum Concepts in Space and Time*. Oxford University Press (1986).
- [16] Giulia Rubino, Lee A. Rozema, Adrien Feix, Mateus Araújo, Jonas M. Zeuner, Lorenzo M. Procopio, Časlav Brukner, and Philip Walther. “Experimental verification of an indefinite causal order”. *Science Advances* **3**, e1602589 (2017). [arxiv:1608.01683](#).
- [17] Huan Cao, Jessica Bavaresco, Ning-Ning Wang, Lee A. Rozema, Chao Zhang, Yun-Feng Huang, Bi-Heng Liu, Chuan-Feng Li, Guang-Can Guo, and Philip Walther. “Semi-device-independent certification of indefinite causal order in a photonic quantum switch”. *Optica* **10**, 561 (2023). [arxiv:2202.05346](#).
- [18] Bob Coecke and Aleks Kissinger. “Picturing Quantum Processes: A First Course in Quantum Theory and Diagrammatic Reasoning”. *Cambridge University Press*. (2017). 1 edition.
- [19] John F. Clauser, Michael A. Horne, Abner Shimony, and Richard A. Holt. “Proposed Experiment to Test Local Hidden-Variable Theories”. *Physical Review Letters* **23**, 880–884 (1969).
- [20] Jonathan Barrett, Adrian Kent, and Stefano Pironio. “Maximally Nonlocal and Monogamous Quantum Correlations”. *Physical Review Letters* **97**, 170409 (2006). [arxiv:quant-ph/0605182](#).

A The quantum switch correlations and formalisation of Observations 1 and 2

Here we describe in more detail the outcome probabilities (and thus possibilities) arising in the three-switch scenario described in the main text. We then state and prove formal versions of Observations 1 and 2.

The interventions of each of the nine agents $\mathcal{A}_{1,2,3}, \mathcal{B}_{1,2,3}, \mathcal{C}_{1,2,3}$ can, for each value of their classical input variable, be described by a quantum instrument, i.e. a quantum operation with a classical outcome. A quantum instrument, with input and output systems described by Hilbert spaces \mathcal{H} and \mathcal{K} and with finite classical outcome set E , is a collection of completely positive (CP) maps $\{\mathcal{E}^e : \mathcal{B}(\mathcal{H}) \rightarrow \mathcal{B}(\mathcal{K})\}_{e \in E}$ that sum to a trace-preserving map $\sum_{e \in E} \mathcal{E}^e$. (Here $\mathcal{B}(\mathcal{H})$ and $\mathcal{B}(\mathcal{K})$ are the spaces of bounded linear operators on \mathcal{H} and \mathcal{K} .) Each map \mathcal{E}^e represents the quantum operation that ends up being performed in case outcome e is observed.

For $i = 1, 2$, the instrument performed by \mathcal{A}_i on the target system T_A for a fixed value of x_i , described intuitively in the main text, is defined by the CP maps $\mathcal{A}_i^{a_i|x_i} : \mathcal{B}(\mathcal{H}_{T_A}) \rightarrow \mathcal{B}(\mathcal{H}_{T_A})$ given by

$$\mathcal{A}_i^{a_i|x_i=0} = \delta_{a_i=0} \cdot \text{id}_{T_A} \quad (17a)$$

$$\text{and } \mathcal{A}_i^{a_i|x_i=1}(\rho_{T_A}) = |1\rangle\langle a_i|\rho_{T_A}|a_i\rangle\langle 1|, \quad (17b)$$

where id_{T_A} is the identity operation on $\mathcal{B}(\mathcal{H}_{T_A})$ and $\delta_{a_i=0}$ is 1 if $a_i = 0$ and 0 otherwise. \mathcal{A}_3 performs a projective measurement in the Y basis, described by CP maps $\mathcal{A}_3^{a_3} : \mathcal{B}(\mathcal{H}_{C_A}) \rightarrow \mathcal{B}(\mathbb{C})$ with trivial output system:

$$\mathcal{A}_3^{a_3=0}(\rho_{C_A}) = \langle +i|\rho_{C_A}|+i\rangle; \quad \mathcal{A}_3^{a_3=1}(\rho_{C_A}) = \langle -i|\rho_{C_A}|-i\rangle. \quad (18)$$

Together, when situated in one wing of the quantum switch setup considered in the main text, these instruments define the ‘joint’ instrument $\{\mathcal{A}^{\mathbf{a}|x} : \mathcal{B}(\mathcal{H}_{C_A}) \rightarrow \mathcal{B}(\mathcal{H}_{C_A})\}_{\mathbf{a}}$, with

$$\mathcal{A}^{\mathbf{a}|x}(\rho_{C_A}) := \left((\mathcal{A}_3^{a_3} \otimes \text{Tr}_{T_A}) \circ \text{SWITCH}(\mathcal{A}_1^{a_1|x_1}, \mathcal{A}_2^{a_2|x_2}) \right) (\rho_{C_A} \otimes |0\rangle\langle 0|_{T_A}). \quad (19)$$

The joint instruments $\mathcal{B}^{\mathbf{b}|y}$ and $\mathcal{C}^{\mathbf{c}|z}$ are defined similarly. The joint probabilities of the outcomes $\mathbf{a}, \mathbf{b}, \mathbf{c}$ given inputs $\mathbf{x}, \mathbf{y}, \mathbf{z}$ are then given by the distribution

$$Q(\mathbf{abc} | \mathbf{xyz}) := \left(\mathcal{A}^{\mathbf{a}|x} \otimes \mathcal{B}^{\mathbf{b}|y} \otimes \mathcal{C}^{\mathbf{c}|z} \right) (|\text{GHZ}\rangle\langle \text{GHZ}|_{C_A C_B C_C}), \quad (20)$$

which is defined diagrammatically [18] in Figure 2. Finally, together with a distribution over the input variables $Q(\mathbf{xyz})$, this gives a probability distribution $Q(\mathbf{abcxyz})$, which in turn leads to the possibility distribution $q(\mathbf{abcxyz})$ considered in the main text.

It is straightforward to verify that the marginals of this distribution satisfy the conditions (8) of Lemma 1. We can now also formalise and prove Observations 1 and 2 from the main text. This is done by Lemmas 2 and 3 below, respectively.

Lemma 2. *We have*

$$\mathcal{A}^{\mathbf{a}|x=0}(\rho_{C_A}) = \delta_{a_1=a_2=0} \cdot \mathcal{A}_3^{a_3}(\rho_{C_A}). \quad (21)$$

Proof. This follows from the fact that $\text{SWITCH}(\text{id}_{T_A}, \text{id}_{T_A}) = \text{id}_{C_A T_A}$, which is evident from the definition of the quantum switch in Eq. (3). \square

Lemma 3. *We have*

$$\sum_{a_2 a_3} \mathcal{A}^{\mathbf{a}|x=1}(\rho_{C_A}) = \begin{cases} \langle +|\rho_{C_A}|+ \rangle & \text{if } a_1 = 0; \\ \langle -|\rho_{C_A}|- \rangle & \text{if } a_1 = 1. \end{cases} \quad (22)$$

Proof. We prove the fact for pure states $\rho_{C_A} = |\psi\rangle\langle \psi|_{C_A}$; by linearity this implies the result for mixed states too. From the definition of the quantum switch (3) and the quantum instruments (17b, 19), we have

$$\mathcal{A}^{\mathbf{a}|x=1}(|\psi\rangle\langle \psi|_{C_A}) = \left\| \langle (-1)^{a_3} i \left(|+\rangle\langle +|_{C_A} \otimes |1\rangle\langle a_2|1\rangle\langle a_1|_{T_A} + |-\rangle\langle -|_{C_A} \otimes |1\rangle\langle a_1|1\rangle\langle a_2|_{T_A} \right) |\psi\rangle_{C_A} |0\rangle_{T_A} \right\|^2. \quad (23)$$

If $a_1 = 0$ then the second term (in which \mathcal{A}_1 is after \mathcal{A}_2) vanishes, giving

$$\mathcal{A}^{a_1 x=1}(|\psi\rangle\langle\psi|_{C_A}) = |\langle(-1)^{a_3}i|+\rangle_{C_A} \langle+|\psi\rangle_{C_A} \cdot \delta_{a_2=1}|^2 \quad (24)$$

so that

$$\sum_{a_2 a_3} \mathcal{A}^{a_1 x=1}(|\psi\rangle\langle\psi|_{C_A}) = |\langle+|\psi\rangle|^2. \quad (25)$$

The case for $a_1 = 1$ is similar. \square

Together with the known GHZ correlations (1), these facts imply the correlations in (4), used in our possibilistic argument, as well as the fact that the quantum switch setup violates, with the choice of instruments described here, the causal Mermin inequality (16) to the algebraic bound of 4.

B Proof of Theorem 2

In the below, probabilistic conditional independence will be denoted as

$$a \perp\!\!\!\perp_P b \mid c \quad :\iff \quad \forall a, b, c : P(ab|c) = P(a|c)P(b|c) \quad (26)$$

$$\text{and } a \perp\!\!\!\perp_P b \mid c = i \quad :\iff \quad \forall a, b : P(ab|c = i) = P(a|c = i)P(b|c = i) \quad (27)$$

$a \perp\!\!\!\perp_P b$ denotes unconditional independence $\forall a, b : P(ab) = P(a)P(b)$. The following is a restatement of Theorem 2.

Theorem. *Let $P(a_1 a_2 a_3 b_1 b_2 b_3 c_1 c_2 c_3 x_1 x_2 y_1 y_2 z_1 z_2 \lambda_A \lambda_B \lambda_C) =: P(\mathbf{abcxyz} \lambda_A \lambda_B \lambda_C)$ be a probability distribution on variables taking values in $\{0, 1\}$ that satisfies the following conditions, physically motivated as in the main text by the assumptions of free interventions, definite causal order, and relativistic causality³.*

$$\forall \mathbf{xyz} : P(\mathbf{xyz}) > 0; \quad (28a)$$

$$a_1 \perp\!\!\!\perp_P x_2 \mid \lambda_A = 0; \quad a_2 \perp\!\!\!\perp_P x_1 \mid \lambda_A = 1; \quad (28b)$$

$$b_1 \perp\!\!\!\perp_P y_2 \mid \lambda_B = 0; \quad b_2 \perp\!\!\!\perp_P y_1 \mid \lambda_B = 1; \quad (28c)$$

$$c_1 \perp\!\!\!\perp_P z_2 \mid \lambda_C = 0; \quad c_2 \perp\!\!\!\perp_P z_1 \mid \lambda_C = 1; \quad (28d)$$

$$\lambda_A \lambda_B \lambda_C \perp\!\!\!\perp_P \mathbf{xyz}; \quad \lambda_A b_3 c_3 \perp\!\!\!\perp_P \mathbf{x} \mid \mathbf{yz}; \quad a_3 \lambda_B c_3 \perp\!\!\!\perp_P \mathbf{y} \mid \mathbf{xz}; \quad a_3 b_3 \lambda_C \perp\!\!\!\perp_P \mathbf{z} \mid \mathbf{xy}; \quad (28e)$$

$$a_1 a_2 \lambda_A \perp\!\!\!\perp_P \mathbf{yz} \mid \mathbf{x}; \quad b_1 b_2 \lambda_B \perp\!\!\!\perp_P \mathbf{xz} \mid \mathbf{y}; \quad c_1 c_2 \lambda_C \perp\!\!\!\perp_P \mathbf{xy} \mid \mathbf{z}. \quad (28f)$$

Then P satisfies the inequality

$$\begin{aligned} & P(a_1 \oplus b_1 \oplus c_1 = 0 \mid \mathbf{x} = \mathbf{1}, \mathbf{y} = \mathbf{1}, \mathbf{z} = \mathbf{1}) + P(a_1 \oplus b_3 \oplus c_3 = 1 \mid \mathbf{x} = \mathbf{1}, \mathbf{y} = \mathbf{0}, \mathbf{z} = \mathbf{0}) \\ & + P(a_3 \oplus b_1 \oplus c_3 = 1 \mid \mathbf{x} = \mathbf{0}, \mathbf{y} = \mathbf{1}, \mathbf{z} = \mathbf{0}) + P(a_3 \oplus b_3 \oplus c_1 = 1 \mid \mathbf{x} = \mathbf{0}, \mathbf{y} = \mathbf{0}, \mathbf{z} = \mathbf{1}) \\ & - 2[P(a_1 = 1 \mid x_1 x_2 = 10) + P(a_2 = 1 \mid x_1 x_2 = 01) + P(a_1 a_2 = 00 \mid x_1 x_2 = 11) \\ & + P(b_1 = 1 \mid y_1 y_2 = 10) + P(b_2 = 1 \mid y_1 y_2 = 01) + P(b_1 b_2 = 00 \mid y_1 y_2 = 11) \\ & + P(c_1 = 1 \mid z_1 z_2 = 10) + P(c_2 = 1 \mid z_1 z_2 = 01) + P(c_1 c_2 = 00 \mid z_1 z_2 = 11)] \leq 3. \end{aligned} \quad (29)$$

Proof. The proof consists of two parts: we will first see that definite causal order (28b)–(28d) implies some amount of determinism, quantified by the last three lines of the inequality, and then how that determinism, together with relativistic causality (28e)–(28f), provides a Mermin-like bound on the first two lines of the inequality. (The first part parallels our going from (4) to (13) in the main text, while the second parallels the transition to (15) by relativistic causality.)

Denote the final three lines in the inequality by α, β and γ :

$$\alpha := P(a_1 = 1 \mid x_1 x_2 = 10) + P(a_2 = 1 \mid x_1 x_2 = 01) + P(a_1 a_2 = 00 \mid x_1 x_2 = 11); \quad (30a)$$

$$\beta := P(b_1 = 1 \mid y_1 y_2 = 10) + P(b_2 = 1 \mid y_1 y_2 = 01) + P(b_1 b_2 = 00 \mid y_1 y_2 = 11); \quad (30b)$$

$$\gamma := P(c_1 = 1 \mid z_1 z_2 = 10) + P(c_2 = 1 \mid z_1 z_2 = 01) + P(c_1 c_2 = 00 \mid z_1 z_2 = 11). \quad (30c)$$

³Note that unlike the other conditions in 28, condition (28f) does not have a counterpart in the main text. In brief, that is because it is not needed when assuming the perfect theoretical predictions of the quantum switch data, whilst in this appendix we wish to accommodate for noise or data that otherwise deviate from those of the quantum switch. The justification for (28f), just like (28e), is the principle of relativistic causality.

(The probabilities are independent of the omitted input variables by (28f).) The following mirrors Lemma 1 in the main text, but is probabilistic and robust to noise in the values of α, β , and γ .

Claim. *We have*

$$P(a_1 = \lambda_A \mid \mathbf{x} = \mathbf{1}) \geq 1 - \alpha; \quad (31a)$$

$$P(b_1 = \lambda_B \mid \mathbf{y} = \mathbf{1}) \geq 1 - \beta; \quad (31b)$$

$$P(c_1 = \lambda_C \mid \mathbf{z} = \mathbf{1}) \geq 1 - \gamma. \quad (31c)$$

Proof. For $i \in \{0, 1\}$, define the probability distributions $P^i(a_1 a_2 \lambda_A \mid x_1 x_2) := \delta_{\lambda_A=i} P(a_1 a_2 \mid x_1 x_2, \lambda_A = i)$. By (28b), we have $a_1 \perp\!\!\!\perp_{P^0} x_2$ and $a_2 \perp\!\!\!\perp_{P^1} x_1$, and so

$$P^0(a_1 = 1 \mid 11) = P^0(a_1 = 1 \mid 10) \leq \alpha; \quad (32)$$

$$\begin{aligned} P^1(a_1 = 0 \mid 11) &= P^1(a_1 = 0, a_2 = 0 \mid 11) + P^1(a_1 = 0, a_2 = 1 \mid 11) \\ &\leq P^1(a_1 = 0, a_2 = 0 \mid 11) + P^1(a_2 = 1 \mid 11) \\ &= P^1(a_1 = 0, a_2 = 0 \mid 11) + P^1(a_2 = 1 \mid 01) \leq \alpha. \end{aligned} \quad (33)$$

(Here the conditioned-upon variables are always x_1 and x_2 .) In other words, $P^i(a_1 \neq \lambda \mid 11) \leq \alpha$ for both $i = 0, 1$. But $P = P(\lambda = 0)P^0 + P(\lambda = 1)P^1$, so this inequality also holds for P . This implies (31a); (31b) and (31c) follow similarly. \square

Thus, if $\alpha = 0$, as is the case for the theoretical quantum switch data discussed in the main text, then we could replace terms like $P(a_1 \oplus b_1 \oplus c_1 = 0 \mid \mathbf{x} = \mathbf{y} = \mathbf{z} = \mathbf{1})$ in inequality (29) with terms like $P(\lambda_A \oplus \lambda_B \oplus \lambda_C = 0 \mid \mathbf{x} = \mathbf{y} = \mathbf{z} = \mathbf{1})$ and derive Mermin's inequality directly. To generalise this to other values of α (thereby making the result robust to noise), we use the following fact about probabilities.

Lemma 4. *For a probability distribution P over a set Ω and events $A_1, A_2, \dots, A_n \subseteq \Omega$, we have*

$$P(A_1) + P(A_2) + \dots + P(A_n) \leq P(A_1, A_2, \dots, A_n) + n - 1. \quad (34)$$

Proof. This follows from $P(A_1, A_2) = P(A_1) + P(A_2) - P(A_1 \vee A_2) \geq P(A_1) + P(A_2) - 1$ for $n = 2$ and induction. \square

From this we get, for instance,

$$\begin{aligned} &P(a_1 \oplus b_3 \oplus c_3 = 1 \mid \mathbf{100}) + P(a_1 = \lambda_A \mid \mathbf{100}) \\ &\leq P(a_1 \oplus b_3 \oplus c_3 = 1, a_1 = \lambda_A \mid \mathbf{100}) + 1 \\ &\leq P(\lambda_A \oplus b_3 \oplus c_3 = 1 \mid \mathbf{100}) + 1 \\ &= P(\lambda_A \oplus b_3 \oplus c_3 = 1 \mid \mathbf{000}) + 1, \end{aligned} \quad (35)$$

where in the last equation we have used the relativistic causality condition (28e). (Here we have suppressed the labels of the conditioned-upon variables, which are \mathbf{x}, \mathbf{y} , and \mathbf{z} , respectively.) Note that by condition (28f) and the Claim above,

$$P(a_1 = \lambda_A \mid \mathbf{100}) = P(a_1 = \lambda_A \mid \mathbf{x} = \mathbf{1}) \geq 1 - \alpha. \quad (36)$$

This, together with (35), implies (37b) below. The other inequalities can be derived in a similar way.

$$P(a_1 \oplus b_1 \oplus c_1 = 0 \mid \mathbf{111}) - \alpha - \beta - \gamma \leq P(\lambda_A \oplus \lambda_B \oplus \lambda_C = 0 \mid \mathbf{000}) \quad (37a)$$

$$P(a_1 \oplus b_3 \oplus c_3 = 1 \mid \mathbf{100}) - \alpha \leq P(\lambda_A \oplus b_3 \oplus c_3 = 1 \mid \mathbf{000}) \quad (37b)$$

$$P(a_3 \oplus b_1 \oplus c_3 = 1 \mid \mathbf{010}) - \beta \leq P(a_3 \oplus \lambda_B \oplus c_3 = 1 \mid \mathbf{000}) \quad (37c)$$

$$P(a_3 \oplus b_3 \oplus c_1 = 1 \mid \mathbf{001}) - \gamma \leq P(a_3 \oplus b_3 \oplus \lambda_C = 1 \mid \mathbf{000}) \quad (37d)$$

The desired inequality (29) now follows by adding these equations together and noting that the sum of the right-hand sides is bounded (similarly to Mermin's inequality [8]) by 3. This last fact

follows from Lemma 4, and parallels the derivation of the logical contradiction (15) in the main text:

$$\begin{aligned}
& P(\lambda_A \oplus \lambda_B \oplus \lambda_C = 0 \mid \mathbf{000}) + P(\lambda_A \oplus b_3 \oplus c_3 = 1 \mid \mathbf{000}) \\
& + P(a_3 \oplus \lambda_B \oplus c_3 = 1 \mid \mathbf{000}) + P(a_3 \oplus b_3 \oplus \lambda_C = 1 \mid \mathbf{000}) \\
& \leq P(0 = 1 \mid \mathbf{000}) + 3 = 3.
\end{aligned} \tag{38}$$

This concludes the proof of Theorem 2. \square

C Chained inequalities

That the Mermin inequality (resp. causal Mermin inequality (16)) is violated up to the algebraic maximum (i.e. the maximum value among all valid probability distributions) implies that no fraction of the distribution allows a local deterministic hidden variable model (resp. definite causal order model satisfying relativistic causality). However, this only implies that it is never the case that all of the three switches have a causal order simultaneously. Here we show that a similar result can be derived for a single quantum switch, by using the idea of chained Bell inequalities introduced by Braunstein and Caves [11], which are violated to the algebraic maximum in the limit of a large number of measurement settings N .

We first recall Braunstein and Caves's chained inequalities as they apply to Bell nonlocality. Consider a scenario with two spacelike-separated parties \mathcal{A} and \mathcal{B} , having inputs $x, y \in \{0, 1, \dots, N-1\}$ and outputs $a, b \in \{0, 1\}$. Any choice of a pair of values for x as well as for y can be used to define a Clauser-Horne-Shimony-Holt (CHSH) expression: more precisely, for any probability distribution $R(ab|xy)$ and $\xi_0, \xi_1, \nu_0, \nu_1 \in \{0, 1, \dots, N-1\}$, define

$$\begin{aligned}
\text{CHSH}_{\xi_0, \xi_1; \nu_0, \nu_1}[R] & := R(a = b \mid x = \xi_0, y = \nu_0) \\
& + R(a = b \mid x = \xi_1, y = \nu_0) \\
& + R(a = b \mid x = \xi_1, y = \nu_1) \\
& - R(a = b \mid x = \xi_0, y = \nu_1).
\end{aligned} \tag{39}$$

Summing an appropriate set of such CHSH expressions together defines the Braunstein-Caves expression

$$\text{BC}_N[R] := \sum_{i=0}^{N-1} \text{CHSH}_{0, i; i-1, i}[R] \tag{40}$$

$$\begin{aligned}
& = \sum_{i=0}^{N-1} [R(a_3 = b \mid x_3 = i, y = i) + R(a_3 = b \mid x_3 = i+1, y = i)] \\
& + R(a_3 = b \mid x_3 = N, y = N) - R(a_3 = b \mid x_3 = 0, y = N).
\end{aligned} \tag{41}$$

The classical bound for each of the CHSH expressions is 2 [19], leading to an overall classical bound of

$$\text{BC}_N[R] \leq 2N. \tag{42}$$

The algebraic maximum of $\text{BC}_N[R]$, on the other hand, can be read off from (41) to be $2N + 1$.

A high quantum value for BC_N can be achieved by letting \mathcal{A} and \mathcal{B} measure the two parts of the Bell state $|\Phi^+\rangle$ in the measurement directions shown in Figure 4. The directions are spaced an angle $\theta = \pi/(N+1)$ apart on the Bloch sphere. All terms in the expansion (41) except the last involve a neighbouring pair of measurement directions, yielding a probability of $\cos^2 \theta/2$. In total, the quantum value is

$$\begin{aligned}
\text{BC}_N[R] & = (2N+1) \cos^2 \frac{\theta}{2} - \left(1 - \cos^2 \frac{\theta}{2}\right) \\
& = (N+1) \left(\cos \frac{\pi}{N+1} + 1 \right) - 1 \xrightarrow{N \gg 1} 2N+1,
\end{aligned} \tag{43}$$

which approaches the algebraic maximum in the limit of large N .

A crucial observation is that the classical bound of 2 for a CHSH expressions follows (under additional requirements sometimes called measurement independence and parameter independence) not only from the assumption that all measurements outcomes are predetermined, but also from the weaker requirement that only \mathcal{A} 's outcome a for one of her inputs x is predetermined. Because all CHSH expressions in (40) involve the input $x = 0$, this means that the classical bound $\text{BC}_N[R] \leq 2N$ also holds when only the $x = 0$ measurement is predetermined. This will allow us to make the translation from Bell nonlocality to indefinite causal order in the quantum switch, by using a quantum switch to simulate the $x = 0$ measurement (in the spirit of Observation 1 in the main text), while noting that the definite causal order assumption implies predetermination of that measurement (in the spirit of Lemma 1).

The relevant quantum switch scenario is depicted in Figure 5. The quantum switch is now controlled in the Z basis (rather than X , as in the main text). \mathcal{A}_1 and \mathcal{A}_2 perform the same quantum instruments as described in the main text and Appendix A. \mathcal{A}_3 and \mathcal{B} perform measurements on the output control qubit and a qubit B entangled to the input control qubit, respectively. Their inputs x_3, y take values in $\{0, 1, \dots, N\}$ and their measurement directions are identical to those in the usual chained inequality scenario just described (Figure 4). All other variables are binary, as in the main text. This setup defines a conditional probability distribution $Q(a_1 a_2 a_3 b | x_1 x_2 x_3 y)$, which in turn defines an unconditional probability distribution $Q(a_1 a_2 a_3 b x_1 x_2 x_3 y)$ by assuming uniform distribution of the inputs: $Q(x_1 x_2 x_3 y) = 1/4N^2$.

In the main text, our first step was to find a subset of the quantum switch data that exhibited GHZ-like correlations (i.e. going from (1) to (4)). Likewise, here we will need to find a subset of the data Q that behaves as R in (43) above, i.e. which violates the Braunstein-Caves inequality to the algebraic maximum in the limit of large N . To do this, note that one can consider \mathcal{A}_3 and \mathcal{B} as performing a Braunstein-Caves test on the shared entangled state $|\Phi^+\rangle$, with two differences. First of all, when $x_3 = 0$, we need to ensure that $x_1 = x_2 = 1$ and let \mathcal{A}_3 output a_1 , as that is a simulation of the computational basis measurement (Observation 2). When $x_3 \neq 0$, on the other hand, we need to ensure that $x_1 = x_2 = 0$, so that the outcome a_3 is not disturbed by the presence of the quantum switch (Observation 1). The data in Q that are relevant to the derivation and violation of Braunstein-Caves inequalities is therefore summarised in the distribution R_Q defined in (45) below.

We then get the following theorem. As in the main text, the conditions (44) are motivated by the assumptions of free interventions, definite causal order, and relativistic causality.

Theorem 3. *Let λ be a random variable with domain $\{0, 1\}$. Suppose the probability distribution $P(a_1 a_2 a_3 b x_1 x_2 x_3 y \lambda)$ satisfies*

$$\forall x_1 x_2 x_3 y : P(x_1 x_2 x_3 y) > 0; \quad (44a)$$

$$\lambda \perp\!\!\!\perp_P x_1 x_2 x_3 y; \quad (44b)$$

$$a_1 \perp\!\!\!\perp_P x_2 \mid \lambda = 0; \quad a_2 \perp\!\!\!\perp_P x_1 \mid \lambda = 1; \quad (44c)$$

$$\lambda b \perp\!\!\!\perp_P x_1 x_2 x_3 \mid y; \quad \lambda a_1 a_2 a_3 \perp\!\!\!\perp_P y \mid x_1 x_2 x_3; \quad \lambda a_1 a_2 \perp\!\!\!\perp_P x_3 y \mid x_1 x_2, \quad (44d)$$

and let

$$R_P(ab\lambda \mid x_3 y) := \begin{cases} P(a_1 = a, b, \lambda \mid x_1 = x_2 = 1, x_3, y) & \text{if } x_3 = 0; \\ P(a_3 = a, b, \lambda \mid x_1 = x_2 = 0, x_3, y) & \text{if } x_3 \neq 0 \end{cases} \quad (45)$$

and

$$\alpha[P] := P(a_1 = 1 \mid x_1 x_2 = 10) + P(a_2 = 1 \mid x_1 x_2 = 01) + P(a_1 a_2 = 00 \mid x_1 x_2 = 11). \quad (46)$$

Then P satisfies the inequality

$$\text{BC}_N[R_P] - 2N\alpha[P] \leq 2N. \quad (47)$$

The quantum value of this expression is

$$\text{BC}_N[R_Q] - 2N\alpha[Q] = (N + 1) \left(\cos \frac{\pi}{N + 1} + 1 \right) - 1. \quad (48)$$

Theorem 3 gives

$$\text{BC}_N [R_{Q^{\{0,1\}}}] - 2N \alpha [Q^{\{0,1\}}] \leq 2N. \quad (56)$$

Because the algebraic maximum of BC_N is $2N + 1$ and the inequality is linear, this implies

$$\text{BC}_N [R_Q] - 2N \alpha [Q] \leq 2N + Q(\lambda = \perp) = 2N + 1 - Q(\lambda \in \{0, 1\}). \quad (57)$$

Inserting (48) and rearranging gives the result. \square