

EXTENSIONS OF WEAK MATROIDS OVER SKEW TRACTS AND STRONG MATROIDS OVER STRINGENT SKEW HYPERFIELDS

TING SU

ABSTRACT. Matroids over skew tracts provide an algebraic framework simultaneously generalizing the notions of linear subspaces, matroids, oriented matroids, phased matroids, and some other “matroids with extra structure”. A single-element extension of a matroid \mathcal{M} over a skew tract T is a matroid $\widehat{\mathcal{M}}$ over T obtained from \mathcal{M} by adding one more element. Crapo characterized single-element extensions of ordinary matroids, and Las Vergnas characterized single-element extensions of oriented matroids, in terms of single-element extensions of their rank 2 contractions. The results of Crapo and Las Vergnas do not generalize to matroids over skew tracts, but we will show a necessary and sufficient condition on skew tracts, called *Pathetic Cancellation*, such that the result can generalize to weak matroids over skew tracts.

Stringent skew hyperfields are a special case of skew tracts which behave in many ways like skew fields. We find a characterization of single-element extensions of strong matroids over stringent skew hyperfields.

1. INTRODUCTION

A *matroid* ([CR70],[Wel76]) is a combinatorial object that abstracts the notion of linear independence in a vector configuration over an arbitrary field. An *oriented matroid* ([BLV78], [LV75]) is a combinatorial object that abstracts the notion of linear independence in a vector configuration over an ordered field. The theories of matroids and oriented matroids are major branches of combinatorics with applications in many fields of mathematics, including topology, algebra, graph theory, and geometry.

In [BB19], Baker and Bowler introduced *matroids over tracts*, which is an algebraic framework simultaneously generalizing the notion of linear subspaces, matroids, oriented matroids, phased matroids, and some other “matroids with extra structure.” Pendavingh ([Pen18]) partially extended the theory of matroids over tracts to skew hyperfields and defined weak matroids over skew hyperfields. In [Su20], Su presented a theory of *matroids over skew tracts*, which generalize both the theory of matroids over tracts and the theory of weak matroids over skew hyperfields by Pendavingh.

The *single-element extension* is an operation on matroids over skew tracts. For the construction and analysis of matroids over skew tracts it is of interest to describe the set of all single-element extensions of a given matroid over a skew tract. For instance, this is useful for proofs by induction on the size of the ground set: every rank d matroid over a skew tract T can be obtained from some rank d matroid over T on d elements by a sequence of single-element extensions. Crapo found a characterization of single-element extensions of ordinary matroids in terms of cocircuits ([Cra65]), and Las Vergnas found a characterization of single-element extensions of oriented matroids in terms of signed cocircuits ([LV78]). Most importantly, they showed that single-element extensions can be understood in terms of single-element extensions of rank 2 contractions. The results of Crapo and Las Vergnas do not generalize to matroids over skew tracts, but we show a necessary and sufficient condition on a skew tract T called *Pathetic Cancellation* such that the results can generalize to weak matroids over T .

Stringent skew hyperfields are a special case of skew tracts which behave in many ways like skew fields ([BS21]). In particular, the stringency implies the Pathetic Cancellation property. We find a similar characterization of single-element extensions of strong matroids over stringent skew hyperfields.

In the introduction, we will first talk about the characterization of single-element extensions of oriented matroids. Then, we will talk about single-element extensions of matroids over skew tracts and stringent skew hyperfields.

Key words and phrases. hyperfields, tracts, extensions, localizations, Pathetic Cancellation.

1.1. Classical results for oriented matroids. Throughout we will assume that readers have a basic knowledge of matroids and oriented matroids. As a general reference, we refer to [Oxl92, BLVS⁺99].

1.1.1. single-element extensions of oriented matroid. There is a nice characterization of single-element extension of oriented matroids in terms of cocircuits and Las Vergnas found it in [BLV78].

Let us see single-element extensions of oriented matroids by an example. The Topological Representation Theorem for oriented matroids ([FL78]) says that there is a one-to-one correspondence between (equivalence classes of) arrangements of signed pseudospheres in S^d and simple rank $d + 1$ oriented matroids.

Figure 1 represents an oriented matroid \mathcal{M} of rank 3 on the ground set $[5]$; it has five signed pseudolines ($\mathcal{S}_e : e \in [5]$) (given by solid curves) with small arrows pointing to the positive side. The signed cocircuits correspond to the 0-dimensional points: $\mathcal{C}^* = \{\pm Y_k \mid 1 \leq k \leq 8\}$, where $-Y_k(e) = -(Y_k(e))$ for all $e \in [5]$. We extended \mathcal{M} by p , with pseudocircle S_p given by a dashed curve. Then there are six more signed cocircuits for $\widetilde{\mathcal{M}}$: $\{\pm Z_1, \pm Z_2, \pm Z_3\}$. We can see that there is a unique function σ from the signed cocircuits set \mathcal{C}^* of \mathcal{M} to $\{+, -, 0\}$ such that σ signifies, for every signed cocircuit Y , whether it is supposed to lie in S_p^+ or S_p^- , or on S_p , defined by

$$\sigma(Y) = \begin{cases} + & \text{if signed cocircuit } Y \text{ lies in } S_p^+, \\ - & \text{if signed cocircuit } Y \text{ lies in } S_p^-. \\ 0 & \text{if signed cocircuit } Y \text{ lies on } S_p, \end{cases} \quad (1)$$

For instance, $\sigma(Y_1) = 0$, $\sigma(Y_2) = +$ and $\sigma(Y_4) = -$. We can determine the extension by looking at the σ value for the signed cocircuits on every pseudocircle. For instance, as $\sigma(Y_3) = +$ and $\sigma(Y_5) = -$, the pseudocircle S_p should cross the pseudocircle S_2 between Y_3 and Y_5 . This function σ is called the *localization* corresponding to the extension $\widetilde{\mathcal{M}}$.

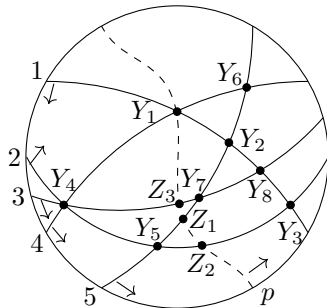

FIGURE 1. The single-element extension of the oriented matroid \mathcal{M} by p

1.1.2. Reduction of extensions to rank 2. Rank 2 oriented matroids are very easy to understand. For example, every rank 2 oriented matroid is realizable. And rank 2 contractions of an oriented matroid correspond to pseudocircles in topological representation.

In this subsection, we will describe modularity of cocircuits, which helps to reduce questions to rank 2 contractions.

Definition 1.1. [Sta12] Let L be a lattice. An element $x \in L$ is called an **atom** if $x \neq \hat{0}$ and there is no $z \in L$ with $\hat{0} < z < x$. Two atoms $x, y \in L$ form a **modular pair** if $l(L_{x \vee y}) = 2$, i.e., $x \neq y$ and there do not exist $z_1, z_2 \in L$ with $\hat{0} < z_1 < z_2 < x \vee y$.

Let E be a set and let C be a collection of pairwise incomparable nonempty subsets of E . The set $U(C) := \{\bigcup S \mid S \subseteq C\}$ forms a lattice when equipped with the partial order coming from inclusion of sets, with join corresponding to union and with the meet of X and Y defined to be the union of all sets in C contained in both X and Y . So every $X \in C$ is atomic as an element of $U(C)$. We say that $C_1, C_2 \in C$ form a **modular pair** in C if they are a modular pair in $U(C)$; that is, the height of their join in the lattice $U(C)$ is 2.

Definition 1.2. In an oriented matroid \mathcal{M} on E , two signed cocircuits $X, Y \in \mathcal{C}^*(\mathcal{M})$ form a **modular pair** in \mathcal{M} if \underline{X} and \underline{Y} form a modular pair in the lattice of unions of supports of elements of $\mathcal{C}^*(\mathcal{M})$.

In a pseudosphere arrangement in S^d , it is easy to find a modular pair. Two signed cocircuits form a modular pair if and only if the corresponding two points in S^d are on a common pseudocircle. For example, in Figure 1, the signed cocircuits Y_1 and Y_2 form a modular pair, and the signed cocircuits Y_1 and Y_5 do not form a modular pair.

Now let's consider single-element extensions of oriented matroids. We will see that an extension can be determined by the function σ we defined by Equation (1) in the last section. Recall that the function $\sigma : \mathcal{C}^* \rightarrow \{+, -, 0\}$ signifies, for every signed cocircuit Y , whether it is supposed to lie on the positive side or on the negative side of the extended pseudocircle S_p or on S_p itself. The extended oriented matroid $\widetilde{\mathcal{M}}$ is uniquely determined by σ , and we can determine all the signed cocircuits of $\widetilde{\mathcal{M}}$ by looking at the σ value for the signed cocircuits of \mathcal{M} on every pseudocircle (rank 2 situation).

For instance, let us see the pseudocircle S_5 , as in Figure 2. As Y_6, Y_2 and Y_7 are in S_p^+ , thus we can get three signed cocircuits for $\widetilde{\mathcal{M}}$: Y_6p^+, Y_2p^+ and Y_7p^+ . Similarly, as Y_5 is in S_p^- , thus we can get a signed cocircuits for $\widetilde{\mathcal{M}}$: Y_5p^- . And Y_5 and Y_7 form a modular pair in $\mathcal{C}^*(\mathcal{M})$, and they are on opposite sides of S_p . So we can get a signed cocircuits Z_1 via modular elimination between Y_5p^- and Y_7p^+ by p .

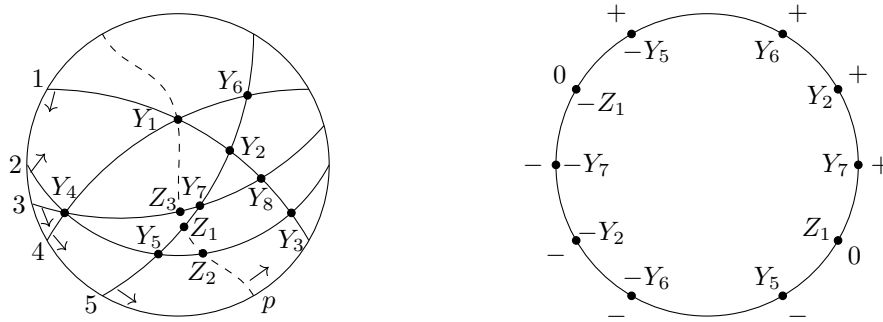

FIGURE 2. The single-element extension of \mathcal{M} by p and the pseudoline S_5

Moreover, Las Vergnas ([LV78]) proved that if a function σ determines an extension on every pseudocircle, then it determines an extension of the oriented matroid.

Theorem 1.3. ([BLVS⁺99], see also [LV78]) *Let \mathcal{M} be an oriented matroid with signed cocircuit set $\mathcal{C}^*(\mathcal{M})$ and let*

$$\sigma : \mathcal{C}^*(\mathcal{M}) \rightarrow \{+, -, 0\}$$

be a function, satisfying $\sigma(-Y) = -\sigma(Y)$ for all $Y \in \mathcal{C}^(\mathcal{M})$.*

Then the following statements are equivalent.

- (1) σ defines a single-element extension $\widetilde{\mathcal{M}}$ of \mathcal{M} .
- (2) σ defines a single-element extension of every rank 2 contraction of \mathcal{M} .
- (3) σ defines a single-element extension of every rank 2 minor of \mathcal{M} on three elements.

For the single-element extension of a matroid, there is not a nice topological picture like that for oriented matroids, but there is a similar result. We will introduce it in Section 2.5

This paper will generalize the results of Crapo and Las Vergnas to matroids over skew tracts.

1.2. New results for matroids over skew tracts and skew hyperfields.

1.2.1. *Skew hyperfields and tracts.* A skew hyperfield is an algebraic structure similar to a skew field except that its addition is multivalued (cf. [Vir10]). In particular, every skew field is a skew hyperfield. There are many interesting examples of skew hyperfields, and some are introduced as follows.

The **Krasner hyperfield** $\mathbb{K} := \{0, 1\}$ has the usual multiplication rule and hyperaddition is defined by $0 \boxplus x = \{x\}$ for $x \in \mathbb{K}$ and $1 \boxplus 1 = \{0, 1\}$.

The **sign hyperfield** $\mathbb{S} := \{0, 1, -1\}$ has the usual multiplication rule and hyperaddition is defined by $0 \boxplus x = \{x\}$, $x \boxplus x = \{x\}$ for $x \in \mathbb{S}$ and $1 \boxplus -1 = \{0, 1, -1\}$.

The **phase hyperfield** $\mathbb{P} := S^1 \cup \{0\}$ has the usual multiplication rule and hyperaddition is defined by $0 \boxplus x = \{x\}$ for $x \in \mathbb{P}$, $x \boxplus -x = \{0, x, -x\}$ and $x \boxplus y = \left\{ \frac{ax+by}{|ax+by|} \mid a, b \in \mathbb{R}_{>0} \right\}$ for $x, y \in S^1$ and $x \neq -y$, as in Figure 3.

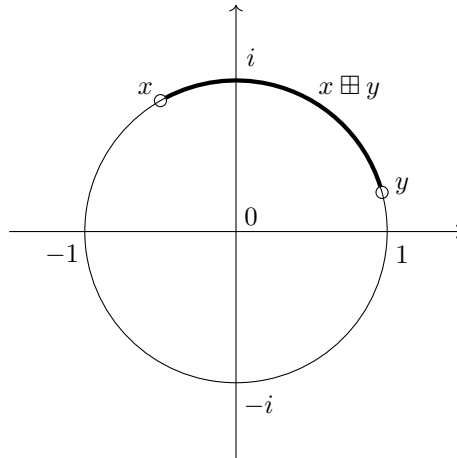

FIGURE 3

A skew hyperfield F is said to be **stringent** if, for any a, b in F , $a \boxplus b$ is a singleton whenever $a \neq -b$ ([BS21]). Skew fields, \mathbb{K} and \mathbb{S} are all stringent.

Example 1.4. The phase hyperfield \mathbb{P} does not satisfy stringency. $1 \boxplus i = \{e^{\alpha i} \mid \alpha \in (0, \pi/2)\}$.

A *hyperfield* is a skew hyperfield with commutative multiplication. Hyperfields are a special cases of still more general objects called tracts, which appear to be a natural setting for matroid theory ([BB19]). Tracts generalize fields, hyperfields in the sense of Krasner ([Kra57]), partial fields in the sense of Semple and Whittle ([SW96]), and fuzzy rings in the sense of Dress ([Dre86]).

1.2.2. *Matroids over skew tracts.* Baker and Bowler ([BB19]) introduced matroids over a tract T and called them T -matroids. An T -matroid for a field T corresponds to a linear subspace of some F^n . A \mathbb{K} -matroid is a usual matroid. An \mathbb{S} -matroid is an oriented matroid. A \mathbb{P} -matroid is a phased matroid ([AD12]).

Baker and Bowler also provided two natural notions of matroids over a tract T , *weak T -matroids* and *strong T -matroids*, which diverge for certain tracts. This is a new phenomenon because weak matroids and strong matroids are the same for fields, \mathbb{K} and \mathbb{S} . They provided both circuit axioms and Grassman-Plücker axioms for weak and strong T -matroids. The weak circuit axioms looks more like the (signed) circuit axioms for (oriented) matroids and generalize them better than the strong axioms. The strong Grassmann-Plücker axioms looks more like the chirotope axioms for oriented matroids and generalize them better than the weak axioms. Weak matroids and strong matroids coincide in rank 2.

In [Pen18], Pendavingh partially extended the theory of matroids over tracts to skew hyperfields. He provided several cryptomorphic axiom systems for weak matroids over skew hyperfields, including circuits axioms and a new axiom system in terms of quasi-Plücker coordinates.

Su ([Su20]) presented matroids over skew tracts, which generalize both matroids over tracts and weak matroids over skew hyperfields by Pendavingh ([Pen18]). Similarly, Su provided two natural notions of matroids over a skew tract T , *weak T -matroids* and *strong T -matroids*, corresponding to the two notions of matroids over tracts. Su gave several cryptomorphic axiom systems for both kinds of T -matroids.

Section 2 will give background, including definition of skew tracts, two natural notions of matroids over skew tracts and two cryptomorphic axioms systems for both two kinds of matroids over skew tracts: circuit axioms and quasi-Plücker axioms. Section 3 will define extensions and localizations, and present the quasi-Plücker coordinates and T -cocircuit set for the extended T -matroid. The main result of this paper, in Section 4 and 5, is a characterization of the single-element extensions of a weak matroid over a skew tract T if T satisfies a special property, called *Pathetic Cancellation*. This generalizes the characterization of the single-element extensions of matroids (Theorem 2.28) and the characterization of the single-element extensions of oriented matroids (Theorem 1.3).

Theorem 1.5. *Let T be a skew tract, let \mathcal{M} be a weak left (resp. right) T -matroid on a set E with T -cocircuit set $\mathcal{C}^*(\mathcal{M})$, and let*

$$\sigma : \mathcal{C}^*(\mathcal{M}) \rightarrow T$$

be a right (resp. left) T^\times -equivariant function.

Then T satisfies Pathetic Cancellation if and only if the following statements are equivalent.

- (1) σ defines a weak single-element extension of \mathcal{M} .
- (2) σ defines a weak single-element extension of every rank 2 contraction of \mathcal{M} .
- (3) σ defines a weak single-element extension of every rank 2 minor of \mathcal{M} on three elements.

Note that in this theorem, (1) \Rightarrow (2) \Rightarrow (3) is obviously true.

Bowler and Pendavingh showed that the notions of weak and strong F -matroid coincide if F is a stringent skew hyperfield in [BP19].

In Section 6, we show that the stringency implies the Pathetic Cancellation property. So a similar characterization of single-element extensions is also true for strong matroids over stringent skew hyperfields.

Theorem 1.6. *Let F be a stringent skew hyperfield, let \mathcal{M} be a strong left (resp. right) F -matroid on E with F -cocircuit set $\mathcal{C}^*(\mathcal{M})$, and let*

$$\sigma : \mathcal{C}^*(\mathcal{M}) \rightarrow F$$

be a right (resp. left) F^\times -equivariant function.

Then the following statements are equivalent.

- (1) σ defines a strong single-element extension of \mathcal{M} .
- (2) σ defines a strong single-element extension of every rank 2 contraction of \mathcal{M} .
- (3) σ defines a strong single-element extension of every rank 2 minor of \mathcal{M} on three elements.

1.3. Acknowledgment. Many thanks to my PhD advisor Laura Anderson for all help and guidance on my thesis which is the original version (commutative tracts case) of this paper and for helpful feedback and suggestions. Thanks also to Nathan Bowler for asking whether the results might hold for skew tracts and for helpful discussion and suggestions.

2. BACKGROUND

2.1. Hyperfields and tracts.

Definition 2.1. A **hyperoperation** on a set S is a map \boxplus from $S \times S$ to the collection of non-empty subsets of S .

If A, B are non-empty subsets of S , we define

$$A \boxplus B := \bigcup_{a \in A, b \in B} (a \boxplus b)$$

and we say that \boxplus is **associative** if $a \boxplus (b \boxplus c) = (a \boxplus b) \boxplus c$ for all $a, b, c \in S$.

All hyperoperations in this paper will be commutative and associative.

Definition 2.2. [BB16] A (commutative) **hypergroup** is a triple $(G, \boxplus, 0)$ where \boxplus is a commutative and associative hyperoperation on G such that:

- (1) $0 \boxplus x = \{x\}$ for all $x \in G$.
- (2) For every $x \in G$ there is a unique element of G (denoted by $-x$ and called the **hyperinverse** of x) such that $0 \in x \boxplus -x$.
- (3) $x \in y \boxplus z$ if and only if $z \in x \boxplus -y$.

A **skew hyperfield** is a tuple $(F, \odot, \boxplus, 1, 0)$ such that $0 \neq 1$:

- (1) $(F - \{0\}, \odot, 1)$ is a group.
- (2) $(F, \boxplus, 0)$ is a hypergroup.
- (3) (Absorption rule) $x \odot 0 = 0 \odot x = 0$ for all $x \in F$.
- (4) (Distributive Law) $a \odot (x \boxplus y) = (a \odot x) \boxplus (a \odot y)$ and $(x \boxplus y) \odot a = (x \odot a) \boxplus (y \odot a)$ for all $a, x, y \in F$.

A **hyperfield** is then a skew hyperfield with commutative multiplication.

If F is a skew hyperfield, then F^E has a hypergroup structure given by

$$X \boxplus Y := \{Z \mid Z(e) \in X(e) \boxplus Y(e), \forall e \in E\}.$$

F acts on F^E by componentwise multiplication. (Formally, F^E is an F -module (cf. subsection 2.18 in [BB16]).)

Example 2.3. Now we would like to present two more examples of skew hyperfields.

- (1) If F is a (skew) field, then F is a (skew) hyperfield with $a \odot b = a \cdot b$ and $a \boxplus b = \{a + b\}$, for $a, b \in F$.
- (2) Let D_6 be the dihedral group of order 6. Let $F := D_6 \cup \{0\}$ with multiplication given by $x \cdot y = 0$ if x or y is 0 and by the multiplication of D_6 otherwise. Hyperaddition is given by

$$x \boxplus y = \begin{cases} F \setminus \{0\} & \text{if } x \neq y. \\ F & \text{if } x = y. \end{cases}$$

It is easy to check that F is a skew hyperfield.

Definition 2.4. [Su20] A **skew tract** is a group G (written multiplicatively), together with an **additive relation structure** on G , which is a subset N_G of the group semiring $\mathbb{N}[G]$ satisfying:

- (1) The zero element of $\mathbb{N}[G]$ belongs to N_G .
- (2) The identity element 1 of G is not in N_G .
- (3) There is a unique element ε of G with $1 + \varepsilon \in N_G$.
- (4) N_G is closed under the natural left and right actions of G on $\mathbb{N}[G]$.

A **tract** is a skew tract with the group G abelian.

One thinks of $\mathbb{N}[G]$ as those linear combinations of elements of G which “sum to zero” (the N in $\mathbb{N}[G]$ stands for “null”).

We let $T = G \cup \{0\}$ and $T^\times = G$. We often refer to the skew tract (G, N_G) simply as T , and we often write -1 instead of ε and $-x$ instead of εx .

For a skew hyperfield F with hyperaddition \boxplus , we could define a skew tract (G, N_G) associated to this skew hyperfield by setting $G = F \setminus \{0\}$ and $N_G = \{\sum_{i=1}^k g_i \mid \forall i, g_i \in G \text{ and } 0 \in \boxplus_{i=1}^k g_i\}$.

If T is a skew tract and $X, Y \in T^E$, then we define,

$$X + Y := \{Z \mid \forall e \in E, X(e) + Y(e) - Z(e) \in N_G\},$$

T acts on T^E by componentwise multiplication.

Definition 2.5. [Su20] A **homomorphism** $f : (G, N_G) \rightarrow (H, N_H)$ of skew tracts is a group homomorphism $f : G \rightarrow H$, together with a map $f : \mathbb{N}[G] \rightarrow \mathbb{N}[H]$ satisfying $f(\sum_{i=1}^k g_i) = \sum_{i=1}^k f(g_i)$ for $g_i \in G$, such that if $\sum_{i=1}^k g_i \in N_G$ then $\sum_{i=1}^k f(g_i) \in N_H$.

Definition 2.6. [Su20] Let T be a skew tract. An **involution** of T is a homomorphism $\tau : T \rightarrow T$ such that τ^2 is the identity map. Denote the image of $x \in T$ under τ by \bar{x} .

Definition 2.7. [Su20] Let T be a skew tract endowed with an involution $x \mapsto \bar{x}$. For $X, Y \in T^E$, the **product** of X and Y is defined as

$$X \cdot Y := \sum_{e \in E} X(e) \cdot \overline{Y(e)}.$$

We say that X, Y are **orthogonal**, denoted by $X \perp Y$, if $X \cdot Y \in N_G$.

Let $\mathcal{C}, \mathcal{D} \subseteq T^E$. We say that \mathcal{C}, \mathcal{D} are **orthogonal**, denoted by $\mathcal{C} \perp \mathcal{D}$, if $X \cdot Y \in N_G$ for all $X \in \mathcal{C}$ and $Y \in \mathcal{D}$. We say that \mathcal{C}, \mathcal{D} are **k -orthogonal**, denoted by $\mathcal{C} \perp_k \mathcal{D}$, if $X \perp Y$ for all $X \in \mathcal{C}$ and $Y \in \mathcal{D}$ such that $|\underline{X} \cap \underline{Y}| \leq k$.

When T is the field \mathbb{C} of complex numbers or the phase matroid \mathbb{P} , the usual involution on T is complex conjugation. For T is \mathbb{K} or \mathbb{S} , the usual involution on T is the identity map.

2.2. Matroids over skew tracts.

Notation 2.8. Throughout E denotes a non-empty finite set. T denotes a skew tract. For a skew tract T , T^\times denotes $T - \{0\}$.

For simplicity, $E \setminus a$ and $E \cup a$ denote $E \setminus \{a\}$ and $E \cup \{a\}$ respectively.

The **support** of $X \in T^E$ is $\underline{X} := \{e \in E \mid X(e) \neq 0\}$. The **zero set** of X is $X^0 := \{e \in E \mid X(e) = 0\}$.

For $S \subseteq T^E$, $\text{supp}(S)$ or \underline{S} denotes the set of supports of elements of S , and $\text{MinSupp}(S)$ denotes the set of elements of S of minimal support.

We will always view a skew tract T as being equipped with an involution $x \mapsto \bar{x}$.

First, we will talk about modular pairs and modular family in T -matroids.

Definition 2.9. [BB19] Let E be a set and let \mathcal{C} be a collection of pairwise incomparable nonempty subsets of E . We say that $C_1, C_2 \in \mathcal{C}$ form a **modular pair** in \mathcal{C} if the height of their join in the lattice $U(\mathcal{C})$ is 2. We say that $C_1, \dots, C_k \in \mathcal{C}$ form a **modular family** in \mathcal{C} if the height of their join in the lattice $U(\mathcal{C})$ is the same as the size of the family k .

Definition 2.10. [Su20] Let \mathcal{C} be a subset of T^E . We say that $X, Y \in \mathcal{C}$ form a **modular pair** in \mathcal{C} if $\underline{X}, \underline{Y}$ form a modular pair in the lattice of unions of supports of elements of \mathcal{C} . We say that $X_1, \dots, X_k \in \mathcal{C}$ form a **modular family** in \mathcal{C} if $\underline{X}_1, \dots, \underline{X}_k$ form a modular family in the lattice of unions of supports of elements of \mathcal{C} .

Following is a lemma for modular pair in terms of rank function of a matroid.

Lemma 2.11. *Let M be a matroid with rank function r . If Y_1, Y_2 form a modular pair of cocircuits of M , then $r(E - (Y_1 \cup Y_2)) = \text{rank}(M) - 2$.*

Proof. Let $d = \text{rank}(M)$. We know that for a cocircuit Y , $E - Y$ is a hyperplane of M . Thus by Definition of hyperplane, $r(E - Y) = d - 1$.

As $E - (Y_1 \cup Y_2)$ is a flat of M , then

$$r(E - (Y_1 \cup Y_2)) < r(E - Y_1) = d - 1.$$

By way of contradiction, we assume $r(E - (Y_1 \cup Y_2)) < d - 2$. Then there exists a flat $E - Z$ with $Z \in \mathcal{C}^*(M)$ such that

$$\begin{aligned} E - Y_1 \supsetneq E - Z \supsetneq E - (Y_1 \cup Y_2), \\ Y_1 \subsetneq Z \subsetneq Y_1 \cup Y_2. \end{aligned}$$

So (Y_1, Y_2) is not a modular pair, contradicting the assumption.

So $r(E - (Y_1 \cup Y_2)) = d - 2$. □

Definition 2.12. [Su20] Let E be a non-empty finite set and let $T = (G, N_G)$ be a skew tract. A subset \mathcal{C} of T^E is called the **T -circuit set of a weak left T -matroid \mathcal{M} on E** if \mathcal{C} satisfies the following axioms:

(C1) $0 \notin \mathcal{C}$.

(C2) (Symmetry) If $X \in \mathcal{C}$ and $\alpha \in T^\times$, then $\alpha \cdot X \in \mathcal{C}$.

- (C3) (Incomparability) If $X, Y \in \mathcal{C}$ and $\underline{X} \subseteq \underline{Y}$, then there exists $\alpha \in T^\times$ such that $Y = \alpha \cdot X$.
- (C4) (Modular Elimination) If $X, Y \in \mathcal{C}$ are a modular pair of T -circuits and $e \in E$ is such that $X(e) = -Y(e) \neq 0$, there exists a T -circuit $Z \in \mathcal{C}$ such that $Z(e) = 0$ and $X(f) + Y(f) - Z(f) \in N_G$ for all $f \in E$.

In the Modular Elimination axiom, we say Z **eliminates** e between X and Y .

A **weak right T -matroid** is defined analogously, with $\alpha \cdot X$ replaced by $X \cdot \alpha$ in (C2) and (C3).

If \mathcal{C} is the set of T -circuits of a weak (left or right) T -matroid \mathcal{M} with ground set E , then there is an underlying matroid (in the usual sense) $\underline{\mathcal{M}}$ on E whose circuits are the supports of the T -circuits of \mathcal{M} .

Definition 2.13. [Su20] The **rank** of \mathcal{M} is defined to be the rank of the underlying matroid $\underline{\mathcal{M}}$.

Definition 2.14. [Su20] A subset \mathcal{C} of T^E is called the **T -circuit set of a strong left T -matroid \mathcal{M} on E** if \mathcal{C} satisfies (C1), (C2) and (C3) in Definition 2.12 and the following stronger version of the Modular Elimination axiom (C4):

- (C4)' (Strong Modular Elimination) Suppose X_1, \dots, X_k and X are T -circuits of \mathcal{M} which together form a modular family of size $k + 1$ such that $\underline{X} \not\subseteq \bigcup_{1 \leq i \leq k} \underline{X}_i$, and for $1 \leq i \leq k$ let

$$e_i \in (\underline{X} \cap \underline{X}_i) \setminus \bigcup_{\substack{1 \leq j \leq k \\ j \neq i}} \underline{X}_j$$

be such that $X(e_i) = -X_i(e_i) \neq 0$. Then there exists a T -circuit $Z \in \mathcal{C}$ such that $Z(e_i) = 0$ for $1 \leq i \leq k$ and $X(f) + X_1(f) + \dots + X_k(f) - Z(f) \in N_G$ for every $f \in E$.

A **strong right T -matroid** is defined analogously, with $\alpha \cdot X$ replaced by $X \cdot \alpha$ in (C2) and (C3).

From the definition, it is easy to see that any strong left (resp. right) T -matroid on E is also a weak left (resp. right) T -matroid on E .

A **projective T -circuit of a (weak or strong) left T -matroid \mathcal{M}** is an equivalence class of T -circuits of \mathcal{M} under the equivalence relation $X_1 \sim X_2$ if and only if $X_1 = \alpha \cdot X_2$ for some $\alpha \in T^\times$. Analogously, a **projective T -circuit of a (weak or strong) right T -matroid \mathcal{M}** is an equivalence class of T -circuits of \mathcal{M} under the equivalence relation $X_1 \sim X_2$ if and only if $X_1 = X_2 \cdot \alpha$ for some $\alpha \in T^\times$.

As [BB19] shows, a matroid over a field T corresponds to a linear subspace of some T^n . A \mathbb{K} -matroid corresponds to a usual matroid. An \mathbb{S} -matroid is an oriented matroid. A \mathbb{P} -matroid is a phased matroid, defined in [AD12]. Weak matroids and strong matroids coincide over a field, \mathbb{K} and \mathbb{S} , but they do not coincide over \mathbb{P} .

There is a cryptomorphic characterization of weak and strong matroids over a skew tract T in terms of *quasi-Plücker coordinates*. First we define some terms.

Let T be a skew tract. For any collection $\mathcal{U} \subseteq T^E$ of sets with same size, we define

$$A_{\mathcal{U}} := \{(U, U') \in \mathcal{U} \times \mathcal{U} \mid |U \setminus U'| = 1\}.$$

Let N be a matroid with bases \mathcal{B} . We name the set of ordered pairs of adjacent bases $A_N := A_{\mathcal{B}}$.

Let F be a subset of E and let a_1, \dots, a_n be distinct elements of $E \setminus F$, we write $Fa_1 \dots a_n := F \cup \{a_1, \dots, a_n\}$ for simplicity.

Definition 2.15. [Su20] Let T be a skew tract and let N be a matroid on E with bases \mathcal{B} . Then $[\cdot] : A_N \rightarrow T$ are **weak left quasi-Plücker coordinates** if

- (P1) $[Fa, Fb] \cdot [Fb, Fa] = 1$ if $Fa, Fb \in \mathcal{B}$.
- (P2) $[Fac, Fbc] \cdot [Fab, Fac] \cdot [Fbc, Fba] = -1$ if $Fab, Fac, Fbc \in \mathcal{B}$.
- (P3) $[Fa, Fb] \cdot [Fb, Fc] \cdot [Fc, Fa] = 1$ if $Fa, Fb, Fc \in \mathcal{B}$.
- (P4) $[Fac, Fbc] = [Fad, Fbd]$ if $Fac, Fad, Fbc, Fbd \in \mathcal{B}$, and $Fab \notin \mathcal{B}$ or $Fcd \notin \mathcal{B}$.
- (P5) $-1 + [Fbd, Fab] \cdot [Fac, Fcd] + [Fad, Fab] \cdot [Fbc, Fcd] \in N_G$ if $Fac, Fad, Fbc, Fbd, Fab, Fcd \in \mathcal{B}$.

Definition 2.16. [Su20] Let d be the rank of N . $[\cdot] : A_N \rightarrow T$ are **strong left quasi-Plücker coordinates** if $[\cdot]$ satisfies (P1), (P2) and (P3) in Definition 2.15 and the following stronger versions of (P4) and (P5) :

(P4)' For any two subsets I, J of E with $|I| = d + 1$, $|J| = d - 1$ and $|I \setminus J| \geq 3$, we let $I_1 = \{x \in I \mid \text{both } I \setminus x \text{ and } Jx \text{ are bases of } N\}$. If $|I_1| = 2$ and we say $I = \{a, b\}$, then

$$[I \setminus a, I \setminus b] = [Jb, Ja].$$

(P5)' For any two subsets I, J of E with $|I| = d + 1$, $|J| = d - 1$ and $|I \setminus J| \geq 3$, we let $I_1 = \{x \in I \mid \text{both } I \setminus x \text{ and } Jx \text{ are bases of } N\}$. If $|I_1| \geq 3$, then for any $z \in I_1$,

$$-1 + \sum_{x \in I_1 \setminus z} [I \setminus x, I \setminus z] \cdot [Jx, Jz] \in N_G.$$

The definition of **weak right quasi-Plücker coordinates** and **strong right quasi-Plücker coordinates** are obtained by reversing the order of multiplication throughout.

Theorem 2.17. [Su20] *Let E be a finite set, let N be a matroid and let T be a skew tract. There is a natural bijection between the collections of strong (resp. weak) circuit sets $\mathcal{C} \subseteq T^E$ satisfying all circuit axioms and the collections of maps $[\cdot] : A_N \rightarrow T$ satisfying all strong (resp. weak) quasi-Plücker axioms.*

Parallel to matroids and oriented matroids, for every strong (resp. weak) left T -matroid \mathcal{M} of rank d on E with T -circuit set $\mathcal{C}(\mathcal{M})$, there is a strong (resp. weak) right T -matroid \mathcal{M}^* of rank $|E| - d$ with T -circuit set $\mathcal{C}^*(\mathcal{M}) := \text{MinSupp}(\{Y \in T^E \mid X \cdot Y \in N_G, X \in \mathcal{C}(\mathcal{M})\} - \{\mathbf{0}\})$, where T is a skew tract endowed with an involution $x \mapsto \bar{x}$. \mathcal{M}^* is called the **dual T -matroid** of \mathcal{M} . The T -circuits of \mathcal{M}^* are called the **T -cocircuits** of \mathcal{M} , and vice-versa.

If \mathcal{M} is a right T -matroid, then the dual matroid \mathcal{M}^* is a left T -matroid and the T -cocircuit set $\mathcal{C}^*(\mathcal{M})$ are obtained by reversing the order of multiplication throughout.

Lemma 2.18. [Su20] *(Dual pivoting property) Let T be a skew tract and let \mathcal{M} be left (weak or strong) T -matroid with T -cocircuit set \mathcal{C}^* and left quasi-Plücker coordinates $[\cdot]$. Let $Y \in \mathcal{C}^*$. Choose a maximal independent set J in Y^0 . Then for every $y_1, y_2 \in \underline{Y}$,*

$$Y(y_1)Y(y_2)^{-1} = \overline{[Jy_1, Jy_2]}.$$

Lemma 2.19. *Let cl be the closure operator of $\underline{\mathcal{M}}$. Let $Y_1, Y_2 \in \mathcal{C}^*(\mathcal{M})$ such that Y_1, Y_2 form a modular pair of T -cocircuits. Let I be a maximal independent set in $Y_1^0 \cap Y_2^0$. Then $|I| = d - 2$, and for every $e \in \underline{Y_1} \cap \underline{Y_2}$, there exists $Y_e \in \mathcal{C}^*(\mathcal{M})$ with $\underline{Y_e} = E \setminus \text{cl}(e \cup I)$.*

Proof. As Y_1, Y_2 form a modular pair in $\mathcal{C}^*(\mathcal{M})$, then $\underline{Y_1}, \underline{Y_2}$ form a modular pair in $\mathcal{C}^*(\underline{\mathcal{M}})$. Then by Lemma 2.11, $\text{rank}(Y_1^0 \cap Y_2^0) = d - 2$. So we can choose a maximal independent set $\{z_1, \dots, z_{d-2}\}$ in $Y_1^0 \cap Y_2^0$.

Let $e \in \underline{Y_1} \cap \underline{Y_2}$. Then $e \notin Y_1^0 \cup Y_2^0$. Thus $e \notin \text{cl}(\{z_1, \dots, z_{d-2}\})$. So $\text{rank}(\{e, z_1, \dots, z_{d-2}\}) = (d - 2) + 1 = d - 1$, and thus $\{e, z_1, \dots, z_{d-2}\}$ is a hyperplane of $\underline{\mathcal{M}}$. Then there exists $Y_e \in \mathcal{C}^*(\mathcal{M})$ with $\underline{Y_e} = E \setminus \text{cl}(\{e, z_1, \dots, z_{d-2}\})$. \square

2.3. Minors. Let $X \in T^E$ and let $A \subseteq E$. Define $X \setminus A \in T^{E \setminus A}$ by $(X \setminus A)(e) = X(e)$ for $e \in E \setminus A$.

For $\mathcal{U} \subseteq T^E$, define the **deletion** of A from \mathcal{U} as

$$\mathcal{U} \setminus A = \{X \setminus A \mid X \in \mathcal{U}, \underline{X} \cap A = \emptyset\}.$$

Define the **contraction** of A in \mathcal{U} as

$$\mathcal{U} / A = \text{MinSupp}(\{X \setminus A \mid X \in \mathcal{U}\}).$$

Theorem 2.20. [Su20] *$\mathcal{C} \setminus A$ is the set of T -circuits of a strong (resp. weak) left T -matroid $\mathcal{M} \setminus A$ on $E \setminus A$, called the **deletion** of \mathcal{M} by A , whose underlying matroid is $\underline{\mathcal{M}} \setminus A$.*

*Similarly, \mathcal{C} / A is the set of T -circuits of a strong (resp. weak) left T -matroid \mathcal{M} / A on $E \setminus A$, called the **contraction** of \mathcal{M} by A , whose underlying matroid is $\underline{\mathcal{M}} / A$.*

Moreover, $(\mathcal{M} \setminus A)^ = \mathcal{M}^* / A$ and $(\mathcal{M} / A)^* = \mathcal{M}^* \setminus A$.*

Lemma 2.21. [Su20] *Let N be a matroid on E , let T be a skew tract, let $[\cdot] : A_N \rightarrow T$ be weak left (resp. right) quasi-Plücker coordinates, and let A be a subset of E .*

(1) (Contraction) Let I_A be a maximal independent subset of A in N . Define $[\cdot]/A : A_{N/A} \rightarrow T$ by

$$[B, B']/A := [B \cup I_A, B' \cup I_A]$$

for all $(B, B') \in A_{N/A}$.

$[\cdot]/A$ are weak left (resp. right) quasi-Plücker coordinates of N/A . If $[\cdot]$ are strong left (resp. right) quasi-Plücker coordinates, so is $[\cdot]/A$. The definition of $[\cdot]/A$ is independent of the choice of I_A .

(2) (Deletion) Let $J_A \subseteq A$ be such that $(E \setminus A) \cup J_A$ spans N . Define $[\cdot] \setminus A : A_{N \setminus A} \rightarrow T$ by

$$[B, B'] \setminus A := [B \cup J_A, B' \cup J_A]$$

for all $(B, B') \in A_{N \setminus A}$.

$[\cdot] \setminus A$ are weak left (resp. right) quasi-Plücker coordinates of $N \setminus A$. If $[\cdot]$ are strong left (resp. right) quasi-Plücker coordinates, so is $[\cdot] \setminus A$. The definition of $[\cdot] \setminus A$ is independent of the choice of J_A .

Definition 2.22. Let T be a skew tract, let E be a non-empty finite set, and let $\mathcal{U} \subseteq T^E$. A function $f : \mathcal{U} \rightarrow T$ is called **right T^\times -equivariant** if it satisfies

$$f(U \cdot \alpha) = f(U) \cdot \alpha,$$

for all $U \in \mathcal{U}$ and all $\alpha \in T^\times$.

Similarly, a function $g : \mathcal{U} \rightarrow T$ is called **left T^\times -equivariant** if it satisfies

$$g(\beta \cdot V) = \beta \cdot g(V),$$

for all $V \in \mathcal{U}$ and all $\beta \in T^\times$.

If T is a (commutative) tract, then a function is called **T^\times -equivariant** if it is both left and right T^\times -equivariant.

Proposition 2.23. Let \mathcal{M} be a left (resp. right) T -matroid on E and let $f : \mathcal{C}^*(\mathcal{M}) \rightarrow T$ be a right (resp. left) T^\times -equivariant function. Let $A \subseteq E$. We can get **induced** maps $f/A : \mathcal{C}^*(\mathcal{M}/A) \rightarrow T$ on $\mathcal{C}^*(\mathcal{M}/A)$ and $f \setminus A : \mathcal{C}^*(\mathcal{M} \setminus A) \rightarrow T$ on $\mathcal{C}^*(\mathcal{M} \setminus A)$ by

$$(f/A)(Z) = f(Y),$$

$$(f \setminus A)(U) = f(X),$$

where $Z = Y \setminus A$, $Y \in \mathcal{C}^*(\mathcal{M})$, $\underline{Y} \cap A = \emptyset$, and $U = X \setminus A$, $X \in \mathcal{C}^*(\mathcal{M})$.

2.4. Rescaling.

Definition 2.24. [Su20] Let T be a skew tract, let $X \in T^E$ and let $\rho : E \rightarrow T^\times$. Then **right rescaling** X by ρ yields the vector $X \cdot \rho \in T^\times$ with entries $(X \cdot \rho)(e) = X(e) \cdot \rho(e)$ for all $e \in E$. Similarly, **left rescaling** gives a vector $\rho \cdot X$. We use ρ^{-1} for the function from E to T^\times such that $\rho^{-1}(e) = \rho(e)^{-1}$ for all $e \in E$.

Lemma 2.25. [Su20] Let \mathcal{M} be a weak (resp. strong) left T -matroid on E with T -circuit set \mathcal{C} and T -cocircuit set \mathcal{D} and let $\rho : E \rightarrow T^\times$. Then $\mathcal{C} \cdot \rho^{-1}$ and $\rho \cdot \mathcal{D}$ are the T -circuit set and T -cocircuit set of a weak (resp. strong) left T -matroid \mathcal{M}^ρ , where

$$\mathcal{C} \cdot \rho^{-1} := \{X \cdot \rho^{-1} \mid X \in \mathcal{C}\} \text{ and } \rho \cdot \mathcal{D} := \{\rho \cdot Y \mid Y \in \mathcal{D}\}.$$

\mathcal{M}^ρ is called the T -matroid arising from \mathcal{M} by **right rescaling**.

2.5. Crapo characterization of extension. In this subsection, we will first show a useful lemma due to Crapo. Then we will present Crapo's result on extension of matroids which we are going to generalize to T -matroids.

Lemma 2.26. [Cra65, BLVS⁺99] The hyperplanes of a single-element extension \widetilde{M} of a matroid M by p are given by one of the following two types:

(1) either H or $H \cup p$, for every hyperplane H of M , and

- (2) the sets $G \cup p$, where $G = H_1 \cap H_2$ is an intersubsection of two hyperplanes of M for which there is no hyperplane $H \supset G$ of M such that $H \cup p$ is a hyperplane of \widetilde{M} .

Definition 2.27. Let \mathcal{M} be a T -matroid. We say that a function $\sigma : \mathcal{C}^*(\mathcal{M}) \rightarrow T$ **defines** an extension of a minor of \mathcal{M} if and only if the map induced by σ is a localization of this minor.

Theorem 2.28. [Cra65] *Let M be a matroid with cocircuit set $\mathcal{C}^*(M)$. Then, for a function $\sigma : \mathcal{C}^*(M) \rightarrow \{0, 1\}$, which to every $Y \in \mathcal{C}^*(M)$ assigns a signature $\sigma(Y) \in \{0, 1\}$, the following statements are equivalent:*

- (1) σ defines a single-element extension \widetilde{M} of M .
(2) σ defines a single-element extension of every rank 2 contraction of M .

3. EXTENSION AND LOCALIZATION

In this section, we will introduce single-element extensions of matroids over skew tracts and localizations, and show that localizations characterize extensions.

Definition 3.1. Let T be a skew tract and let \mathcal{M} be a weak (resp. strong) left (resp. right) T -matroid on E . A weak (resp. strong) **extension** of \mathcal{M} is a weak (resp. strong) left (resp. right) T -matroid $\widetilde{\mathcal{M}}$ on a ground set \widetilde{E} that contains E , such that the deletion $\widetilde{\mathcal{M}} \setminus (\widetilde{E} - E)$ is equal to \mathcal{M} .

$\widetilde{\mathcal{M}}$ is a weak (resp. strong) **single-element extension** of \mathcal{M} if $|\widetilde{E} \setminus E| = 1$, that is, $\widetilde{E} = E \cup p$ for some $p \notin E$. So, $\widetilde{\mathcal{M}} \setminus p = \mathcal{M}$.

We will exclude the *trivial* case where p is a coloop of $\widetilde{\mathcal{M}}$ (equivalently, if $\text{rank}(\widetilde{\mathcal{M}}) = \text{rank}(\mathcal{M}) + 1$) as $\mathcal{C}^*(\widetilde{\mathcal{M}}) = \{Xp^0 : X \in \mathcal{C}^*(\mathcal{M})\} \cup \{E^0p^\alpha : \alpha \in T^\times\}$. Thus all single-element extensions considered in this paper are **non-trivial**.

If $Y \in T^E$, $p \notin E$ and $\alpha \in T$, then we denote by (Y, α) (or Yp^α) to denote the extension of Y to $E \cup p$ with $Y(p) = \alpha$ when there is no confusion.

Proposition 3.2. *Let T be a skew tract and let \mathcal{M} be a weak (resp. strong) left T -matroid on E with T -cocircuit set $\mathcal{C}^*(\mathcal{M}) \subseteq T^E$. Let $\widetilde{\mathcal{M}}$ be a weak (resp. strong) single-element extension of \mathcal{M} by an element p with T -cocircuit set $\mathcal{C}^*(\widetilde{\mathcal{M}}) \subseteq T^{E \cup p}$. Then for every T -cocircuit $Y \in \mathcal{C}^*(\mathcal{M})$, there is a unique way to extend Y to a T -cocircuit of $\widetilde{\mathcal{M}}$: there is a unique function*

$$\sigma : \mathcal{C}^*(\mathcal{M}) \rightarrow T$$

such that

$$\{(Y, \sigma(Y)) : Y \in \mathcal{C}^*(\mathcal{M})\} \subseteq \mathcal{C}^*(\widetilde{\mathcal{M}}).$$

That is, $(Y, \sigma(Y))$ is a T -cocircuit of $\widetilde{\mathcal{M}}$ for every T -cocircuit Y of \mathcal{M} . Furthermore, σ is right T^\times -equivariant.

The statement also holds when \mathcal{M} is a (weak or strong) right T -matroid and σ is left T^\times -equivariant.

Definition 3.3. The functions σ that correspond to weak (resp. strong) single-element extensions (via Proposition 3.2) are called weak (resp. strong) **localizations**.

The definition of **localizations for right T -matroids** are obtained by reversing the order of multiplication throughout.

Note that any strong T -matroid on E is a weak T -matroid on E , and any weak T -matroid of rank ≤ 3 on E is also a strong T -matroid on E .

If \mathcal{M} is a weak (resp. strong) T -matroid, then of course extensions of \mathcal{M} are weak (resp. strong) T -matroid and localizations are weak (resp. strong). We will omit “weak (resp. strong)” if theorems, propositions and lemmas are true for both weak and strong cases.

Proof of Proposition 3.2. Let $Y \in \mathcal{C}^*(\mathcal{M})$. By Theorem 2.20, $Y = \widetilde{Y} \setminus p$ for some $\widetilde{Y} \in \mathcal{C}^*(\widetilde{\mathcal{M}})$. By Incompatibility in $\mathcal{C}^*(\widetilde{\mathcal{M}})$, \widetilde{Y} is uniquely defined. Define $\sigma(Y) = \widetilde{Y}(p)$. Thus $(Y, \sigma(Y)) \in \mathcal{C}^*(\widetilde{\mathcal{M}})$.

Also for all $\alpha \in T^\times$, $(Y, \sigma(Y)) \cdot \alpha \in \mathcal{C}^*(\widetilde{\mathcal{M}})$, by Symmetry. That is, $(Y \cdot \alpha, \sigma(Y) \cdot \alpha) \in \mathcal{C}^*(\widetilde{\mathcal{M}})$.

So

$$\sigma(Y \cdot \alpha) = \sigma(Y) \cdot \alpha.$$

and so σ is right T^\times -equivariant. \square

For the remainder of this section, we take \mathcal{M} to be a left T -matroid of rank d on E with T -cocircuit set $\mathcal{C}^*(\mathcal{M})$ and left quasi-Plücker coordinates $[\cdot]$, $\widetilde{\mathcal{M}}$ to be an extension of \mathcal{M} by p , and $\sigma : \mathcal{C}^*(\mathcal{M}) \rightarrow T$ to be the corresponding localization of \mathcal{M} . Let cl be the closure operator of $\underline{\mathcal{M}}$.

Lemma 3.4. *Let \mathcal{B} be the set of basis of \mathcal{M} . The set of basis of $\widetilde{\mathcal{M}}$ is*

$$\widetilde{\mathcal{B}} = \mathcal{B} \cup \{Fp \subseteq E \cup p \mid |F| = d-1, E \setminus \text{cl}(F) = \underline{Y} \text{ and } \sigma(Y) \neq 0 \text{ for some } Y \in \mathcal{C}^*(\mathcal{M})\}.$$

Proof. As $\mathcal{M} = \widetilde{\mathcal{M}} \setminus p$ and $\text{rank}(\mathcal{M}) = \text{rank}(\widetilde{\mathcal{M}})$, we know that the independent sets $\mathcal{I}(\mathcal{M}) = \mathcal{I}(\widetilde{\mathcal{M}}) \cap \mathcal{P}(E)$ and $\text{rank}(\widetilde{\mathcal{M}}) = \text{rank}(\mathcal{M})$. So $\mathcal{B} \subseteq \widetilde{\mathcal{B}}$ and for $B \in \widetilde{\mathcal{B}} \setminus \mathcal{B}$, $B = Fp$ for some $F \in \mathcal{I}(\mathcal{M})$. So we only need to prove that

$$\widetilde{\mathcal{B}} \setminus \mathcal{B} = \{Fp \subseteq E \cup p \mid |F| = d-1, E \setminus \text{cl}(F) = \underline{Y} \text{ and } \sigma(Y) \neq 0 \text{ for some } Y \in \mathcal{C}^*(\mathcal{M})\}.$$

For \subseteq , let $B \in \widetilde{\mathcal{B}} \setminus \mathcal{B}$ with $B = Fp$ and $F \in \mathcal{I}(\mathcal{M})$. As $|F| = d-1$, then there exists $Y \in \mathcal{C}^*(\mathcal{M})$ such that $E \setminus \text{cl}(F) = \underline{Y}$. We claim that $\sigma(Y) \neq 0$. Otherwise, $Yp^0 \in \mathcal{C}^*(\widetilde{\mathcal{M}})$. Then $p \notin \widetilde{E} \setminus \text{cl}_{\widetilde{\mathcal{M}}}(F)$ and this contradicts that Fp is a basis of $\widetilde{\mathcal{M}}$.

For \supseteq , let F be an independent set in \mathcal{M} with $|F| = d-1$. Then there exists $Y \in \mathcal{C}^*(\mathcal{M})$ such that $E \setminus \text{cl}(F) = \underline{Y}$. If $\sigma(Y) \neq 0$, then $p \in \widetilde{E} \setminus \text{cl}_{\widetilde{\mathcal{M}}}(F)$. So $Fp \in \widetilde{\mathcal{B}}$. If $\sigma(Y) = 0$, then $p \notin \widetilde{E} \setminus \text{cl}_{\widetilde{\mathcal{M}}}(F)$. So $Fp \notin \widetilde{\mathcal{B}}$. \square

Lemma 3.5. *Let $[\cdot]_{\widetilde{\mathcal{M}}}$ be left quasi-Plücker coordinates for $\widetilde{\mathcal{M}}$. Let $F \subseteq E$ be independent in \mathcal{M} with $|F| = d-1$ and let $Y \in \mathcal{C}^*(\mathcal{M})$ with $\underline{Y} = E \setminus \text{cl}(F)$. Let $y \in \underline{Y}$. If $\sigma(Y) \neq 0$, then*

$$\sigma(Y) \cdot Y(y)^{-1} = \overline{[Fp, Fy]_{\widetilde{\mathcal{M}}}}.$$

Proof. This is proved by Lemma 2.18. \square

Proposition 3.6. *The left T -coordinates $[\cdot]_p : A_{\widetilde{\mathcal{M}}} \rightarrow T$ defined by*

$$[Fs, Ft]_p = \begin{cases} \frac{[Fs, Ft]}{\sigma(Y) \cdot Y(t)^{-1}} & \text{if } p \notin Fst, \\ \frac{Y(s) \cdot \sigma(Y)^{-1}}{[Fs, Ft]_{\widetilde{\mathcal{M}}}} & \text{if } p = s \text{ and } Y \in \mathcal{C}^*(\mathcal{M}) \text{ with } \underline{Y} = E \setminus \text{cl}(F), \\ \frac{[Gsg, Gtg]}{[Fs, Ft]_{\widetilde{\mathcal{M}}}} & \text{if } p = t \text{ and } Y \in \mathcal{C}^*(\mathcal{M}) \text{ with } \underline{Y} = E \setminus \text{cl}(F), \\ \frac{[Gsg, Gtg]}{[Fs, Ft]_{\widetilde{\mathcal{M}}}} & \text{if } p \in F, G = F \setminus \{p\}, Gst \notin \mathcal{B} \text{ and } Gsg, Gtg \in \mathcal{B} \\ & \text{for some } g \in E, \\ \frac{-\overline{Y_t(s) \cdot \sigma(Y_t)^{-1} \cdot \sigma(Y_s) \cdot Y_s(t)^{-1}}}{[Fs, Ft]_{\widetilde{\mathcal{M}}}} & \text{if } p \in F, G = F \setminus \{p\}, Gst \in \mathcal{B}, Y_i \in \mathcal{C}^*(\mathcal{M}) \text{ with} \\ & \underline{Y}_i = E \setminus \text{cl}(Gi) \text{ for } i \in \{s, t\}. \end{cases} \quad (2)$$

are left quasi-Plücker coordinates of $\widetilde{\mathcal{M}}$. In particular, $\widetilde{\mathcal{M}}$ is uniquely determined by $[\cdot]_p$.

Proof. Let Fs, Ft be adjacent bases of $\widetilde{\mathcal{M}}$ and let $[\cdot]_{\widetilde{\mathcal{M}}}$ be left quasi-Plücker coordinates of $\widetilde{\mathcal{M}}$.

If $p \notin Fst$, then Fs and Ft are also adjacent bases of \mathcal{M} . Then there exists $Y \in \mathcal{C}^*(\mathcal{M})$ such that $\underline{Y} = E \setminus \text{cl}(F)$ and $\widetilde{Y} := (Y, \sigma(Y) \in \mathcal{C}^*(\widetilde{\mathcal{M}}))$. So $[Fs, Ft]_{\widetilde{\mathcal{M}}} = \overline{\widetilde{Y}(s) \cdot \widetilde{Y}(t)^{-1}} = \overline{Y(s) \cdot Y(t)^{-1}} = [Fs, Ft]$ by Lemma 2.18.

If $p \in \{s, t\}$, then there exists $Y \in \mathcal{C}^*(\mathcal{M})$ such that $\underline{Y} = E \setminus \text{cl}(F)$. If $p = s$, then by Lemma 3.5, we have $[Fp, Ft]_{\widetilde{\mathcal{M}}} = \sigma(Y) \cdot Y(t)^{-1}$. If $p = t$, then by (P1) and Lemma 3.5, we have $[Fs, Fp]_{\widetilde{\mathcal{M}}} = ([Fp, Fs]_{\widetilde{\mathcal{M}}})^{-1} = (\sigma(Y) \cdot Y(s)^{-1})^{-1} = \overline{Y(s) \cdot \sigma(Y)^{-1}}$.

If $p \in F$, then let $G = F \setminus \{p\}$. As $Fs, Ft \in \widetilde{\mathcal{B}}$, then both Gs and Gt are independent sets in \mathcal{M} . Now we consider Gst .

If $Gst \notin \tilde{\mathcal{B}}$, then we let $g \in E$ such that $Gsg, Gtg \in \tilde{\mathcal{B}}$. We also have $Gsg, Gtg \in \mathcal{B}$. So by (P4) and above argument, $[Fs, Ft]_{\tilde{\mathcal{M}}} = [Gsg, Gtg]_{\tilde{\mathcal{M}}} = [Gsg, Gtg]$.

If $Gst \in \tilde{\mathcal{B}}$, then $Gst \in \mathcal{B}$. So there exist $Y_i \in \mathcal{C}^*(\mathcal{M})$ such that $\underline{Y}_i = E \setminus \text{cl}(Gi)$ for $i \in \{s, t\}$. As $Gst \in \mathcal{B}$, then $t \in \underline{Y}_s$ and $s \in \underline{Y}_t$. By (P2), we have $[Gsp, Gtp]_{\tilde{\mathcal{M}}} \cdot [Gst, Gsp]_{\tilde{\mathcal{M}}} \cdot [Gtp, Gst]_{\tilde{\mathcal{M}}} = -1$. Then by (P1) and above argument, we have

$$[Gsp, Gtp]_{\tilde{\mathcal{M}}} = -[Gst, Gtp]_{\tilde{\mathcal{M}}} \cdot [Gsp, Gst]_{\tilde{\mathcal{M}}} = \overline{-Y_t(s) \cdot \sigma(Y_t)^{-1} \cdot \sigma(Y_s) \cdot Y_s(t)^{-1}}.$$

So,

$$[Fs, Ft]_{\tilde{\mathcal{M}}} = \begin{cases} [Fs, Ft] & \text{if } p \notin Fst, \\ \frac{\sigma(Y) \cdot Y(t)^{-1}}{Y(s) \cdot \sigma(Y)^{-1}} & \text{if } p = s \text{ and } Y \in \mathcal{C}^*(\mathcal{M}) \text{ with } \underline{Y} = E \setminus \text{cl}(F), \\ \frac{[Gsg, Gtg]}{-Y_t(s) \cdot \sigma(Y_t)^{-1} \cdot \sigma(Y_s) \cdot Y_s(t)^{-1}} & \text{if } p = t \text{ and } Y \in \mathcal{C}^*(\mathcal{M}) \text{ with } \underline{Y} = E \setminus \text{cl}(F), \\ [Gsg, Gtg] & \text{if } p \in F, G = F \setminus \{p\}, Gst \notin \mathcal{B} \text{ and } Gsg, Gtg \in \mathcal{B} \\ & \text{for some } g \in E, \\ [Gsp, Gtp]_{\tilde{\mathcal{M}}} \cdot [Gst, Gsp]_{\tilde{\mathcal{M}}} \cdot [Gtp, Gst]_{\tilde{\mathcal{M}}} & \text{if } p \in F, G = F \setminus \{p\}, Gst \in \mathcal{B}, Y_i \in \mathcal{C}^*(\mathcal{M}) \text{ with} \\ & \underline{Y}_i = E \setminus \text{cl}(Gi) \text{ for } i \in \{s, t\}. \end{cases}$$

As $[\cdot]_{\tilde{\mathcal{M}}}$ is uniquely determined by σ , thus $\tilde{\mathcal{M}}$ is uniquely determined by σ . \square

If \mathcal{M} is a right T -matroid, then the right quasi-Plücker coordinates of the extension $\tilde{\mathcal{M}}$ are defined analogously by reversing the order of multiplication throughout.

In subsection 1.1.1, we talked about how to find the signed cocircuit set of the extended oriented matroid, determined by a localization. Now we will generalize that to matroids over skew tracts.

First, for matroid over skew tracts, we would like to find all $X \in \mathcal{C}^*(\tilde{\mathcal{M}})$ that arise via modular elimination by p . The following lemma characterizes those T -cocircuits.

Lemma 3.7. *Let (Y_1, Y_2) be a modular pair of T -cocircuits of \mathcal{M} with $\sigma(Y_1) = -\sigma(Y_2) \neq 0$. Then there exists a unique $X \in \mathcal{C}^*(\tilde{\mathcal{M}})$ such that $X(p) = 0$ and $Y_1(f) + Y_2(f) - X(f) \in N_G$ for all $f \in E$. Further, if $e \in \underline{Y}_1 \cap \underline{Y}_2$, then*

$$X(e) = -Y_1(e) \cdot \sigma(Y_1)^{-1} \cdot \sigma(Y_e) \cdot Y_e(e_1)^{-1} \cdot Y_2(e_1)$$

where $Y_e \in \mathcal{C}^*(\mathcal{M})$ with $\underline{Y}_e = E \setminus \text{cl}((Y_1^0 \cap Y_2^0) \cup e)$ and $e_1 \in \underline{Y}_2 \setminus \underline{Y}_1$.

Recall that such a Y_e was guaranteed by Lemma 2.19.

Proof. The Modular Elimination axiom in $\tilde{\mathcal{M}}$ shows that there exists $X \in \mathcal{C}^*(\tilde{\mathcal{M}})$ such that X eliminates p between $(Y_1, \sigma(Y_1))$ and $(Y_2, \sigma(Y_2))$, that is $X(p) = 0$ and $Y_1(f) + Y_2(f) - X(f) \in N_G$ for all $f \in E$.

Now, let $e \in \underline{Y}_1 \cap \underline{Y}_2$. Let us find the value of $X(e)$.

Let F be a maximal independent set in $Y_1^0 \cap Y_2^0$. Then $|F| = d - 2$. Let $e_1 \in \underline{Y}_2 \setminus \underline{Y}_1$. Thus $X(e_1) = Y_2(e_1)$ and $\underline{Y}_1 = E \setminus \text{cl}(Fe_1)$. So $Fe_1p, Fe_1e, Fep \in \tilde{\mathcal{B}}$. Let $Y_e \in \mathcal{C}^*(\mathcal{M})$ with $\underline{Y}_e = E \setminus \text{cl}(Fe)$.

By Dual pivoting property, we have that $\overline{X(e) \cdot X(e_1)^{-1}} = [Fep, Fe_1p]_p$. By Proposition 3.6, we also have that

$$[Fep, Fe_1p]_p = \overline{-Y_1(e) \cdot \sigma(Y_1)^{-1} \cdot \sigma(Y_e) \cdot Y_e(e_1)^{-1}}.$$

Then

$$\overline{X(e) \cdot X(e_1)^{-1}} = \overline{-Y_1(e) \cdot \sigma(Y_1)^{-1} \cdot \sigma(Y_e) \cdot Y_e(e_1)^{-1}}.$$

So

$$X(e) = -Y_1(e) \cdot \sigma(Y_1)^{-1} \cdot \sigma(Y_e) \cdot Y_e(e_1)^{-1} \cdot Y_2(e_1). \quad \square$$

If \mathcal{M} is a right T -matroid, then the value of $X(e)$ is obtained by reversing the order of multiplication throughout.

Definition 3.8. We denote X as in Lemma 3.7 by $\text{Mod}(Y_1, Y_2, p)$.

Proposition 3.9. *The set of T -cocircuits of $\widetilde{\mathcal{M}}$ is*

$$\begin{aligned} \mathcal{C}^*(\widetilde{\mathcal{M}}) = & \{(Y, \sigma(Y)) : Y \in \mathcal{C}^*(\mathcal{M})\} \cup \\ & \{\text{Mod}(Y_1, Y_2, p) : Y_1, Y_2 \in \mathcal{C}^*(\mathcal{M}), (Y_1, Y_2) \text{ is a modular pair of } T\text{-cocircuits,} \\ & \text{and } \sigma(Y_1) = -\sigma(Y_2) \neq 0\}. \end{aligned}$$

Proof. (\supseteq): Proposition 3.2 and Lemma 3.7 show that the right side of the equation is contained in $\mathcal{C}^*(\widetilde{\mathcal{M}})$.

(\subseteq): As $\widetilde{\mathcal{M}} \setminus p = \widetilde{\mathcal{M}} \setminus p$, then $\widetilde{\mathcal{M}}$ is also a single-element extension of \mathcal{M} by p .

Let $X \in \mathcal{C}^*(\widetilde{\mathcal{M}})$. Thus X^0 is a hyperplane of $\widetilde{\mathcal{M}}$. Lemma 2.26 describes 2 possible types for X^0 .

If X^0 is of type (1), then either X^0 or $X^0 \setminus p$ is a hyperplane of \mathcal{M} . So there exists $Y' \in \mathcal{C}^*(\mathcal{M})$ such that $\underline{Y}' = \underline{X} \setminus p$ or $\underline{Y}' = \underline{X}$. As $(Y', \sigma(Y')) \in \mathcal{C}^*(\widetilde{\mathcal{M}})$, by Incomparability, $X = (Y', \sigma(Y')) \cdot \alpha$, for some $\alpha \in T^\times$. So $X \in \{(Y, \sigma(Y)) : Y \in \mathcal{C}^*(\mathcal{M})\}$.

If X^0 is of type (2), then $p \notin \underline{X}$. That is, $X = (Z, 0)$, for some $Z \in T^E$. And $Z^0 = H_1 \cap H_2$, where H_1 and H_2 are two hyperplanes of \mathcal{M} and there is no hyperplane $H \supset Z^0$ of \mathcal{M} such that $H \cup p$ is a hyperplane of $\widetilde{\mathcal{M}}$.

Let $Y_1, Y_2 \in \mathcal{C}^*(\mathcal{M})$ such that $Y_1^0 = H_1$ and $Y_2^0 = H_2$. Then $\underline{Z} = \underline{Y}_1 \cup \underline{Y}_2$. As $\text{rank}(H_1) = \text{rank}(H_2) = d-1$, then $\text{rank}(H_1 \cap H_2) \leq d-2$. Since $\text{rank}(X^0) = d-1$ and $H_1 \cap H_2 = Z^0 = X^0 \setminus p$, then $\text{rank}(H_1 \cap H_2) \geq d-2$. So $\text{rank}(H_1 \cap H_2) = d-2$. Thus (Y_1, Y_2) is a modular pair of T -cocircuits. As $H_i \supset Z^0$, $H_i \cup p$ is not a hyperplane of $\widetilde{\mathcal{M}}$, for $i = 1, 2$. So $\sigma(Y_i) \neq 0$, for $i = 1, 2$. Without loss of generality, choose Y_1, Y_2 such that $\sigma(Y_1) = -\sigma(Y_2) \neq 0$ and $Y_1(e) = Z(e)$, for $e \in \underline{Y}_1 \setminus \underline{Y}_2$.

By Modular Elimination in $\widetilde{\mathcal{M}}$, there exists $X_1 \in \mathcal{C}^*(\widetilde{\mathcal{M}})$ such that $X_1(p) = 0$ and for every $e \in E$, $Y_1(e) + Y_2(e) - X_1(e) \in N_G$. So $\underline{X}_1 \subseteq \underline{Y}_1 \cup \underline{Y}_2$.

As $\underline{X} = \underline{Z} = \underline{Y}_1 \cup \underline{Y}_2$, $\underline{X}_1 \subseteq \underline{X}$. By Incomparability, $X = X_1 \cdot \alpha$, for some $\alpha \in T^\times$. As $X_1(e) = Y_1(e)$, for all $e \in \underline{Y}_1 \setminus \underline{Y}_2$, then $\alpha = 1$. So $X = X_1$.

So $X = \text{Mod}(Y_1, Y_2, p)$. □

Corollary 3.10. *The support of $\text{Mod}(Y_1, Y_2, p)$ is equal to $\underline{Y}_1 \cup \underline{Y}_2$.*

It follows from the proof of Proposition 3.6 and the proof of Proposition 3.9 that the characterization of quasi-Plücker coordinates $[\cdot]_p$ and the characterization of T -cocircuit set $\mathcal{C}^*(\widetilde{\mathcal{M}})$ also hold if \mathcal{M} is a strong T -matroid.

4. PATHETIC CANCELLATION PROPERTY

Recall (Theorem 1.3) that if a function $\sigma : \mathcal{C}^*(\mathcal{M}) \rightarrow \mathbb{S}$ defines a single-element extension of every rank 2 contraction of an oriented matroid \mathcal{M} , then it is a localization. But it is not always true for other skew tracts.

Now we will introduce a property for a skew tract T , which is necessary and sufficient for Theorem 1.3 to generalize to weak matroids over skew tracts (Theorem 1.5). Theorem 4.3 proves the necessity and Theorem 5.1 proves the sufficiency.

Definition 4.1. Let T be a skew tract. We say T satisfies the **Pathetic Cancellation Property** if for every $a, b, x, y, z \in T^\times$ with

$$\begin{aligned} 1 + a - x & \in N_G, \\ ax & = xa, \\ -1 + b - y & \in N_G, \\ by & = yb, \\ a + b - z & \in N_G, \\ a^{-1}zb^{-1} & = b^{-1}za^{-1}, \\ x + y - z & \in N_G, \end{aligned}$$

$$x^{-1}zy^{-1} = y^{-1}zx^{-1},$$

we have

$$xb - ay - z \in N_G.$$

The name *Pathetic Cancellation* comes from how the property behaves in a field. When T is a field, the hypothesis can be stated as

$$\begin{aligned} x &= 1 + a, \\ y &= -1 + b, \\ z &= a + b, \\ z &= x + y. \end{aligned}$$

and the conclusion can be stated as $z = xb - ay$.

It is a *cancellation* in a field as

$$xb - ay = (1 + a)b - a(-1 + b) = (a + b) + (ab - ab) = a + b = z.$$

And it is *Pathetic* because it needs all hypotheses, but when T is a field, the hypotheses become less and any three of them imply the fourth one and give the conclusion via cancellation.

Here are one example of hyperfields that does not satisfy Pathetic Cancellation.

Example 4.2. The example is over \mathbb{P} . Let $a = \frac{-1+i}{\sqrt{2}}$, $b = \frac{1+i}{\sqrt{2}}$, $x = \frac{\sqrt{3}+i}{2}$, $y = \frac{-1+\sqrt{3}i}{2}$, and $z = i$. It is easy to check that a, b, x, y, z satisfies all hypotheses in Definition 4.1. However, $z \notin xb \boxplus -ay = \left\{ \frac{-1+\sqrt{3}+i(1+\sqrt{3})}{2\sqrt{2}} \right\}$, as shown in Figure 4.

We depict a, b, x, y and z by labelled points on a picture of S^1 . The left circle in Figure 4 depicts a, b, x, y and z . The dashed lines indicate the hyperadditions $a \boxplus 1$, $-1 \boxplus b$, $a \boxplus b$ and $x \boxplus y$. And the right circle depicts $-ay$ and xb .

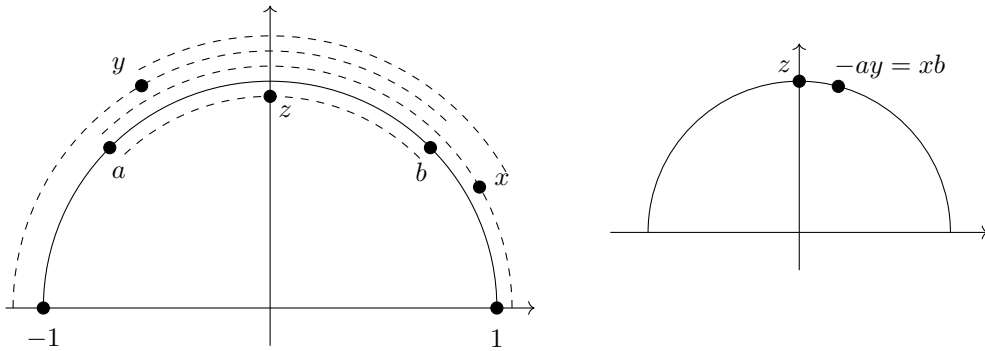

FIGURE 4. Illustration for Example 4.2

Theorem 4.3. *Let T be a skew tract not satisfying Pathetic Cancellation. There is a both weak and strong left T -matroid \mathcal{M} on E and a right T^\times -equivariant function $\sigma : \mathcal{C}^*(\mathcal{M}) \rightarrow T$ such that σ defines a single-element extension by a new element p on every rank 2 contraction of \mathcal{M} but σ is not a localization.*

Before showing the proof, we will first introduce a useful lemma for determining localizations of rank 2 T -matroids on three elements.

Lemma 4.4. *Let T be a skew tract, let \mathcal{M} be a uniform rank 2 left T -matroid on three elements with T -cocircuit set $\mathcal{C}^*(\mathcal{M})$, and let $\sigma : \mathcal{C}^*(\mathcal{M}) \rightarrow T$ be a right T^\times -equivariant function. Then σ is a localization if and only if there exist $Y_1, Y_2, Y_3 \in \mathcal{C}^*(\mathcal{M})$ such that Y_3 eliminates some element e between Y_1 and Y_2 , and $\sigma(Y_1) + \sigma(Y_2) - \sigma(Y_3) \in N_G$.*

Proof. Let E be the ground set of \mathcal{M} and $E = \{e_1, e_2, e_3\}$.

(\Rightarrow): We suppose that σ is a localization. As \mathcal{M} is a rank 2 T -matroid, then every pair of T -cocircuits of \mathcal{M} form a modular pair. Let $e \in E$ and (Y_1, Y_2) be a modular pair of T -cocircuits of \mathcal{M} with $Y_1(e) = -Y_2(e) \neq 0$. Without loss of generality, we may assume $e = e_3$, $Y_1(e_1) = 0$ and $Y_2(e_2) = 0$. There exists $Y_3 \in \mathcal{C}^*(\mathcal{M})$ such that Y_3 eliminates e_3 between Y_1 and Y_2 . Thus $Y_3(e_3) = 0$ and $Y_1(f) + Y_2(f) - Y_3(f) \in N_G$ for all $f \in E$. So $Y_3(e_1) = Y_2(e_1)$, $Y_3(e_2) = Y_1(e_2)$ and $\underline{Y_3} = \{e_1, e_2\}$.

Let $\widetilde{\mathcal{M}}$ be the extension of \mathcal{M} on $E \cup p$ determined by σ . As $(Y_1, \sigma(Y_1)), (Y_2, \sigma(Y_2))$ form a modular pair in $\mathcal{C}^*(\widetilde{\mathcal{M}})$ with $Y_1(e) = -Y_2(e)$, then there exists $\widetilde{Y} \in \mathcal{C}^*(\widetilde{\mathcal{M}})$ such that \widetilde{Y} eliminate e between $(Y_1, \sigma(Y_1))$ and $(Y_2, \sigma(Y_2))$. Thus $\widetilde{Y}(e) = 0$, $Y_1(f) + Y_2(f) - \widetilde{Y}(f) \in N_G$ for all $f \in E$, and $\sigma(Y_1) + \sigma(Y_2) - \widetilde{Y}(p) \in N_G$. So $\widetilde{Y}(e_1) = Y_2(e_1)$, $\widetilde{Y}(e_2) = Y_1(e_2)$ and $\{e_1, e_2\} \subseteq \underline{\widetilde{Y}} \subseteq \{e_1, e_2, p\}$.

Now let us look at the T -cocircuits $(Y_3, \sigma(Y_3))$ and \widetilde{Y} . As $\{e_1, e_2\} \subseteq \underline{(Y_3, \sigma(Y_3))} \subseteq \{e_1, e_2, p\}$ and $\{e_1, e_2\} \subseteq \underline{\widetilde{Y}} \subseteq \{e_1, e_2, p\}$, then either $\underline{(Y_3, \sigma(Y_3))} \subseteq \underline{\widetilde{Y}}$ or $\underline{\widetilde{Y}} \subseteq \underline{(Y_3, \sigma(Y_3))}$. By Symmetry, $\widetilde{Y} = (Y_3, \sigma(Y_3)) \cdot \alpha$ for some $\alpha \in T^\times$. As $Y_3(e_1) = Y_2(e_1) = \widetilde{Y}(e_1)$, then $\alpha = 1$. Thus $\widetilde{Y} = (Y_3, \sigma(Y_3))$. So $\sigma(Y_1) + \sigma(Y_2) - \sigma(Y_3) \in N_G$.

(\Leftarrow): We suppose that there exist $Y_1, Y_2, Y_3 \in \mathcal{C}^*(\mathcal{M})$ such that Y_3 eliminates some element e between Y_1 and Y_2 , and $\sigma(Y_1) + \sigma(Y_2) - \sigma(Y_3) \in N_G$. Then without loss of generality, we may assume $e = e_3$, $Y_1(e_1) = 0$ and $Y_2(e_2) = 0$. We list a representative from each projective T -cocircuit of \mathcal{M} in Table 1.

	e_1	e_2	e_3
Y_2	$Y_2(e_1)$	0	$-Y_1(e_3)$
Y_1	0	$Y_1(e_2)$	$Y_1(e_3)$
Y_3	$Y_2(e_1)$	$Y_1(e_2)$	0

TABLE 1

Let $Z \in T^{E \cup p}$ be such that

$$Z = (Y_2(e_1) \cdot \sigma(Y_2)^{-1}, -Y_1(e_2) \cdot \sigma(Y_1)^{-1}, -Y_1(e_3) \cdot (\sigma(Y_1)^{-1} + \sigma(Y_2)^{-1}), 0)$$

and let $\alpha \in T^\times$ be such that $\alpha = \sigma(Y_1)^{-1} + \sigma(Y_2)^{-1}$. Then we define a set $\widetilde{\mathcal{C}} \subseteq T^{E \cup p}$ by

$$\widetilde{\mathcal{C}} := \{(Y_1, \sigma(Y_1)) \cdot \beta : \beta \in T^\times\} \cup \{(Y_2, \sigma(Y_2)) \cdot \beta : \beta \in T^\times\} \cup \{(Y_3, \sigma(Y_3)) \cdot \beta : \beta \in T^\times\} \cup \{Z \cdot \beta : \beta \in T^\times\}.$$

We would like to show that $\widetilde{\mathcal{C}}$ is the T -cocircuit set of a rank 2 left T -matroid $\widetilde{\mathcal{M}}$ on the set $E \cup p$ and $\widetilde{\mathcal{M}}$ is the extension of \mathcal{M} determined by σ .

As \mathcal{M} is of rank 2, then every pair of T -cocircuits of \mathcal{M} is a modular pair.

As $\sigma(Y_1) + \sigma(Y_2) - \sigma(Y_3) \in N_G$, it is easy to verify that

$$Z = \text{Mod}(-Y_1 \cdot \sigma(Y_1)^{-1}, Y_2 \cdot \sigma(Y_2)^{-1}, p),$$

$$Z = \text{Mod}(Y_2 \cdot \alpha, -Y_3 \cdot \sigma(Y_1)^{-1}, p),$$

$$Z = \text{Mod}(-Y_1 \cdot \alpha, Y_3 \cdot \sigma(Y_2)^{-1}, p).$$

So σ is a localization. □

The statement also holds for a uniform rank 2 right T -matroid on three elements and a left T^\times -equivariant function.

Now we will give the proof of Theorem 4.3.

Proof of Theorem 4.3. As T does not satisfy Pathetic Cancellation, then there exist $a, b, x, y, z \in T^\times$ with $1 + a - x \in N_G$, $ax = xa$, $-1 + b - y \in N_G$, $by = yb$, $a + b - z \in N_G$, $a^{-1}zb^{-1} = b^{-1}za^{-1}$, $x + y - z \in N_G$ and $x^{-1}zy^{-1} = y^{-1}zx^{-1}$, but $xb - ay - z \notin N_G$.

Now we define a weak left T -matroid \mathcal{M} on the set $E = \{y_1, y_2, y_3, y_4\}$ of rank 3 with T -cocircuit set $\mathcal{C}^*(\mathcal{M})$. We list a representative from each projective T -cocircuit of \mathcal{M} in Table 2.

	y_1	y_2	y_3	y_4
Y_{23}	1	0	0	1
Y_{13}	0	1	0	b^{-1}
Y_{12}	0	0	1	a^{-1}
Y_{24}	1	0	$-a$	0
Y_{34}	-1	b	0	0
Y_{14}	0	b	$-a$	0

TABLE 2

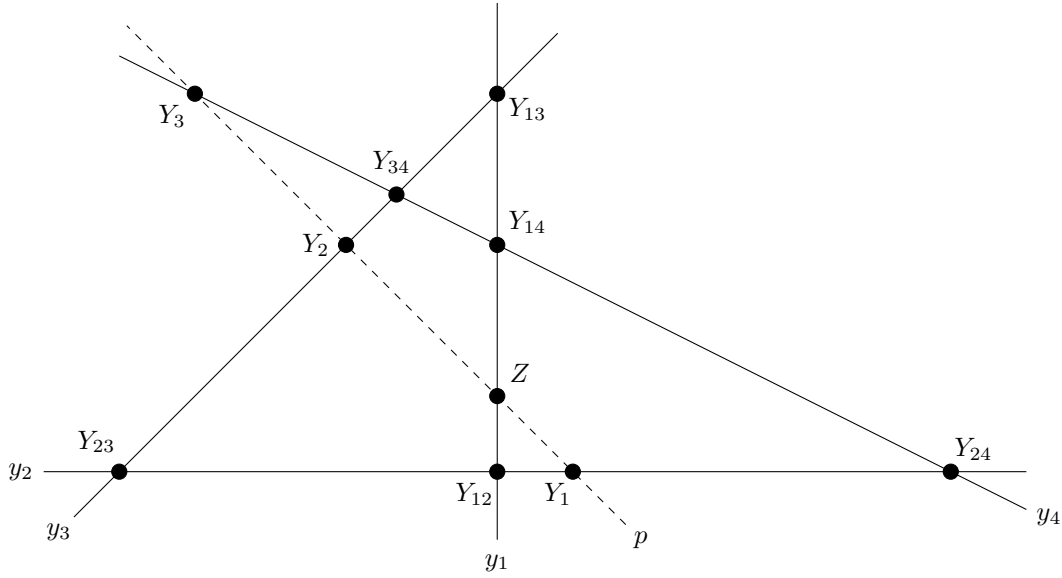

FIGURE 5. Collinearities for the counterexample

Figure 5 shows the collinearities for cocircuits of the underlying matroid on elements of E .

It is easy to check $\mathcal{C}^*(\mathcal{M})$ satisfies Modular Elimination. As \mathcal{M} is of rank 3 with fewer than 6 elements, \mathcal{M} is both a weak and a strong left T -matroid.

Let $\sigma : \mathcal{C}^*(\mathcal{M}) \rightarrow T$ be the right T -equivariant function such that

$$\begin{aligned}\sigma(Y_{23}) &= \sigma(Y_{13}) = 1, \\ \sigma(Y_{12}) &= -1, \\ \sigma(Y_{24}) &= x, \\ \sigma(Y_{34}) &= y\end{aligned}$$

and

$$\sigma(Y_{14}) = z.$$

First, we will verify that σ defines a single-element extension of every rank 2 contraction of \mathcal{M} using Lemma 4.4.

We can see that $Y_{13} \setminus y_1$, $Y_{12} \setminus y_1$ and $Y_{14} \setminus y_1$ are representatives for the T -cocircuits of the rank 2 contraction \mathcal{M}/y_1 . And $Y_{14} \setminus y_1$ eliminates y_4 between $(Y_{13} \setminus y_1) \cdot Y_{13}(y_4)^{-1}$ and $(Y_{12} \setminus y_1) \cdot (-Y_{12}(y_4)^{-1})$. We also have

$$\sigma(Y_{13}) \cdot Y_{13}(y_4)^{-1} + \sigma(Y_{12}) \cdot (-Y_{12}(y_4)^{-1}) - \sigma(Y_{14}) = b + a - z \in N_G.$$

So by Lemma 4.4, σ induces a function σ/y_1 which is a localization on \mathcal{M}/y_1 .

Similarly, $Y_{23}\setminus y_2, Y_{12}\setminus y_2$ and $Y_{24}\setminus y_2$ are representatives for the T -cocircuits of the rank 2 contraction \mathcal{M}/y_2 . And $Y_{24}\setminus y_2$ eliminates y_4 between $Y_{23}\setminus y_2$ and $(Y_{12}\setminus y_2) \cdot (-Y_{12}(y_4)^{-1})$. We also have

$$\sigma(Y_{23}) + \sigma(Y_{12}) \cdot (-Y_{12}(y_4)^{-1}) - \sigma(Y_{24}) = 1 + a - x \in N_G.$$

So by Lemma 4.4, σ induces a function σ/y_2 which is a localization on \mathcal{M}/y_2 .

Similarly, $Y_{23}\setminus y_3, Y_{13}\setminus y_3$ and $Y_{34}\setminus y_3$ are representatives for the T -cocircuits of the rank 2 contraction \mathcal{M}/y_3 . And $Y_{34}\setminus y_3$ eliminates y_4 between $-Y_{23}\setminus y_3$ and $(Y_{13}\setminus y_3) \cdot Y_{13}(y_4)^{-1}$. We also have

$$-\sigma(Y_{23}) + \sigma(Y_{13}) \cdot Y_{13}(y_4)^{-1} - \sigma(Y_{34}) = -1 + b - y \in N_G.$$

So by Lemma 4.4, σ induces a function σ/y_3 which is a localization on \mathcal{M}/y_3 .

Similarly, $Y_{24}\setminus y_4, Y_{34}\setminus y_4$ and $Y_{14}\setminus y_4$ are representatives for the T -cocircuits of the rank 2 contraction \mathcal{M}/y_4 . And $Y_{14}\setminus y_4$ eliminates y_1 between $Y_{24}\setminus y_4$ and $Y_{34}\setminus y_4$. We also have

$$\sigma(Y_{24}) + \sigma(Y_{34}) - \sigma(Y_{14}) = x + y - z \in N_G.$$

So by Lemma 4.4, σ induces a function σ/y_4 which is a localization on \mathcal{M}/y_4 .

So σ defines a single-element extension of every rank 2 contraction of \mathcal{M} .

Next we would like to show that σ is not a localization of \mathcal{M} . Suppose by way of contradiction that σ is a localization of \mathcal{M} . Let $\widetilde{\mathcal{M}}$ be the single-element extension of \mathcal{M} determined by σ . Now we list a representative from each projective T -cocircuit of $\widetilde{\mathcal{M}}$ in the form of $(Y, \sigma(Y))$, $Y \in \mathcal{C}^*(\mathcal{M})$ in Table 3.

	y_1	y_2	y_3	y_4	p
$(Y_{23}, \sigma(Y_{23}))$	1	0	0	1	1
$(Y_{13}, \sigma(Y_{13}))$	0	1	0	b^{-1}	1
$(Y_{12}, \sigma(Y_{12}))$	0	0	1	a^{-1}	-1
$(Y_{24}, \sigma(Y_{24}))$	1	0	$-a$	0	x
$(Y_{34}, \sigma(Y_{34}))$	-1	b	0	0	y
$(Y_{14}, \sigma(Y_{14}))$	0	b	$-a$	0	z

TABLE 3

By Proposition 3.9, the extension $\widetilde{\mathcal{M}}$ will also have T -cocircuits

$$\begin{aligned} Y_1 &= \text{Mod}(Y_{23}, Y_{12}, p), \\ Y_2 &= \text{Mod}(-Y_{23}, Y_{13}, p), \\ Z &= \text{Mod}(Y_{13}, Y_{12}, p), \\ Y_3 &= \text{Mod}(Y_{24} \cdot \sigma(Y_{24})^{-1}, Y_{34} \cdot (-\sigma(Y_{34})^{-1}), p). \end{aligned}$$

So by Lemma 3.7, we have

$$\begin{aligned} Y_1(y_1) &= Y_{23}(y_1) = 1 && \text{since } Y_{12}(y_1) = 0, \\ Y_1(y_2) &= 0 && \text{since } Y_{23}(y_2) = Y_{12}(y_2) = 0, \\ Y_1(y_3) &= Y_{12}(y_3) = 1 && \text{since } Y_{23}(y_3) = 0, \\ Y_1(y_4) &= -Y_{23}(y_4)\sigma(Y_{23})^{-1}\sigma(Y_{24})Y_{24}(y_3)^{-1}Y_{12}(y_3) = xa^{-1}, \end{aligned}$$

and so

$$Y_1 = (1, 0, 1, xa^{-1}, 0).$$

Similarly by Lemma 3.7, we have

$$Y_2(y_1) = -Y_{23}(y_1) = -1 \quad \text{since } Y_{13}(y_1) = 0,$$

$$\begin{aligned}
Y_2(y_2) &= Y_{13}(y_2) = 1 && \text{since } Y_{23}(y_2) = 0, \\
Y_2(y_3) &= 0 && \text{since } Y_{23}(y_3) = Y_{13}(y_3) = 0, \\
Y_2(y_4) &= -(-Y_{23}(y_4))\sigma(-Y_{23})^{-1}\sigma(Y_{34})Y_{34}(y_2)^{-1}Y_{13}(y_2) = -yb^{-1},
\end{aligned}$$

and so

$$Y_2 = (-1, 1, 0, -yb^{-1}, 0).$$

Similarly by Lemma 3.7, we have

$$\begin{aligned}
Z(y_1) &= 0 && \text{since } Y_{13}(y_1) = Y_{12}(y_1) = 0, \\
Z(y_2) &= Y_{13}(y_2) = 1 && \text{since } Y_{12}(y_2) = 0, \\
Z(y_3) &= Y_{12}(y_3) = 1 && \text{since } Y_{13}(y_3) = 0, \\
Z(y_4) &= -Y_{13}(y_4)\sigma(Y_{13})^{-1}\sigma(Y_{14})Y_{14}(y_3)^{-1}Y_{12}(y_3) = b^{-1}za^{-1},
\end{aligned}$$

and so

$$Z = (0, 1, 1, b^{-1}za^{-1}, 0).$$

We can see that $Y_1^0 = \{y_2, p\}$ and $Y_2^0 = \{y_3, p\}$, thus Y_1 and Y_2 form a modular pair. As $Y_1(y_1) = 1$, $Y_2(y_1) = -1$ and $Z^0 = \{y_1, p\}$, thus Z should eliminate y_1 between Y_1 and Y_2 . Then

$$\begin{aligned}
Y_1(y_2) + Y_2(y_2) - Z(y_2) &= 0 + 1 - 1 = 0 \in N_G, \\
Y_1(y_3) + Y_2(y_3) - Z(y_3) &= 1 + 0 - 1 = 0 \in N_G,
\end{aligned}$$

but

$$Y_1(y_4) + Y_2(y_4) - Z(y_4) = xa^{-1} - yb^{-1} - b^{-1}za^{-1} = a^{-1}x - yb^{-1} - a^{-1}zb^{-1} = a^{-1}(xb - ay - z)b^{-1} \notin N_G,$$

by Pathetic Cancellation. We got a contradiction.

So σ is not a localization of \mathcal{M} . □

There is also an example of a right T -matroid and a left T^\times -equivariant function defined analogously.

This proves the necessity of Pathetic Cancellation for extending Crapo and Las Vergnas' results. We will prove the sufficiency in the next section.

5. CHARACTERIZATION OF LOCALIZATION FOR WEAK T -MATROID

Our main theorem (Theorem 5.1) in this section proves the converse of Theorem 4.3.

Theorem 5.1. *Let T be a skew tract satisfying Pathetic Cancellation, let \mathcal{M} be a weak left T -matroid on E , and let*

$$\sigma : \mathcal{C}^*(\mathcal{M}) \rightarrow T$$

be a right T^\times -equivariant function.

Then the following statements are equivalent.

- (1) σ is a weak localization of \mathcal{M} .
- (2) σ defines a weak single-element extension of every rank 2 contraction of \mathcal{M} .
- (3) σ defines a weak single-element extension of every rank 2 minor of \mathcal{M} on three elements.

The statement also holds if \mathcal{M} is a weak right T -matroid and σ is left T^\times -equivariant.

Before showing the main theorem, we will first introduce some useful lemmas.

Lemma 5.2. *Let \mathcal{M} be a (weak or strong) left T -matroid of rank d on E , let $[\cdot]$ be left quasi-Plücker coordinates of \mathcal{M} , and let $\sigma : \mathcal{C}^*(\mathcal{M}) \rightarrow T$ be a right T^\times -equivariant function. Let cl be the closure operator of $\underline{\mathcal{M}}$. Then for any $F \subseteq E$ independent in \mathcal{M} with $|F| = d - 1$, $Y \in \mathcal{C}^*(\mathcal{M})$, $y \in E$ such that $\underline{Y} = E \setminus \text{cl}(F)$ and $y \in \underline{Y}$, we have*

$$Y(y) \cdot \sigma(Y)^{-1}$$

is independent of the choice of Y .

Proof. Let F be an independent subset of E with $|F| = d - 1$. Then there exists a unique projective T -cocircuit D such that $\underline{Y} = E \setminus \text{cl}(F)$ for any T -cocircuit $Y \in D$.

Let $Y_1, Y_2 \in D$. Then by definition, there exists $\alpha \in T^\times$ such that $Y_1 = Y_2 \cdot \alpha$. Let $y \in \underline{Y}_1 = \underline{Y}_2$. We have

$$\begin{aligned} Y_2(y) \cdot \sigma(Y_2)^{-1} &= Y_2(y) \cdot \alpha \cdot \alpha^{-1} \cdot \sigma(Y_2)^{-1} \\ &= (Y_2(y) \cdot \alpha) \cdot (\sigma(Y_2) \cdot \alpha)^{-1} \\ &= (Y_2(y) \cdot \alpha) \cdot \sigma(Y_2 \cdot \alpha)^{-1} \\ &= Y_1(y) \cdot \sigma(Y_1)^{-1}. \end{aligned}$$

So $Y(y) \cdot \sigma(Y)^{-1}$ is independent of the choice of $Y \in D$. \square

So for a weak left T -matroid \mathcal{M} of rank d with bases \mathcal{B} and left quasi-Plücker coordinates $[\cdot]$ and a right T^\times -equivariant function $\sigma : \mathcal{C}^*(\mathcal{M}) \rightarrow T$, we can define a collection $\tilde{\mathcal{B}}$ of subsets of $E \cup p$ by

$$\tilde{\mathcal{B}} = \mathcal{B} \cup \{Fp \subseteq E \cup p \mid |F| = d - 1, E \setminus \text{cl}(F) = \underline{Y} \text{ and } \sigma(Y) \neq 0 \text{ for some } Y \in \mathcal{C}^*(\mathcal{M})\},$$

where cl is the closure operator of $\underline{\mathcal{M}}$. It is trivial to see that every set of $\tilde{\mathcal{B}}$ has the same size. Then we define the collection $A_{\tilde{\mathcal{B}}}$ of adjacent sets by $A_{\tilde{\mathcal{B}}} := \{(B, B') \in \tilde{\mathcal{B}} \times \tilde{\mathcal{B}} \mid |B \setminus B'| = 1\} \subseteq T^{E \cup p}$ and then define left T -coordinates $[\cdot]_p : A_{\tilde{\mathcal{B}}} \rightarrow T$ by

$$[Fs, Ft]_p = \begin{cases} [Fs, Ft] & \text{if } p \notin Fst, \\ \frac{\sigma(Y) \cdot Y(t)^{-1}}{Y(s) \cdot \sigma(Y)^{-1}} & \text{if } p = s \text{ and } Y \in \mathcal{C}^*(\mathcal{M}) \text{ with } \underline{Y} = E \setminus \text{cl}(F), \\ \frac{[Gsg, Gtg]}{[Gsg, Gtg]} & \text{if } p = t \text{ and } Y \in \mathcal{C}^*(\mathcal{M}) \text{ with } \underline{Y} = E \setminus \text{cl}(F), \\ [Gsg, Gtg] & \text{if } p \in F, G = F \setminus \{p\}, Gst \notin \mathcal{B} \text{ and } Gsg, Gtg \in \mathcal{B} \\ & \text{for some } g \in E, \\ \frac{-\overline{Y_t(s) \cdot \sigma(Y_t)^{-1} \cdot \sigma(Y_s) \cdot Y_s(t)^{-1}}}{-\overline{Y_t(s) \cdot \sigma(Y_t)^{-1} \cdot \sigma(Y_s) \cdot Y_s(t)^{-1}}} & \text{if } p \in F, G = F \setminus \{p\}, Gst \in \mathcal{B}, Y_i \in \mathcal{C}^*(\mathcal{M}) \text{ with} \\ & \underline{Y}_i = E \setminus \text{cl}(Gi) \text{ for } i \in \{s, t\}. \end{cases}$$

Lemma 5.3. $[\cdot]_p$ satisfies (P3) and (P5) in weak left quasi-Plücker coordinates axioms if and only if σ is a localization of \mathcal{M} .

Proof. (\Leftarrow): This is proved by Proposition 3.6.

(\Rightarrow): By definition, $[\cdot]_p$ satisfies (P1), (P2) and (P4) in weak left quasi-Plücker coordinates axioms. Then if $[\cdot]_p$ satisfies (P3) and (P5) in weak left quasi-Plücker coordinates axioms, $[\cdot]$ are weak left quasi-Plücker coordinates of $\underline{\mathcal{M}}$. It is easy to check that $[\cdot]_p$ satisfies the Dual Pivoting Property with $\mathcal{C}^*(\mathcal{M})$.

So σ is a localization. \square

Now we would like to introduce a lemma extending one direction of Lemma 4.4 to weak left T -matroids.

Lemma 5.4. Let \mathcal{M} be a (weak or strong) left T -matroid on E and let $\sigma : \mathcal{C}^*(\mathcal{M}) \rightarrow T$ be a localization of \mathcal{M} . Let (Y_1, Y_2) be a modular pair of T -cocircuits of \mathcal{M} with $Y_1(e) = -Y_2(e) \neq 0$ for some $e \in E$. Let $Y_3 \in \mathcal{C}^*(\mathcal{M})$ eliminate e between Y_1 and Y_2 . Then $\sigma(Y_1) + \sigma(Y_2) - \sigma(Y_3) \in N_G$.

Proof. We denote $(Y_i, \sigma(Y_i))$ by \tilde{Y}_i for $i \in \{1, 2\}$. As (Y_1, Y_2) is a modular pair of T -cocircuits of \mathcal{M} with $Y_1(e) = -Y_2(e) \neq 0$, then \tilde{Y}_1 and \tilde{Y}_2 form a modular pair of T -cocircuits of $\tilde{\mathcal{M}}$ with $\tilde{Y}_1(e) = -\tilde{Y}_2(e) \neq 0$. Let $Z \in \mathcal{C}^*(\tilde{\mathcal{M}})$ eliminate e between \tilde{Y}_1 and \tilde{Y}_2 . Thus $Z(e) = 0$ and $\tilde{Y}_1(f) + \tilde{Y}_2(f) - Z(f) \in N_G$ for all $f \in E \cup p$. Then $\sigma(Y_1) + \sigma(Y_2) - Z(p) \in N_G$.

We would like to show that $Z = (Y_3, \sigma(Y_3))$, from which it follows that $\sigma(Y_1) + \sigma(Y_2) - \sigma(Y_3) \in N_G$.

By Proposition 3.9, we know that

$$\begin{aligned} \mathcal{C}^*(\tilde{\mathcal{M}}) &= \{(W, \sigma(W)) : W \in \mathcal{C}^*(\mathcal{M})\} \cup \\ &\quad \{\text{Mod}(W_1, W_2, p) : W_1, W_2 \in \mathcal{C}^*(\mathcal{M}), (W_1, W_2) \text{ is a modular pair of } T\text{-cocircuits,} \\ &\quad \text{and } \sigma(W_1) = -\sigma(W_2) \neq 0\}. \end{aligned}$$

We first claim that $Z \notin \{\text{Mod}(Y_1, Y_2, p) : Y_1, Y_2 \in \mathcal{C}^*(\mathcal{M}), (Y_1, Y_2) \text{ is a modular pair of } T\text{-cocircuits, and } \sigma(Y_1) = -\sigma(Y_2) \neq 0\}$. Otherwise, there exist (Z_1, Z_2) a modular pair of T -cocircuits of \mathcal{M} such that $\sigma(Z_1) = -\sigma(Z_2) \neq 0$ and $Z = \text{Mod}(Z_1, Z_2, p)$. By Corollary 3.10, $\underline{Z} = \underline{Z}_1 \cup \underline{Z}_2$. As Z eliminates e between \widetilde{Y}_1 and \widetilde{Y}_2 , then $\underline{Z} \subseteq (\widetilde{Y}_1 \cup \widetilde{Y}_2) \setminus \{e\}$. As $Z(p) = 0$, then $\underline{Z} \subseteq (\underline{Y}_1 \cup \underline{Y}_2) \setminus \{e\} \subset \underline{Y}_1 \cup \underline{Y}_2$. So $\underline{Z}_1, \underline{Z}_2 \subset \underline{Z}_1 \cup \underline{Z}_2 \subset \underline{Y}_1 \cup \underline{Y}_2$. As (Y_1, Y_2) is a modular pair of T -cocircuits of \mathcal{M} , by Definition 2.10, the height of $\underline{Y}_1 \cup \underline{Y}_2$ is 2 in the lattice $U(\mathcal{C}^*(\mathcal{M}))$. We got a contradiction. So our claim holds.

Then from our claim, we have that $Z \in \{(Y, \sigma(Y)) : Y \in \mathcal{C}^*(\mathcal{M})\}$. Let $x \in \underline{Y}_1 \setminus \underline{Y}_2$. Then there exists $Z' \in \mathcal{C}^*(\mathcal{M})$ such that $Z = (Z', \sigma(Z'))$. As Z eliminates e between \widetilde{Y}_1 and \widetilde{Y}_2 , then $\underline{Z} \subseteq (\widetilde{Y}_1 \cup \widetilde{Y}_2) \setminus \{e\}$ and $Z(x) = Y_1(x)$. Thus $\underline{Z}' \subseteq (\underline{Y}_1 \cup \underline{Y}_2) \setminus \{e\}$ and $Z'(x) = Y_1(x)$.

As Y_3 eliminates e between Y_1 and Y_2 , then $\underline{Y}_3 \subseteq (\underline{Y}_1 \cup \underline{Y}_2) \setminus \{e\}$ and $Y_3(x) = Y_1(x)$.

Suppose by way of contradiction that $Z' \neq Y_3$. As $\underline{Z}' \subseteq (\underline{Y}_1 \cup \underline{Y}_2) \setminus \{e\}$ and $\underline{Y}_3 \subseteq (\underline{Y}_1 \cup \underline{Y}_2) \setminus \{e\}$, then $\underline{Z}' \cup \underline{Y}_3 \subseteq (\underline{Y}_1 \cup \underline{Y}_2) \setminus \{e\} \subset \underline{Y}_1 \cup \underline{Y}_2$. As (Y_1, Y_2) is a modular pair of T -cocircuits of \mathcal{M} , by Definition 2.10, the height of $\underline{Y}_1 \cup \underline{Y}_2$ is 2 in the lattice $U(\mathcal{C}^*(\mathcal{M}))$, contradicting that

$$\underline{Z}', \underline{Y}_3 \subset \underline{Z}' \cup \underline{Y}_3 \subset \underline{Y}_1 \cup \underline{Y}_2.$$

So $Z' = Y_3$, and then $Z = (Y_3, \sigma(Y_3))$.

So $\sigma(Y_1) + \sigma(Y_2) - \sigma(Y_3) \in N_G$. □

The statement also hold if \mathcal{M} is a (weak or strong) right T -matroid.

Following is a useful lemma showing that $\sigma \cdot \alpha$ is a localization if σ is, for all $\alpha \in T^\times$.

Lemma 5.5. *Let \mathcal{M} be a (weak or strong) left T -matroid on E , let $\sigma : \mathcal{C}^*(\mathcal{M}) \rightarrow T$ be a localization, and let $\widetilde{\mathcal{M}}$ be the extension of \mathcal{M} by an element p determined by σ . Let $\alpha \in T^\times$. Then $\alpha \cdot \sigma$ is also a localization of \mathcal{M} and the corresponding extension is the left T -matroid $\widetilde{\mathcal{M}}^\rho$ arising from $\widetilde{\mathcal{M}}$ by right rescaling, where $\rho : E \cup p \rightarrow T^\times$ is a function defined by*

$$\rho(e) = \begin{cases} 1 & \text{if } e \in E, \\ \alpha & \text{if } e = p. \end{cases}$$

Proof. First we consider the left T -matroid $\widetilde{\mathcal{M}}^\rho$ arising from $\widetilde{\mathcal{M}}$ by right rescaling. By Lemma 2.25, we know that $\mathcal{C}^*(\widetilde{\mathcal{M}}^\rho) = \rho \cdot \mathcal{C}^*(\widetilde{\mathcal{M}})$. By definition of ρ , we have

$$\begin{aligned} \mathcal{C}^*(\widetilde{\mathcal{M}}^\rho \setminus p) &= \mathcal{C}^*(\widetilde{\mathcal{M}}^\rho) / p \\ &= (\rho \cdot \mathcal{C}^*(\widetilde{\mathcal{M}})) / p \\ &= \text{MinSupp}(\{(\rho \cdot Y) \setminus p \mid Y \in \mathcal{C}^*(\widetilde{\mathcal{M}})\}) \\ &= \text{MinSupp}(\{Y \setminus p \mid Y \in \mathcal{C}^*(\widetilde{\mathcal{M}})\}) \\ &= \mathcal{C}^*(\widetilde{\mathcal{M}}) / p \\ &= \mathcal{C}^*(\widetilde{\mathcal{M}} \setminus p) \\ &= \mathcal{C}^*(\mathcal{M}). \end{aligned}$$

So by definition, $\widetilde{\mathcal{M}}^\rho$ is also a weak extension of \mathcal{M} by the same element p .

Now we would like to show that $\alpha \cdot \sigma$ is the localization corresponding to $\widetilde{\mathcal{M}}^\rho$. Let $Y \in \mathcal{C}^*(\mathcal{M})$. By definition, we know that $(Y, \sigma(Y)) \in \mathcal{C}^*(\widetilde{\mathcal{M}})$. Then

$$\mathcal{C}^*(\widetilde{\mathcal{M}}^\rho) \ni \rho \cdot (Y, \sigma(Y)) = (Y, \alpha \cdot \sigma(Y)).$$

So by Proposition 3.2, $\alpha \cdot \sigma$ is the localization corresponding to $\widetilde{\mathcal{M}}^\rho$. □

Now we would like to prove Theorem 5.1. But the proof will be a very long calculation. So we will first introduce a lemma which shows a general version of the direction (1) \Rightarrow (2).

Lemma 5.6. *Let \mathcal{M} be a (weak or strong) left T -matroid on E and let $\sigma : \mathcal{C}^*(\mathcal{M}) \rightarrow T$ be a localization of \mathcal{M} . Then σ defines a single-element extension of every contraction of \mathcal{M} .*

Proof. Let $\widetilde{\mathcal{M}}$ be the extension of \mathcal{M} by an element p determined by σ and let $E_0 \subseteq E$. We would like to consider the contraction \mathcal{M}/E_0 of \mathcal{M} . By definition, we know that

$$\mathcal{C}^*((\widetilde{\mathcal{M}}/E_0)\setminus p) = \mathcal{C}^*((\widetilde{\mathcal{M}}\setminus p)/E_0) = \mathcal{C}^*(\mathcal{M}/E_0).$$

So $\widetilde{\mathcal{M}}/E_0$ is an extension of \mathcal{M}/E_0 by the element p .

Let $\sigma' : \mathcal{C}^*(\mathcal{M}/E_0) \rightarrow T$ be the function induced by σ . We would like to show that σ' is the localization of \mathcal{M}/E_0 corresponding to $\widetilde{\mathcal{M}}/E_0$. It suffices to show that

$$\begin{aligned} \mathcal{C}^*(\widetilde{\mathcal{M}}/E_0) &= \{(Z, \sigma'(Z)) : Z \in \mathcal{C}^*(\mathcal{M}/E_0)\} \cup \\ &\quad \{\text{Mod}(Z_1, Z_2, p) : (Z_1, Z_2) \text{ is a modular pair of } T\text{-cocircuits of} \\ &\quad \mathcal{M}/E_0 \text{ and } \sigma(Z_1) = -\sigma(Z_2) \neq 0\}. \end{aligned}$$

By Theorem 2.20 and Proposition 3.9,

$$\begin{aligned} \mathcal{C}^*(\widetilde{\mathcal{M}}/E_0) &= \mathcal{C}^*(\widetilde{\mathcal{M}})\setminus E_0 \\ &= \{Y\setminus E_0 : Y \in \mathcal{C}^*(\widetilde{\mathcal{M}}), \underline{Y} \cap E_0 = \emptyset\} \\ &= \{(Y, \sigma(Y))\setminus E_0 : Y \in \mathcal{C}^*(\mathcal{M}), \underline{Y} \cap E_0 = \emptyset\} \cup \{\text{Mod}(Y_1, Y_2, p)\setminus E_0 : (Y_1, Y_2) \\ &\quad \text{is a modular pair of } T\text{-cocircuits of } \mathcal{M}, \sigma(Y_1) = -\sigma(Y_2) \neq 0 \text{ and} \\ &\quad \underline{\text{Mod}}(Y_1, Y_2, p) \cap E_0 = \emptyset\}. \\ &= \{(Y\setminus E_0, \sigma(Y)) : Y \in \mathcal{C}^*(\mathcal{M}), \underline{Y} \cap E_0 = \emptyset\} \cup \{\text{Mod}(Y_1, Y_2, p)\setminus E_0 : (Y_1, Y_2) \\ &\quad \text{is a modular pair of } T\text{-cocircuits of } \mathcal{M}, \sigma(Y_1) = -\sigma(Y_2) \neq 0 \text{ and} \\ &\quad (\underline{Y}_1 \cup \underline{Y}_2) \cap E_0 = \emptyset\}. \\ &= \{(Z, \sigma'(Z)) : Z \in \mathcal{C}^*(\mathcal{M}/E_0)\} \cup \{\text{Mod}(Z_1, Z_2, p) : (Z_1, Z_2) \text{ is a modular} \\ &\quad \text{pair of } T\text{-cocircuits of } \mathcal{M}/E_0 \text{ and } \sigma(Z_1) = -\sigma(Z_2) \neq 0\}. \end{aligned}$$

□

The statement also holds if \mathcal{M} is a (weak or strong) right T -matroid.

Now we will introduce a lemma which shows a general version of the direction (2) \Rightarrow (3) in Theorem 5.1.

Lemma 5.7. *Let \mathcal{M} be a (weak or strong) left T -matroid on E and let $\sigma : \mathcal{C}^*(\mathcal{M}) \rightarrow T$ be a localization of \mathcal{M} . Then σ defines a single-element extension of every deletion of \mathcal{M} .*

Proof. Let $\widetilde{\mathcal{M}}$ be the extension of \mathcal{M} by an element p determined by σ and let $E_0 \subseteq E$. We will prove that σ defines a single-element extension of $\mathcal{M}\setminus E_0$ when $|E_0| = 1$ and the claim of the lemma follows by induction on the size of E_0 . Let $E_0 = \{e_0\}$.

By definition, we know that

$$\mathcal{C}^*((\widetilde{\mathcal{M}}\setminus e_0)\setminus p) = \mathcal{C}^*((\widetilde{\mathcal{M}}\setminus p)\setminus e_0) = \mathcal{C}^*(\mathcal{M}\setminus e_0).$$

So $\widetilde{\mathcal{M}}\setminus e_0$ is an extension of $\mathcal{M}\setminus e_0$ by the element p .

Let $\sigma' : \mathcal{C}^*(\mathcal{M}\setminus e_0) \rightarrow T$ be the function induced by σ . We would like to show that σ' is the localization of $\mathcal{M}\setminus e_0$ corresponding to $\widetilde{\mathcal{M}}\setminus e_0$.

Let $Z \in \mathcal{C}^*(\mathcal{M}\setminus e_0)$. Then by definition, there exists $Y \in \mathcal{C}^*(\mathcal{M})$ such that $Z = Y\setminus e_0$. By Proposition 3.2, $\widetilde{Y} := (Y, \sigma(Y)) \in \mathcal{C}^*(\widetilde{\mathcal{M}})$. We claim that $\widetilde{Y}\setminus e_0 \in \mathcal{C}^*(\widetilde{\mathcal{M}}\setminus e_0)$. Otherwise, there exists $W \in \mathcal{C}^*(\widetilde{\mathcal{M}})$ such that $\underline{W}\setminus e_0 \subset \underline{\widetilde{Y}}\setminus e_0$. Then either $\underline{W}\setminus\{e_0, p\} \subset \underline{\widetilde{Y}}\setminus\{e_0, p\} = \underline{Z}$ or $\underline{W}\setminus\{e_0, p\} = \underline{\widetilde{Y}}\setminus\{e_0, p\}$ and $W(p) = 0$. The first case contradicts the definition of Z .

Now we consider the second case. As $\underline{W}\setminus\{e_0, p\} = \underline{\widetilde{Y}}\setminus\{e_0, p\}$, then by comparability there exists $\alpha \in T^\times$ such that $\underline{W}\setminus\{e_0, p\} = (\underline{\widetilde{Y}}\setminus\{e_0, p\}) \cdot \alpha$. Without loss of generality, we assume that $\alpha = -1$. As $W(p) = 0$,

then $W(e_0) \neq 0$ and $\tilde{Y}(e_0) = 0$. So $\text{rank}_{\tilde{\mathcal{M}}}(W^0 \cap \tilde{Y}^0) = \text{rank}(\tilde{\mathcal{M}}) - 2$ and so W and \tilde{Y} form a modular pair of T -cocircuits in $\tilde{\mathcal{M}}$. Let $e_1 \in \underline{W} \cap \underline{\tilde{Y}} = \underline{W} \setminus \{e_0, p\}$. By Modular Elimination, there exists $V \in \mathcal{C}^*(\tilde{\mathcal{M}})$ such that $V(e_1) = 0$ and $W(f) + \tilde{Y}(f) - V(f) \in N_G$. Then $\underline{V} \subseteq (\underline{W} \cup \underline{\tilde{Y}}) \setminus e_1 = (\underline{Z} \cup \{e_0, p\}) \setminus e_1$. So $\underline{V} \setminus \{e_0, p\} \subseteq \underline{Z} \setminus e_1 \subseteq \underline{Z}$, contradicting the definition of Z .

So our claim is true, that is $\tilde{Y} \setminus e_0 \in \mathcal{C}^*(\tilde{\mathcal{M}} \setminus e_0)$. So

$$(Z, \sigma'(Z)) = (Y \setminus e_0, \sigma(Y)) = \tilde{Y} \setminus e_0 \in \mathcal{C}^*(\tilde{\mathcal{M}} \setminus e_0).$$

So σ' is the localization of $\mathcal{M} \setminus e_0$ corresponding to $\tilde{\mathcal{M}} \setminus e_0$, and so σ defines a single-element extension of $\mathcal{M} \setminus e_0$. \square

The statement also holds if \mathcal{M} is a (weak or strong) right T -matroid.

Then we will introduce a lemma which shows a general version of the direction (3) \Rightarrow (2) in Theorem 5.1.

Lemma 5.8. *Let \mathcal{M} be a T -matroid on E of rank 2 and let $\sigma : \mathcal{C}^*(\mathcal{M}) \rightarrow T$ be a function. If σ defines a single-element extension of every minor of \mathcal{M} on three elements, then σ is a localization of \mathcal{M} .*

Proof. Let cl be the closure operator of $\underline{\mathcal{M}}$. Let \mathcal{B} be set of bases of \mathcal{M} and let $[\cdot] : A_{\mathcal{B}} \rightarrow T$ be left quasi-Plücker coordinates of \mathcal{M} . We define a collection $\tilde{\mathcal{B}}$ of subsets of $E \cup p$ and the left T -coordinates $[\cdot]_p : A_{\tilde{\mathcal{B}}} \rightarrow T$ as in Lemma 5.3. Then

$$\tilde{\mathcal{B}} := \mathcal{B} \cup \{\{e, p\} \mid e \in E, E \setminus \text{cl}(\{e\}) = \underline{Y} \text{ and } \sigma(Y) \neq 0 \text{ for some } Y \in \mathcal{C}^*(\mathcal{M})\}$$

and

$$[\{e, s\}, \{e, t\}]_p = \begin{cases} [\{e, s\}, \{e, t\}] & \text{if } p \notin \{e, s, t\}, \\ \frac{\sigma(Y) \cdot Y(t)^{-1}}{\sigma(Y) \cdot Y(t)^{-1}} & \text{if } p = s \text{ and } Y \in \mathcal{C}^*(\mathcal{M}) \text{ with } \underline{Y} = E \setminus \text{cl}(\{e\}), \\ \frac{\sigma(Y) \cdot Y(t)^{-1}}{\sigma(Y) \cdot Y(t)^{-1}} & \text{if } p = t \text{ and } Y \in \mathcal{C}^*(\mathcal{M}) \text{ with } \underline{Y} = E \setminus \text{cl}(\{e\}), \\ [\{s, g\}, \{t, g\}] & \text{if } p = e, \{s, t\} \notin \mathcal{B} \text{ and } \{s, g\}, \{t, g\} \in \mathcal{B} \\ & \text{for some } g \in E, \\ \frac{\sigma(Y_t) \cdot Y_t^{-1} \cdot \sigma(Y_s) \cdot Y_s(t)^{-1}}{\sigma(Y_t) \cdot Y_t^{-1} \cdot \sigma(Y_s) \cdot Y_s(t)^{-1}} & \text{if } p = e, \{s, t\} \in \mathcal{B}, Y_i \in \mathcal{C}^*(\mathcal{M}) \text{ with} \\ & \underline{Y}_i = E \setminus \text{cl}(\{i\}) \text{ for } i \in \{s, t\}. \end{cases} \quad (3)$$

Now we just need to show that $[\cdot]_p$ satisfies (P3) and (P5) in weak left quasi-Plücker coordinates axioms. So we need to show that

(a) for any $e, x_1, x_2, x_3 \in E \cup p$ with $\{e, x_i\} \in \tilde{\mathcal{B}}$ for all $i \in \{1, 2, 3\}$, we have

$$[\{e, x_1\}, \{e, x_2\}]_p \cdot [\{e, x_2\}, \{e, x_3\}]_p \cdot [\{e, x_3\}, \{e, x_1\}]_p = 1, \quad (4)$$

(b) for any $y_1, y_2, y_3, y_4 \in E \cup p$ with $\{y_i, y_j\} \in \tilde{\mathcal{B}}$ for all $i, j \in \{1, 2, 3, 4\}$ and $i \neq j$, we have

$$-1 + [\{y_2, y_4\}, \{y_1, y_2\}]_p \cdot [\{y_1, y_3\}, \{y_3, y_4\}]_p + [\{y_1, y_4\}, \{y_1, y_2\}]_p \cdot [\{y_2, y_3\}, \{y_3, y_4\}]_p \in N_G. \quad (5)$$

First, we prove Equation (4). If $p \notin \{e, x_1, x_2, x_3\}$, then from Formula (3) we know that $[\cdot]$ and $[\cdot]_p$ coincide on each pair of the bases in (4). So Equation (4) holds because $[\cdot]$ satisfies (P3). If $p \in \{e, x_1, x_2, x_3\}$, then we consider a minor \mathcal{M}_3 of \mathcal{M} on $\{e, x_1, x_2, x_3\} \setminus p$. By assumption, σ defines a single-element extension of \mathcal{M}_3 . So Equation (4) holds.

Now, we prove the inclusion (5). If $p \notin \{y_1, y_2, y_3, y_4\}$, then from Formula (3) we know that $[\cdot]$ and $[\cdot]_p$ coincide on each pair of the bases in (5). So the inclusion (5) holds because $[\cdot]$ satisfies (P5). If $p \in \{y_1, y_2, y_3, y_4\}$. Now we consider a minor \mathcal{M}'_3 of \mathcal{M} on $\{y_1, y_2, y_3, y_4\} \setminus p$. By assumption, σ defines a single-element extension of \mathcal{M}'_3 . So the inclusion (5) holds. \square

Finally, we will prove the main theorem (Theorem 5.1) in this section.

Proof of Theorem 5.1. (1) \Rightarrow (2): This is proved by Lemma 5.6.

(2) \Rightarrow (3): This is proved by Lemma 5.7.

(3) \Rightarrow (2): This is proved by Lemma 5.8.

(2) \Rightarrow (1): Let $d = \text{rank}(\mathcal{M})$. Let r be the rank function of $\underline{\mathcal{M}}$ and let cl be closure operator of $\underline{\mathcal{M}}$. Let \mathcal{B} be set of bases of \mathcal{M} and let $[\cdot] : A_{\mathcal{B}} \rightarrow T$ be weak left quasi-Plücker coordinates of \mathcal{M} .

We define a collection $\tilde{\mathcal{B}}$ of subsets of $E \cup p$ by

$$\tilde{\mathcal{B}} = \mathcal{B} \cup \{Fp \subseteq E \cup p \mid |F| = d-1, E \setminus \text{cl}(F) = \underline{Y} \text{ and } \sigma(Y) \neq 0 \text{ for some } Y \in \mathcal{C}^*(\mathcal{M})\},$$

as in Lemma 5.3. Now we consider the left T -coordinates $[\cdot]_p : A_{\tilde{\mathcal{B}}} \rightarrow T$ defined in Lemma 5.3:

$$[Fs, Ft]_p = \begin{cases} [Fs, Ft] & \text{if } p \notin Fst, \\ \frac{\sigma(Y) \cdot Y(t)^{-1}}{\sigma(Y) \cdot Y(t)^{-1}} & \text{if } p = s \text{ and } Y \in \mathcal{C}^*(\mathcal{M}) \text{ with } \underline{Y} = E \setminus \text{cl}(F), \\ \frac{Y(s) \cdot \sigma(Y)^{-1}}{Y(s) \cdot \sigma(Y)^{-1}} & \text{if } p = t \text{ and } Y \in \mathcal{C}^*(\mathcal{M}) \text{ with } \underline{Y} = E \setminus \text{cl}(F), \\ [Gsg, Gtg] & \text{if } p \in F, G = F \setminus p, Gst \notin \mathcal{B} \text{ and } Gsg, Gtg \in \mathcal{B} \\ & \text{for some } g \in E, \\ \frac{-\overline{Y_t(s) \cdot \sigma(Y_t)^{-1} \cdot \sigma(Y_s) \cdot Y_s(t)^{-1}}}{-\overline{Y_t(s) \cdot \sigma(Y_t)^{-1} \cdot \sigma(Y_s) \cdot Y_s(t)^{-1}}} & \text{if } p \in F, G = F \setminus p, Gst \in \mathcal{B}, Y_i \in \mathcal{C}^*(\mathcal{M}) \text{ with} \\ & \underline{Y_i} = E \setminus \text{cl}(Gi) \text{ for } i \in \{s, t\}. \end{cases} \quad (6)$$

By Lemma 5.3, we just need to show that $[\cdot]_p$ satisfies (P3) and (P5) in weak left quasi-Plücker coordinates axioms. So we need to show

(A) for any $x_1, x_2, x_3 \in E \cup p$ and $H \subseteq E \cup p$ with $Hx_1, Hx_2, Hx_3 \in \tilde{\mathcal{B}}$, we have

$$[Hx_1, Hx_2]_p \cdot [Hx_2, Hx_3]_p \cdot [Hx_3, Hx_1]_p = 1, \quad (7)$$

(B) for any $y_1, y_2, y_3, y_4 \in E \cup p$ and $F \subseteq E \cup p$ with $Fy_i y_j \in \tilde{\mathcal{B}}$ for all $i, j \in \{1, 2, 3, 4\}$ and $i \neq j$, we have

$$-1 + [Fy_2 y_4, Fy_1 y_2]_p \cdot [Fy_1 y_3, Fy_3 y_4]_p + [Fy_1 y_4, Fy_1 y_2]_p \cdot [Fy_2 y_3, Fy_3 y_4]_p \in N_G. \quad (8)$$

First, we will prove Equation (7).

If $p \notin H \cup \{x_1, x_2, x_3\}$, then we know that $[\cdot]$ and $[\cdot]_p$ coincide on each pair of the bases in (7). So Equation (7) holds because $[\cdot]$ satisfies (P3).

If $p \in \{x_1, x_2, x_3\}$, without loss of generality we assume $p = x_1$. Then there exists $Y \in \mathcal{C}^*(\mathcal{M})$ with $\underline{Y} = E \setminus \text{cl}(H)$ and $\sigma(Y) \neq 0$. Then $x_2, x_3 \in \underline{Y}$. By Formula (6), we get that

$$\begin{aligned} [Hx_1, Hx_2]_p \cdot [Hx_2, Hx_3]_p \cdot [Hx_3, Hx_1]_p &= [Hp, Hx_2]_p \cdot [Hx_2, Hx_3]_p \cdot [Hx_3, Hp]_p \\ &= \frac{\sigma(Y)Y(x_2)^{-1}}{\sigma(Y)Y(x_2)^{-1}} \cdot \frac{\overline{Y(x_2)Y(x_3)^{-1}}}{\overline{Y(x_2)Y(x_3)^{-1}}} \cdot \frac{\overline{Y(x_3)\sigma(Y)^{-1}}}{\overline{Y(x_3)\sigma(Y)^{-1}}} \\ &= 1. \end{aligned}$$

If $p \in H$, then let $G = H \setminus \{p\}$. As $r(G) = d-2$, then let $\mathcal{M}' = \mathcal{M}/G$ and $[\cdot]' = [\cdot]/G$. Then \mathcal{M}' is a rank 2 contraction of \mathcal{M} and $[\cdot]'$ are weak left quasi-Plücker coordinates of \mathcal{M}' . Let $\sigma' : \mathcal{C}^*(\mathcal{M}') \rightarrow T$ be the function induced by σ . As σ defines a single-element extension of every rank 2 contraction of \mathcal{M} , then σ' is a localization of \mathcal{M}' and we call the corresponding extension $\tilde{\mathcal{M}}'$. So by Lemma 3.4, the set of bases of $\tilde{\mathcal{M}}'$ is

$$\tilde{\mathcal{B}}' = \mathcal{B}(\mathcal{M}') \cup \{\{e, p\} \subseteq (E \setminus G) \cup p \mid (E \setminus G) \setminus \text{cl}_{\mathcal{M}'}(\{e\}) = \underline{X} \text{ and } \sigma'(X) \neq 0 \text{ for some } X \in \mathcal{C}^*(\mathcal{M}')\}.$$

By Proposition 3.6, the corresponding weak left quasi-Plücker coordinates $[\cdot]'_p : A_{\tilde{\mathcal{B}}'} \rightarrow T$ are given by

$$\{\{e, s\}, \{e, t\}\}'_p$$

$$= \begin{cases} \frac{[\{e, s\}, \{e, t\}]'}{\sigma'(X) \cdot X(t)^{-1}} & \text{if } p \notin \{e, s, t\}, \\ \frac{X(s) \cdot \sigma'(X)^{-1}}{[\{s, g\}, \{t, g\}]'} & \text{if } p = s \text{ and } X \in \mathcal{C}^*(\mathcal{M}') \text{ with } \underline{X} = (E \setminus G) \setminus \text{cl}_{\mathcal{M}'}(\{e\}), \\ \frac{[\{s, g\}, \{t, g\}]'}{-\overline{X_t(s) \cdot \sigma'(X_t)^{-1} \cdot \sigma'(X_s) \cdot X_s(t)^{-1}}} & \text{if } p = t \text{ and } X \in \mathcal{C}^*(\mathcal{M}') \text{ with } \underline{X} = (E \setminus G) \setminus \text{cl}_{\mathcal{M}'}(\{e\}), \\ & \text{if } p = e, \{s, t\} \notin \mathcal{B}(\mathcal{M}') \text{ and } \{s, g\}, \{t, g\} \in \mathcal{B}(\mathcal{M}') \\ & \text{for some } g \in E \setminus G, \\ & \text{if } p = e, \{s, t\} \in \mathcal{B}(\mathcal{M}'), X_i \in \mathcal{C}^*(\mathcal{M}') \text{ with} \\ & \underline{X}_i = (E \setminus G) \setminus \text{cl}_{\mathcal{M}'}(\{i\}) \text{ for } i \in \{s, t\}. \end{cases}$$

Let $k, j \in \{x_1, x_2, x_3\}$ with $k \neq j$. If $Gkj \in \mathcal{B}$, then there exists $Y_k, Y_j \in \mathcal{C}^*(\mathcal{M})$ with $\underline{Y}_k = E \setminus \text{cl}(Gk)$, $\sigma(Y_k) \neq 0$, $\underline{Y}_j = E \setminus \text{cl}(Gj)$ and $\sigma(Y_j) \neq 0$. Let $X_k = Y_k \setminus G$ and $X_j = Y_j \setminus G$. Then $X_k, X_j \in \mathcal{M}'$. So

$$\begin{aligned} [Hk, Hj]_p &= [Gpk, Gpj]_p \\ &= \frac{-\overline{Y_j(k) \cdot \sigma(Y_j)^{-1} \cdot \sigma(Y_k) \cdot Y_k(j)^{-1}}}{-\overline{X_j(k) \cdot \sigma'(X_j)^{-1} \cdot \sigma'(X_k) \cdot X_k(j)^{-1}}} \\ &= [\{p, k\}, \{p, j\}]'_p. \end{aligned}$$

If $Gkj \notin \mathcal{B}$, then let $g \in E$ such that $Gkg, Gjg \in \mathcal{B}$. So

$$[Hk, Hj]_p = [Gpk, Gpj]_p = [Gkg, Gjg]_p = [\{k, g\}, \{j, g\}]'_p = [\{k, p\}, \{j, p\}]'_p.$$

So Equation (7) holds because $[\cdot]'_p$ satisfies (P3).

Now we would like to prove the inclusion (8):

$$-1 + [Fy_2y_4, Fy_1y_2]_p \cdot [Fy_1y_3, Fy_3y_4]_p + [Fy_1y_4, Fy_1y_2]_p \cdot [Fy_2y_3, Fy_3y_4]_p \in N_G.$$

By Formula (6) and our argument above, we know that $[\cdot]_p$ satisfies (P1), (P2), (P3) and (P4). So we can multiply both sides of (8) on the left by $[Fy_1y_2, Fy_1y_4]_p$ and on the right by $[Fy_3y_4, Fy_2y_3]_p$, and get

$$-[Fy_1y_2, Fy_1y_4]_p \cdot [Fy_3y_4, Fy_2y_3]_p - [Fy_2y_4, Fy_1y_4]_p \cdot [Fy_1y_3, Fy_2y_3]_p + 1 \in N_G.$$

Then from this inclusion and (8), we know that switching y_1 and y_2 or switching y_1 and y_4 in (8) will result in an inclusion equivalent to the inclusion (8).

Now we begin our proof and will divide it into three cases.

Case 1: $p \notin F \cup \{y_1, y_2, y_3, y_4\}$.

From Formula (6), we know that $[\cdot]$ and $[\cdot]_p$ coincide on each pair of the bases in (8). So the inclusion (8) holds because $[\cdot]$ satisfies (P5).

Case 2: $p \in \{y_1, y_2, y_3, y_4\}$. Then there exists $Y_i \in \mathcal{C}^*(\mathcal{M})$ such that $\underline{Y}_i = E \setminus \text{cl}(Fi)$ and $\sigma(Y_i) \neq 0$ for $i \in \{y_1, y_2, y_3, y_4\} \setminus \{p\}$. Moreover, $\{y_1, y_2, y_3, y_4\} \setminus \{p, i\} \subseteq \underline{Y}_i$ for $i \in \{y_1, y_2, y_3, y_4\} \setminus \{p\}$. We denote $(Y_i, \sigma(Y_i))$ by \tilde{Y}_i .

Case 2.1: If $p \in \{y_1, y_2, y_4\}$, then without loss of generality, we may assume $p = y_1$. Now we consider Y_2 and Y_3 . As $r(F) = d - 2$, then Y_2 and Y_3 form a modular pair in $\mathcal{C}^*(\mathcal{M})$. So $(\tilde{Y}_2, \tilde{Y}_3)$ is a modular pair in $\mathcal{C}^*(\mathcal{M})$. By symmetry in weak circuit axioms, we may assume that $\sigma(Y_2) = -\sigma(Y_3)$. Let $Z = \text{Mod}(Y_2, Y_3, p)$. Then $Z(y_2) = Y_3(y_2)$ and $Y_2(y_4) + Y_3(y_4) - Z(y_4) \in N_G$. So by Formula (6) and Dual Pivoting property,

$$\begin{aligned} & -1 + [Fy_2y_4, Fy_1y_2]_p \cdot [Fy_1y_3, Fy_3y_4]_p + [Fy_1y_4, Fy_1y_2]_p \cdot [Fy_2y_3, Fy_3y_4]_p \\ &= -1 + [Fy_2y_4, Fy_2p]_p \cdot [Fy_3p, Fy_3y_4]_p + [Fy_4p, Fy_2p]_p \cdot [Fy_2y_3, Fy_3y_4]_p \\ &= -1 + \frac{\overline{Y_2(y_4)\sigma(Y_2)^{-1}} \cdot \overline{\sigma(Y_3)Y_3(y_4)^{-1}} + \overline{Z(y_4)Z(y_2)^{-1}} \cdot \overline{Y_3(y_2)Y_3(y_4)^{-1}}}{-\overline{Y_2(y_4)Y_3(y_4)^{-1}} + \overline{Z(y_4)Y_3(y_4)^{-1}}} \\ &= -\overline{(Y_3(y_4) + Y_2(y_4) - Z(y_4)) \cdot Y_3(y_4)^{-1}} \\ &\in N_G. \end{aligned}$$

Case 2.2: If $p = y_3$, then we consider Y_1 and Y_2 . Similarly, $(\tilde{Y}_1, \tilde{Y}_2)$ is a modular pair in $\mathcal{C}^*(\tilde{\mathcal{M}})$. By symmetry in weak circuit axioms, we may assume that $\sigma(Y_1) = -\sigma(Y_2)$. Let $Z = \text{Mod}(Y_1, Y_2, p)$. Then $Z(y_1) = Y_2(y_1)$, $Z(y_2) = Y_1(y_2)$ and $Y_1(y_4) + Y_2(y_4) - Z(y_4) \in N_G$. So by Formula (6) and Dual Pivoting property,

$$\begin{aligned} & -1 + [Fy_2y_4, Fy_1y_2]_p \cdot [Fy_1y_3, Fy_3y_4]_p + [Fy_1y_4, Fy_1y_2]_p \cdot [Fy_2y_3, Fy_3y_4]_p \\ &= -1 + [Fy_2y_4, Fy_1y_2]_p \cdot [Fy_1p, Fy_4p]_p + [Fy_1y_4, Fy_1y_2]_p \cdot [Fy_2p, Fy_4p]_p \\ &= -1 + \overline{Y_2(y_4)Y_2(y_1)^{-1} \cdot Z(y_1)Z(y_4)^{-1}} + \overline{Y_1(y_4)Y_1(y_2)^{-1} \cdot Z(y_2)Z(y_4)^{-1}} \\ &= -1 + \overline{Y_2(y_4)Z(y_4)^{-1}} + \overline{Y_1(y_4)Z(y_4)^{-1}} \\ &= \overline{(-Z(y_4) + Y_2(y_4) + Y_1(y_4)) \cdot Z(y_4)^{-1}} \\ &\in N_G. \end{aligned}$$

Case 3: $p \in F$. Let $G = F \setminus \{p\}$. So $\text{rank}_{\tilde{\mathcal{M}}}(G) = \text{rank}_{\mathcal{M}}(G) = d - 3$.

As $r(Gy_iy_j) = d - 1$ for any two distinct elements $i, j \in \{1, 2, 3, 4\}$, then $r(Gy_iy_jy_k) \geq d - 1$ for any three distinct elements $i, j, k \in \{1, 2, 3, 4\}$. There is an easy case and two harder cases to check:

Case 3.1: $r(Gy_1y_2y_3y_4) = d - 1$. Then $r(Gy_iy_jy_k) = d - 1$ for any three distinct elements $i, j, k \in \{1, 2, 3, 4\}$. So $\text{cl}(Gy_1y_2) = \text{cl}(Gy_1y_3) = \text{cl}(Gy_1y_4) = \text{cl}(Gy_2y_3) = \text{cl}(Gy_2y_4) = \text{cl}(Gy_3y_4)$. Let $e \in E$ such that $Gy_1y_2e \in \mathcal{B}$. Then $Gy_1y_3e, Gy_1y_4e, Gy_2y_3e, Gy_2y_4e, Gy_3y_4e \in \mathcal{B}$. As $[\cdot]$ satisfies (P5), we have

$$\begin{aligned} & -1 + [Fy_2y_4, Fy_1y_2]_p \cdot [Fy_1y_3, Fy_3y_4]_p + [Fy_1y_4, Fy_1y_2]_p \cdot [Fy_2y_3, Fy_3y_4]_p \\ &= -1 + [Gy_2y_4p, Gy_1y_2p]_p \cdot [Gy_1y_3p, Gy_3y_4p]_p + [Gy_1y_4p, Gy_1y_2p]_p \cdot [Gy_2y_3p, Gy_3y_4p]_p \\ &= -1 + [Gy_2y_4e, Gy_1y_2e] \cdot [Gy_1y_3e, Gy_3y_4e] + [Gy_1y_4e, Gy_1y_2e] \cdot [Gy_2y_3e, Gy_3y_4e] \\ &\in N_G. \end{aligned}$$

Case 3.2: $r(Gy_1y_2y_3y_4) = d$, and there exists $f \in \{y_1, y_2, y_3, y_4\}$ such that $r(Gy_1y_2y_3y_4 \setminus \{f\}) = d - 1$.

Case 3.2.1: If $f \in \{y_1, y_2, y_4\}$, then without loss of generality we assume $f = y_2$ and so $r(Gy_1y_3y_4) = d - 1$. So $\text{cl}(Gy_1y_3) = \text{cl}(Gy_1y_4) = \text{cl}(Gy_3y_4) = \text{cl}(Gy_1y_3y_4)$ and $Gy_1y_2y_4, Gy_1y_2y_3, Gy_2y_3y_4 \in \mathcal{B}$. So there exists $Y_{134} \in \mathcal{C}^*(\mathcal{M})$ with $\underline{Y}_{134} = E \setminus \text{cl}(Gy_1y_3y_4) \ni y_2$ and $\sigma(Y_{134}) \neq 0$. Then we have

$$[Gy_1y_4p, Gy_1y_2y_4]_p = \overline{\sigma(Y_{134}) \cdot Y_{134}(y_2)^{-1}} = [Gy_3y_4p, Gy_2y_3y_4]_p.$$

As $[\cdot]_p$ satisfies (P3), then

$$\begin{aligned} [Fy_1y_4, Fy_1y_2]_p &= [Gpy_1y_4, Gpy_1y_2]_p = -[Gy_1y_2y_4, Gy_1y_2p]_p \cdot [Gy_1y_4p, Gy_1y_2y_4]_p, \\ [Fy_2y_3, Fy_3y_4]_p &= [Gpy_2y_3, Gpy_3y_4]_p = -[Gy_2y_3y_4, Gy_3y_4p]_p \cdot [Gy_2y_3p, Gy_2y_3y_4]_p. \end{aligned}$$

So

$$\begin{aligned} & [Fy_1y_4, Fy_1y_2]_p \cdot [Fy_2y_3, Fy_3y_4]_p \\ &= [Gy_1y_2y_4, Gy_1y_2p]_p \cdot [Gy_1y_4p, Gy_1y_2y_4]_p \cdot [Gy_2y_3y_4, Gy_3y_4p]_p \cdot [Gy_2y_3p, Gy_2y_3y_4]_p \\ &= [Gy_1y_2y_4, Gy_1y_2p]_p \cdot [Gy_2y_3p, Gy_2y_3y_4]_p. \end{aligned}$$

As $[\cdot]_p$ satisfies (P4), then

$$[Fy_1y_3, Fy_3y_4]_p = [Gy_1y_3y_2, Gy_3y_4y_2]_p.$$

So to prove the inclusion (8), we only need to verify,

$$-1 + [Gy_2y_4p, Gy_1y_2p]_p \cdot [Gy_1y_3y_2, Gy_3y_4y_2]_p + [Gy_1y_2y_4, Gy_1y_2p]_p \cdot [Gy_2y_3p, Gy_2y_3y_4]_p \in N_G.$$

Let $J = Gy_2$. Let $\mathcal{M}_2 = \mathcal{M}/J$ and $[\cdot]_2 = [\cdot]/J$. \mathcal{M}_2 is a rank 2 contraction of \mathcal{M} and $[\cdot]_2$ are weak left quasi-Pücker coordinates of \mathcal{M}_2 . Let $\sigma_2 : \mathcal{C}^*(\mathcal{M}_2) \rightarrow T$ be the function induced by σ . As σ defines a single-element extension of every rank 2 contraction of \mathcal{M} , then σ_2 is a

localization of \mathcal{M}_2 and we call the corresponding extension $\widetilde{\mathcal{M}}_2$. So by Lemma 3.4, the set of bases of $\widetilde{\mathcal{M}}_2$ is

$$\widetilde{\mathcal{B}}_2 = \mathcal{B}(\mathcal{M}_2) \cup \{\{e, p\} \subseteq (E \setminus J) \cup p \mid (E \setminus J) \setminus \text{cl}_{\mathcal{M}_2}(\{e\}) = \underline{X} \text{ and } \sigma_2(X) \neq 0 \text{ for some } X \in \mathcal{C}^*(\mathcal{M}_2)\}.$$

By Proposition 3.6, the corresponding weak left quasi-Plücker coordinates $[\cdot]_p^2 : A_{\widetilde{\mathcal{B}}_2} \rightarrow T$ are given by

$$[\{e, s\}, \{e, t\}]_p^2 = \begin{cases} [\{e, s\}, \{e, t\}]_2 & \text{if } p \notin \{e, s, t\}, \\ \frac{[\{e, s\}, \{e, t\}]_2}{\sigma_2(X) \cdot X(t)^{-1}} & \text{if } p = s \text{ and } X \in \mathcal{C}^*(\mathcal{M}_2) \text{ with } \underline{X} = (E \setminus J) \setminus \text{cl}_{\mathcal{M}_2}(\{e\}), \\ \frac{[\{e, s\}, \{e, t\}]_2}{X(s) \cdot \sigma_2(X)^{-1}} & \text{if } p = t \text{ and } X \in \mathcal{C}^*(\mathcal{M}_2) \text{ with } \underline{X} = (E \setminus J) \setminus \text{cl}_{\mathcal{M}_2}(\{e\}), \\ [\{s, g\}, \{t, g\}]_2 & \text{if } p = e, \{s, t\} \notin \mathcal{B}(\mathcal{M}_2) \text{ and } \{s, g\}, \{t, g\} \in \mathcal{B}(\mathcal{M}_2) \\ & \text{for some } g \in E \setminus J, \\ \frac{[\{s, g\}, \{t, g\}]_2}{-X_t(s) \cdot \sigma_2(X_t)^{-1} \cdot \sigma_2(X_s) \cdot X_s(t)^{-1}} & \text{if } p = e, \{s, t\} \in \mathcal{B}(\mathcal{M}_2), X_i \in \mathcal{C}^*(\mathcal{M}_2) \text{ with} \\ & \underline{X}_i = (E \setminus J) \setminus \text{cl}_{\mathcal{M}_2}(\{i\}) \text{ for } i \in \{s, t\}. \end{cases}$$

As $Gy_1y_2y_4, Gy_2y_3y_4 \in \mathcal{B}$, then there exists $Y_{2i} \in \mathcal{C}^*(\mathcal{M})$ such that $\underline{Y}_{2i} = E \setminus \text{cl}(Gi y_2) = E \setminus \text{cl}(Ji)$, $\sigma(Y_{2i}) \neq 0$ for $i \in \{1, 3, 4\}$. Let $X_{2i} = Y_{2i} \setminus J$ for $i \in \{1, 3, 4\}$. Then $X_{2i} \in \mathcal{C}^*(\mathcal{M}_2)$ for $i \in \{1, 3, 4\}$. So

$$\begin{aligned} [Gy_2y_4p, Gy_1y_2p]_p &= \frac{[\{p, y_4\}, \{p, y_1\}]_p^2}{-Y_{12}(y_4)\sigma(Y_{12})^{-1}\sigma(Y_{24})Y_{24}(y_1)^{-1}} \\ &= \frac{[\{p, y_4\}, \{p, y_1\}]_p^2}{-X_{12}(y_4)\sigma_2(X_{12})^{-1}\sigma_2(X_{24})X_{24}(y_1)^{-1}} \\ &= [\{p, y_4\}, \{p, y_1\}]_p^2, \\ [Gy_1y_3y_2, Gy_3y_4y_2] &= [\{y_1, y_3\}, \{y_3, y_4\}]_p^2, \\ [Gy_1y_2y_4, Gy_1y_2p]_p \cdot [Gy_2y_3p, Gy_2y_3y_4]_p &= \frac{[\{y_1, y_4\}, \{y_1, p\}]_p^2 \cdot [\{y_3, p\}, \{y_3, y_4\}]_p^2}{Y_{12}(y_4)\sigma(Y_{12})^{-1} \cdot \sigma(Y_{23})Y_{23}(y_4)^{-1}} \\ &= \frac{[\{y_1, y_4\}, \{y_1, p\}]_p^2 \cdot [\{y_3, p\}, \{y_3, y_4\}]_p^2}{X_{12}(y_4)\sigma_2(X_{12})^{-1} \cdot \sigma_2(X_{23})X_{23}(y_4)^{-1}} \\ &= [\{y_1, y_4\}, \{y_1, p\}]_p^2 \cdot [\{y_3, p\}, \{y_3, y_4\}]_p^2. \end{aligned}$$

So to prove the inclusion (8), we only need to verify,

$$-1 + [\{p, y_4\}, \{p, y_1\}]_p^2 \cdot [\{y_1, y_3\}, \{y_3, y_4\}]_p^2 + [\{y_1, y_4\}, \{y_1, p\}]_p^2 \cdot [\{y_3, p\}, \{y_3, y_4\}]_p^2 \in N_G.$$

As σ_2 is a localization of \mathcal{M}_2 , then $[\cdot]_p^2$ satisfies (P5).

So the inclusion (8) holds.

Case 3.2.2: If $f = y_3$, then $r(Gy_1y_2y_4) = d - 1$. So $\text{cl}(Gy_1y_2) = \text{cl}(Gy_1y_4) = \text{cl}(Gy_2y_4) = \text{cl}(Gy_1y_2y_4)$ and $Gy_1y_3y_4, Gy_1y_2y_3, Gy_2y_3y_4 \in \mathcal{B}$. So there exists $Y_{124} \in \mathcal{C}^*(\mathcal{M})$ with $\underline{Y}_{124} = E \setminus \text{cl}(Gy_1y_2y_4) \ni y_3$ and $\sigma(Y_{124}) \neq 0$. Then we have

$$\begin{aligned} [Fy_2y_4, Fy_1y_2]_p &= [Gpy_2y_4, Gpy_1y_2]_p = [Gy_2y_4y_3, Gy_1y_2y_3], \\ [Fy_1y_4, Fy_1y_2]_p &= [Gpy_1y_4, Gpy_1y_2]_p = [Gy_1y_4y_3, Gy_1y_2y_3]. \end{aligned}$$

So to prove the inclusion (8), we only need to verify,

$$-1 + [Gy_2y_4y_3, Gy_1y_2y_3] \cdot [Gpy_1y_3, Gpy_3y_4]_p + [Gy_1y_4y_3, Gy_1y_2y_3] \cdot [Gpy_2y_3, Gpy_3y_4]_p.$$

Let $K = Gy_3$. Let $\mathcal{M}'_2 = \mathcal{M}/K$ and $[\cdot]'_2 = [\cdot]/K$. \mathcal{M}'_2 is a rank 2 contraction of \mathcal{M} and $[\cdot]'_2$ are weak left quasi-Plücker coordinates of \mathcal{M}'_2 . Let $\sigma'_2 : \mathcal{C}^*(\mathcal{M}'_2) \rightarrow T$ be the function induced by σ . As σ defines a single-element extension of every rank 2 contraction of \mathcal{M} , then σ'_2 is a localization of \mathcal{M}'_2 and we call the corresponding extension $\widetilde{\mathcal{M}}'_2$. So by Lemma 3.4, the set of bases of $\widetilde{\mathcal{M}}'_2$ is

$$\widetilde{\mathcal{B}}'_2 = \mathcal{B}(\mathcal{M}'_2) \cup \{\{e, p\} \subseteq (E \setminus K) \cup p \mid (E \setminus K) \setminus \text{cl}_{\mathcal{M}'_2}(\{e\}) = \underline{X} \text{ and } \sigma'_2(X) \neq 0 \text{ for some } X \in \mathcal{C}^*(\mathcal{M}'_2)\}.$$

By Proposition 3.6, the corresponding weak left quasi-Plücker coordinates $[\cdot]_p^2 : A_{\mathcal{B}'_2} \rightarrow T$ are given by

$$[\{e, s\}, \{e, t\}]_p^{2'} = \begin{cases} \frac{[\{e, s\}, \{e, t\}]_2'}{\sigma'_2(X) \cdot X(t)^{-1}} & \text{if } p \notin \{e, s, t\}, \\ \frac{[\{e, s\}, \{e, t\}]_2'}{X(s) \cdot \sigma'_2(X)^{-1}} & \text{if } p = s \text{ and } X \in \mathcal{C}^*(\mathcal{M}'_2) \text{ with } \underline{X} = (E \setminus K) \setminus \text{cl}_{\mathcal{M}'_2}(\{e\}), \\ [\{s, g\}, \{t, g\}]_2' & \text{if } p = t \text{ and } X \in \mathcal{C}^*(\mathcal{M}'_2) \text{ with } \underline{X} = (E \setminus K) \setminus \text{cl}_{\mathcal{M}'_2}(\{e\}), \\ & \text{if } p = e, \{s, t\} \notin \mathcal{B}(\mathcal{M}'_2) \text{ and } \{s, g\}, \{t, g\} \in \mathcal{B}(\mathcal{M}'_2) \\ & \text{for some } g \in E \setminus K, \\ \frac{-X_t(s) \cdot \sigma'_2(X_t)^{-1} \cdot \sigma'_2(X_s) \cdot X_s(t)^{-1}}{\underline{X}_i = (E \setminus K) \setminus \text{cl}_{\mathcal{M}'_2}(\{i\}) \text{ for } i \in \{s, t\}.} & \text{if } p = e, \{s, t\} \in \mathcal{B}(\mathcal{M}'_2), X_i \in \mathcal{C}^*(\mathcal{M}'_2) \text{ with} \end{cases}$$

As $Gy_1y_3y_4, Gy_2y_3y_4 \in \mathcal{B}$, then there exists $Y_{3i} \in \mathcal{C}^*(\mathcal{M})$ such that $\underline{Y}_{3i} = E \setminus \text{cl}(Giy_3) = E \setminus \text{cl}(Ki)$, $\sigma(Y_{3i}) \neq 0$ for $i \in \{1, 2, 4\}$. Let $X_{3i} = Y_{3i} \setminus K$ for $i \in \{1, 2, 4\}$. Then $X_{3i} \in \mathcal{C}^*(\mathcal{M}'_2)$ for $i \in \{1, 2, 4\}$. So

$$\begin{aligned} [Gy_2y_4y_3, Gy_1y_2y_3] &= [\{y_2, y_4\}, \{y_1, y_2\}]_p^{2'}, \\ [Gpy_1y_3, Gpy_3y_4]_p &= \frac{-\overline{Y_{34}(y_1)\sigma(Y_{34})^{-1}\sigma(Y_{13})Y_{13}(y_4)^{-1}}}{-X_{34}(y_1)\sigma'_2(X_{34})^{-1}\sigma'_2(X_{13})X_{13}(y_4)^{-1}} \\ &= [\{y_1, y_3\}, \{y_3, y_4\}]_p^{2'}, \\ [Gy_1y_4y_3, Gy_1y_2y_3] &= [\{y_1, y_4\}, \{y_1, y_2\}]_p^{2'}, \\ [Gpy_2y_3, Gpy_3y_4]_p &= \frac{-\overline{Y_{34}(y_2)\sigma(Y_{34})^{-1}\sigma(Y_{23})Y_{23}(y_4)^{-1}}}{-X_{34}(y_2)\sigma'_2(X_{34})^{-1}\sigma'_2(X_{23})X_{23}(y_4)^{-1}} \\ &= [\{y_2, y_3\}, \{y_3, y_4\}]_p^{2'}. \end{aligned}$$

So to prove the inclusion (8), we only need to verify,

$$-1 + [\{y_2, y_4\}, \{y_1, y_2\}]_p^{2'} \cdot [\{y_1, y_3\}, \{y_3, y_4\}]_p^{2'} + [\{y_1, y_4\}, \{y_1, y_2\}]_p^{2'} \cdot [\{y_2, y_3\}, \{y_3, y_4\}]_p^{2'}.$$

As σ'_2 is a localization of \mathcal{M}'_2 , then $[\cdot]_p^{2'}$ satisfies (P5).

So the inclusion (8) holds.

Case 3.3: For any three distinct elements $i, j, k \in \{1, 2, 3, 4\}$, $r(Gy_iy_jy_k) = d$. Then for each partition $\{i, j\} \cup \{k, l\}$ of $\{1, 2, 3, 4\}$, there exists $Y_{ij} \in \mathcal{C}^*(\mathcal{M})$ such that $\underline{Y}_{ij} = E \setminus \text{cl}(Gy_iy_j)$, $\sigma(Y_{ij}) \neq 0$ and $y_k, y_l \in \underline{Y}_{ij}$. By symmetry in weak circuit axioms, we may assume $Y_{23}(y_1) = Y_{13}(y_2) = Y_{12}(y_3) = Y_{24}(y_1) = -Y_{34}(y_1) = 1$ and $Y_{14}(y_2) = Y_{13}(y_4)^{-1}Y_{23}(y_4)$. By Lemma 5.5, we can choose $\sigma(Y_{23}) = 1$. We list values of $Y_{23}, Y_{13}, Y_{12}, Y_{34}, Y_{24}$ and Y_{14} on elements $\{y_1, y_2, y_3, y_4\}$ and the corresponding σ values in Table 4.

We now find relationships between some numbers in this table.

Let $\alpha \in T^\times$ with $\alpha = Y_{12}(y_4)^{-1}Y_{23}(y_4)$. We consider the rank 2 contraction \mathcal{M}/Gy_2 . Let $\sigma_{y_2} : \mathcal{C}^*(\mathcal{M}/Gy_2) \rightarrow T$ be the function induced by σ . As σ is a localization on the rank 2 contraction \mathcal{M}/Gy_2 , then σ_{y_2} is a localization of \mathcal{M}/Gy_2 . Now we consider the T -cocircuits $Y_{23} \setminus Gy_2, Y_{12} \setminus Gy_2 \cdot (-\alpha)$ and $Y_{24} \setminus Gy_2$ of \mathcal{M}/Gy_2 . We list their values on elements $\{y_1, y_3, y_4\}$ and the corresponding σ_{y_2} values in Table 5,

	y_1	y_2	y_3	y_4	σ
Y_{23}	1	0	0	$Y_{23}(y_4)$	1
Y_{13}	0	1	0	$Y_{13}(y_4)$	$\sigma(Y_{13})$
Y_{12}	0	0	1	$Y_{12}(y_4)$	$\sigma(Y_{12})$
Y_{24}	1	0	$Y_{24}(y_3)$	0	$\sigma(Y_{24})$
Y_{34}	-1	$Y_{34}(y_2)$	0	0	$\sigma(Y_{34})$
Y_{14}	0	$Y_{13}(y_4)^{-1}Y_{23}(y_4)$	$Y_{14}(y_3)$	0	$\sigma(Y_{14})$

TABLE 4

	y_1	y_3	y_4	σ_{y_2}
$Y_{23} \setminus Gy_2$	1	0	$Y_{23}(y_4)$	1
$Y_{12} \setminus Gy_2 \cdot (-\alpha)$	0	$-\alpha$	$-Y_{23}(y_4)$	$\sigma(Y_{12}) \cdot (-\alpha)$
$Y_{24} \setminus Gy_2$	1	$Y_{24}(y_3)$	0	$\sigma(Y_{24})$

TABLE 5

Note that $Y_{24} \setminus Gy_2$ eliminates y_4 between $Y_{23} \setminus Gy_2$ and $Y_{12} \setminus Gy_2 \cdot (-\alpha)$. So

$$Y_{24}(y_3) = -\alpha.$$

Also as σ_{y_2} is a localization of \mathcal{M}/Gy_2 , then by Lemma 5.4

$$1 - \sigma(Y_{12})\alpha - \sigma(Y_{24}) \in N_G. \quad (9)$$

We still consider \mathcal{M}/Gy_2 . $(Y_{23} \setminus Gy_2, Y_{12} \setminus Gy_2 \cdot (-\sigma(Y_{12})^{-1}))$ forms a modular pair in $\mathcal{C}^*(\mathcal{M}/Gy_2)$ and $\sigma_{y_2}(Y_{23} \setminus Gy_2) = 1 = -\sigma_{y_2}(Y_{12} \setminus Gy_2 \cdot (-\sigma(Y_{12})^{-1}))$. We apply Lemma 3.7 with choosing $Y_1 = Y_{23} \setminus Gy_2$, $Y_2 = Y_{12} \setminus Gy_2 \cdot (-\sigma(Y_{12})^{-1})$, $e_1 = y_3$, $e = y_4$ and $Y_e = Y_{24} \setminus Gy_2$, and get

$$\begin{aligned} \text{Mod}(Y_1, Y_2, p)(y_4) &= -Y_{23}(y_4) \cdot \sigma(Y_{23})^{-1} \cdot \sigma(Y_{24}) \cdot Y_{24}(y_3)^{-1} \cdot (Y_{12}(y_3) \cdot (-\sigma(Y_{12})^{-1})) \\ &= -Y_{23}(y_4) \cdot \sigma(Y_{24}) \cdot \alpha^{-1} \cdot \sigma(Y_{12})^{-1}. \end{aligned}$$

Similarly, we apply Lemma 3.7 with choosing $Y'_1 = Y_{12} \setminus Gy_2 \cdot (-\sigma(Y_{12})^{-1})$, $Y'_2 = Y_{23} \setminus Gy_2$, $e_1 = y_1$, $e = y_4$ and $Y_e = Y_{24} \setminus Gy_2$, and get

$$\begin{aligned} \text{Mod}(Y'_1, Y'_2, p)(y_4) &= -(-Y_{12}(y_4) \cdot \sigma(Y_{12})^{-1}) \cdot (-1) \cdot \sigma(Y_{24}) \cdot Y_{24}(y_1)^{-1} \cdot Y_{23}(y_1) \\ &= -Y_{12}(y_4) \cdot \sigma(Y_{12})^{-1} \cdot \sigma(Y_{24}). \end{aligned}$$

As $\text{Mod}(Y_1, Y_2, p)(y_4) = \text{Mod}(Y'_1, Y'_2, p)(y_4)$, then

$$-Y_{23}(y_4) \cdot \sigma(Y_{24}) \cdot \alpha^{-1} \cdot \sigma(Y_{12})^{-1} = -Y_{12}(y_4) \cdot \sigma(Y_{12})^{-1} \cdot \sigma(Y_{24}).$$

Multiplying on the left by $-Y_{23}(y_4)^{-1}$ and we get

$$\begin{aligned} \sigma(Y_{24}) \cdot \alpha^{-1} \cdot \sigma(Y_{12})^{-1} &= \alpha^{-1} \cdot \sigma(Y_{12})^{-1} \cdot \sigma(Y_{24}). \\ \sigma(Y_{24}) \cdot (\sigma(Y_{12}) \cdot \alpha)^{-1} &= (\sigma(Y_{12}) \cdot \alpha)^{-1} \cdot \sigma(Y_{24}). \end{aligned} \quad (10)$$

Next, let $\beta \in T^\times$ with $\beta = Y_{13}(y_4)^{-1}Y_{23}(y_4)$. We consider the rank 2 contraction \mathcal{M}/Gy_3 . Let $\sigma_{y_3} : \mathcal{C}^*(\mathcal{M}/Gy_3) \rightarrow T$ be the function induced by σ . As σ is a localization on the rank 2 contraction \mathcal{M}/Gy_3 , then σ_{y_3} is a localization of \mathcal{M}/Gy_3 . Now we consider the T -cocircuits $-Y_{23} \setminus Gy_3$, $Y_{13} \setminus Gy_3 \cdot \beta$ and $Y_{34} \setminus Gy_3$. We list their values on elements $\{y_1, y_2, y_4\}$ and the corresponding σ_{y_3} values in Table 6.

	y_1	y_2	y_4	σ_{y_3}
$-Y_{23} \setminus G y_3$	-1	0	$-Y_{23}(y_4)$	-1
$Y_{13} \setminus G y_3 \cdot \beta$	0	β	$Y_{23}(y_4)$	$\sigma(Y_{13}) \cdot \beta$
$Y_{34} \setminus G y_3$	-1	$Y_{34}(y_2)$	0	$\sigma(Y_{34})$

TABLE 6

Note that $Y_{34} \setminus G y_3$ eliminates y_4 between $-Y_{23} \setminus G y_3$ and $Y_{13} \setminus G y_3 \cdot \beta$. So

$$Y_{34}(y_2) = \beta.$$

Also as σ_{y_3} is a localization of $\mathcal{M}/G y_3$, then by Lemma 5.4

$$-1 + \sigma(Y_{13})\beta - \sigma(Y_{34}) \in N_G. \quad (11)$$

We still consider $\mathcal{M}/G y_3$. $(-Y_{23} \setminus G y_3, Y_{13} \setminus G y_3 \cdot \sigma(Y_{13})^{-1})$ forms a modular pair in $\mathcal{C}^*(\mathcal{M}/G y_3)$ and $\sigma_{y_3}(-Y_{23} \setminus G y_3) = -1 = -\sigma_{y_3}(Y_{13} \setminus G y_3 \cdot \sigma(Y_{13})^{-1})$. We apply Lemma 3.7 with choosing $Y_1 = -Y_{23} \setminus G y_3$, $Y_2 = Y_{13} \setminus G y_3 \cdot \sigma(Y_{13})^{-1}$, $e_1 = y_2$, $e = y_4$ and $Y_e = Y_{34} \setminus G y_3$, and get

$$\begin{aligned} \text{Mod}(Y_1, Y_2, p)(y_4) &= -(-Y_{23}(y_4)) \cdot (-\sigma(Y_{23})^{-1}) \cdot \sigma(Y_{34}) \cdot Y_{34}(y_2)^{-1} \cdot (Y_{13}(y_2) \cdot \sigma(Y_{13})^{-1}) \\ &= -Y_{23}(y_4) \cdot \sigma(Y_{34}) \cdot \beta^{-1} \cdot \sigma(Y_{13})^{-1}. \end{aligned}$$

Similarly, we apply Lemma 3.7 with choosing $Y'_1 = Y_{13} \setminus G y_3 \cdot \sigma(Y_{13})^{-1}$, $Y'_2 = -Y_{23} \setminus G y_3$, $e_1 = y_1$, $e = y_4$ and $Y_e = Y_{34} \setminus G y_3$, and get

$$\begin{aligned} \text{Mod}(Y'_1, Y'_2, p)(y_4) &= -(Y_{13}(y_4) \cdot \sigma(Y_{13})^{-1}) \cdot 1 \cdot \sigma(Y_{34}) \cdot Y_{34}(y_1)^{-1} \cdot (-Y_{23}(y_1)) \\ &= -Y_{13}(y_4) \cdot \sigma(Y_{13})^{-1} \cdot \sigma(Y_{34}). \end{aligned}$$

As $\text{Mod}(Y_1, Y_2, p)(y_4) = \text{Mod}(Y'_1, Y'_2, p)(y_4)$, then

$$-Y_{23}(y_4) \cdot \sigma(Y_{34}) \cdot \beta^{-1} \cdot \sigma(Y_{13})^{-1} = -Y_{13}(y_4) \cdot \sigma(Y_{13})^{-1} \cdot \sigma(Y_{34}).$$

Multiplying on the left by $-Y_{23}(y_4)^{-1}$ and we get

$$\begin{aligned} \sigma(Y_{34}) \cdot \beta^{-1} \cdot \sigma(Y_{13})^{-1} &= \beta^{-1} \cdot \sigma(Y_{13})^{-1} \cdot \sigma(Y_{34}). \\ \sigma(Y_{34}) \cdot (\sigma(Y_{13}) \cdot \beta)^{-1} &= (\sigma(Y_{13}) \cdot \beta)^{-1} \cdot \sigma(Y_{34}). \end{aligned} \quad (12)$$

Next, we consider the rank 2 contraction $\mathcal{M}/G y_1$. Let $\sigma_{y_1} : \mathcal{C}^*(\mathcal{M}/G y_1) \rightarrow T$ be the function induced by σ . As σ is a localization on the rank 2 contraction $\mathcal{M}/G y_1$, then σ_{y_1} is a localization of $\mathcal{M}/G y_1$. Now we consider the T -cocircuits $Y_{13} \setminus G y_1 \cdot \beta$, $Y_{12} \setminus G y_1 \cdot (-\alpha)$ and $Y_{14} \setminus G y_1$. We list their values on elements $\{y_2, y_3, y_4\}$ and the corresponding σ_{y_1} values in Table 7.

	y_2	y_3	y_4	σ_{y_1}
$Y_{13} \setminus G y_1 \cdot \beta$	β	0	$Y_{23}(y_4)$	$\sigma(Y_{13}) \cdot \beta$
$Y_{12} \setminus G y_1 \cdot (-\alpha)$	0	$-\alpha$	$-Y_{23}(y_4)$	$\sigma(Y_{12}) \cdot (-\alpha)$
$Y_{14} \setminus G y_1$	β	$Y_{14}(y_3)$	0	$\sigma(Y_{14})$

TABLE 7

Note that $Y_{14} \setminus G y_1$ eliminates y_4 between $Y_{13} \setminus G y_1 \cdot \beta$ and $Y_{12} \setminus G y_1 \cdot (-\alpha)$. So

$$Y_{14}(y_3) = -\alpha.$$

Also as σ_{y_1} is a localization of $\mathcal{M}/G y_1$, then by Lemma 5.4

$$\sigma(Y_{13})\beta - \sigma(Y_{12})\alpha - \sigma(Y_{14}) \in N_G. \quad (13)$$

We still consider \mathcal{M}/Gy_1 . $(Y_{13}\backslash Gy_1 \cdot \sigma(Y_{13})^{-1}, Y_{12}\backslash Gy_1 \cdot (-\sigma(Y_{12})^{-1}))$ forms a modular pair in $\mathcal{C}^*(\mathcal{M}/Gy_1)$ and $\sigma_{y_1}(Y_{13}\backslash Gy_1 \cdot \sigma(Y_{13})^{-1}) = 1 = -\sigma_{y_1}(Y_{12}\backslash Gy_1 \cdot (-\sigma(Y_{12})^{-1}))$. We apply Lemma 3.7 with choosing $Y_1 = Y_{13}\backslash Gy_1 \cdot \sigma(Y_{13})^{-1}$, $Y_2 = Y_{12}\backslash Gy_1 \cdot (-\sigma(Y_{12})^{-1})$, $e_1 = y_3$, $e = y_4$ and $Y_e = Y_{14}\backslash Gy_1$, and get

$$\begin{aligned} \text{Mod}(Y_1, Y_2, p)(y_4) &= -(Y_{13}(y_4) \cdot \sigma(Y_{13})^{-1}) \cdot 1 \cdot \sigma(Y_{14}) \cdot Y_{14}(y_3)^{-1} \cdot (-Y_{12}(y_3) \cdot \sigma(Y_{12})^{-1}) \\ &= -Y_{13}(y_4) \cdot \sigma(Y_{13})^{-1} \cdot \sigma(Y_{14}) \cdot \alpha^{-1} \cdot \sigma(Y_{12})^{-1}. \end{aligned}$$

Similarly, we apply Lemma 3.7 with choosing $Y'_1 = Y_{12}\backslash Gy_1 \cdot (-\sigma(Y_{12})^{-1})$, $Y'_2 = Y_{13}\backslash Gy_1 \cdot \sigma(Y_{13})^{-1}$, $e_1 = y_2$, $e = y_4$ and $Y_e = Y_{14}\backslash Gy_1$, and get

$$\begin{aligned} \text{Mod}(Y'_1, Y'_2, p)(y_4) &= -(-Y_{12}(y_4) \cdot \sigma(Y_{12})^{-1}) \cdot (-1) \cdot \sigma(Y_{14}) \cdot Y_{14}(y_2)^{-1} \cdot (Y_{13}(y_2) \cdot \sigma(Y_{13})^{-1}) \\ &= -Y_{12}(y_4) \cdot \sigma(Y_{12})^{-1} \cdot \sigma(Y_{14}) \cdot \beta^{-1} \cdot \sigma(Y_{13})^{-1}. \end{aligned}$$

As $\text{Mod}(Y_1, Y_2, p)(y_4) = \text{Mod}(Y'_1, Y'_2, p)(y_4)$, then

$$-Y_{13}(y_4) \cdot \sigma(Y_{13})^{-1} \cdot \sigma(Y_{14}) \cdot \alpha^{-1} \cdot \sigma(Y_{12})^{-1} = -Y_{12}(y_4) \cdot \sigma(Y_{12})^{-1} \cdot \sigma(Y_{14}) \cdot \beta^{-1} \cdot \sigma(Y_{13})^{-1}.$$

Multiplying on the left by $-Y_{23}(y_4)^{-1}$ and we get

$$\begin{aligned} \beta^{-1} \cdot \sigma(Y_{13})^{-1} \cdot \sigma(Y_{14}) \cdot \alpha^{-1} \cdot \sigma(Y_{12})^{-1} &= \alpha^{-1} \cdot \sigma(Y_{12})^{-1} \cdot \sigma(Y_{14}) \cdot \beta^{-1} \cdot \sigma(Y_{13})^{-1}. \\ (\sigma(Y_{13}) \cdot \beta)^{-1} \cdot \sigma(Y_{14}) \cdot (\sigma(Y_{12}) \cdot \alpha)^{-1} &= (\sigma(Y_{12}) \cdot \alpha)^{-1} \cdot \sigma(Y_{14}) \cdot (\sigma(Y_{13}) \cdot \beta)^{-1}. \end{aligned} \quad (14)$$

Next, we consider the rank 2 contraction \mathcal{M}/Gy_4 . Let $\sigma_{y_4} : \mathcal{C}^*(\mathcal{M}/Gy_4) \rightarrow T$ be the function induced by σ . As σ is a localization on the rank 2 contraction \mathcal{M}/Gy_4 , then σ_{y_4} is a localization of \mathcal{M}/Gy_4 . Now we consider the T -cocircuits $Y_{24}\backslash Gy_4$, $Y_{34}\backslash Gy_4$ and $Y_{14}\backslash Gy_4$. We list their values on elements $\{y_1, y_2, y_3\}$ and the corresponding σ_{y_4} values in Table 8.

	y_1	y_2	y_3	σ_{y_4}
$Y_{24}\backslash Gy_4$	1	0	$Y_{24}(y_3)$	$\sigma(Y_{24})$
$Y_{34}\backslash Gy_4$	-1	$Y_{34}(y_2)$	0	$\sigma(Y_{34})$
$Y_{14}\backslash Gy_4$	0	β	$Y_{14}(y_3)$	$\sigma(Y_{14})$

TABLE 8

As $Y_{34}(y_2) = \beta$, then $Y_{14}\backslash Gy_4$ eliminates y_1 between $Y_{24}\backslash Gy_4$ and $Y_{34}\backslash Gy_4$. So

$$Y_{14}(y_3) = Y_{24}(y_3) = -\alpha.$$

As σ_{y_4} is a localization of \mathcal{M}/Gy_4 , then by Lemma 5.4

$$\sigma(Y_{24}) + \sigma(Y_{34}) - \sigma(Y_{14}) \in N_G. \quad (15)$$

We still consider \mathcal{M}/Gy_4 . $(Y_{24}\backslash Gy_4 \cdot \sigma(Y_{24})^{-1}, Y_{34}\backslash Gy_4 \cdot (-\sigma(Y_{34})^{-1}))$ forms a modular pair in $\mathcal{C}^*(\mathcal{M}/Gy_4)$ and $\sigma_{y_4}(Y_{24}\backslash Gy_4 \cdot \sigma(Y_{24})^{-1}) = 1 = -\sigma_{y_4}(Y_{34}\backslash Gy_4 \cdot (-\sigma(Y_{34})^{-1}))$. We apply Lemma 3.7 with choosing $Y_1 = Y_{24}\backslash Gy_4 \cdot \sigma(Y_{24})^{-1}$, $Y_2 = Y_{34}\backslash Gy_4 \cdot (-\sigma(Y_{34})^{-1})$, $e_1 = y_2$, $e = y_1$ and $Y_e = Y_{14}\backslash Gy_4$, and get

$$\begin{aligned} \text{Mod}(Y_1, Y_2, p)(y_1) &= -(Y_{24}(y_1) \cdot \sigma(Y_{24})^{-1}) \cdot 1 \cdot \sigma(Y_{14}) \cdot Y_{14}(y_2)^{-1} \cdot (-Y_{34}(y_2) \cdot \sigma(Y_{34})^{-1}) \\ &= -\sigma(Y_{24})^{-1} \cdot \sigma(Y_{14}) \cdot \beta^{-1} \cdot (-\beta \cdot \sigma(Y_{34})^{-1}) \\ &= \sigma(Y_{24})^{-1} \cdot \sigma(Y_{14}) \cdot \sigma(Y_{34})^{-1}. \end{aligned}$$

Similarly, we apply Lemma 3.7 with choosing $Y'_1 = Y_{34}\backslash Gy_4 \cdot (-\sigma(Y_{34})^{-1})$, $Y'_2 = Y_{24}\backslash Gy_4 \cdot \sigma(Y_{24})^{-1}$, $e_1 = y_3$, $e = y_1$ and $Y_e = Y_{14}\backslash Gy_4$, and get

$$\text{Mod}(Y'_1, Y'_2, p)(y_1) = -(-Y_{34}(y_1) \cdot \sigma(Y_{34})^{-1}) \cdot (-1) \cdot \sigma(Y_{14}) \cdot Y_{14}(y_3)^{-1} \cdot (Y_{24}(y_3) \cdot \sigma(Y_{24})^{-1})$$

$$\begin{aligned}
&= \sigma(Y_{34})^{-1} \cdot \sigma(Y_{14}) \cdot (-\alpha)^{-1} \cdot (-\alpha \cdot \sigma(Y_{24})^{-1}) \\
&= \sigma(Y_{34})^{-1} \cdot \sigma(Y_{14}) \cdot \sigma(Y_{24})^{-1}.
\end{aligned}$$

As $\text{Mod}(Y_1, Y_2, p)(y_1) = \text{Mod}(Y'_1, Y'_2, p)(y_1)$, then we get

$$\sigma(Y_{24})^{-1} \cdot \sigma(Y_{14}) \cdot \sigma(Y_{34})^{-1} = \sigma(Y_{34})^{-1} \cdot \sigma(Y_{14}) \cdot \sigma(Y_{24})^{-1}. \quad (16)$$

So now we can revise our previous Table 4 to Table 9.

	y_1	y_2	y_3	y_4	σ
Y_{23}	1	0	0	$Y_{23}(y_4)$	1
Y_{13}	0	1	0	$Y_{13}(y_4)$	$\sigma(Y_{13})$
Y_{12}	0	0	1	$Y_{12}(y_4)$	$\sigma(Y_{12})$
Y_{24}	1	0	$-\alpha$	0	$\sigma(Y_{24})$
Y_{34}	-1	β	0	0	$\sigma(Y_{34})$
Y_{14}	0	β	$-\alpha$	0	$\sigma(Y_{14})$

TABLE 9

Then from Formula (6) and by values in Table 9, we have

$$\begin{aligned}
[Fy_2y_4, Fy_1y_2]_p &= \overline{-Y_{12}(y_4)\sigma(Y_{12})^{-1}\sigma(Y_{24})Y_{24}(y_1)^{-1}} = \overline{-Y_{12}(y_4)\sigma(Y_{12})^{-1}\sigma(Y_{24})}, \\
[Fy_1y_3, Fy_3y_4]_p &= \overline{-Y_{34}(y_1)\sigma(Y_{34})^{-1}\sigma(Y_{13})Y_{13}(y_4)^{-1}} = \overline{\sigma(Y_{34})^{-1}\sigma(Y_{13})Y_{13}(y_4)^{-1}}, \\
[Fy_1y_4, Fy_1y_2]_p &= \overline{-Y_{12}(y_4)\sigma(Y_{12})^{-1}\sigma(Y_{14})Y_{14}(y_2)^{-1}} = \overline{-Y_{12}(y_4)\sigma(Y_{12})^{-1}\sigma(Y_{14})\beta^{-1}}, \\
[Fy_2y_3, Fy_3y_4]_p &= \overline{-Y_{34}(y_2)\sigma(Y_{34})^{-1}\sigma(Y_{23})Y_{23}(y_4)^{-1}} = \overline{-\beta\sigma(Y_{34})^{-1}Y_{23}(y_4)^{-1}}.
\end{aligned}$$

Thus the inclusion (8) can be written as

$$\begin{aligned}
&N_G \\
&\ni -1 + [Fy_2y_4, Fy_1y_2]_p \cdot [Fy_1y_3, Fy_3y_4]_p + [Fy_1y_4, Fy_1y_2]_p \cdot [Fy_2y_3, Fy_3y_4]_p \\
&= -1 + \overline{(-Y_{12}(y_4)\sigma(Y_{12})^{-1}\sigma(Y_{24})) \cdot \sigma(Y_{34})^{-1}\sigma(Y_{13})Y_{13}(y_4)^{-1}} + \\
&\quad \overline{(-Y_{12}(y_4)\sigma(Y_{12})^{-1}\sigma(Y_{14})\beta^{-1}) \cdot (-\beta\sigma(Y_{34})^{-1}Y_{23}(y_4)^{-1})} \\
&= \overline{-1 - Y_{12}(y_4)\sigma(Y_{12})^{-1}\sigma(Y_{24})\sigma(Y_{34})^{-1}\sigma(Y_{13})Y_{13}(y_4)^{-1} + Y_{12}(y_4)\sigma(Y_{12})^{-1}\sigma(Y_{14})\sigma(Y_{34})^{-1}Y_{23}(y_4)^{-1}} \\
&= \overline{-Y_{12}(y_4)\sigma(Y_{12})^{-1} \cdot (\sigma(Y_{12})Y_{12}(y_4)^{-1}Y_{23}(y_4)\sigma(Y_{34}) + \sigma(Y_{24})\sigma(Y_{34})^{-1}\sigma(Y_{13})Y_{13}(y_4)^{-1}Y_{23}(y_4)\sigma(Y_{34}) - \sigma(Y_{14}))} \\
&\quad \cdot \overline{\sigma(Y_{34})^{-1}Y_{23}(y_4)^{-1}} \\
&= \overline{-Y_{12}(y_4)\sigma(Y_{12})^{-1} \cdot (\sigma(Y_{12})\alpha\sigma(Y_{34}) + \sigma(Y_{24})\sigma(Y_{34})^{-1}\sigma(Y_{13})\beta\sigma(Y_{34}) - \sigma(Y_{14})) \cdot \sigma(Y_{34})^{-1}Y_{23}(y_4)^{-1}}.
\end{aligned}$$

Now we will use Pathetic Cancellation to see that

$$\sigma(Y_{12})\alpha\sigma(Y_{34}) + \sigma(Y_{24})\sigma(Y_{34})^{-1}\sigma(Y_{13})\beta\sigma(Y_{34}) - \sigma(Y_{14}) \in N_G,$$

from which the inclusion (8) will hold.

Let

$$\begin{aligned}
a &= -\sigma(Y_{12})\alpha, \\
b &= \sigma(Y_{13})\beta, \\
x &= \sigma(Y_{24}), \\
y &= \sigma(Y_{34}),
\end{aligned}$$

$$z = \sigma(Y_{14}).$$

Then we can restate the inclusion (9), (10), (11), (12), (13), (14), (15) and (16) as

$$\begin{aligned} 1 + a - x &\in N_G, \\ xa^{-1} &= a^{-1}x \quad \text{implying} \quad ax = xa, \\ -1 + b - y &\in N_G, \\ yb^{-1} &= b^{-1}y \quad \text{implying} \quad by = yb, \\ b + a - z &\in N_G, \\ b^{-1}za^{-1} &= a^{-1}zb^{-1}, \\ x + y - z &\in N_G, \\ x^{-1}zy^{-1} &= y^{-1}zx^{-1}. \end{aligned}$$

All of these inclusions are exactly the hypothesis of Pathetic Cancellation property. So by Pathetic Cancellation,

$$xb - ay - z = xy^{-1}by - ay - z = \sigma(Y_{24})\sigma(Y_{34})^{-1}\sigma(Y_{13})\beta\sigma(Y_{34}) + \sigma(Y_{12})\alpha\sigma(Y_{34}) - \sigma(Y_{14}) \in N_G.$$

So the inclusion (8) holds. □

We can get the following Corollary to Lemma 5.4, Lemma 4.4 and Theorem 5.1.

Corollary 5.9. *Let \mathcal{M} be a weak left (resp. right) T -matroid and let $\sigma : \mathcal{C}^*(\mathcal{M}) \rightarrow T$ be a right (resp. left) T^\times -equivariant function. Then σ is a weak localization if and only if for any modular pair (Y_1, Y_2) of T -cocircuits with $Y_1(e) = -Y_2(e) \neq 0$ for some $e \in E$ and Y_3 eliminating e between Y_1 and Y_2 , we have $\sigma(Y_1) + \sigma(Y_2) - \sigma(Y_3) \in N_G$.*

Finally, we finish the proof of our main theorem (Theorem 1.5) in this paper.

There is also an interesting fact showed in Su's thesis ([Su18]) that a hyperfield not satisfying the Pathetic Cancellation property might fail even weaker generalization of Crapo and Las Vergnas' characterization of extensions, as follows.

Theorem 5.10. [Su18] *There is a strong T -matroid \mathcal{M} of rank 4 on 6 elements and a T^\times -equivariant function $\sigma : \mathcal{C}^*(\mathcal{M}) \rightarrow T$ such that σ defines a strong single-element extension by a new element p on every contraction of \mathcal{M} of rank ≤ 3 but σ is not a strong localization.*

6. STRINGENT SKEW HYPERFIELDS

Stringent skew hyperfields behave in many ways like skew fields and the notions of weak and strong F -matroid coincide if F is stringent ([BP19]). This leads to a strengthening of Theorem 5.1, given in Theorem 1.6.

6.1. Characterization of strong Pathetic Cancellation for skew hyperfields. In this section, we will first show a stronger property that implies Pathetic Cancellation for skew hyperfields.

Definition 6.1. Let F be a skew hyperfield. We say F satisfies the **strong Pathetic Cancellation Property** if for every $a, b, x, y \in F^\times$ with $x \in 1 \boxplus a$ and $y \in -1 \boxplus b$ we have

$$(x \boxplus y) \cap (a \boxplus b) \subseteq xb \boxplus -ay,$$

It is easy to see that the strong Pathetic Cancellation Property and the Pathetic Cancellation Property will be the same when F is a hyperfield.

Theorem 6.2. *Let F be a skew hyperfield. If F satisfies strong Pathetic Cancellation, then F satisfies Pathetic Cancellation.*

Proof. Let $a, b, x, y, z \in F^\times$ with $x \in 1 \boxplus a$, $ax = xa$, $y \in -1 \boxplus b$, $by = yb$, $z \in a \boxplus b$, $a^{-1}zb^{-1} = b^{-1}za^{-1}$, $z \in x \boxplus y$ and $x^{-1}zy^{-1} = y^{-1}zx^{-1}$. As F satisfies strong Pathetic Cancellation, then

$$z \in (x \boxplus y) \cap (a \boxplus b) \subseteq xb \boxplus -ay.$$

So F satisfies Pathetic Cancellation. \square

Proposition 6.3. *Let F be a skew hyperfield. The following are equivalent.*

(1) *F satisfies strong Pathetic Cancellation.*

(2) *For any $a, b \in F^\times$ and x, y in F with $x \in 1 \boxplus a$, $y \in -1 \boxplus b$, we have*

$$(x \boxplus y) \cap (a \boxplus b) \subseteq xb \boxplus -ay,$$

$$(a \boxplus b) \cap (xb \boxplus -ay) \subseteq x \boxplus y,$$

$$(x \boxplus y) \cap (xb \boxplus -ay) \subseteq a \boxplus b.$$

(3) *For any $a, b \in F^\times$ and x, y in F with $x \in 1 \boxplus a$, $y \in -1 \boxplus b$, we have*

$$(x \boxplus y) \cap (a \boxplus b) = (x \boxplus y) \cap (xb \boxplus -ay) = (a \boxplus b) \cap (xb \boxplus -ay).$$

Proof. (1) \Rightarrow (3): By definition, for any $x \in 1 \boxplus a$, $y \in -1 \boxplus b$, we have

$$(x \boxplus y) \cap (a \boxplus b) \subseteq xb \boxplus -ay.$$

Then

$$(x \boxplus y) \cap (a \boxplus b) \subseteq (xb \boxplus -ay) \cap (x \boxplus y) \tag{17}$$

and

$$(x \boxplus y) \cap (a \boxplus b) \subseteq (xb \boxplus -ay) \cap (a \boxplus b). \tag{18}$$

As $x \in 1 \boxplus a$ and $y \in -1 \boxplus b$, then $a^{-1}x \in 1 \boxplus a^{-1}$ and $-yb^{-1} \in -1 \boxplus b^{-1}$. By strong Pathetic Cancellation, we have

$$(a^{-1} \boxplus b^{-1}) \cap (a^{-1}x \boxplus -yb^{-1}) \subseteq a^{-1}xb^{-1} \boxplus a^{-1}yb^{-1} = a^{-1}(x \boxplus y)b^{-1},$$

thus

$$(a \boxplus b) \cap (xb \boxplus -ay) \subseteq x \boxplus y.$$

Then

$$(a \boxplus b) \cap (xb \boxplus -ay) \subseteq (x \boxplus y) \cap (a \boxplus b). \tag{19}$$

and

$$(a \boxplus b) \cap (xb \boxplus -ay) \subseteq (x \boxplus y) \cap (xb \boxplus -ay). \tag{20}$$

Similarly, as $x \in 1 \boxplus a$ and $y \in -1 \boxplus b$, then $x^{-1}a \in 1 \boxplus -x^{-1}$ and $-by^{-1} \in -1 \boxplus -y^{-1}$. By strong Pathetic Cancellation, we have

$$(-x^{-1} \boxplus -y^{-1}) \cap (x^{-1}a \boxplus -by^{-1}) \subseteq -x^{-1}ay^{-1} \boxplus -x^{-1}by^{-1} = -x^{-1}(a \boxplus b)y^{-1},$$

thus

$$(x \boxplus y) \cap (xb \boxplus -ay) \subseteq a \boxplus b.$$

Then

$$(x \boxplus y) \cap (xb \boxplus -ay) \subseteq (a \boxplus b) \cap (x \boxplus y). \tag{21}$$

and

$$(x \boxplus y) \cap (xb \boxplus -ay) \subseteq (a \boxplus b) \cap (xb \boxplus -ay). \tag{22}$$

So by Inclusion (17), (18), (19), (20), (21) and (22), we have

$$(x \boxplus y) \cap (a \boxplus b) = (x \boxplus y) \cap (xb \boxplus -ay) = (a \boxplus b) \cap (xb \boxplus -ay).$$

(3) \Rightarrow (2): If for any x, y in F with $x \in 1 \boxplus a$, $y \in -1 \boxplus b$, we have

$$(x \boxplus y) \cap (a \boxplus b) = (x \boxplus y) \cap (xb \boxplus -ay) = (a \boxplus b) \cap (xb \boxplus -ay).$$

Then

$$(x \boxplus y) \cap (a \boxplus b) = (x \boxplus y) \cap (xb \boxplus -ay) \subseteq xb \boxplus -ay,$$

$$(a \boxplus b) \cap (xb \boxplus -ay) = (x \boxplus y) \cap (xb \boxplus -ay) \subseteq x \boxplus y,$$

$$(x \boxplus y) \cap (xb \boxplus -ay) = (a \boxplus b) \cap (xb \boxplus -ay) \subseteq a \boxplus b.$$

(2) \Rightarrow (1): This is immediate by definition of strong Pathetic Cancellation. \square

Corollary 6.4. *For every skew hyperfield satisfying strong Pathetic Cancellation, we have*

$$1 \boxplus -1 \boxplus 1 \boxplus -1 = 1 \boxplus -1. \quad (23)$$

Proof. We first prove the direction (\subseteq). Let $f \in 1 \boxplus -1 \boxplus 1 \boxplus -1$. Then there exist x, y such that $x, y \in 1 \boxplus -1$ and $f \in x \boxplus y$. Let $a = -1$ and $b = 1$. Then $x \in 1 \boxplus a$ and $y \in -1 \boxplus b$. Then by Proposition 6.3,

$$x \boxplus y = (x \boxplus y) \cap (xb \boxplus -ay) \subseteq a \boxplus b = 1 \boxplus -1.$$

So $f \in x \boxplus y = 1 \boxplus -1$, and so

$$1 \boxplus -1 \boxplus 1 \boxplus -1 \subseteq 1 \boxplus -1.$$

Now we prove the direction (\supseteq). It is clear that

$$1 \boxplus -1 \subseteq 1 \boxplus -1 \boxplus 0 \subseteq 1 \boxplus -1 \boxplus 1 \boxplus -1.$$

So

$$1 \boxplus -1 \boxplus 1 \boxplus -1 = 1 \boxplus -1. \quad \square$$

6.2. Pathetic Cancellation for stringent skew hyperfields. In this section, we will show that the stringency implies the strong Pathetic Cancellation property and so implies Pathetic Cancellation. This helps to generalize the characterization of localization of strong matroids over stringent skew hyperfields.

Definition 6.5. [BS21] A skew hyperfield F is said to be **stringent** if for any $a, b \in F$, $a \boxplus b$ is a singleton whenever $a \neq -b$.

Fields, \mathbb{K} , and \mathbb{S} are all stringent, but \mathbb{P} does not satisfy stringency.

Lemma 6.6. [BS21] *Let R be a skew hyperfield and let G be a totally ordered group. Consider a short exact sequence of groups*

$$1 \rightarrow R^\times \xrightarrow{\varphi} H \xrightarrow{\psi} G \rightarrow 1,$$

where φ is the identity. Define x^h to be $h^{-1} \cdot x \cdot h$ for $x, h \in H$ and we extend this operation by setting $0_R^h := 0_R$. Assume that the short exact sequence **has stable sums**, that is, if for each $h \in H$ the operation $x \mapsto x^h$ is an automorphism of R .

Choose some object not in H , denoted by 0 . Define a multiplication \cdot on $H \cup \{0\}$ by $x \cdot y = 0$ if x or y is 0 and by the multiplication of H otherwise. Define a hyperaddition \boxplus on $H \cup \{0\}$ by taking 0 to be the additive identity and setting

$$x \boxplus y = \begin{cases} \{x\} & \text{if } \psi(x) > \psi(y), \\ \{y\} & \text{if } \psi(x) < \psi(y), \\ x(1 \boxplus_R x^{-1}y) & \text{if } \psi(x) = \psi(y) \text{ and } 0 \notin x(1 \boxplus_R x^{-1}y), \\ x(1 \boxplus_R x^{-1}y) \cup \psi^{-1}(\psi(x) \downarrow) & \text{if } \psi(x) = \psi(y) \text{ and } 0 \in x(1 \boxplus_R x^{-1}y). \end{cases}$$

Then the G -layering $R \rtimes_{H, \psi} G := (H \cup \{0\}, \boxplus, \cdot, 0, 1)$ of R along this short exact sequence is a skew hyperfield. If R is stringent, then so is $R \rtimes_{H, \psi} G$.

Theorem 6.7. [BS21] *Any skew stringent hyperfield has the form $R \rtimes_{H, \psi} G$, where R is either \mathbb{K} , or \mathbb{S} , or a skew field.*

Theorem 6.8. *Any stringent skew hyperfield satisfies strong Pathetic Cancellation and Pathetic Cancellation.*

Before showing Theorem 6.8, we will first introduce a useful lemma for any skew hyperfields.

Lemma 6.9. *Let F be a skew hyperfield and let $a, b \in F$. For any x, y in F with $x \in 1 \boxplus a$, $y \in -1 \boxplus b$, we have*

$$\begin{aligned} (x \boxplus y) \cap (a \boxplus b) &\neq \emptyset, \\ (x \boxplus y) \cap (xb \boxplus -ay) &\neq \emptyset, \end{aligned}$$

and

$$(a \boxplus b) \cap (xb \boxplus -ay) \neq \emptyset.$$

Proof. As $x \in 1 \boxplus a$ and $y \in -1 \boxplus b$, we have $1 \in x \boxplus -a$ and $-1 \in y \boxplus -b$. Thus

$$0 \in 1 \boxplus -1 \subseteq x \boxplus -a \boxplus y \boxplus -b = (x \boxplus y) \boxplus -(a \boxplus b).$$

So

$$(x \boxplus y) \cap (a \boxplus b) \neq \emptyset.$$

As $x \in 1 \boxplus a$ and $y \in -1 \boxplus b$, we have $xy \in y \boxplus ay$ and $-xy \in x \boxplus -xb$. Thus

$$0 \in xy \boxplus -xy \subseteq y \boxplus ay \boxplus x \boxplus -xb = (x \boxplus y) \boxplus -(xb \boxplus -ay).$$

So

$$(x \boxplus y) \cap (xb \boxplus -ay) \neq \emptyset.$$

As $x \in 1 \boxplus a$ and $y \in -1 \boxplus b$, we have $a \in -1 \boxplus x$ and $b \in 1 \boxplus y$. Then $ab \in -b \boxplus xb$ and $-ab \in -a \boxplus -ay$. Thus

$$0 \in ab \boxplus -ab \subseteq -b \boxplus xb \boxplus -a \boxplus -ay = -(a \boxplus b) \boxplus (xb \boxplus -ay).$$

So

$$(a \boxplus b) \cap (xb \boxplus -ay) \neq \emptyset.$$

□

Now we prove Theorem 6.8 by using the above lemma.

Proof of Theorem 6.8. Let $F = R \rtimes_{H, \psi} G$ be a stringent skew hyperfield. By Theorem 6.2, we only need to show that F satisfies strong Pathetic Cancellation. Let $a, b, x, y \in F^\times$ with $x \in 1 \boxplus a$ and $y \in -1 \boxplus b$. We need to show that

$$(a \boxplus b) \cap (x \boxplus y) \subseteq xb \boxplus -ay.$$

We will divide the proof into three cases.

Case 1: If $a = -1$ and $b = 1$, then $xb \boxplus -ay = x \boxplus y$. So

$$(a \boxplus b) \cap (x \boxplus y) \subseteq x \boxplus y = xb \boxplus -ay.$$

Case 2: If $a = -1$ and $b \neq 1$ or $a \neq -1$ and $b = 1$, then without loss of generality we may assume that $a = -1$ and $b \neq 1$. So by stringency, $-1 \boxplus b = \{y\}$. Then $a \boxplus b = -1 \boxplus b = \{y\}$. By Lemma 6.9,

$$a \boxplus b = \{y\} \subseteq x \boxplus y$$

and

$$a \boxplus b = \{y\} \subseteq xb \boxplus -ay.$$

So

$$(a \boxplus b) \cap (x \boxplus y) = \{y\} \subseteq xb \boxplus -ay.$$

Case 3: If $a \neq -1$ and $b \neq 1$, then $1 \boxplus a = \{x\}$ and $-1 \boxplus b = \{y\}$. So $a^{-1} \boxplus 1 = \{a^{-1} \cdot x\} = \{x \cdot a^{-1}\}$, and so $xa = ax$.

If $a \neq -b$, then $a \boxplus b = \{z\}$ for some $z \in F^\times$. By Lemma 6.9,

$$a \boxplus b = \{z\} \subseteq x \boxplus y$$

and

$$a \boxplus b = \{z\} \subseteq xb \boxplus -ay.$$

So

$$(a \boxplus b) \cap (x \boxplus y) = \{z\} \subseteq xb \boxplus -ay.$$

If $a = -b$, then $x = -y$. As $1 \boxplus a = \{x\}$, then $\psi(x) \geq 1_G$. So $\psi(ax) \geq \psi(a)$. Then

$$\begin{aligned} a \boxplus b &= a(1 \boxplus -1), \\ x \boxplus y &= x(1 \boxplus -1), \end{aligned}$$

and

$$xb \boxplus -ay = xa \boxplus -ax = ax \boxplus -ax = ax(1 \boxplus -1).$$

So

$$(a \boxplus b) \cap (x \boxplus y) \subseteq a(1 \boxplus -1) \subseteq ax(1 \boxplus -1) = xb \boxplus -ay.$$

So F satisfies strong Pathetic Cancellation and also Pathetic Cancellation. \square

From [BP19], we know the following theorem for matroids over stringent skew hyperfields.

Theorem 6.10. [BP19] *Any weak matroid over a stringent skew hyperfield is strong.*

Then we can get a similar characterization of extension for a strong matroid over a stringent skew hyperfield as for a weak matroid, and so Theorem 1.6 holds.

Next we would like to talk about the following important property for skew hyperfields.

Definition 6.11. A skew hyperfield F is **doubly distributive** if for any $a, b, c, d \in F$, $(a \boxplus b)(c \boxplus d) = ac \boxplus ad \boxplus bc \boxplus bd$.

Double distributivity is very important in matroid theory. Fields, \mathbb{K} , and \mathbb{S} are all doubly distributive. In [BS21], Bowler and Su showed that any doubly distributive skew hyperfield is stringent. So we will also get the following Theorem.

Theorem 6.12. *Let F be a doubly distributive skew hyperfield, let \mathcal{M} be a strong left (resp. right) F -matroid on E with F -cocircuit set $\mathcal{C}^*(\mathcal{M})$, and let*

$$\sigma : \mathcal{C}^*(\mathcal{M}) \rightarrow F$$

be a right (resp. left) F^\times -equivariant function.

Then the following statements are equivalent.

- (1) σ defines a strong single-element extension of \mathcal{M} .
- (2) σ defines a strong single-element extension of every rank 2 contraction of \mathcal{M} .
- (3) σ defines a strong single-element extension of every rank 2 minor of \mathcal{M} on three elements.

REFERENCES

- [AD12] Laura Anderson and Emanuele Delucchi. Foundations for a theory of complex matroids. *Discrete Comput. Geom.*, 48(4):807–846, 2012.
- [BB16] Matthew Baker and Nathan Bowler. Matroids over hyperfields. [arXiv:1601.01204](https://arxiv.org/abs/1601.01204), 2016.
- [BB19] Matthew Baker and Nathan Bowler. Matroids over partial hyperstructures. *Adv. Math.*, 343:821–863, 2019.
- [BLV78] Robert G. Bland and Michel Las Vergnas. Orientability of matroids. *J. Combinatorial Theory Ser. B.*, 24(1):94–123, 1978.
- [BLVS⁺99] Anders Björner, Michel Las Vergnas, Bernd Sturmfels, Neil White, and Günter M. Ziegler. *Oriented matroids*, volume 46 of *Encyclopedia of Mathematics and its Applications*. Cambridge University Press, Cambridge, second edition, 1999.
- [BP19] Nathan Bowler and Rudi Pendavingh. Perfect matroids over hyperfields. [arXiv:1908.03420](https://arxiv.org/abs/1908.03420), 2019.
- [BS21] Nathan Bowler and Ting Su. Classification of doubly distributive skew hyperfields and stringent hypergroups. *J. Algebra*, 574:669–698, 2021.
- [CR70] Henry H. Crapo and Gian-Carlo Rota. *On the foundations of combinatorial theory: Combinatorial geometries*. The M.I.T. Press, Cambridge, Mass.-London, preliminary edition, 1970.
- [Cra65] Henry H. Crapo. Single-element extensions of matroids. *J. Res. Nat. Bur. Standards Sect. B*, 69B:55–65, 1965.
- [Dre86] Andreas W. M. Dress. Duality theory for finite and infinite matroids with coefficients. *Adv. in Math.*, 59(2):97–123, 1986.
- [FL78] Jon Folkman and Jim Lawrence. Oriented matroids. *Journal of Combinatorial Theory, Series B*, 25(2):199 – 236, 1978.
- [Kra57] Marc Krasner. Approximation des corps valués complets de caractéristique $p \neq 0$ par ceux de caractéristique 0. In *Colloque d’algèbre supérieure, tenu à Bruxelles du 19 au 22 décembre 1956*, Centre Belge de Recherches Mathématiques, pages 129–206. Établissements Ceuterick, Louvain; Librairie Gauthier-Villars, Paris, 1957.

- [LV75] Michel Las Vergnas. Matroïdes orientables. *C. R. Acad. Sci. Paris Sér. A-B*, 280: Ai, A61–A64, 1975.
- [LV78] Michel Las Vergnas. Extensions ponctuelles d’une géométrie combinatoire orientée. In *Problèmes combinatoires et théorie des graphes (Colloq. Internat. CNRS, Univ. Orsay, Orsay, 1976)*, volume 260 of *Colloq. Internat. CNRS*, pages 265–270. CNRS, Paris, 1978.
- [Oxl92] James G. Oxley. *Matroid theory*. Oxford Science Publications. The Clarendon Press, Oxford University Press, New York, 1992.
- [Pen18] Rudi Pendavingh. Field extensions, derivations, and matroids over skew hyperfields. [arXiv:1802.02447](https://arxiv.org/abs/1802.02447), 2018.
- [Sta12] Richard P. Stanley. *Enumerative combinatorics. Volume 1*, volume 49 of *Cambridge Studies in Advanced Mathematics*. Cambridge University Press, Cambridge, second edition, 2012.
- [Su18] Ting Su. *Extensions of Matroids over Tracts and Doubly Distributive Partial Hyperfields*. PhD thesis, (Order No. 10973187, State University of New York at Binghamton), 2018. ProQuest Dissertations and Theses.
- [Su20] Ting Su. Matroids over skew tracts. [arXiv:2012.03253](https://arxiv.org/abs/2012.03253), 2020.
- [SW96] Charles Semple and Geoff Whittle. Partial fields and matroid representation. *Adv. in Appl. Math.*, 17(2):184–208, 1996.
- [Vir10] Oleg Viro. Hyperfields for tropical geometry i. hyperfields and dequantization. [arXiv:1006.3034v2](https://arxiv.org/abs/1006.3034v2), 2010.
- [Wel76] D. J. A. Welsh. *Matroid theory*. Academic Press [Harcourt Brace Jovanovich, Publishers], London-New York, 1976. L. M. S. Monographs, No. 8.

Email address: ting.su@uni-hamburg.de

DEPARTMENT OF MATHEMATICS, UNIVERSITÄT HAMBURG, GERMANY