

# COMPARING GRÖBNER BASES AND WORD REVERSING

MARC AUTORD

ABSTRACT. Gröbner bases, in their noncommutative version, and word reversing are methods for solving the word problem of a presented monoid, and both rely on iteratively completing the initial list of relations. Simple examples may suggest to conjecture that both completion procedures are closely related. Here we disprove this conjecture by exhibiting families of presentations for which they radically differ.

## INTRODUCTION

When an algebraic structure is given by generators and relations, typically a semigroup or a group, each element admits in general several word representatives. The word problem is the question of deciding whether two words represent the same element. It is known that, both in case of semigroups and groups, the word problem can be undecidable [7]. However a number of methods have been developed that solve the word problem in good cases. The aim of this paper is to compare two such methods, namely the well-known Gröbner basis method [9] as adapted to semigroups, and the word reversing method of [3]. Originally designed to answer questions in the context of free commutative algebras, the method of Gröbner bases has subsequently been adapted to noncommutative algebras and, *via* the inclusion of a semigroup  $G$  in the algebra  $K\langle S \rangle$ , to general semigroups. In the latter case, the method consists in starting with a semigroup presentation  $(\mathcal{S}; \mathcal{R})$  and in running a certain completion procedure that adds new relations that are consequences of the initial ones until one possibly obtains a so-called reduced Gröbner basis [8, 2] — see [9] for a survey.

Word reversing is another combinatorial method [3] for investigating presented semigroups. It also consists in iterating some simple syntactic transformation on words. In good cases, the method can be used to solve the word problem. However, this only happens when the initial presentation satisfies a certain completeness condition. When this is not the case, there exists a completion procedure that, as in the case of the Gröbner completion, consists in adding new relations to the initial presentation [5].

We thus have two *a priori* unrelated completion procedures. Now, it can be observed on some simple examples that the two processes lead to adding the same relations. It is therefore natural to address the question of how the two completions are connected. The aim of this paper is to show that, actually, there is no simple general relation:

**Proposition.** *There exist finite semigroup presentations for which the Gröbner completion and the reversing completion disagree.*

Actually, we shall prove a more precise statement—Proposition 3.1 below—showing really independent behaviours, namely examples where one completion is finite and the other is infinite, or where there is an inclusion or no inclusion.

Thus the paper is mainly composed of negative results and counter-examples. However, we think it is interesting to list these many examples because neither the Gröbner nor the reversing completion procedures have been much investigated so far, and their global behaviour is not well understood. Also, we point out that most of the examples we investigate below are not just artificial *ad hoc* constructions, but they involve well-known and interesting semigroups, in particular the braid semigroups and the Heisenberg semigroup: so, in particular, our results give explicit Gröbner bases for these cases.

The paper is organized as follows. In Section 1, we recall the notion of a Gröbner basis in the context of presented monoids. In Section 2, we similarly describe word reversing and its associated notion of completion and observe that the latter coincides with the Gröbner completion of Section 1 on simple examples. Then, in Section 3, we establish the main results by constructing explicit counter-examples witnessing all possible types of divergence for the two completions. In Section 4, we quit the word problem and address another problem involving presented semigroups, namely recognizing cancellativity, and we examine its possible connections with Gröbner bases.

**Acknowledgments.** The author is greatly indebted to Patrick Dehornoy for suggesting the problem and for his many helpful comments.

## 1. GRÖBNER BASES IN THE FRAMEWORK OF PRESENTED MONOIDS

Both in the commutative and noncommutative cases, Gröbner bases have been originally designed to decide whether a polynomial belongs to a given ideal of some algebra  $K[X_1, \dots, X_n]$  or  $K\langle X_1, \dots, X_n \rangle$ . It is however easy to adapt the Gröbner bases machinery so as to solve the word problem of presented semigroups.

In this section, we briefly review the method, in the specific case of semigroups. In particular, we recall how, in that case, the Gröbner completion procedure can be entirely performed in the language of semigroups, and how Gröbner bases can be used to solve the word problem.

**1.1. Gröbner bases.** Following standard notation, if  $\mathcal{S}$  is a nonempty set,  $\mathcal{S}^*$  denotes the free monoid generated by  $\mathcal{S}$ , *i. e.*, the set of all words on  $\mathcal{S}$  together with concatenation. The empty word is denoted by  $\varepsilon$ . In the sequel,  $\mathcal{R}$  is a set of pairs of nonempty words on  $\mathcal{S}$ . A pair  $(\mathcal{S}; \mathcal{R})$  is called a *semigroup presentation* and we call  $\mathcal{S}$  the set of *generators* and  $\mathcal{R}$  the set of *relations*. In the sequel, it will be convenient—in particular for Section 2—to work with monoids rather than semigroups, that is, to add a unit. We then define  $\langle \mathcal{S}; \mathcal{R} \rangle^+$  to be the monoid  $\mathcal{S}^*/\equiv$ , where  $\equiv$  is the smallest congruence on  $\mathcal{S}^*$  containing  $\mathcal{R}$ . We denote  $\equiv^{(1)}$  the relation so defined: “ $w \equiv^{(1)} w'$  holds if and only if going from  $w$  to  $w'$  can be done by applying one relation of  $\mathcal{R}$ ”.

For a field  $K$ , the free associative  $K$ -algebra (or simply free algebra) with set of generators  $\mathcal{S}$  and unity is denoted by  $K\langle \mathcal{S} \rangle$ . As a set it can be viewed as the set of all linear combinations of elements of  $\mathcal{S}^*$  with coefficients in  $K$ . The free monoid  $\mathcal{S}^*$  embeds in the free algebra  $K\langle \mathcal{S} \rangle$ , and, more generally, the monoid  $\langle \mathcal{S}; \mathcal{R} \rangle^+$  embeds

in the factor algebra  $K\langle\mathcal{S}\rangle/I$ , where  $I$  is the two-sided ideal generated by all the elements  $u - v$ , with  $(u, v) \in \mathcal{R}$ .

For details about Gröbner bases in the context of algebras we refer to [9], of which we follow the notation and the terminology. We fix a well-ordering  $<$  on the set of words  $\mathcal{S}^*$ , that is, any two words are comparable and every nonempty subset has a smallest element. This enables us to perform inductive proofs on the rank of words. Moreover, we assume that the ordering is compatible with the operation of the monoid:  $f < g$  implies  $ufv < ugv$  for all words  $u, v$ . Such an ordering is called *admissible*. There always exists an admissible ordering: for each linear ordering of  $\mathcal{S}$  the associated *deglex* ordering (or homogeneous lexicographic ordering) satisfies all these conditions: the words are first ordered by their length, and, if the lengths are the same, lexicographically. In the sequel, we shall often write  $u = v$  instead of  $(u, v)$  for relations of a presentation.

Adapting Gröbner techniques to the context of monoids—or semigroups—is easy, and it is alluded to in [8], but it seems not to have been written explicitly in literature, and, therefore, we include some details. The next proposition is the first step: equalities in a presented monoid  $\langle\mathcal{S}; \mathcal{R}\rangle^+$  correspond to equalities of monomials in the algebra  $K\langle\mathcal{S}\rangle/I$ , where  $I$  is an ideal determined by  $\mathcal{R}$ .

**Proposition 1.1.** *Assume  $(\mathcal{S}; \mathcal{R})$  is a semigroup presentation. Let  $I$  be the two-sided ideal of the free algebra  $K\langle\mathcal{S}\rangle$  generated by the elements  $u - v$  with  $(u, v) \in \mathcal{R}$ . Then, for all words  $w, w'$  on  $\mathcal{S}$ , the following are equivalent:*

- (i)  $w \equiv w'$ ,
- (ii)  $w - w' \in I$ .

*Proof.* Suppose  $w \equiv w'$ . This means that there exists a finite sequence of words  $w_0 = w, \dots, w_n = w'$  such that  $w_i \equiv^{(1)} w_{i+1}$  holds for every  $i < n$ . We prove by induction on  $n$  that  $w - w'$  lies in  $I$ . Assume  $n = 1$ ; there exist words  $t, u$  on  $\mathcal{S}$  and a relation  $v = v'$  of  $\mathcal{R}$  such that both  $w = tvu$  and  $w' = tv'u$  hold. By hypothesis,  $(v, v') \in \mathcal{R}$  implies  $v - v' \in I$  and hence  $t(v - v')u \in I$ , that is  $w - w' \in I$ . Assume  $n > 1$ . Then we have

$$w' = w_0 \equiv^{(1)} w_1 \equiv w_n = w.$$

By induction hypothesis we get  $w_n - w_1 \in I$  and  $w_1 - w_0 \in I$ , and, writing  $w - w' = (w_n - w_1) + (w_1 - w_0)$  shows that  $w - w'$  lies in  $I$ .

Suppose  $w - w' \in I$ . First observe that there is a decomposition  $w - w' = \sum_{i=1}^n t_i(v_i - v'_i)u_i$  for some  $t_i, u_i \in K\langle\mathcal{S}\rangle$  and  $(v_i, v'_i) \in \mathcal{R}$ ; this decomposition implies that there is a relation  $v = v'$  such that  $v$  is a subword of  $w$ , say  $w = tvu$ , with  $t, u \in \mathcal{S}^*$ . Therefore  $w - w' \in I$  implies  $w - w' - (tvu - tv'u) \in I$  and then  $tv'u - w' \in I$ . Suppose  $w > w'$  and that  $w$  is the smallest element for which the conclusion does not hold. Thus we get  $tv'u \equiv w'$ , hence  $w = tvu \equiv^{(1)} tv'u \equiv w'$ .  $\square$

With Proposition 1.1, we established a connection between words being equivalent and their difference lying in a particular ideal. The next lemma shows that for such ideals, that is to say ideals generated by differences of monomials, the elements of the reduced Gröbner basis are again differences of monomials.

**Lemma 1.2.** *Assume  $I$  is the ideal of  $K\langle\mathcal{S}\rangle$  generated by  $u_1 - v_1, \dots, u_n - v_n$  with  $u_i, v_i$  in  $\mathcal{S}^*$ . Then all the elements added during the  $G$ -completion have the type  $u - v$ , with  $u$  and  $v$  in  $\mathcal{S}^*$ .*

*Proof.* Three steps are involved in the algorithm, namely normalization, reduction and completion.

Define  $\mathcal{B}$  to be the set of the elements  $u_i - v_i$ ,  $1 \leq i \leq n$ . The normalization process consists in substituting every element of  $\mathcal{B}$  with a proportional element with leading coefficient 1. In our context, this step does not change any of the elements of  $\mathcal{B}$ .

In the sequel, if  $p$  is a polynomial,  $\hat{p}$  denotes the term of highest rank and  $\check{p}$  denotes  $p - \hat{p}$ . Assume  $t \in \mathcal{B}$ . Suppose there is a  $u$  in  $\mathcal{B}$  such that  $\hat{u}$  is a subword of  $\hat{t}$ ; in other words, there are words  $t_l$  and  $t_r$  satisfying  $\hat{t} = t_l \hat{u} t_r$ . Then the reduction step consists in discarding  $t$  from  $\mathcal{B}$  and replacing it by  $t - t_l \hat{u} t_r$ . We check now that  $t - t_l \hat{u} t_r$  has the prescribed type:

$$t - t_l \hat{u} t_r = (\hat{t} - t_l \hat{u} t_r) - \check{t} + t_l \check{u} t_r = t_l \check{u} t_r - \check{t}.$$

The third step is composition, which forces leading terms to collapse when appropriately combined. Given  $u = xy - \check{u}$  and  $v = yz - \check{v}$ , the composition is  $uz - xv$ , in which the two leading terms  $xy$  and  $yz$  cancel. Now we have  $uz - xv = x\check{v} - \check{u}z$ , again a difference of two monomials.  $\square$

Thus, along the G-completion, *i. e.*, the computation of the Gröbner basis, the elements added to the basis are differences of monomials. By Proposition 1.1, they correspond to equalities in the monoid  $\langle \mathcal{S}; \mathcal{R} \rangle^+$  and therefore to equivalent words on  $\mathcal{S}$ . This allows us to redefine the Gröbner operations at the level of words directly:

**Definition 1.3** (reduction of a relation). Let  $(\mathcal{S}; \mathcal{R})$  be a semigroup presentation. Let  $(w, w')$  and  $(v, v')$  be relations satisfying  $v > v'$  and  $w = v_l v v_d$ , with  $v_l, v_d \in \mathcal{S}^*$ . Then the relation  $(v_l v' v_r, w')$  is said to be obtained by *reduction* of  $(w, w')$  by  $(v, v')$ . We say that the relation  $(w, w')$  *reduces to 0* with respect to the set  $\mathcal{R}$ , or simply, when the set of relations is clear from the context, that  $(w, w')$  reduces to 0, if there is a sequence of relations  $(w, w') = (w_0, w'_0), \dots, (w_n, w'_n) = (u, u)$  of  $\equiv$  such that every  $(w_{i+1}, w'_{i+1})$  is a reduction of  $(w_i, w'_i)$  by a relation  $(u_i, u'_i)$  of  $\mathcal{R}$ .

Note that a reduction of  $w = w'$  by any relation yields a relation  $z = z'$  that satisfies  $z < w$  or  $z' < w'$ . Since  $\mathcal{S}^*$  is well-ordered, reducing iteratively a relation eventually stops; otherwise we would get an infinite decreasing sequence of words. When no reduction applies to a relation, it is said to be *reduced*.

**Definition 1.4** (composition of relations). Let  $(\mathcal{S}; \mathcal{R})$  be a semigroup presentation. Let  $w = w'$  and  $v = v'$  be relations in  $\mathcal{R}$  such that  $w$  and  $v$  overlap, *i. e.*, we have  $w = xy$  and  $v = yz$  with  $y$  a nonempty word. The *composition* of  $w = w'$  and  $v = v'$  with overlapping  $y$  is the element  $(xv', w'z)$  of  $\mathcal{S}^* \times \mathcal{S}^*$ .

**Fact 1.5.** *The composition of two elements of  $\equiv$  is again in  $\equiv$ .*

*Remark 1.6.* To compute the composition of  $(xy, w')$  and  $(yz, v')$  with overlapping  $y$ , we write

$$(xy - w')z - x(yz - v') = xv' - w'z$$

and we deduce that the composition is  $(xv', w'z)$ . This convenient way of composing relations is in fact the way of composing polynomials in algebras.

Adapting the classical notions—see for instance [9]—we introduce:

**Definition 1.7** (Gröbner basis and G-completeness). Let  $(\mathcal{S}; \mathcal{R})$  be a semigroup presentation. A subset  $\mathcal{B}$  of the congruence  $\equiv$  generated by  $\mathcal{R}$  is a *Gröbner basis* of  $(\mathcal{S}; \mathcal{R})$  if every element  $(u, v)$  of  $\mathcal{B}$  satisfies  $u > v$  and if, for any two equivalent words  $w, w'$  in  $\mathcal{S}^*$  with  $w > w'$ , there exists an element  $(u, v)$  in  $\mathcal{B}$  such that  $u$  is a subword of  $w$ . If  $\mathcal{R}$  is a Gröbner basis, the presentation is said to be *G-complete*.

Not every presentation is G-complete: in the monoid associated to the presentation  $(a, b; abababa = bb)$  with homogeneous lexicographic order, the words  $b^3a$  and  $ab^3$  are equivalent and yet none of them admits  $abababa$  as a subword.

Nevertheless, Gröbner bases do exist: starting from  $(\mathcal{S}; \mathcal{R})$ , complete the set of relations with every equality  $u = v$  that holds in  $\langle \mathcal{S}; \mathcal{R} \rangle^+$ . The set of relations obtained this way is a Gröbner basis but there is no practical interest of such a completion as it is noneffective: it requires a former solution to the word problem. Moreover, there is redundancy in such a basis in the sense that if  $u = v$  is a relation, then  $wu = wv$  is also a relation and both appear in the basis, although  $wu = wv$  can be reduced by  $u = v$ . We shall see in the sequel, however, that running Algorithm 1.11 completes the set of relations into a smaller Gröbner basis than the set of all relations, that it does not need a solution to the word problem and that no redundancy is left in the Gröbner basis so obtained, *i. e.*, the Gröbner basis is reduced.

**Definition 1.8.** A Gröbner basis is *minimal* if no subset of it is a Gröbner basis. A set of relations  $\mathcal{U}$  is *reduced* if every relation of the presentation is reduced.

*Remark 1.9.* A set  $\mathcal{U}$  of relations in which there exist two relations involving the same leading word is not reduced: if  $u = v$  and  $u = w$  are two relations of  $\mathcal{U}$  satisfying  $v < w$ , one reduces  $u = v$  by  $u = w$  to  $w = v$  and then  $u = w$  to  $u = v$ .

To recognize whether a set of relations is a reduced Gröbner basis, we have the following criterion:

**Proposition 1.10.** *Assume  $(\mathcal{S}; \mathcal{R})$  is a semigroup presentation and  $\mathcal{U}$  a set satisfying  $\mathcal{R} \subseteq \mathcal{U} \subseteq \equiv$ . If  $\mathcal{U}$  is reduced and if every composition of two relations of  $\mathcal{U}$  reduces to 0, then  $\mathcal{U}$  is a reduced Gröbner basis of  $(\mathcal{S}; \mathcal{R})$ .*

*Proof.* The result is a rewriting of Lemma on Composition [9, p. 30] adapted to the context of monoids using Proposition 1.1.  $\square$

The conjunction of Proposition 1.1 and Lemma 1.2 give an algorithm (based on the one working in the free algebras) that computes a reduced Gröbner basis for a semigroup presentation. There are no references to algebras nor to ideals either, the whole process taking place in the monoid. In a reduced set of relations, we order pairs by putting

$$(u_1 = v_1, u_2 = v_2) < (u_3 = v_3, u_4 = v_4) \Leftrightarrow u_1u_2 < u_3u_4.$$

Since the set of relations is reduced, the order  $<$  is linear.

**Algorithm 1.11** (G-completion). *Assume  $(\mathcal{S}; \mathcal{R})$  is a presentation. Start with  $\mathcal{U} = \mathcal{R}$ .*

1. Reduce all the relations of  $\mathcal{U}$  until no possible reduction is left;
2. Delete all relations  $v = v$  of  $\mathcal{U}$ ;
3. WHILE there exist two relations of  $\mathcal{U}$  that can be composed  
Add the result of composition of the smallest pair to  $\mathcal{U}$ ;

Go to 1;

OUTPUT :  $\mathcal{U}$ .

**Proposition 1.12.** *If Algorithm 1.11 terminates, the final set of relations  $\mathcal{U}$  is a reduced Gröbner basis of  $(\mathcal{S}; \mathcal{R})$ .*

*Proof.* The set of relations  $\mathcal{U}$  eventually obtained fulfills the conditions of Proposition 1.10.  $\square$

Algorithm 1.11 need not terminate in a finite number of steps. In fact, as we will see in Section 1.3, whenever G-completion stops, we can solve the word problem. Conversely, if  $(\mathcal{S}; \mathcal{R})$  is a presentation for a semigroup with undecidable word problem—and such presentations exist—then the execution of Algorithm 1.11 on  $(\mathcal{S}; \mathcal{R})$  cannot terminate. But we shall see below that this may also happen for presentations of semigroups with an easy word problem.

**1.2. An example.** We now illustrate Algorithm 1.11 by computing a reduced Gröbner basis explicitly. This example also shows that Algorithm 1.11 may not terminate.

**Example 1.13.** Consider the presentation  $(a, b; bab = ba^2)$  and the deglex ordering induced by  $b > a$ . Following Algorithm 1.11, we alternatively perform reduction steps and composition steps. A reduction by the relation numbered  $(i)$  will be denoted  $\overset{(i)}{\rightsquigarrow}$ . We start with  $\mathcal{U} = \{bab = ba^2\}$  and we number (1) the relation  $bab = ba^2$ .

Since there is no reduction at this stage, we first compose (1) with itself to get:

$$(bab - ba^2)ab - ba(bab - ba^2) = -ba^2ab + bab^2 \overset{(1)}{\rightsquigarrow} -ba^3b + a^4b,$$

that is, the relation

$$(2) \quad ba^3b = a^4b.$$

Thus we obtain  $\mathcal{U}_1 = \{bab = ba^2, ba^3b = a^4b\}$ . There is no reduction since  $bab$  is not a subword of  $ba^3b$ . Composing (2) with (1), we get:

$$(ba^3b - a^4)ab - ba^3(bab - ba^2) = -ba^4ab + ba^3ba^2 \overset{(2)}{\rightsquigarrow} -ba^5b + a^6b,$$

and therefore the relation

$$(3) \quad ba^5b = a^6b.$$

We obtain  $\mathcal{U}_2 = \{bab = ba^2, ba^3b = a^4, ba^5b = a^6\}$ . We claim that the algorithm successively adds all relations

$$(n) \quad ba^{2n-1}b = a^{2n}b.$$

We prove it by induction on  $n$ . The case  $n = 1$  is clear. Suppose  $n > 1$  and compose relation  $(n)$  with relation (1) to get  $(n+1)$ :

$$\begin{aligned} (ba^{2n-1}b - a^{2n})ab - ba^{2n-1}(bab - ba^2) \\ &= -ba^{2n}ab + ba^{2n+1}ba^2 \\ &\overset{(n)}{\rightsquigarrow} -ba^{2(n+1)-1}b + ba^{2n+2} \\ &= -ba^{2(n+1)-1}b + ba^{2(n+1)}. \end{aligned}$$

Hence we obtain  $\mathcal{U}_\infty = \{ba^{2n-1}b = a^{2n}; n \geq 1\}$ . We claim that  $\mathcal{U}_\infty$  is a reduced Gröbner basis of the presentation  $(a, b; bab = ba^2)$ . By Proposition 1.10, it suffices

to check that all compositions in  $\mathcal{U}_\infty$  reduce to 0. Now the composition of  $(n)$  and  $(m)$  is:

$$\begin{aligned} (ba^{2n-1}b - ba^{2n})a^{2m-1}b - ba^{2n-1}(ba^{2m-1}b - ba^{2m}) \\ &= -ba^{2n}a^{2m-1}b + ba^{2n-1}ba^{2m} \\ &\stackrel{(n)}{\rightsquigarrow} -ba^{2(m+n)-1}b + a^{2(m+n)}b \\ &\stackrel{(m+n)}{\rightsquigarrow} -ba^{2(m+n)} + ba^{2(m+n)} = 0. \end{aligned}$$

So there is no reduction and no composition left in  $\mathcal{U}_\infty$ . Thus, the set  $\mathcal{U}_\infty$  is a reduced Gröbner basis.

**1.3. Using Gröbner bases.** In this section, we recall that the knowledge of a Gröbner basis of a semigroup presentation allows to solve the word problem of the associated monoid.

**Definition 1.14.** Let  $(\mathcal{S}; \mathcal{R})$  be a G-complete semigroup presentation. A word  $u$  of  $\mathcal{S}^*$  is *G-reduced* (or simply *reduced*) if none of its subwords appears in a relation of  $\mathcal{R}$  as a leading word. The *G-reduction* of a word  $u$  of  $\mathcal{S}^*$  is the G-reduced word  $\underline{u}$   $\mathcal{R}$ -equivalent to  $u$ .

*Remark 1.15.* The unicity of G-reduction follows from the properties of Gröbner bases: let  $\underline{u}$  and  $\underline{u}'$  be two G-reductions of a word  $u$ ; the equivalence  $\underline{u} \equiv \underline{u}'$  implies that there exists a relation  $v = v'$  in  $\mathcal{R}$ , with  $v$  a subword of  $\max(\underline{u}, \underline{u}')$ , contradicting the hypothesis that both words were reduced.

G-reduction provides a unique normal form for each element of the considered monoid, and therefore solves the word problem:

**Proposition 1.16.** *Assume that  $(\mathcal{S}; \mathcal{R})$  is a G-complete presentation. Then two words  $w, w'$  of  $\mathcal{S}^*$  represent the same element of  $\langle \mathcal{S}; \mathcal{R} \rangle^+$  if and only if the reductions of  $w$  and  $w'$  are equal.*

**Example 1.17.** With the setting of Section 1.2, the word  $aba^3$  is G-reduced; the word  $aba^3bab$  is not reduced however, since both  $ba^3b$  and  $bab$  appear in  $\mathcal{U}_\infty$  as leading words of relations, namely  $ba^3b = ba^4$  and  $bab = ba^2$ . To reduce  $aba^3bab$ , we substitute, for example, the subword  $ba^3b$  with  $ba^4$  to get  $aba^5b$  and then  $ba^5b$  with  $ba^6$  to obtain the G-reduced word  $aba^6$  equivalent to  $aba^3bab$ . Starting the reduction with the relation  $bab = ba^2$  instead yields  $aba^3ba^2$  and then reducing with the relation  $ba^3b = ba^4$ , we get again the reduced word  $aba^6$ .

## 2. WORD REVERSING

Word reversing is a combinatorial operation on words that also solves the word problem for a presented monoid whenever the considered presentation satisfies an *ad hoc* condition called completeness. Not every presentation is complete for reversing, but, as in the case of Gröbner bases, there exists a completion procedure that possibly transforms an initially incomplete presentation into a complete one.

**2.1. Word reversing.** We recall results about word reversing (and refer to [5] for more details) so as to be able to compare this technique with the Gröbner methods exposed in Section 1.1.

Let  $(\mathcal{S}; \mathcal{R})$  be a semigroup presentation. For every letter  $s$  in  $\mathcal{S}$ , we introduce a disjoint copy  $s^{-1}$  of  $s$  and we denote by  $\mathcal{S}^{-1}$  the set of all  $s^{-1}$ 's. The elements

of  $\mathcal{S}$  (resp.  $\mathcal{S}^{-1}$ ) are said to be *positive* (resp. *negative*). For  $s_1, \dots, s_n \in \mathcal{S}$  and  $u = s_1 \dots s_n$  a word in  $\mathcal{S}^*$ , we write  $u^{-1}$  for the word  $s_n^{-1} \dots s_1^{-1}$  in  $\mathcal{S}^{-1*}$ .

**Definition 2.1** (reversing). Let  $(\mathcal{S}; \mathcal{R})$  be a semigroup presentation and let  $w$  and  $w'$  be words on  $\mathcal{S} \cup \mathcal{S}^{-1}$ . We say that  $w \curvearrowright^{(1)} w'$  is true if  $w'$  is obtained from  $w$

- either by deleting a subword  $u^{-1}u$  with  $u \in \mathcal{S}^+$ ,
- or by replacing a subword  $u^{-1}v$  where  $u, v$  are nonempty words on  $\mathcal{S}$  with a word  $v'u'^{-1}$  such that  $uv' = vu'$  is a relation of  $\mathcal{R}$ .

We say that  $w$  is *reversible* to  $w'$ , and we write  $w \curvearrowright w'$ , if there exists a sequence of words  $w_0, w_1, \dots, w_n$  satisfying  $w_i \curvearrowright^{(1)} w_{i+1}$  for every  $i$  and  $w = w_0$  and  $w' = w_n$ . We say in that case that  $w'$  is a *reversing* of  $w$ .

**Example 2.2.** Take the standard Artin presentation  $(a, b; bab = aba)$  and start with the word  $a^{-1}b^2$ : we successively get

$$a^{-1}b^2 \curvearrowright bab^{-1}a^{-1}b \curvearrowright bab^{-1}bab^{-1}a^{-1} \curvearrowright ba\varepsilon ab^{-1}a^{-1} = baab^{-1}a^{-1}.$$

Note that reversing sequences need not terminate. We say that word reversing is *convergent* if, starting from any word, there exists a terminating reversing sequence. The presentation above is convergent, whereas  $(a, b; ba = a^2b)$  is not:

$$b^{-1}ab \curvearrowright ab^{-1}a^{-1}b \curvearrowright ab^{-1}aba^{-1}.$$

The next proposition exhibits a link between  $\curvearrowright$  and  $\equiv$ .

**Proposition 2.3** ([5, Prop. 1.9]). *Assume that  $(\mathcal{S}; \mathcal{R})$  is a semigroup presentation, and  $u, v$  are words in  $\mathcal{S}^*$ . Then  $u^{-1}v \curvearrowright \varepsilon$  implies  $u \equiv v$ .*

The converse is not true in general: there exist presentations for which word reversing fails to detect equivalence and thus does not solve the associated word problem; these presentations lack the completeness property, which we define as follows.

**Definition 2.4** (R-completeness). A semigroup presentation is *R-complete* if  $u \equiv v$  implies  $u^{-1}v \curvearrowright \varepsilon$ .

By very definition, we have

**Proposition 2.5.** *Assume that  $(\mathcal{S}; \mathcal{R})$  is a R-complete presentation such that  $\mathcal{R}$ -word reversing is convergent. Then two words  $w, w'$  of  $\mathcal{S}^*$  represent the same element of  $\langle \mathcal{S}; \mathcal{R} \rangle^+$  if and only if  $w^{-1}w' \curvearrowright \varepsilon$  holds.*

In the sequel, we shall need a criterion for establishing whether a presentation is possibly R-complete. We shall use the one we describe now.

**Definition 2.6** (homogeneity). We say that a positive presentation  $(\mathcal{S}; \mathcal{R})$  is *homogeneous* if it admits a *pseudolength*, the latter being defined as a map  $\lambda$  of  $\mathcal{S}^*$  to the nonnegative integers, satisfying  $\lambda(su) > \lambda(u)$  for each  $s$  in  $\mathcal{S}$  and  $u$  in  $\mathcal{S}^*$ , and invariant under  $\equiv$ .

Note that if all pairs in  $\mathcal{R}$  have the same length then the length itself is a pseudolength for  $(\mathcal{S}; \mathcal{R})$ . We state now a criterion to check R-completeness:

**Algorithm 2.7.** *Let  $(\mathcal{S}; \mathcal{R})$  be a homogeneous semigroup presentation. For each triple of letters  $s, t, r$  in  $\mathcal{S}$ :*



1. Reverse  $s^{-1}rr^{-1}t$  to all possible words of the form  $uv^{-1}$ , with  $u, v \in \mathcal{S}^*$ ;
2. For each  $uv^{-1}$  so obtained, check  $(su)^{-1}(tv) \curvearrowright \varepsilon$ .

**Proposition 2.8** ([5, Algorithm 4.8]). *Assume that  $(\mathcal{S}; \mathcal{R})$  is a semigroup homogeneous presentation. Then  $(\mathcal{S}; \mathcal{R})$  is R-complete if and only if the answer at Step 2 of Algorithm 2.7 is positive for each triple of letters  $(r, s, t)$  and each word  $uv^{-1}$  obtained at Step 1.*

**2.2. Reversing-completion.** When a presentation is not R-complete, *i. e.*, when word reversing fails to prove some equivalence  $u \equiv v$ , there are completion procedures, in particular when the presentation is homogeneous:

**Algorithm 2.9.** *The setting is the one of Algorithm 2.7.*

REPEAT

Reverse  $s^{-1}rr^{-1}t$  to all possible words of the form  $uv^{-1}$ ;

FOR each  $uv^{-1}$  so obtained:

IF  $(su)^{-1}(tv) \not\curvearrowright \varepsilon$

THEN add the relation  $su = tv$  to the presentation;

UNTIL no new relation has been added to the presentation;

OUTPUT : a presentation.

**Proposition 2.10** ([5, § 5]). *When Algorithm 2.9 terminates, it yields a R-complete presentation.*

Algorithm 2.9 and Proposition 2.10 are comparable to Algorithm 1.11 and Proposition 1.12 in the sense that if the considered presentation fails at a completeness test, namely  $(su)^{-1}tv \curvearrowright \varepsilon$  for word reversing and whether it exists compositions not reducing to 0 for Gröbner, then both algorithms add the obstruction to the presentation.

**2.3. An example.** In this section, we apply Algorithms 2.7 and 2.9 to the example of Section 1.2. We first have to check whether the presentation  $(a, b; bab = ba^2)$  is R-complete and then, if needed, R-complete it.

In this case, the length of a word is invariant under  $\equiv$  and is therefore a pseudolength; hence the presentation is homogeneous and we can apply Algorithm 2.9. There are eight triples of letters to deal with but as no relation of the presentation is of the type  $a\dots = b\dots$ , we are left with a single triple, namely  $(b, b, b)$ .

Before reversing  $b^{-1}bb^{-1}b$ , we introduce the notion of reversing graph and refer to [6] for more details. A reversing graph is a directed and labelled graph that we associate to a reversing sequence  $w_0, w_1, \dots$  as follows. First, we associate with  $w_0$  a path labelled with the successive letters of  $w_0$ : we associate to every positive letter  $s$  an horizontal right-oriented edge labelled  $s$ , and to every negative letter  $s^{-1}$  a vertical down-oriented edge labelled  $s$ . Then we successively represent the words  $w_1, w_2, \dots$  as follows: if  $w_{i+1}$  is obtained from  $w_i$  by replacing  $u^{-1}v$  with  $v'u'^{-1}$  (such that  $uv' = vu'$  is a relation of the considered presentation), then the involved factor  $u^{-1}v$  is associated with a diverging pair of edges in a path labelled  $w_i$  and we complete the graph by closing the open pattern  $u^{-1}v$  using right-oriented edges labelled  $v'$  and down-oriented edges labelled  $u'$ , see Fig. 1.

The case of the empty word  $\varepsilon$ , which appears when a factor  $u^{-1}u$  is deleted or some relation  $uv' = v$  is used, is treated similarly: we introduce  $\varepsilon$ -labelled edges and use them according to the conventions  $\varepsilon^{-1}u \curvearrowright u\varepsilon^{-1}$ ,  $u^{-1}\varepsilon \curvearrowright \varepsilon u^{-1}$ , and  $\varepsilon^{-1}\varepsilon \curvearrowright \varepsilon\varepsilon^{-1}$ .

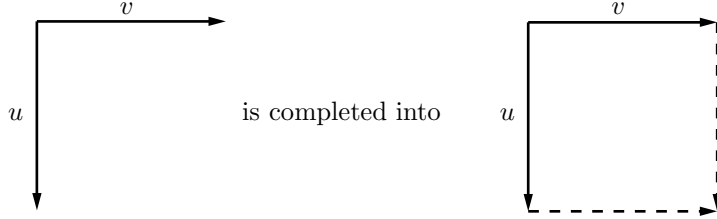

FIGURE 1. Reversing of  $u^{-1}v$  into  $v'u'^{-1}$ .

The word that is being reversed along the reversing sequence appears on the graph as the top left border: concatenate the labels of the top left border (with the convention that an arrow crossed backwards contributes with an exponent  $-1$ ) to get the word. See Fig. 2 for a simple example of reversing graph.

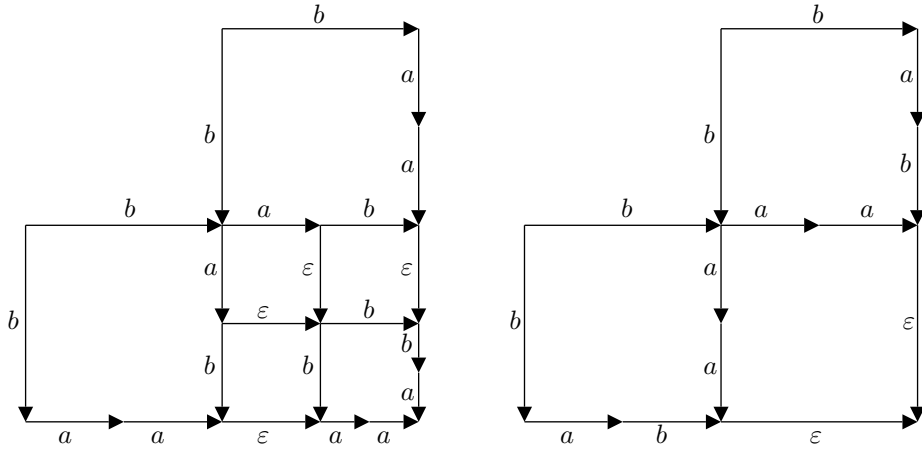

FIGURE 2. Case of the presentation  $(a, b; bab = ba^2)$ , reversing of  $b^{-1}bb^{-1}b$ . Because the relation  $bab = ba^2$  is of the type  $b\dots = b\dots$ , the reversing of  $b^{-1}bb^{-1}b$  is not deterministic: at each reversing step of the type  $b^{-1}b$ , one can either delete the subword  $b^{-1}b$  or replace it with  $aba^{-2}$ . Among the possible reversings, we only consider those of the form  $b^{-1}bb^{-1}b \curvearrowright uv^{-1}$  in order to apply Proposition 2.10.

Now we use reversing graphs to study the R-completeness of the presentation  $(a, b; bab = ba^2)$ . The word  $b^{-1}bb^{-1}b$  reverses into  $a^4(a^3b)^{-1}$  and  $a^2(ab)^{-1}$ , and, symmetrically, into  $a^3b(a^4)^{-1}$  and  $ab(a^2)^{-1}$  (Fig. 2). Hence, according to Algorithm 2.7, we have to check  $(ba^4)^{-1}ba^3b \curvearrowright \varepsilon$  and  $(ba^2)^{-1}bab \curvearrowright \varepsilon$  (the symmetric cases are similar). Since  $bab = ba^2$  is a relation of the presentation,  $(ba^2)^{-1}bab \curvearrowright \varepsilon$  trivially holds.

As for  $(ba^4)^{-1}ba^3b$ , Fig. 3 shows that it cannot be reversed to  $\varepsilon$ . Indeed, there is no relation of the type  $a\dots = b\dots$  in the presentation, therefore the words  $(a^2b)^{-1}a^3$  and  $a^{-1}b$  cannot be reversed. Hence, by Proposition 2.8, the presentation

is not R-complete, and, applying Algorithm 2.9, we add the relation  $ba^4 = ba^3b$  to the presentation.

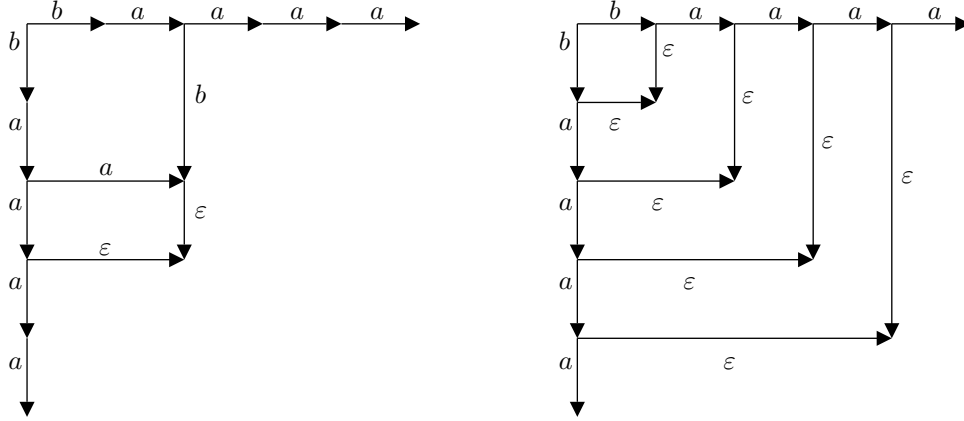

FIGURE 3. Case of the presentation  $(a, b; bab = ba^2)$ , reversing of  $(ba^4)^{-1}ba^3b$ : despite the equivalence  $ba^4 \equiv ba^3b$ , the word  $(ba^4)^{-1}ba^3b$  does not reverse to  $\varepsilon$ . The relation  $ba^4 = ba^3b$  is therefore added to the presentation so that this equivalence is now provable in terms of reversing.

We prove now, by induction on  $n$ , that the presentation  $(a, b; bab = a^2b, \dots, ba^{2n-1}b = ba^{2n})$  is not R-complete and that Algorithm 2.9 leads to adding the relation  $ba^{2n+1}b = ba^{2n+2}$ . The case  $n = 1$  was treated above. Assume  $n \geq 2$ . As illustrated in Fig. 4,  $b^{-1}bb^{-1}b$  reverses to  $a^{2n}(a^{2n-1}b)^{-1}$  and  $(ba^{2n+2})^{-1}ba^{2n+1}b$  does not reverse to  $\varepsilon$ , so the criterion of Proposition 2.8 fails, and, according to Algorithm 2.9, we add  $ba^{2n+1}b = ba^{2n+2}$ .

We claim now that the presentation  $(a, b; ba^{2n-1}b = ba^{2n}, n \geq 1)$  is R-complete. To prove this, as we have seen above, we reverse the word  $b^{-1}bb^{-1}b$  to all possible words of the form  $uv^{-1}$ , as required by the completeness criterion (Algorithm 2.7). Thus, for any  $m < n$ , we have the following sequence of reversings:

$$\begin{aligned} b^{-1}bb^{-1}b &\curvearrowright^{(1)} a^{2n}b^{-1}(a^{2n-1})^{-1}b^{-1}b &&\curvearrowright^{(1)} a^{2n}b^{-1}(a^{2n-1})^{-1}a^{2m-1}b(a^{2m})^{-1} \\ &&&\curvearrowright^{(1)} a^{2n}b^{-1}(a^{2(n-m)})^{-1}b(a^{2m})^{-1}. \end{aligned}$$

From the latter word, unless  $m = n$  holds and because there is no relation  $a \dots = b \dots$ , there cannot be a reversing of  $b^{-1}bb^{-1}b$  to a word of the type  $uv^{-1}$ . Suppose we have  $m = n$ , then for every  $p$  we get

$$\begin{aligned} b^{-1}bb^{-1}b &\curvearrowright^{(1)} a^{2m}b^{-1}b(a^{2m})^{-1} &&\curvearrowright^{(1)} a^{2m}a^{2p}b^{-1}(a^{2p-1})^{-1}(a^{2m})^{-1} \\ &&&\curvearrowright^{(1)} a^{2(m+p)}b^{-1}(a^{2(p+m)-1})^{-1}. \end{aligned}$$

Now, since  $ba^{2(p+m)} = ba^{2(p+m)-1}b$  is a relation of the presentation, the criterion for R-completeness is satisfied (Algorithm 2.7), which proves that the presentation  $(a, b; ba^{2n-1}b = ba^{2n}, n \geq 1)$  is R-complete. So we can conclude with:

**Fact 2.11.** *Starting with the presentation  $(a, b; bab = ba^2)$ , both the G-completion and the R-completion lead to adding the (infinite) family of relations  $ba^{2n-1}b = ba^{2n}$  with  $n \geq 2$ .*

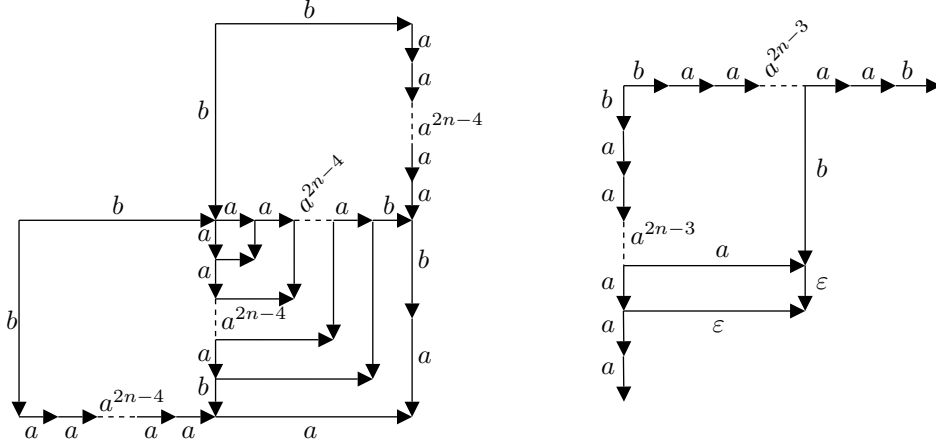

FIGURE 4. Reversing of the word  $b^{-1}bb^{-1}b$  to  $a^{2n+2}(a^{2n+1}b)^{-1}$ , using relations added to the presentation  $(a, b; bab = ba^2)$ . The word  $(ba^{2n+2})^{-1}ba^{2n+1}b$  does not reverse to  $\varepsilon$  since no relation of the type  $b\dots = a\dots$  has been added so far.

Other simple presentations, such as  $(a, b; a^2b = ba^2, ba^2 = a^2b)$  or the Baumslag-Solitar presentations  $(a, b; ba = a^nb)$ , give rise to a similar coincidence phenomenon. So it is natural to raise

**Question 2.12.** *Do the  $G$ -completion and the  $R$ -completion necessarily coincide for every semigroup presentation?—or, at least, on every presentation in some natural family?*

### 3. DIVERGENCE RESULTS

In this section, we answer Question 2.12 in the negative:

**Proposition 3.1.** *There exist finite semigroup presentations for which the  $G$ -completion and the  $R$ -completion do not agree. More precisely, using  $\widehat{\mathcal{R}}^G$  (resp.  $\widehat{\mathcal{R}}^R$ ) for the  $G$ -completion (resp. the  $R$ -completion), there exist finite semigroup presentations  $(\mathcal{S}; \mathcal{R})$  exhibiting each of the following behaviours:*

- type 1:  $\widehat{\mathcal{R}}^R$  is a proper subset of  $\widehat{\mathcal{R}}^G$ , with  $\widehat{\mathcal{R}}^R$  finite and  $\widehat{\mathcal{R}}^G$  infinite;
- type 1':  $\widehat{\mathcal{R}}^R$  is a proper subset of  $\widehat{\mathcal{R}}^G$ , with both  $\widehat{\mathcal{R}}^R$  and  $\widehat{\mathcal{R}}^G$  finite;
- type 2:  $\widehat{\mathcal{R}}^G$  is a proper subset of  $\widehat{\mathcal{R}}^R$ , with  $\widehat{\mathcal{R}}^G$  finite and  $\widehat{\mathcal{R}}^R$  infinite;
- type 3:  $\widehat{\mathcal{R}}^G$  and  $\widehat{\mathcal{R}}^R$  are not comparable with respect to inclusion.

We shall now successively construct examples displaying the various above-mentioned behaviours.

**3.1. Type 1 counter-examples.** It is relatively easy to find type 1 counter-examples, and we shall exhibit various families.

**Proposition 3.2.** *Every presentation*

$$(3.1) \quad (a, b, c, \dots; bwb = abw), \quad w \in \{a, b, c, \dots\}^*$$

*together with any homogeneous lexicographic order with  $a$  minimal is a type 1 counter-example.*

*Proof.* Let  $\Pi_w$  be the presentation of (3.1). Each presentation  $\Pi_w$  is homogeneous (the length is a pseudolength) and has exactly one relation, which is of the type  $a\dots = b\dots$ ; by Proposition 2.8, the presentation  $\Pi_w$  is R-complete.

First, consider the case  $w = \varepsilon$ . Then the composition of  $bb = ab$  with itself iteratively leads to the relations  $R_m : ba^m b = a^{m+1}b$ . Now the composition of  $R_m$  with  $R_n$  reduces to 0. Proposition 1.10 implies that  $\{ba^m b = a^{m+1}b; m \geq 0\}$  is a reduced Gröbner basis of  $\Pi_\varepsilon$ . So in this case, the R-completion of  $\Pi_\varepsilon$ , which is  $\Pi_\varepsilon$ , is properly included in the G-completion of  $\Pi_\varepsilon$ , and  $\Pi_\varepsilon$  is a type 1 counter-example.

Assume now  $w \neq \varepsilon$ . Composing  $bwb = abw$  with itself gives  $bwabw = abw^2b$ , which, composed with  $bwb = abw$ , gives  $bwa^2bw = abw^2b^2$ . Iterating this, *i. e.*, composing  $bwb = abw$  with the result of each previous composition, produces all relations  $bwa^m bw = abw^2b^m$  with  $m \geq 1$ .

We want to prove that the G-completion  $\mathcal{B}$  of the presentation (3.1) is infinite. We have seen that, for each  $m \geq 1$ , we have  $bwa^m bw \equiv abw^2b^m$ . It suffices to show that no relation of  $\mathcal{B}$  may reduce infinitely many different words  $bwa^m bw$ . For a contradiction, assume that (i)  $u = v$  is a relation of  $\mathcal{B}$  with  $\ell := |u|$  and (ii) there exists  $A \subsetneq \mathbb{N}$  infinite with  $\ell \leq \min A$  such that  $u = v$  reduces all words  $bwa^m bw$  for  $m \in A$ .

In the sequel, a word  $w$  is called *isolated* if it is  $\equiv$ -equivalent to no other word. For a word  $w$ , we shall denote by  $\#_b(w)$  the number of  $b$ 's in  $w$ .

If we have  $\ell \leq 1 + |w|$  then  $u$  is too short to include  $bwb$  or  $abw$ , and hence  $u$  is isolated, contradicting (i).

*Case 0:* the word  $u$  starts at position at least  $2 + |w|$  and finishes at position at most  $2 + |w|$  to the end, hence  $u$  has the form  $a^\ell$ . But  $a^\ell$  does not include neither  $bwb$  nor  $abw$  and is therefore isolated, which contradicts (i).

*Case 1:* there is a  $q$  such that  $u$  is a prefix of  $bwa^q$ . Because  $m > \ell$ , the word  $u$  has the form  $bwa^p$ ,  $p \geq 1$ . Then it contains no subword  $bwb$  because we have  $\#_b(bwb) > \#_b(bwa^p)$ . Similarly,  $u$  contains no subword  $abw$  because  $abw \subseteq bwa^p$  implies  $abw \subseteq wa^p$ , hence  $\#_b(bw) \leq \#_b(w)$ , and therefore  $u$  is isolated, which contradicts (i).

*Case 2:* the word  $u$  starts at position  $i$ , with  $i \geq 2$ ; hence there is a  $q$  such that  $u$  is a prefix of  $w'a^q$  for some suffix  $w'$  of  $w$ . We have  $\#_b(u) < \#_b(bwb)$  and  $\#_b(u) < \#_b(abw)$  and so neither  $bwb$  nor  $abw$  is a subword of  $u$ ; hence  $u$  is isolated, which contradicts (i).

*Case 3:* the word  $u$  finishes at position at most  $1 + |w|$  to the end. Then we have  $u = a^p bw'$  with  $p \geq 1$  and  $w'$  prefix of  $w$ ; since  $\ell > 1 + |w|$ , we exclude the case where  $u$  is a prefix of  $w$ . Because of the homogeneous lexicographic ordering, a matching word  $v$  has the form  $a^p v'$  and then, by cancellativity (see [5, Prop. 6.1]),  $bw$  reduces to  $v'$ , which is impossible because  $bw$  is of length  $1 + |w|$  and therefore too short not to be isolated. This contradicts (i).  $\square$

Observe in the previous proof that, although the reduced Gröbner basis is not computable, we are able to determine that it is necessarily infinite.

A typical instance of Proposition 3.2 is the standard presentation of the braid monoid  $B_3^+$ .

**Example 3.3.** The presentation  $(a, b; bab = aba)$  of the braid monoid  $B_3^+$ , with deglex order induced by  $b > a$ , satisfies the hypotheses of Proposition 3.2 and is therefore a type 1 counter-example. An easy computation [1, Lemma 4.1] gives the

reduced Gröbner basis

$$\{bab = aba\} \cup \{ba^n ba = aba^2 b^{n-1}; n \geq 2\},$$

which is in accordance with Proposition 3.2.

We shall now give other counter-examples. The presentation of the braid monoid  $B_3^+$  is the first non trivial case of 2-generator Artin presentation, and we can obtain more type 1 counter-examples by considering more general Artin presentations.

**Proposition 3.4.** *Every 2-generator Artin presentation*

$$(a, b; \underbrace{baba \dots}_{\text{length } m} = \underbrace{abab \dots}_{\text{length } m})$$

is a type 1 counter-example with respect to any homogeneous lexicographic order.

*Proof.* There are two cases. If the presentation has the type  $(a, b; (ba)^n b = (ab)^n a)$ , with  $n \geq 1$ , then by Proposition 3.2, the presentation is a type 1 counter-example.

We may assume that the presentation has the form  $(a, b; (ba)^n = (ab)^n)$ , with  $n \geq 1$ . Compose  $(ba)^n = (ab)^n$  with itself as follows:

$$((ba)^n - (ab)^n)ba - ba((ba)^n - (ab)^n) = -(ab)^n ba + ba(ab)^n.$$

Compose the resulting relation with  $(ba)^n = (ab)^n$  to get

$$(ba(ab)^n - (ab)^n ba)a - ba^2((ba)^n - (ab)^n) = -(ab)^n ba^2 + ba^2(ab)^n.$$

Iterating these compositions yields the family of relations

$$\{(ba)^n = (ab)^n\} \cup \{ba^p(ab)^n = (ab)^n ba^p; p \geq 1\}.$$

By Proposition 1.10, it suffices to check that every composition reduces to zero. We compute the composition of  $ba^p(ab)^n = (ab)^n ba^p$  with  $ba^q(ab)^n = (ab)^n ba^q$  and leave the other compositions to the reader:

$$\begin{aligned} & (ba^p(ab)^n - (ab)^n ba^p)a^q(ab)^n - ba^p(ab)^{n-1}a(ba^q(ab)^n - (ab)^n ba^q) \\ &= -(ab)^n ba^{p+q}(ab)^n + ba^p(ab)^{n-1}a(ab)^n ba^q \\ &\rightsquigarrow -(ab)^n (ab)^n ba^{p+q} + ba^p(ab)^{n-2}aba(ab)^n ba^q \\ &\rightsquigarrow -(ab)^{2n}ba^{p+q} + ba^{p+1}(ab)^n (ba)^{n-1}ba^q \\ &\rightsquigarrow -(ab)^{2n}ba^{p+q} + (ab)^n ba^{p+1}(ba)^{n-1}ba^q \\ &\rightsquigarrow -(ab)^{2n}ba^{p+q} + (ab)^n ba^p(ab)^n a^q \\ &\rightsquigarrow -(ab)^{2n}ba^{p+q} + (ab)^n (ab)^n ba^p a^q = 0. \end{aligned}$$

□

Another infinite family of type 1 counter-examples extending Example 3.3 in an other direction than Proposition 3.4 is the family of standard presentations of braid monoids:

**Proposition 3.5.** *For  $n \geq 3$ , the Artin presentation*

$$(3.2) \quad \left( \sigma_1, \dots, \sigma_{n-1} \mid \begin{array}{ll} \sigma_i \sigma_j \sigma_i = \sigma_j \sigma_i \sigma_j & \text{for } |j - i| = 1 \\ \sigma_i \sigma_j = \sigma_j \sigma_i & \text{for } |j - i| \geq 2 \end{array} \right)$$

of the braid monoid  $B_n^+$  is a type 1 counter-example.

*Proof.* It is a standard result, deduced from Proposition 2.10, that the monoids  $B_n^+$  are R-complete.

Take any  $i \leq n - 2$ ; put  $b = \max(\sigma_i, \sigma_{i+1})$  and  $a = \min(\sigma_i, \sigma_{i+1})$ . As in the case of  $B_3^+$ , the relation  $bab = aba$  of  $B_n^+$  leads Algorithm 1.11 to add all the relations  $ba^nba = aba^2b^{n-1}$ , with  $n \geq 2$ . It suffices to prove that these relations are not reduced by the relations of the reduced Gröbner basis  $\mathcal{B}$ . For a contradiction, suppose there is a relation  $u = v$  in  $\mathcal{B} - (\{bab = aba\} \cup \{ba^nba = aba^2b^{n-1}; n \geq 2\})$  reducing at least one relation  $ba^nba = aba^2b^{n-1}$ . So we have  $u \in \{a, b\}^*$ . Now,  $u \equiv v$  implies that there exist words  $u_0, u_1, \dots, u_n$  satisfying

$$u = u_0 \equiv^{(1)} u_1 \equiv^{(1)} \dots \equiv^{(1)} u_{n-1} \equiv^{(1)} u_n = v.$$

But there is a single relation in the presentation of  $B_n^+$  involving  $a$ 's and  $b$ 's, namely  $bab = aba$ . Therefore,  $u_0 \equiv^{(1)} u_1$  implies  $u_1 \in \{a, b\}^*$ , and it follows that  $v$  is in  $\{a, b\}^*$  and that the relation  $u = v$  holds in  $B_3^+$ ; hence the relations  $ba^nba = aba^2b^{n-1}$ , with  $n \geq 2$ , and  $bab = aba$  reduce  $u = v$  to zero, contradicting the fact that  $\mathcal{B}$  was reduced.  $\square$

**Example 3.6.** By Proposition 3.5, we know that the standard Artin presentation of the braid monoid  $B_4^+$

$$(a, b, c; bab = aba, ca = ac, cbc = bcb)$$

and order induced by  $c > b > a$  is a counter-example of type 1. Actually, a direct computation shows that its G-completion is:

$$\begin{aligned} bab &= aba, \\ cbc &= bcb, \\ ca &= ac, \\ ba^nba &= aba^2b^{n-1}, n \geq 2, \\ cb^n cb &= bcb^2c^{n-1}, n \geq 2, \\ cba^n c &= bcba^n, n \geq 1, \\ cba^n b^p cb &= bcba^n bc^p, n \geq 2, p \geq 1, \\ cb^{n_1} a^{n_2} b^{n_3} \dots b^{n_k} cba &= bcb^2 ac^{n_1-1} b^{n_2} c^{n_3} \dots c^{n_k}, \end{aligned}$$

with  $k \geq 2$ , and the  $n_i$ 's are positive integers satisfying  $n_2, n_3, \dots, n_{k-1} \geq 2$ , with the additional constraints:  $n_1 \geq 2$  if  $k = 2$  or  $k = 3$  holds, and  $n_k \geq 2$  if  $k$  is odd.

*Remark 3.7.* Bokut *et al.* [1, Th. 4.2] give Gröbner bases for every braid monoid  $B_n^+$ , with  $n \geq 3$ . The latter coincide with the ones computed in Examples 3.3 and 3.6. Although almost explicit, these bases are neither reduced nor minimal for the cases  $n \geq 5$  and therefore do not allow to conclude that the presentation of (3.2) is a type 1 counter-example, contrary to Proposition 3.5.

So far, we considered type 1 counter-examples. We conclude with what was called a type 1' counter-example, namely one where the R-completion is a proper subset of the G-completion and both are finite.

**Proposition 3.8.** *For every  $n \geq 1$  and  $p \geq 1$ , the presentation*

$$(3.3) \quad (a, b; (ab)^n a = b^p)$$

*together with the homogeneous lexicographic ordering induced by  $b > a$  is a type 1' counter-example.*

*Proof.* A 2-generator presentation  $(a, b; \mathcal{R})$  whose sole relation has the form  $a \dots = b \dots$  is R-complete [4, Prop. 6.4], and hence the presentation (3.3) is R-complete. Then, using Proposition 1.10, one checks that the set

$$\mathcal{B} = \{(ab)^n a = b^p, b^{p+1} a = ab^{p+1}\}$$

is the reduced Gröbner basis of the presentation (3.3).  $\square$

**3.2. Type 2 counter-examples.** In this section, we give examples of presentations whose G-completion is properly included in their R-completion.

**Lemma 3.9.** *Assume that  $(a, b; \mathcal{R})$  is a presentation with no relation  $a \dots = a \dots$  or  $b \dots = b \dots$ . Then, for each nonempty word  $w$  on  $\{a, b\}$ , the R-completion of  $(a, b; \mathcal{R}, bw = b)$  includes  $\{bw^n = b; n \in \mathbb{N}\}$ .*

*Proof.* The relation  $bw = b$  implies  $bw^n \equiv b$ , with  $n \geq 1$ . We prove by induction on  $n$ , that  $(bw^n)^{-1}b$  cannot be reversed to  $\varepsilon$  even if all the relations  $bw^m = b$ ,  $m < n$ , have been added to the presentation. Since  $(bw^2)^{-1}b$  reverses to  $w^{-1}$ , we can assume  $n > 2$ . By hypothesis, there is no relation  $s \dots = s \dots$  in  $\mathcal{R}$  and hence, the only reversings of  $(bw^n)^{-1}b$  are, for every  $p$  and  $m$  satisfying  $p < m < n$ ,  $(bw^n)^{-1}b \curvearrowright w^{-m}w^p \curvearrowright (w^{m-p})^{-1}$ ; this completes the induction.  $\square$

**Proposition 3.10.** *Under hypotheses of Lemma 3.9, every G-complete presentation  $(a, b; bw = b)$  is a counter-example of type 2.*

*Proof.* By Lemma 3.9, the R-completion of  $(a, b; bw = b)$  contains the set  $\{bw^n = b; n \in \mathbb{N}\}$  which, in turn, contains the G-completion, namely  $\{bw = b\}$ .  $\square$

**Example 3.11.** The simplest instance of Proposition 3.10 is the presentation  $(a, b; ba = b)$  whose Gröbner basis consists in the sole relation  $ba = b$  and whose R-completion is  $\{ba^n = b; n \in \mathbb{N}\}$ .

The next result is another application of Lemma 3.9 differing from Proposition 3.10 in that the set  $\mathcal{R}$  is nonempty.

**Proposition 3.12.** *For every  $n, q, p$  satisfying  $n + q > p$ , the presentation*

$$(a, b; a^n b^q = b^p, ba = b)$$

*with order induced by  $b > a$  is a counter-example of type 2.*

*Proof.* We first compute the G-completion. There is only one composition available:

$$\begin{aligned} (a^n b^q - b^p)a - a^n b^{q-1}(ba - b) &= -b^p a + a^n b^q \\ &\rightsquigarrow -b^p + a^n b^q \rightsquigarrow 0. \end{aligned}$$

Hence the presentation  $(a, b; a^n b^q = b^p, ba = b)$  is G-complete. Lemma 3.9 yields the result.  $\square$

**Remark 3.13.** It is natural, as in Section 3.1, to define a type 2' presentation to be a presentation  $(\mathcal{S}; \mathcal{R})$  satisfying  $\widehat{\mathcal{R}}^G \subsetneq \widehat{\mathcal{R}}^R$  and  $|\widehat{\mathcal{R}}^R| < \infty$ . However, contrary to the type 1', we could not find a presentation of type 2' so far. Most of the difficulty resides in the computation of R-completions. Indeed, during the completing process, the reversing operation often becomes, if it was not already, non-deterministic: if, at some point, we have two relations  $s \dots = s \dots$  at our disposal and  $s^{-1}s$  is to be reversed, then we can reverse in two different ways, leading to two different words.



**3.3. Type 3 counter-examples.** We conclude with examples where both completions are incomparable with respect to inclusion. First, we observe that mixing examples of what were called types 1 and 2 immediately leads to examples of type 3. But, then, we show that less artificial examples exist, namely the standard Heisenberg presentation.

We denote by  $X_1 \sqcup X_2$  the disjoint union of two sets  $X_1$  and  $X_2$  (that is,  $X_1 \sqcup X_2 = X_1 \times \{1\} \cup X_2 \times \{2\}$ ).

**Definition 3.14.** Let  $(\mathcal{S}_1, \mathcal{R}_1)$  and  $(\mathcal{S}_2, \mathcal{R}_2)$  be two presentations. The *direct product*  $(\mathcal{S}_1, \mathcal{R}_1) \times (\mathcal{S}_2, \mathcal{R}_2)$  is the presentation  $(\mathcal{S}_1 \sqcup \mathcal{S}_2, \mathcal{R}_1 \sqcup \mathcal{R}_2 \sqcup \mathcal{R})$  with  $\mathcal{R} = \{s_1 s_2 = s_2 s_1; s_1 \in \mathcal{S}_1, s_2 \in \mathcal{S}_2\}$ .

In the sequel, the orderings considered on the direct product of two ordered presentations will be the deglex order where the letters are ordered as follows: the orders on  $\mathcal{S}_1$  and  $\mathcal{S}_2$  are preserved and we put  $\max \mathcal{S}_1 < \min \mathcal{S}_2$ .

**Lemma 3.15.** *Let  $\mathcal{P}$  be the direct product of the semigroup presentations  $(\mathcal{S}_1, \mathcal{R}_1)$  and  $(\mathcal{S}_2, \mathcal{R}_2)$ . Then, using above notation, the reduced Gröbner basis of  $\mathcal{P}$  is  $\widehat{\mathcal{R}}_1^G \sqcup \widehat{\mathcal{R}}_2^G \sqcup \mathcal{R}$  and its R-completed set of relations is  $\widehat{\mathcal{R}}_1^R \sqcup \widehat{\mathcal{R}}_2^R \sqcup \mathcal{R}$ .*

*Proof.* To prove that  $\widehat{\mathcal{R}}_1^G \sqcup \widehat{\mathcal{R}}_2^G \sqcup \mathcal{R}$  is the reduced Gröbner basis of  $\mathcal{P}$ , by Proposition 1.10, it suffices to check that all compositions reduce to zero. There are no compositions left neither in  $\widehat{\mathcal{R}}_1^G$  nor in  $\widehat{\mathcal{R}}_2^G$  since both sets are reduced. It is obvious that  $\mathcal{R}$  contains no composition either. The only possible compositions not reducing to zero must therefore involve relations of two different sets among  $\widehat{\mathcal{R}}_1^G$ ,  $\widehat{\mathcal{R}}_2^G$  and  $\mathcal{R}$ . Since  $\mathcal{S}_1$  and  $\mathcal{S}_2$  have no intersection, there are no possible compositions between  $\widehat{\mathcal{R}}_1^G$  and  $\widehat{\mathcal{R}}_2^G$ . Because  $s_2 > s_1$  holds for each  $s_2$  in  $\mathcal{S}_2$  and  $s_1$  in  $\mathcal{S}_1$ , the first letter of the leading word of every relation of  $\mathcal{R}$  lies in  $\mathcal{S}_2$  and the last letter lies in  $\mathcal{S}_1$ . We leave the reader check that every composition of relations of  $\widehat{\mathcal{R}}_2^G$  and  $\mathcal{R}$  reduces to zero, the case involving  $\widehat{\mathcal{R}}_1^G$  being similar.

To prove that  $(\mathcal{S}_1 \sqcup \mathcal{S}_2; \widehat{\mathcal{R}}_1^R \sqcup \widehat{\mathcal{R}}_2^R \sqcup \mathcal{R})$  is R-complete, it suffices to check that every two equivalent words can be proven so by reversing. Now, if  $u$  and  $v$  are equivalent, then we have  $u \equiv u_1 u_2$  and  $v \equiv v_1 v_2$ , with  $u_1, v_1$  in  $\mathcal{S}_1^*$  and  $u_2, v_2$  in  $\mathcal{S}_2^*$ , satisfying  $u_1 \equiv v_1$  and  $u_2 \equiv v_2$ . These latter equivalences are provable by reversing (since we have all the relations of  $\widehat{\mathcal{R}}_1^R$  and  $\widehat{\mathcal{R}}_2^R$ ) and one can check that finding a reversing of  $u^{-1}v$  to  $\varepsilon$  amounts to finding reversings of  $u_1^{-1}v_1$  and  $u_2^{-1}v_2$  to  $\varepsilon$ .  $\square$

The next result gives a method to get type 3 counter-examples starting from counter-examples of type 1 and type 2.

**Proposition 3.16.** *Assume that  $(\mathcal{S}_1, \mathcal{R}_1)$  is a counter-example of type 1, and that  $(\mathcal{S}_2, \mathcal{R}_2)$  is a counter-example of type 2. Then  $(\mathcal{S}_1, \mathcal{R}_1) \times (\mathcal{S}_2, \mathcal{R}_2)$  is a counter-example of type 3.*

*Proof.* By hypothesis, the sets  $\widehat{\mathcal{R}}_1^R \sqcup \widehat{\mathcal{R}}_2^R$  and  $\widehat{\mathcal{R}}_1^G \sqcup \widehat{\mathcal{R}}_2^G$  are not comparable. Thus, by Lemma 3.15, the Gröbner- and R-completions of  $(\mathcal{S}_1, \mathcal{R}_1) \times (\mathcal{S}_2, \mathcal{R}_2)$  are not comparable.  $\square$

The latter proposition gave a way to build type 3 counter-examples as direct products of type 1 and type 2 counter-examples. There are however less trivial presentations of type 3 not arising as direct products.

**Proposition 3.17.** *When equipped with the order  $c > b > a$ , the presentation*

$$(a, b, c; ab = bac, ac = ca, bc = cb)$$

*of the Heisenberg semigroup is a counter-example of type type 3.*

*Proof.* Following [5, Ex. 5.4], the R-completed presentation is  $(a, b, c; ab = bac, ac = ca, bc = cb, cba = ab)$ . Using Algorithm 1.11, we find for the G-completion the set

$$\begin{aligned} \{cb = bc, ca = ac\} \cup \{ba^{n+1}c = aba^n; n \geq 0\} \\ \cup \{ba^{2n}b = a^n b^2 a^n; n \geq 1\} \cup \{ba^{2n+1}b = a^n baba^n; n \geq 1\}. \end{aligned}$$

We first notice that the G-completion is infinite and therefore Heisenberg presentation is neither of type 1', nor type 2, nor type 2'. We see that the relation  $ab = bac$  of the R-completion is not in the G-completion and thus Heisenberg presentation is not a type 1 counter-example.  $\square$

#### 4. CANCELLATIVITY

In this section, we compare R-complete and G-complete presentations in terms of cancellativity of the associated monoids. Here also, the two notions of complete presentations lead to divergent results: in the case of an R-complete presentation, left cancellativity can be read from the presentation directly, while no such result exists for a G-complete presentation.

**4.1. Reading cancellativity off a complete presentation.** One of the nice features of an R-complete presentation is that one can very easily establish the possible left cancellativity property for the associated monoid by only inspecting the relations.

**Proposition 4.1** ([5, Prop. 6.1]). *Assume that  $(\mathcal{S}; \mathcal{R})$  is an R-complete presentation. Then the monoid  $\langle \mathcal{S}; \mathcal{R} \rangle^+$  admits left cancellation if and only if  $u^{-1}v \curvearrowright \varepsilon$  holds for every relation of the form  $su = sv$  in  $\mathcal{R}$  with  $s \in \mathcal{S}$ .*

In particular, we get that proving that a monoid is not left cancellative amounts to finding a relation  $su = sv$  in  $\mathcal{R}$  for which  $u^{-1}v \curvearrowright \varepsilon$  does not hold, *i. e.*, the presentation being R-complete, a relation  $su = sv$  for which  $u \equiv v$  does not hold. This means that if there is an obstruction to cancellativity, then it appears in the relations of the presentation, as soon as it is R-complete.

When we consider G-complete presentations instead, the criterion of Proposition 4.1 remains necessary, but it is no longer sufficient.

**Proposition 4.2.** (i) *Assume  $(\mathcal{S}; \mathcal{R})$  is a reduced G-complete presentation. If  $\mathcal{R}$  contains a relation of the type  $su = sv$  with  $u, v$  nonempty words of  $\mathcal{S}^*$ , then the monoid  $\langle \mathcal{S}; \mathcal{R} \rangle^+$  is not left cancellative.*

(ii) *There exists a G-complete presentation  $(\mathcal{S}; \mathcal{R})$  such that  $\mathcal{R}$  contains no relation of the type  $su = sv$  with  $u, v$  nonempty words of  $\mathcal{S}^*$ , and nevertheless the monoid  $\langle \mathcal{S}; \mathcal{R} \rangle^+$  does not admit left cancellation.*

*Proof.* (i) Suppose the monoid  $\langle \mathcal{S}; \mathcal{R} \rangle^+$  is left cancellative. Thus we have  $u \equiv v$  and  $u = v$  is not a relation of  $\mathcal{R}$ , otherwise the presentation  $(\mathcal{S}; \mathcal{R})$  would not be reduced. We prove that this is not possible.

Since we fixed an order compatible with the concatenation in the monoid, the inequality  $su > sv$  implies  $u > v$ . This latter inequality combined with the equivalence  $u \equiv v$  means that  $u$  or  $v$  can be reduced to its normal form. Hence suppose

there is a relation  $w = w'$  in  $\mathcal{R}$  with  $w$  a subword of  $u$ . This means that the relation  $su = sv$  was not reduced, which contradicts the hypothesis. The same applies to  $v$ . Thus there is no relation  $w = w'$  with  $w$  a subword of  $u$  or  $v$ . Therefore  $u$  and  $v$  must be reduced, which contradicts  $u > v$ .

(ii) Take the monoid presented by  $(a, b, c; ca = ba, cb = ba)$ . With the homogeneous lexicographic order induced by  $c > b > a$ , this presentation is G-complete. From  $ca = ba$  and  $cb = ba$  we get  $ca \equiv cb$ . Now,  $a \equiv b$  does not hold and hence the monoid is not left cancellative.  $\square$

Proposition 4.2 establishes that for a presentation to give rise to a cancellative monoid, there has to be no relation  $s\dots = s\dots$  and conversely, that even without relation of the type  $s\dots = s\dots$ , there exist G-complete presentations associated to non cancellative monoids. In the proof, the relations of the presentation  $(a, b, c; ca = ba, cb = ba)$  suggest that cancellativity might be linked to the particular presentations possessing two relations  $su = w$  and  $sv = w$  with  $u \neq v$  and  $w$  not starting with an  $s$ . This is not the case:

**Proposition 4.3.** *There exist a G-complete presentation  $(\mathcal{S}; \mathcal{R})$  such that the monoid  $\langle \mathcal{S}; \mathcal{R} \rangle^+$  is not left cancellative yet  $\mathcal{R}$  contains no pair of relations  $su = w$ ,  $sv = w$  with  $u \neq v$  and  $w$  not starting with  $s$ .*

*Proof.* Consider the presentation

$$(\mathcal{S}; \mathcal{R}) = (a, b, c, r, s, t; sba = tca, cab = bb, tbb = rcb, sa = rc)$$

and the homogeneous lexicographic order induced by  $a < b < c < r < t < s$ . By Prop. 1.10 this presentation is G-complete. In the monoid  $\langle \mathcal{S}; \mathcal{R} \rangle^+$ , we have  $sab \equiv rcb$  and  $sbab \equiv rcb$  and hence  $sbab \equiv sab$ . If the monoid is left cancellative, then we must have  $bab \equiv ab$ . Now  $bab$  and  $ab$  are both reduced and therefore not equivalent.  $\square$

**4.2. Infinite completions.** We have considered in Section 3.1 many infinite G-completions of presentations associated to cancellative monoids. Contrastingly, all above-mentioned examples involving an infinite R-completion turn out to be associated with monoids that are not left cancellative, and one could wonder whether this situation necessarily occurs. Actually, it is not the case:

**Proposition 4.4.** *There exists a finite presentation admitting an infinite R-completion yet the associated monoid is left and right cancellative.*

*Proof.* Consider the presentation

$$(4.1) \quad (a, b, c, d; ab = bac, bc = cbd, da = ad, bd = db, dc = cd).$$

Denote by  $\#_{a < b}(u)$  (resp.  $\#_{b < a}(u)$ ) the number of pairs  $(i, j)$  with  $i < j$  such that the  $i$ th letter of  $u$  is an  $a$  (resp.  $b$ ) and the  $j$ th letter is a  $b$  (resp.  $a$ ). We define  $\lambda$  on the set of words as follows:

$$\lambda(u) = |u| + 2\#_{a < b}(u) + \#_{b < a}(u).$$

One checks on the relations of (4.1) that  $\lambda$  is a pseudolength. Applying Algorithm 2.9, we find that the R-completion for the presentation of (4.1) is the set

$$\{ab = bac, bc = cbd, da = ad, bd = db, dc = cd\} \cup \{b(ac)^n c = da^n cb; n \geq 0\}.$$

Finally, Proposition 4.1 and the fact that there is no relation  $s\dots = s\dots$  in (4.1) imply that the associated monoid is left cancellative.

As for right cancellativity, we appeal to left reversing [5], a notion symmetric to that of (right) reversing. As the (right) R-completeness involved in Proposition 4.1 leads to left cancellativity, left R-completeness leads to right cancellativity. So it suffices to prove that the presentation (4.1) is left R-complete; this is similar to proving its right R-completeness and hence we omit it.  $\square$

## REFERENCES

- [1] L.A. Bokut, Y. Fong, W.-F. Ke, and L.-S. Shiao. Gröbner-Shirshov bases for the braid semi-group. In *Advances in algebra*, pages 60–72. World Sci. Publ., 2003.
- [2] L.A. Bokut, Y. Fong, and L.S. Shiao. Gröbner-Shirshov bases for algebras, groups, and semi-groups. In *Proceedings of the Third International Algebra Conference (Tainan, 2002)*, pages 17–32. Kluwer Acad. Publ., 2003.
- [3] P. Dehornoy. Deux propriétés des groupes de tresses. *C.R. Acad. Sci. Paris*, 315:633–638, 1992.
- [4] P. Dehornoy. Groupes de Garside. *Ann. Sci. École Norm. Sup. Paris*, 35:267–306, 2002.
- [5] P. Dehornoy. Complete positive group presentations. *J. Algebra*, 268:156–197, 2003.
- [6] P. Dehornoy and L. Paris. Gaussian groups and Garside groups, two generalizations of Artin groups. *Proc. London Math. Soc.*, 79(3):569–604, 1999.
- [7] C.F. Miller III. *On Group Theoretic Decision and Their Classification*. Ann. of Math. Stud. Princeton Univ. Press, 1971.
- [8] F. Mora. Gröbner bases for non-commutative polynomial rings. In Springer, editor, *Proc. AAEC 3*, volume 229 of *Lect. Notes Comput. Sci.*, pages 353–362, 1986. Zbl 0659.16003.
- [9] V.A. Ufnarovskij. *Combinatorial and Asymptotic Methods in Algebra*, volume 57 of *Encyclopaedia of Mathematical Sciences*, chapter I, pages 1–196. Springer, 1995. Zbl 0826.16001.

*E-mail address:* autord@math.unicaen.fr