

# Construction of a secure cryptosystem based on spatiotemporal chaos and its application in public channel cryptography

Xingang Wang,<sup>1</sup> Meng Zhan,<sup>1</sup> Xiaofeng Gong,<sup>1</sup> and Choy Heng Lai<sup>2</sup>

<sup>1</sup>*Temasek Laboratories, National University of Singapore, 117508, Singapore*

<sup>2</sup>*Department of Physics, National University of Singapore, 117542, Singapore*

By combining the one-way coupled chaotic map lattice system with a bit-reverse operation, we construct a new cryptosystem which is extremely sensitive to the system parameters even for low-dimensional systems. The security of this new algorithm is investigated and mechanism of the sensitivity is analyzed. We further apply this cryptosystem to the public channel cryptography, based on "Merkle's puzzles", by employing it both as pseudo-random-number (PN) generators and symmetric encryptor. With the properties of spatiotemporal chaos, the new scheme is rich with new features and shows some advantages in comparison with the conventional ones.

PACS numbers: 05.45.Vx

One serious problem in chaos synchronization based encryptions is that parameters close to the secret key can still synchronize systems to a certain extent, and usually appears a regular structure in the key space under the known-plaintext attack. In other words, there is always a key basin of finite width around the secret key. The keys in this basin are highly correlated, and the system security is broken once the location of the key basin is located and explored. Although in some methods, like those exploiting spatiotemporal chaos or the modulo operation, can complicate the cryptanalysis, system security is still vulnerable because the basin width increases monotonically with the amount of known plaintext. In this paper, we incorporate a conventional bit operation, the bit-reverse operation, into spatiotemporal chaos, and find that the basin width shrinks to zero in terms of the computational precision. This approach not only extends the definition of the secret key to the real domain and enlarges the capacity of the key space accordingly, but also overcomes the problem of correlations in key basin entirely. Using the proposed cryptosystem both as a set of pseudo-random-number (PN) generators and a symmetric encryptor, we further investigate the feasibility of public channel cryptography based on chaos, and propose a prototype for application. In comparison with the conventional methods, the new model is superior in many aspects: flexibility, manageability, and simplicity. These new features, together with the experimental progress in chaos-based communication, make this scheme a good candidate for public channel cryptography both in software and hardware.

## I. INTRODUCTION

As an important application of chaos, chaos-based secure communication and cryptography attracted continuous interest over the last decade [1, 2, 3, 4, 5, 6, 7, 8, 9, 10, 11, 12]. For convenience and flexibility, most of the proposed schemes are based on the phenomenon of chaos synchronization, where two chaotic systems can be synchronized through driving or coupling [1, 13]. While synchronization brings certain advantages for practical applications, it also presents some drawbacks on the system security [14, 15, 16]. Later it is found that even for high dimensional chaotic systems, which usually possess higher complexity and multiple positive Lyapunov exponents, the system security is still vulnerable under some sophisticated attacks [11]. Besides the problem of security, in comparison to those conventional schemes used widely in engineering, the performance of chaos encryptions are also disappointing in other aspects such as having low encryption speed and high bit error rate, etc [17, 18, 19]. How to design a secure while efficient cryptosystem has always been a challenge for the chaos cryptographer.

More recently, the study of applying one-way coupled map lattices (OCML) for encryption sheds some new light on this research [8]. One significant point of this scheme is that two classical numerical operations, namely integration and modulation, are incorporated into the chaotic dynamics. With these operations, system security, as well as other performance indicators, can be greatly improved to a comparable level with those of the conventional ones, such as DES and AES [9]. In a most recent study [10], system security is further improved by adding a S-box, another technique typically used in conventional encryptions, to the coupled lattices. As a result the capacity of the key space is further enlarged and the system becomes even more sensitive on the parameters. However, these schemes still suffer from the problem of the "continuity" of chaotic dynamics, i.e., correlations still exist between the keys [11].

In conventional cryptography, encryption schemes are

divided into symmetric and asymmetric methods [20]. In contrast to the symmetric methods, the keys in the asymmetric methods are generated in pairs, a public key and a private key, and it is computationally not feasible to deduce the private key from the public key. Anyone with the public key can encrypt a message but not decrypt it. Only the person with the private key can decrypt the message. Mathematically, the process is based on the trap-door one-way functions, and encryption is the easy direction and decryption is the difficult direction. Communication strategies that use asymmetric methods for encryption have much greater inherent security than symmetric methods, since they eliminate the problem of key distribution, which itself can pose the most serious security risk. However, most of the proposed chaos-based encryption schemes are within the branch of symmetric methods, and little attention has been paid to asymmetric encryptions, or public-key cryptography (PKC) [21]. Whereas all known PKC algorithms are based on some hard problems in number theory (factoriation, knapsack, discrete logarithms, etc.), it is of great interest and challenge to construct PKC algorithms based on dynamics.

In the present work, we propose a new scheme of chaos-based symmetric encryption and, using the proposed cryptosystem both as symmetric encryptor and pseudo-random-number (PN) generators, design a prototype for public channel cryptography. In the new cryptosystem, the outputs are extremely sensitive to the secret key. Any detectable mismatch of the secret key, of the order of the computer precision, will induce a totally different set of outputs. Hence this scheme not only overcomes the basic problem of "continuity" met in chaos-based encryptions, but also extends the definition of the secret key to all real values in the key space. Borrowing the concept of "Merkle's Puzzles" [22], we further construct a new model for public channel cryptography where all blocks are endowed with spatiotemporal chaos. In comparison with conventional methods, the new model is found to be more efficient and flexible in some aspects.

This paper is arranged as follows. In Section II we describe our new method for constructing chaos-based cryptosystems and, in Section III, we give a detailed discussion of its sensitivity and security. The prototype for PKC is presented in Section IV, and the system security is analyzed in Section V. We highlight the new features and advantages of the PKC in Section VI.

## II. CONSTRUCTING CRYPTOSYSTEM OF HIGH SECURITY

As cryptosystems based on low dimensional chaos have been shown [14] to be vulnerable, there have been several efforts to improve the security by employing spatiotemporal chaos [7]. Although these cryptosystems perform well against some conventional attacks (like the differential and linear attacks), and can even resist some classical chaos-based attacks (like the return map and re-

construction attacks [14]), they still suffer some inherent drawbacks from chaos dynamics [11, 17]. For example, when chaos synchronization is used for encryption, the keys close to the secret key can still synchronize the receiver system to a certain extent, thus forming a key basin around the secret key. (For more details about the definition of key basin, please refer Ref. [8, 11].) Since the system security is directly connected with the structure of this basin, it be broken down once the location of this basin is explored. Based on this, an effective known-plaintext attack [20], the error function attack (EFA), has been proposed specifically for cracking chaos synchronization based cryptosystems [11]. It is found that, under EFA, most of the proposed cryptosystems are vulnerable or not secure at all, and for some situations the higher dimensionality does not help to improve system security.

The underlying reason for this "continuity" is that the Lyapunov exponent (LE) in conventional chaotic systems is not large enough to quickly diffuse the nearby states in phase space. It is thus natural to look to the exploration and construction of chaotic systems with large LE for chaos cryptography, at least as far as EFA attack is concerned. Along this direction, two methods have been proposed [9]: (1) using several of the last significant digits as the output signals and, (2) coupling lattices with a weak signal. Through these methods, system sensitivity can be significantly improved, and the width of the key basin shrinks accordingly. However, as pointed out in Ref. [10], there still exists a scaling between the amount of known plaintext and the width of the key basin: the more plaintext is known, the wider the key basin will be. In this respect, the problem of the key basin remains fundamentally unsolved.

We extend the study in Ref. [10] and aim to design cryptosystems that are "truly" secure. By this we mean cryptosystems with the property that the sizes of the key basins are of the order of the computational precision (or the measure precision in practice), and which remain unchanged with the amount of plaintext known to the attacker. Instead of the S-box, we construct the transmitter by incorporating a bit-reverse operation,  $F$ , into the one-way lattice ring of  $N$  coupled logistic maps, and the dynamics of the transmitter can be formulated as

$$\begin{aligned} x_0(n) &= S_N(n)/2^\nu, \\ x_1(n+1) &= (1 - \varepsilon_1)f[x_1(n)] + \varepsilon_1f[x_0(n)], \\ x_2(n+1) &= (1 - \varepsilon_2)f[x_2(n)] + \varepsilon_2f\{F[x_1(n)]/2^\nu\}, \\ x_i(n+1) &= (1 - \varepsilon_i)f[x_i(n)] + \varepsilon_if[x_{i-1}(n)], \\ f &= 4x(1-x), \quad i = 3, 4, \dots, N, \end{aligned} \quad (1)$$

with

$$\begin{aligned} S_N(n) &= \{\text{int}[x_N(n) \times 10^h]\} \bmod 2^\nu, \\ F(x) &= \text{Reverse}\{\text{int}[x \times 10^h] \bmod 2^\nu\}. \end{aligned} \quad (2)$$

Reverse{ } represents a bit-reverse operation which reverses the bit string of an integer and generate another integer as the output.  $2^v$  is a large integer and  $10^{-h}$  is the computer precision.

The dynamics of the receiver (denoted by variables  $y_i(n)$ ,  $i = 1, 2, \dots, N$ ) is identical to that of the transmitter except that the first lattice,  $y_1(n)$ , is driven by  $x_0(n)$ . It can be proved that the two systems can be synchronized under the same driver signal,  $x_0(n)$ , given  $\varepsilon_i > 0.75$ ,  $i = 1, 2, \dots, N$ . In our model, we fix  $\varepsilon_i = 0.95$ ,  $i = 2, \dots, N$ , and adopt  $\varepsilon_1$  as the secret key and define the key space as  $\varepsilon_1 \in [0.95, 1)$ .

For encryption, at the transmitter side, each lattice except the first one can be regarded as an encryptor. To encrypt a message  $P_i(n)$  in the  $i$ th channel, we simply perform an XOR (exclusive OR) operation on this message with the last significant  $v$  bits of the information of  $x_i(n)$ , and the output ciphertext reads

$$\begin{aligned} C_i(n) &= \text{XOR} [P_i(n), X_i(n)], \\ X_i(n) &= \{\text{int}[x_i(n) \times 10^h]\} \bmod 2^v, \quad i = 2, \dots, N \end{aligned} \quad (3)$$

The ciphertexts,  $C_i(n)$ , and driver signal  $x_0(n)$  are then transmitted to the receiver. The receiver recovers the transmitted message through the function

$$P'_i(n) = \text{XOR} [C_i(n), Y_i(n)], \quad i = 2, \dots, N \quad (4)$$

with  $Y_i(n)$  having the same definition as  $X_i(n)$  but at the receiver end. With the same secret key,  $\varepsilon_1$ , the two systems,  $x$  and  $y$ , can be completely synchronized, and we finally have  $P'_i(n) = P_i(n)$ .

### III. SECURITY ANALYSIS

The key point of this cryptosystem is the bit-reverse operation adopted in Eqs. 1. Since the only secret of symmetric encryption is the key, the central task of such a cryptosystem is to make the outputs,  $X_i$ , as sensitive to the secret key as possible. In this scheme, any detectable mismatch of  $\varepsilon_1$  (of the order of computer precision) will affect at least the value of the last bit in  $X_1$ . Due to the bit-reverse function, this last significant bit becomes the most significant one when coupled to  $x_2$ , and thus induces a large difference in  $X_2$  and other outputs as well. This is further reflected in the behavior of the LE: the bit-reverse operation is equal to increasing the largest LE (LLE) with a value of about  $h \ln 10$ . Thus, the LLE in the newly constructed cryptosystem is estimated to be

$$\lambda' \approx \lambda + h \ln 10, \quad (5)$$

with  $\lambda$  being the original LLE of OCML. For computations with double arithmetic precision,  $h = 16$ , and with the last  $v = 30$  bits of information adopted as the outputs, the value of the LLE for  $N = 5$  coupled lattices is about  $\lambda' \approx 45$ , a value which can diffuse any detectable mismatch of the secret key,  $\varepsilon_1$ , to the order of its key

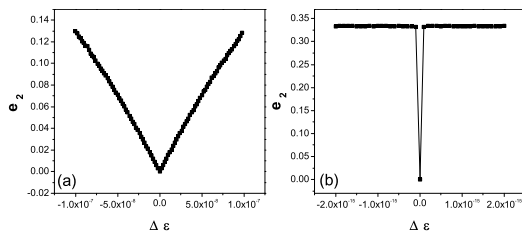

FIG. 1: For OCMLs of size  $N = 5$  and  $T = 2 \times 10^6$  known plaintexts, the EFA results of the second channel for encryption schemes: (a) proposed in Ref. [8], and (b) proposed in Section II. The width of the key basin in (b) is the same as the computer precision,  $10^{-16}$ , and does not change as  $T$  increases.

space within a few iterations, and thus totally confuses the "continuity" property in chaos dynamics.

For an eavesdropper, it is easier to attack the 2nd channel than the others (studies show that the security of the encryption channel increases exponentially with the size of the OCML [9]). We will thus focus on evaluating the security of this channel in the following. Assuming that the eavesdropper knows the whole dynamics of Eqs. 1 and can find an large amount of plaintext-ciphertext pairs, all he/she needs is to explore the secret key,  $\varepsilon_1$ , or the key basin where it is located (we consider here the most common attack used in cryptanalysis: the known-plaintext attack). By trying some test keys,  $\varepsilon'_1$ , the eavesdropper can study the structure of the key basin by the EFA function [11],

$$e_2(\varepsilon'_1) = \frac{1}{T} \sum_{n=1}^T \left| P'_{2,\varepsilon'_1}(n) - P_{2,\varepsilon_1}(n) \right|, \quad (6)$$

with  $T$  the amount of known plaintext and  $P'_{2,\varepsilon'_1}$  is the test plaintext generated under the test key  $\varepsilon'_1$ . Usually there will exist a key basin of a certain width around the secret key, and the system security will be compromised once this basin is explored.

In Fig. 1(a), we plot the EFA result of the model used in Ref. [8] with respect to the mismatch between the test key and the secret key,  $\Delta \varepsilon = \varepsilon'_1 - \varepsilon_1$ . It can be found, around the secret key, that there exists a smooth basin at least with a width of  $10^{-7}$ . With this basin structure, once the location of the key basin be explored, one can easily get close to the secret key, which is located at the bottom of the key basin, using only several test keys by some optimized searching methods. As a comparison, we also plot in Fig. 1(b) the EFA result of Eqs. 1. It is found that the width of the key basin is just the same as the computer precision  $10^{-16}$ . The interesting feature is that, in Fig. 1(b), the width of the key basin does not increase with  $T$ . We plot Figs. 1(a) and (b) using  $T = 2 \times 10^6$  known plaintexts, and had also tested different values of  $T$  up to  $10^9$ . The results confirmed that there is no change for these structures, and that the basin in Fig. 1(b) still has the width of the order of the computer precision. This property can be immensely useful

in preventing attempts to undermine the system security by studying the key basin structure (according to the study of Ref. [10], even in systems where the modulo operation is adopted, the relation between the key basin width,  $W$ , and the amount of known plaintext,  $T$ , follows the scaling  $W \propto T^{0.3}$ ).

Two points make this new cryptosystem distinctive and advantage to other schemes. Firstly, the capacity of the key space can be further extended. Every real value in the key space can be regarded as an independent secret key, and the number of independent keys in the key space is limited only by the computer precision. Secondly, the inherent property of "continuity" in chaotic systems is now avoided entirely at the level of computational precision. This renders it hopeless for those attacks based on analyzing the structure of the key basin. For other encryption performance indicators (such as the properties of diffusion and confusion, correlations, robustness, etc.), our numerical simulations [23] confirmed that there is no difference between this new cryptosystem and the former schemes (Ref. [8, 9]).

#### IV. APPLYING CHAOS-BASED CRYPTOSYSTEM FOR PUBLIC CHANNEL CRYPTOGRAPHY

Besides encryption, due to its excellence performance on statistical properties, the proposed cryptosystem also can be used as a set of pseudo-random-number (PN) generators. For this purpose, each lattice can be regarded as an independent PN generator, and all these generators produce PN sequences simultaneously. We have checked the random properties of these sequences with different types of evaluations (such as the run distribution, balance, power spectrum density, etc.) for arbitrary plaintexts, and they passed all these checkings satisfactorily [23]. In addition, in comparison with the conventional PN sequences, these new sequences possess extremely long periods which increase exponentially both with the system size and the computer precision. Another interesting observation is that although there is no statistical correlation between these sequences, the lattices are still under the dynamical relation of generalized synchronization (GS) [24]. This special property can be of great use in certain situations where a large number of independent PN generators are required to operate simultaneously, and yet are to be kept in step in some sense. The GS relation between lattices also makes it possible to manipulate all these generators with only a few controllers. Rather than adjusting all parameters in the generators, now we are able to generate a totally different set of PN sequences through resetting only one or a few parameters.

In the field of conventional cryptography, there is one type of PKC, namely the "Merkle's Puzzles", whose security depends on the protocol rather than number theory. Different to the other PKC schemes, where both the pub-

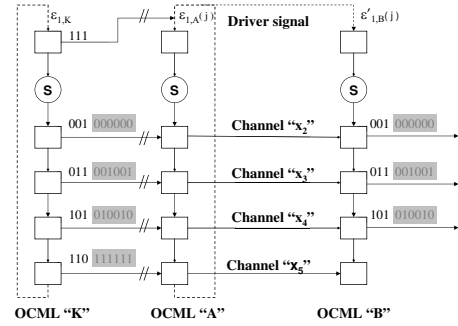

FIG. 2: Prototype for public channel cryptography constructed by three OCMLs. The dash lines represent feedback or driving signals, shadowed numbers represent the identifying codes, and " //" means OCML "K" is triggered each time  $T'$ .

lic key and private key are predefined, in "Merkle's Puzzles", both keys are decided by the receiver at random, and the keys will be destroyed after each transmission. A set of independent PN generators and one efficient symmetric encryptor are the basic blocks for this PKC. In conventional methods, usually it is difficult to manage (mainly store and compare) such a large number of PNs; it is also not easy to find a symmetric encryptor whose security can be adjusted flexibly so as to keep pace with the improving computer speed. In this section, we will apply the above proposed cryptosystem on "Merkle's Puzzles".

The prototype of the PKC is plotted in Fig. 2. The transmitter is composed of two OCMLs, OCML "K" ("K") used as PN generators and OCML "A" ("A") used as symmetric encryptor. The receiver comprises the decryptor OCML "B" ("B"). All OCMLs follow Eqs. 1. Without "K", the dynamics of the transmitter is identical to that of the receiver, and it is just the cryptosystem for symmetric encryption proposed in Section II. "S" represents the bit-reverse operation in Eqs. 2. "K" has two functions: (1) generating plaintext for "A" and, (2) modulating the coupling strength of the first lattice (which is used as the session key for the symmetric encryptions between "A" and "B"),  $\varepsilon_{1,A}$ , in "A". "K" is triggered for each time interval  $T'$ , a session during which both the plaintext and  $\varepsilon_{1,A}$  remain constant. Following that, in the next  $T'$  iterations, "A" encrypts the plaintext outputted from "K" repeatedly under the session key  $\varepsilon_{1,A}(j)$ , with  $j$  the iteration time of "K".

For the transmitter, the only secret is the parameter  $\varepsilon_{1,K}$ . Both the dynamics, "K" and "A", and the initial conditions of "K" are public. The transmitter has two missions: producing a large number of encryption sessions and deducing the private key chosen by the receiver. For the receiver, the dynamics is public and, before deciding on the public keys, the authorized receiver has no privilege over the eavesdropper. The task of the receiver is to decrypt one of the transmitted sessions at random,

and returns the decrypted plaintexts - the public keys - to the transmitter through the public channel.

The details about how to transmit a private key through the public channel can be described as follows (for OCMLs of size  $N = 5$ ):

1. "K" generates 5 integers,  $X_{i,K}(j)$ ,  $i = 1, \dots, 5$ , by Eqs. 3, and marks each of the later four integers with an identification code  $I_{i,K}$ . For instance, in Fig. 2, let us assume the binary format of the generated integer by  $x_{2,K}$  is  $X_{2,K}(j) = '001'$ , and mark it with an identification code  $I_{2,K} = '000000'$ . (For simplicity, the word lengths of the integer and the identification code here are just used to illustrate the operations, and in actual simulations both are with the word length of  $v = 30$ .) The identification code is only used for marking the channels and is also public. There is no identification code for  $X_{1,K}(j)$ , which will be used to modulate the parameter  $\varepsilon_{1,A}$  in "A". After this, "K" will be dormant until triggered again for the next session after time  $T'$ .
2. Treating all the marked integers as plaintext, each channel of "A", according to Eqs. 3, encrypts the same plaintext repeatedly for  $T'$  times under the same session key,  $\varepsilon_{1,A}(j)$ , which is modulated by the integer  $X_{1,K}(j)$  through function

$$\varepsilon_{1,A}(j) = 0.95 + \frac{1}{20}X_{1,K}(j)/2^v. \quad (7)$$

3. The transmitter repeats steps (1) and (2) until a large number,  $L$ , of sessions are generated and transmitted to the receiver.
4. "B" chooses one session at random and performs a brute-force attack to recover the session key  $\varepsilon_{1,A}(j)$  by checking the decrypted channel identification codes (which are predefined and public) through synchronization. ( $T'$  is set so as to ensure that "A" and "B" can be synchronized for any random initial conditions. In this prototype,  $T' = 100$  is large enough for this purpose.) This is a large, but still manageable, amount of work.
5. After being able to crack one of the sessions successfully, "B" keeps the last recovered plaintext  $X_{5,K}(j)$  as the private key and returns all other recovered plaintexts,  $X_{i,K}(j)$ ,  $i = 2, 3, 4$ , to the transmitter together with their identification codes. The return messages are transferred to "K" in the form of plaintext and are public to everyone. These plaintexts make up the set of public keys.
6. After receiving the public keys, the transmitter runs "K" with the predefined initial conditions (which is also public) and his secret key  $\varepsilon_{1,K}$  (known only to the transmitter). Once the outputs of the lattices match up the returned public keys

in each corresponding channel simultaneously, the transmitter will know that the output of the last lattice,  $X_{5,K}(j)$ , is the private key which the receiver had chosen, and which will be used for later communications.

## V. SECURITY OF PUBLIC CHANNEL CRYPTOGRAPHY

The security of this PKC depends on the number of sessions transmitted. The eavesdropper can break this system, but he has to do far more work than either the transmitter or the receiver. To recover the private key  $X_{5,K}(j)$  in steps (4) and (5), on average, he has to perform a brute-force attack against about half of the transmitted sessions generated in step (3). Assuming that in total there are  $L$  sessions transmitted in the public channel, the attack of the eavesdropper has a complexity of  $L/2$  times that of the receiver. The public keys,  $X_{i,K}(j)$ ,  $i = 2, 3, 4$ , will not help the eavesdropper either; they are independent PNs generated by the cryptosystem Eqs. 1. In general, the eavesdropper has to expend approximately the square of the effort that the receiver expends. This advantage is small by cryptographic standards, but in some circumstances it may be enough. For instance, in simulations (on a Pentium computer of 2GHZ CPU and 521M RAM, Fortran90 compiler), we set the duration for each session as  $T' = 100$  and the key space of the range  $\varepsilon_{1,A} \in [0.95, 0.95 + 1 \times 10^{-8}]$ , the transmitter can generate about  $L \approx 1 \times 10^8$  sessions in one minute, and the receiver needs another minute to explore one session key  $\varepsilon_{1,A}(j)$ . However, with the same computing facilities, it will take the eavesdropper about two years to break the system, a time that is likely to be longer than the useful lifetime of the secret message.

The eavesdropper can of course attack only the private key  $X_{5,K}$  used in the later communications, without considering the problem of PKC. But with the system under consideration, the private key can be combined randomly and adjusted freely both in length and position. While this add no additional cost to PKC, it will be a disaster for an eavesdropper and he/she finally has to fall back on attacking the sessions. Meanwhile, the excellent performance on correlations of the system prevents any attempt to deduce the private key  $X_{5,K}(j)$  from the public keys  $X_{i,K}(j)$ ,  $i = 2, 3, 4$ . The knowledge of the initial conditions cannot help with predicting  $\varepsilon_{1,K}(j)$  or  $X_{5,K}(j)$  either. With the bit-reverse operation, the difference between two corresponding outputs,  $\Delta X_{i,K}(j) = |X_{i,K}(j) - X_{i,K'}(j)|$ , increases to the order of attractor size within a few iterations, and after that the behavior of the two systems are totally different. (For example, with  $N = 5$  and  $\Delta\varepsilon = \varepsilon_{1,K} - \varepsilon_{1,K'} = 10^{-16}$ , it needs only about 5 iterations on average for  $\Delta X > 1/3$ , a simple criterion in testing randomness [8].) So the only thing the eavesdropper can do is to find out the secret key  $\varepsilon_{1,K}$ . The problem of security returns to that of the

symmetric cryptography and, according to our security analysis in Section III, there is no shortcut but to try all the possible values of  $\varepsilon_{1,K}$  in  $[0.95, 1)$  or an even larger range.

In summary, the practical security of PKC only relies on that of the symmetric encryption, both for the PN generators, "K", and the encryptor, "A". Given that there is no systematic cryptanalysis developed for the new cryptosystem, the proposed PKC will be secure.

## VI. DISCUSSION AND CONCLUSION

While the incorporated bit-reverse operation improves the security of the chaos-based cryptosystem to a new level, the adaptation of this cryptosystem for PKC brings new features and advantages for other real applications as well.

- Unlike conventional approaches, the same cryptosystem, Eqs. 1, can be used both as encryptor and PN generators. This feature can bring certain convenience both for security analysis and model design.
- In conventional methods, the transmitter has to store all the PNs in a group and find the private key which matches up the returned public keys by a brute-force comparison, which usually involve large amounts of memory space and computer resource. By adopting "K" as the PN generators, all these keys can be automatically regenerated through the dynamics of OCML. Since the security of PKC relies on the number of sessions transmitted, this property also makes it possible to implement PKC in situations where memory space is scarce and computer speed is limited.
- Although one could replace each lattice in "K" with a separate conventional PN generator, in real applications it is usually hard to keep them working in step. But this problem does not appear for OCML,

where all sequences are outputted simultaneously under the relation of GS.

- The process of recovering the private key  $X_{5,K}(j)$  from the public keys  $X_{i,K}(j)$ ,  $i = 2, 3, 4$ , is achieved by the trap-door  $\varepsilon_{1,K}$ , the only secret of the transmitter. With the trap-door, it is easy to recover all keys of the chosen session, but this fails for any detectable mismatch. In this regard, the proposed OCML actually can be used as a one-way function with the trap-door  $\varepsilon_{1,K}$ .

The proposed PKC also enjoys all advantages of traditional chaotic systems. The security of encryptor "A" can be updated easily either by enlarging its key space or combining more couplings as the session key, which make this scheme easily adjustable to different security requirements. In addition to the implementations on software, the proposed scheme is expected to be efficient on hardware as well, judging from the progress in chaos experiments [25]. The dynamics based cryptography makes it not only easy to formulate and analyze system security in theory, but also simple to design and operate the constructed cryptosystems in applications. Meanwhile, the performance of PKC can be further enhanced by chaos-based spread-spectrum communications [23]. Whereas the security of PKC relies on the number of transmitted sessions, it is highly recommended to transmit these data through a wide-band channel so as to achieve a fast speed, and chaotic signals, with their excellent performance on correlations, can be used for this purpose directly.

In conclusion, we have proposed in this paper a way of improving the security of chaos-based cryptosystem to the order of measure precision, and applied it to PKC by using the system both as PN generators and symmetric encryptor. Incorporating the conventional bit-reverse operation, we successfully overcome the problem of "continuity" in chaotic systems, and equip the conventional scheme of PKC with new characteristics of spatiotemporal chaos.

- 
- [1] L.M. Pecora, T.L. Carroll, Phys. Rev. Lett. **64** 821 (1990).
- [2] T.L. Carroll and L.M. Pecora, IEEE Trans. Circuits Syst. **38**, 453 (1991).
- [3] L. Kocarev, K.S. Halle, K. Eckert, L.O. Chua, and U. Parlitz, Int. J. Bif Chaos Appl. Sci. Eng. **2**, 709 (1992).
- [4] L.M. Cuomo, A.V. Oppenheim, phys. Rev. Lett. **71**, 65 (1993).
- [5] S. Hayes, C. Grebogi, E. Ott, A. Mark, Phys. Rev. Lett. **73**, 1781 (1994); D. Gligoroski, D. Dimovski, L. Kocarev, V. Urumov, L.O. Chua, Int. J. Bif Chaos Appl. Sci. Eng. **6**, 2119 (1996); M.S. Baptista, Phys. Letts. A **240**, 50 (1998).
- [6] G.D. Vanwiggeren and R. Roy, Science **279**, 1198 (1998); Phys. Rev. Lett. **81**, 3547 (1998); J. Garcia-Ojalvo and R. Roy, *ibid.* **86**, 5204 (2001).
- [7] L. Kocarev, U. Parlitz, Phys. Rev. Lett. **74**, 5028 (1995); S. Papadimitriou, A. Bezerianos, and Tassos Bountis, IEEE Trans. Comput. **48**, 27 (1997); M.C. Mackey, L. Glass, Science **197**, 287 (1977); C.M. Kim, S. Rim, and W.H. Kye, Phys. Rev. Lett. **88**, 14103 (2002).
- [8] S.H. Wang, J. Kuang, J. Li, Y. Luo, H. Lu, and G. Hu, Phys. Rev. E **66**, 65202 (2002).
- [9] S. H. Wang, W. P. Ye, H.P. Lu, J.Y. Kuang, J.H. Li, Y.L. Luo, G. Hu, Commun. Theor. Phys. **40**, 57 (2003).
- [10] G. Tang, S. Wang, H. Lü, and G. Hu, Phys. Letts. A **318**, 388 (2003).
- [11] X.G. Wang, M. Zhan, C.-H. Lai, and G. Hu, Chaos **14**,

- 128 (2004).
- [12] X.F. Gong, X.G. Wang, M. Zhan, and C.-H. Lai, *Chaos* **14**, 358 (2004).
- [13] S. Boccaletti, J. Kurths, G. Osipov, D.L. Valladares, and C.S. Zhou, *Phys. Rep.* **366**, 1 (2002).
- [14] G. Perez and H.A. Cerdeira, *Phys. Rev. Lett.* **74**, 1970 (1995); K.M. Short, A.T. Parker, *Phys. Rev. E* **58**, 1159 (1998); C. Zhou, and C.-H. Lai, *ibid.* **60**, 320 (1999).
- [15] G.J. Hu, Z. Feng, R.L. Meng, *IEEE Trans. Circuits Syst., I: Fundam. Theory Appl.* **50**, 275 (2003).
- [16] G. lvarez, F. Montoya, G. Pastor, and M. Romera, *Chaos* **14**, 274 (2004).
- [17] L. Kocarev, *IEEE Circuits syst magz.*, **1**, 6 (2001).
- [18] F. Dachselt and W. Schwarz, *IEEE Trans. Circuits Syst., I: Fundam. Theory Appl.* **48**, 1498 (2001).
- [19] B. Fraser, P. Yu, and T. Lookman, *Phys. Rev. E* **66** 17202 (2002).
- [20] B. Schneier, *Applied Cryptography: Protocols, Algorithms, and Source Code in C*, Wiley, New York (1996).
- [21] R. Tenny, L.S. Tsimring, L. Larson, and H.D.I. Abarbanel, *Phys. Rev. Lett.* **90**, 047903 (2003); R. Mislovaty, E. Klein, I. Kanter, and W. Kinzel, *ibid.* **91**, 118701 (2003).
- [22] R.C. Merkle, *Communications of the ACM*, **21**, 294 (1978).
- [23] X.G. Wang, M. Zhan, C.-H. Lai, and X.F. Gong, (to appear).
- [24] N.F. Rulkov, M.M. Sushchik, L.S. Tsimring, and H.D.I. Abarbanel, *Phys. Rev. E* **51**, 980 (1995).
- [25] A.S. Dmitriev, B.E. Kyarginskii, A.I. Panas, D.Yu. Puzikov, and S.O. Starkov, *Tech. Phys. Lett.* **29**, 72 (2003).