

Using long-baseline interferometric gravitational waves detectors for high precision measures of the gravitational acceleration

Christian Corda

October 8, 2017

INFN - Sezione di Pisa and Università di Pisa, Via F. Buonarroti 2, I - 56127
PISA, Italy

E-mail address: christian.corda@ego-gw.it

Abstract

A derivation of the optical axis length fluctuations due by tilts of the mirrors of the Fabry-Perot cavity of long-baseline interferometers for the detection of gravitational waves in presence of the gravitational field of the earth is discussed. By comparing with the typical tilt-induced noises it is shown that this potential signal, which is considered a weak source of noise, is negligible for the first generation of gravitational waves interferometers, but, in principle, this effect could be used for high precision measures of the gravitational acceleration if advanced projects will achieve an high sensitivity. In that case the precision of the misure could be higher than the gravimeter realized by the Istituto di Metrologia “Gustavo Colonnetti”.

PACS numbers: 04.80.Nn, 04.80.-y, 04.25.Nx

1 Introduction

The design and construction of a number of sensitive detectors for gravitational waves (GWs) is underway today. We have some laser interferometers like the VIRGO detector, being built in Cascina, near Pisa by a joint Italian-French

collaboration, the GEO 600 detector, being built in Hanover, Germany by a joint Anglo-Germany collaboration, the two LIGO detectors, being built in the United States (one in Hanford, Washington and the other in Livingston, Louisiana) by a joint Caltech-Mit collaboration, and the TAMA 300 detector, being built near Tokyo, Japan. We have many bar detectors currently in operation too, and several interferometers and bars that are in a phase of planning and proposal stages (for the current status of gravitational waves experiments see [1, 2]).

The results of these detectors will have a fundamental impact on astrophysics and gravitation physics. There will be lots of experimental data to be analyzed, and theorists will be forced to interact with lots of experiments and data analysts to extract the physics from the data stream.

Detectors for GWs will also be important to verify that gravitational waves only change distances perpendicular to their direction of propagation and to confirm or ruling out the physical consistency of General Relativity or of any other theory of gravitation [3, 4, 5, 6]. This is because in the context of Extended Theories of Gravity we know that some differences from General Relativity and the others theories can be seen starting by the linearized theory of gravity [3, 4, 6].

In this paper we discuss on the possibility of an other use of long-baseline interferometric GWs detectors, giving a derivation of the optical axis length fluctuations due by tilts of the two mirrors of the Fabry-Perot optical cavity in presence of the gravitational field of the earth. By comparing with the typical tilt-induced noises it is shown that this potential signal, which is considered a weak source of noise [7, 8, 9], is negligible for the first generation of GWs interferometers, but, in principle, this effect could be used for high precision measures of the gravitational acceleration if advanced projects will achieve a high sensitivity. In that case the precision of the measure could be higher than the one of the gravimeter of the Istituto di Metrologia “Gustavo Colonnetti” (IMGC) [10].

2 Using laser interferometers like gravimeters

The coupling of angular tilts of the cavity mirrors with interferometer’s imperfections (like non perfect centering of the optical axis on the two mirror rotation centers, interferometers asymmetries and input laser geometry fluctuations) has been long studied like a particular noise source [11, 12, 13]. In next Sections the effect of the coupling of mirror tilts with gravitational earth field will be analyzed, first like a source of noise for GWs interferometers, comparing with other greater noises associated to mirror tilts (that however do not limit the sensitivity of the interferometer) and showing that in the first generation of interferometers this noise is negligible, then the possibility of using this effect for high precision measures of the gravitational acceleration with advanced projects will be discussed.

The possibility of using interferometers like high precision gravimeters is well known in the scientific community. Actually falling corner cube interferometers

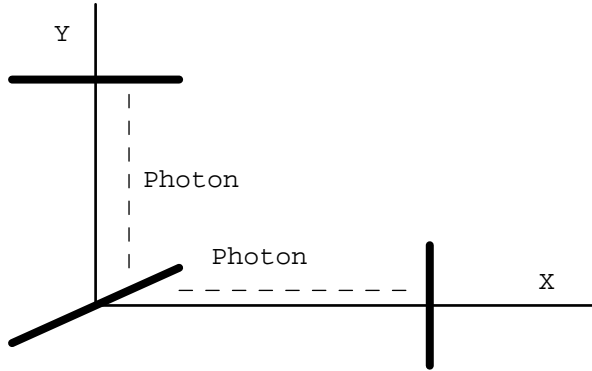

Figure 1: a simple Michelson interferometer: photons can be launched from the beam-splitter to be bounced back by the mirror

are being used for absolute measures of the gravitational acceleration, being the best absolute instruments for this type of measure, because they are based on first principle measures and require no calibration [10, 14]. In particular the gravimeter realized by the IMGIC measures the gravitational acceleration with a sensitivity of $10^{-8}ms^{-2}$ [10]. The instrument, based on symmetric motion, uses one mirror which is free falling in a vacuum chamber. To detect the flight path, a laser interferometer with a sensitivity of $10^{-9}m$ is used [10]. In next Sections of this paper it will be shown that advanced interferometers for the detection of GWs could in principle achieve a better sensitivity for measures of the gravitational acceleration.

3 Effect of tilts in the frame of the local observer

Because we are in a laboratory environment on earth, we typically use the coordinate system in which the space-time is locally flat (see refs. [6, 15, 16, 17]) and the distance between any two points is given simply by the difference in their coordinates in the sense of Newtonian physics. In this frame, called the frame of the local observer, gravitational signals manifest themselves by exerting tidal forces on the masses (the mirror and the beam-splitter in the case of a simple Michelson interferometer, see Figure 1, the input and reflecting mirrors for a Fabry-Perot cavity, like the Virgo interferometer, see Figure 2).

A detailed analysis of the frame of the local observer is given in ref. [15], sect. 13.6. Here we remember only the more important features of this frame:

- the time coordinate x_0 is the proper time of the observer O;
- spatial axes are centered in O;

in the special case of zero acceleration and zero rotation the spatial coordinates x_j are the proper distances along the axes and the frame of the local observer reduces to a local Lorentz frame: in this case the line element reads

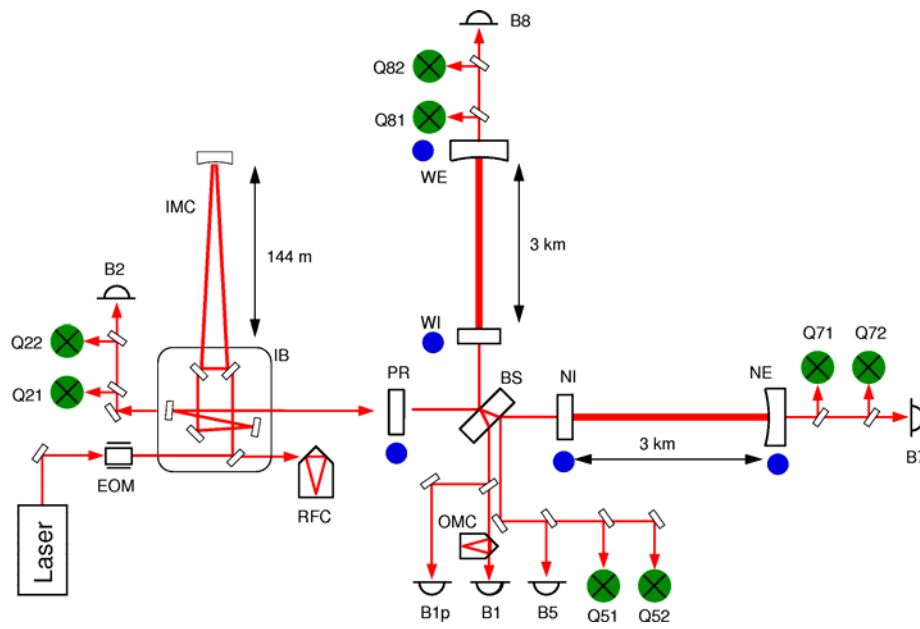

Figure 2: scheme of the Virgo interferometer

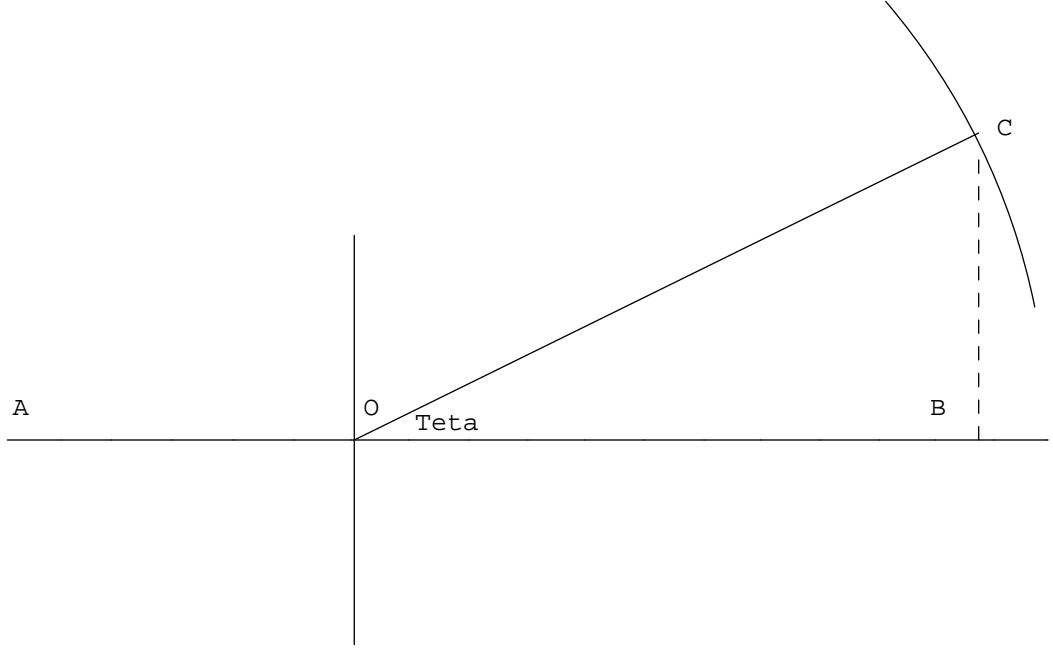

Figure 3: the input and far mirrors of a Fabry - Perot cavity, it is $AB = R$, $OB = L$, $BC = d$ and $OC = L + a$

$$ds^2 = (-dx^0)^2 + \delta_{ij}dx^i dx^j + O(|dx^j|^2)dx^\alpha dx^\beta; \quad (1)$$

the effect of weak gravitational signals on test masses is described by the equation for geodesic deviation in this frame

$$\ddot{x}^i = -\tilde{R}_{0k0}^i x^k, \quad (2)$$

where we have called \tilde{R}_{0k0}^i the linearized Riemann tensor [15].

Let us consider a Fabry - Perot cavity of length L in the x direction (i.e. we are assuming that the arms of our interferometer are in the x and y axes), having the input mirror flat and the far mirror convex of radius $R > L$ (like the Virgo interferometer, see Figures 2, 3).

We are interested in vertical tilts generated by the earth gravitational field (i.e. in the z direction), thus, by putting the origin of our coordinate system in the input mirror (Figure 3) we call θ the tilts of the second mirror around the horizontal axis from the ideal position corresponding to the case of cavity axis lying on line joining the mirror center of rotation. The geometrical effects on the cavity are a first order displacement of the optical axis on the mirror 2 that we call d , and a second order variation of the length l of the cavity (ref. [11] and Figure 3) given by

$$d = (L + a)\theta \quad (3)$$

and

$$l = L + d\theta = L + (L + a)\theta^2. \quad (4)$$

The more general interval in the frame of a local observer is [6, 15, 16, 17]

$$ds^2 = g_{00}dt^2 + dx^2 + dy^2 + dz^2, \quad (5)$$

(i.e. in this paper we work with $G = 1$, $c = 1$ and $\hbar = 1$) where

$$g_{00} = -[1 + 2V(z)]. \quad (6)$$

Equation (6) is the formula which gives the correspondence between Newtonian theory and General Relativity and $V(z)$ is the Newtonian potential of the earth [6, 15, 16, 17].

Let us consider the interval for photons propagating along the x -axis in absence of gravitational tilts [6, 15, 16]

$$ds^2 = g_{00}dt^2 + dx^2. \quad (7)$$

We recall that the y direction can be neglected because the absence of the y dependence in the metric (5) implies that photon momentum in this direction is conserved. We also emphasize that photon momentum in the z direction is not conserved, for the z dependence in eqs. (6) and (5) (see ref. [17] for details). Thus photons launched in the x axis will deflect out of this axis. But this effect can be neglected because the photon deflection into the z direction will be at most of first order [6, 16]. Then, to first order, the dz^2 term can be neglected.

The condition for a null trajectory ($ds = 0$) gives the coordinate velocity of the photons

$$v^2 \equiv \left(\frac{dx}{dt}\right)^2 = 1 + 2V(z = 0), \quad (8)$$

which is a convenient quantity for calculations of the photon propagation time between the two the mirrors [6, 16].

To first order the coordinate velocity is approximated by

$$v \approx \pm[1 + V(z = 0)], \quad (9)$$

with $+$ and $-$ for the forward and return trip respectively. In absence of gravitational tilts the coordinates of the input mirror $x_{m1} = 0$ and of the second mirror $x_{m2} = T = L$ do not change under the influence of the gravitational field of the earth, thus we can find the duration of the forward trip of the light as

$$T_{01} = \int_0^L \frac{dx}{v} \quad (10)$$

where $T = L$ is the transit time of the photon in absence of any gravitational field, i.e. in a Minkowskian spacetime. To first order eq. (10) can be rewritten as

$$T_{01} \approx T - \int_0^T V(z=0)dx = T(1 - V(z=0)). \quad (11)$$

In analogous way the propagation time in the return trip is

$$T_{02} = T - \int_T^0 V(z=0)(-dx) = T(1 - V(z=0)) = T_{01}. \quad (12)$$

The sum of T_{01} and T_{02} give us the round-trip time for photons traveling between the boundaries. Then we obtain the deviation of this round-trip time (distance) from its unperturbed value $2T$ as

$$\delta(2T) = 2T_0 - 2T = -2TV(z=0). \quad (13)$$

Now let us suppose that, in presence of gravitational tilts, the second mirror has a weak motion in the z direction. In this case the mirror 2 rotates by an amount θ which corresponds to a parallel displacement of the optical axis by the quantity

$$\delta(z) \equiv (T + a)\theta = d \quad (14)$$

(see figure 3). Thus, to first order, we can write for the duration of the forward trip

$$T_{*1} \approx T - \left(\int_0^T V(z)dx = T \left[1 - (V(0) + \frac{\partial V(z)}{\partial z} \delta(z)) \right] \right). \quad (15)$$

In this way the time difference $\delta T_1 = T_{*1} - T_0$ between the tilted and unperturbed optical axes can be written as

$$\delta T_1 = Tg(T + a)\theta, \quad (16)$$

where

$$g \equiv -\frac{\partial V(z)}{\partial z} \quad (17)$$

is the gravitational acceleration.

The duration of the return trip is computed as

$$T_{*2} \approx T - \left(\int_T^0 V(z)(-dx) = T \left[1 - (V(0) + \frac{\partial V(z)}{\partial z} \delta(z)) \right] \right) = T_{*1}. \quad (18)$$

Thus, the time difference $\delta T_2 = T_{*2} - T_0$ between the tilted and unperturbed optical axes for the return trip is the same for the forward trip

$$\delta T_2 = Tg(T + a)\theta \quad (19)$$

and we have for the total variation of the round trip proper time of a photon

$$\delta T = \delta T_1 + \delta T_2 = 2Tg(T + a)\theta = 2Tgd \quad (20)$$

We have to recall that experimentalists compute the effect that this variation of the round trip proper time generates in the variation of the phase of the light of the laser in the cavity [9, 14], thus

$$\delta\Phi = \Omega_0\delta T = 2\Omega_0Tgd, \quad (21)$$

is the signal which can be in principle computed with long-baseline interferometric gravitational waves detectors and due to gravitational tilts, where $\Omega_0 = 2\pi f_0$ and $f_0 = 10^{15}Hz$ in the Virgo interferometer.

For the other arm of the interferometer in which the mirrors are located along the y axis of our coordinate system the analysis is parallel to the one above.

In the case of the Virgo interferometer we have $L = T = 3Km$ and, in principle, we can compute distances (times) with a sensitivity of $10^{-18}m$ and angles with a sensitivity of $10^{-9}rad$ [7, 8]. In next section, by comparing with the typical tilt-induced noises, it will be shown that precision measures of the gravitational acceleration are in principle possible with long baseline interferometers with a sensitivity of $10^{-9}ms^{-2}$ that is an order of magnitude higher than the gravimeter realized by the IMGC.

4 Typical error tilt noise in the Fabry-Perot cavity of laser interferometers

The effect of coupling of mirror tilts with the gravitational earth field is a first order effect, while, as it is well known [7, 8], the length variation of a Fabry-Perot axis when mirrors rotate is a second order effect. For an high precision alignment of the axis, the gravitational coupling can overcome the other effects, thus it could generate noise, or, from an other point of view, such an effect could be put in evidence and measure the gravitational acceleration. It is also known that, in principle, a small high-frequencies tilt of angular amplitude $\theta \simeq 10^{-9}rad$ can be detect [7, 8, 9, 13]. But it has to be emphasized that, at least for the first generation interferometers, the alignment of the cavity will not be perfect, and the angular sensitivity will probably grater than $10^{-9}rad$. This is because the application of eq. (4) to gravitational waves interferometers gives an intuitive simplification: interferometers like Virgo potentially detect waves with a frequency which falls in the frequency-range $10Hz \leq f \leq 10KHz$, [6, 7, 8] while typical spectrum of mirror rotations is dominated by static or slowly varying components at frequencies well below $1Hz$. In the range of interest for the GWs detection the Fourier transform of eq. (4) is simply [12]

$$\tilde{l}(f) \approx \tilde{d}\epsilon(f), \quad (22)$$

where \tilde{d} can be approximated with the root mean square of long - term fluctuations of the arm length d defined by eq. (3). Equation (22) allows a

direct comparison of the noise due to coupling of small, high frequency mirror rotations with the gravitational field or with the slowly varying mirror angle position. Indeed the estimated long term fluctuation of the arm is of the order of $\tilde{d} \approx 10^{-5}$ meters, which corresponds to an angular amplitude $\theta \simeq 10^{-5} rad$, while the gravitational coupling generates an angular amplitude $\theta \simeq 10^{-9} rad$. Thus the coupling of mirror tilts with slowly varying angle position is the predominant effect.

In order to perform a first measurement of the gravitational acceleration with long baseline interferometers with a sensitivity higher than the one of the gravimeter realized by the IMG C, the sensitivity should be improved at a level better than $\theta \simeq 10^{-9} rad$ which corresponds to a measure of the “gravitational coupling arm” $\tilde{d}_g \approx 10^{-9}$. This can be made in principle remembering that long baseline interferometers recycle the power by using a particular scheme that is shown in figure 2 (see also refs. [7, 8, 18]). The length of the equivalent cavity, which is constituted by the recycling mirror (PR in figure two) and the Michelson interferometer, is monitored and maintained on resonance by a suitable feedback system. It is possible adding a small high-frequency sinusoidal modulation of tilts ϵ_a while a low-frequency misalignment \tilde{d}_c is present, the length \tilde{l}_c of the recycling cavity will be affected by this geometrical coupling

$$\tilde{l}_c = \tilde{d}_c \epsilon_a, \quad (23)$$

while the effect of the tilts due to the coupling with earth field will be negligible because the short length of the cavity itself. In this way, at the modulation frequency of ϵ_a , the signal will be useful for a good feedback to reduce the arm \tilde{d}_c . Recalling that the sensitivity to recycling cavity length fluctuations is estimated of the order $10^{-18} m / \sqrt{Hz}$ [7, 8, 18] and the bandwidth of the feedback can be about $1 Hz$, with a modulation amplitude of $\epsilon_a \simeq 10^{-8} rad$ a reduction up to $\tilde{l}_c \simeq 10^{-10} m$ can be possible. Then, using the first generation parameters (even if not in the first operation interferometers) in principle a measure of g with a precision of $10^{-9} - 10^{-10} ms^{-2}$ is possible, improving the one of the gravimeter realized by the IMG C. In advanced projects of long-baseline interferometers for the detection of GWs a better sensitivity of the order $10^{-19} m / \sqrt{Hz}$ is expected, thus, using a modulation of $\epsilon_a \simeq 10^{-7} rad$ (which does not lower the interferometer performances) will be in principle possible a measure of g with a precision of $10^{-11} - 10^{-12} ms^{-2}$.

5 Conclusion remarks

The possibility of an other use of laser interferometers for the detection of gravitational waves with a derivation of the optical axis length fluctuations due by tilts of the mirrors of the Fabry-Perot cavity in presence of the gravitational field of the earth has been discussed. By comparing with the typical tilt-induced noises it has shown that this potential signal, which is considered a weak source of noise, is negligible for the first generation of gravitational waves interferometers, but, in principle, this effect could be used for high precision measures of the

gravitational acceleration if advanced projects will achieve an high sensitivity. In that case the precision of the misure could be higher than the gravimeter realized by the Istituto di Metrologia “Gustavo Colonnetti” with a potential precision of $10^{-11} - 10^{-12} m s^{-2}$.

Acknowledgements

I would like to thank Salvatore Capozziello, Maria Felicia De Laurentis and Giancarlo Cella for helpful advices during my work. I have to thank the referees for their interest in my work and for precious advices and comments that allowed to improve this paper. The European Gravitational Observatory (EGO) consortium has also to be thanked for the using of computing facilities.

References

- [1] http://www.ligo.org/pdf_public/camp.pdf
- [2] http://www.ligo.org/pdf_public/hough02.pdf
- [3] Capozziello S - *Newtonian Limit of Extended Theories of Gravity in Quantum Gravity Research Trends* Ed. A. Reimer, pp. 227-276 Nova Science Publishers Inc., NY (2005) - also in arXiv:gr-qc/0412088 (2004)
- [4] Capozziello S and Troisi A - Phys. Rev. D **72** 044022 (2005)
- [5] Will C M *Theory and Experiments in Gravitational Physics*, Cambridge Univ. Press Cambridge (1993)
- [6] Capozziello S and Corda C - Int. J. Mod. Phys. D **15** 1119 -1150 (2006)
- [7] Frasconi F and others (The Virgo Collaboration) - Class. Quant. Grav. **21** 385-394 (2003)
- [8] Punturo M and others (The Virgo Collaboration) - 8th ICATPP proceedings (2003)
- [9] Saulson PR - “ Fundamentals of interferometric gravitational wave detectors” - World Scientific, Singapore - New Jersey - London - Hong Kong (1994)
- [10] Germak A, Desogus S and Origlia C - Metrologia **39** (5), 471-476 (2002)
- [11] Rudiger A, Schilling R, Schnupp, L Winkler W, Billing H and Maischberger K. - Opt. Acta 28 641 (1981)
- [12] Kawamura S and Zucker ME - Appl. Opt. **33**, 3912 (1994)
- [13] Calloni E, Di Fiore L, Di Sciascio G, Milano L, Rosa L, Stornaiolo C - Phys. Lett. A **268** 235-240 (2000)

- [14] Private Communication with the referees
- [15] Misner CW, Thorne KS and Wheeler JA - "Gravitation" - W.H. Feeman and Company - 1973
- [16] Rakhmanov M - Phys. Rev. D **71** 084003 (2005)
- [17] Landau L and Lifshits E - "Teoria dei campi" - Editori riuniti edition III (1999)
- [18] Acernese and others (The Virgo Collaboration) - Astrpart. Physics **21** 1-22 (2004)