

# A Survey of Secure Semantic Communications

Rui Meng<sup>a</sup>, Song Gao<sup>a</sup>, Dayu Fan<sup>a</sup>, Haixiao Gao<sup>a</sup>, Yining Wang<sup>a</sup>, Xiaodong Xu<sup>a,b,\*</sup>, Bizhu Wang<sup>a,\*</sup>, Suyu Lv<sup>c</sup>, Zhidi Zhang<sup>a</sup>, Mengying Sun<sup>a</sup>, Shujun Han<sup>a</sup>, Chen Dong<sup>a</sup>, Xiaofeng Tao<sup>d</sup>, Ping Zhang<sup>a,b</sup>

<sup>a</sup>*State Key Laboratory of Networking and Switching Technology, Beijing University of Posts and Telecommunications, Beijing, 100876, China*

<sup>b</sup>*Department of Broadband Communication, Peng Cheng Laboratory, Shenzhen, 518066, Guangdong, China*

<sup>c</sup>*School of Information Science and Technology, Beijing University of Technology, Beijing, 100124, China*

<sup>d</sup>*National Engineering Laboratory for Mobile Network Technologies, Beijing University of Posts and Telecommunications, Beijing, 100876, China*

---

## Abstract

Semantic communication (SemCom) is regarded as a promising and revolutionary technology in 6G, aiming to transcend the constraints of “Shannon’s trap” by filtering out redundant information and extracting the core of effective data. Compared to traditional communication paradigms, SemCom offers several notable advantages, such as reducing the burden on data transmission, enhancing network management efficiency, and optimizing resource allocation. Numerous researchers have extensively explored SemCom from various perspectives, including network architecture, theoretical analysis, potential technologies, and future applications. However, as SemCom continues to evolve, a multitude of security and privacy concerns have arisen, posing threats to the confidentiality, integrity, and availability of SemCom systems. This paper presents a comprehensive survey of the technologies that can be utilized to secure SemCom. Firstly, we elaborate on the entire life cycle of SemCom, which includes the model training, model transfer, and semantic information transmission phases. Then, we identify the security and privacy issues that emerge during these three stages. Furthermore, we summarize the techniques available to mitigate these security and privacy threats, including data cleaning, robust learning, defensive strategies against backdoor

---

\*Corresponding author. Email: xuxiaodong@bupt.edu.cn; wangbizhu.7@bupt.edu.cn

attacks, adversarial training, differential privacy, cryptography, blockchain technology, model compression, and physical-layer security. Lastly, this paper outlines future research directions to guide researchers in related fields.

*Keywords:* Semantic communication, wireless security, privacy, 6G.

---

## 1. Introduction

### 1.1. Background

As expected by academia, government, and industry, the sixth-generation communication (6G) is envisioned to open a new era of the “Internet of Intelligence” with connected people, machines, things, and intelligence [1]. Although the vision of what 6G should be is still an open issue, candidate key performance indicators, use cases and applications have already been summarized and forecasted by academia, industry, and standardization bodies. The International technology union (ITU) [2] provided the trends, usage scenarios, capabilities, and considerations of ongoing development of the future 6G networks. In addition to the extension of the three major scenarios of 5G, 6G will also support three new scenarios, including integrated sensing and communication, Artificial Intelligence (AI) and communication, and ubiquitous connectivity. Besides, six new capabilities are estimated targets for research of 6G, including coverage, sensing-related capabilities, applicable AI-related capabilities, sustainability, interoperability, and positioning. In conclusion, the emerging services in 6G not only rely on high-speed data transmission but also place higher demands on network intelligence and service diversity.

### 1.2. Semantic Communication (SemCom)

Researchers are currently reimagining how mobile communication systems transmit and utilize intelligence information to fully leverage the potential of AI in 6G. An increasing number of researchers are focusing on incorporating semantic information into wireless communications [3] to address this challenge. Shannon and Weaver [4] stated that communications could be categorized into syntactic, semantic, and pragmatic levels. The syntactic level focuses on accurately transmitting the symbols without considering the desired meaning at the semantic level or the intents at the pragmatic level. On the one hand, Semantic Communication (SemCom) enables the communication agents to extract essential semantic information from the original

data, thereby reducing network transmission pressure and the processing delays for intelligent tasks [5]. On the other hand, SemCom can be considered a form of AI-induced or brain-like communication mechanism, as the communication is based on a “knowledge base” accumulated through continuous learning [6].

According to recent efforts in SemCom, researchers have mainly focused on mathematical theory studies [7, 8, 9], infrastructure frameworks design [10, 11, 12], joint source-channel coding schemes [13, 14, 15, 16, 17], and advanced semantic extraction techniques for different communication modalities [18, 19, 20, 21]. Niu et al. put forward the system framework of semantic information theory based on synonymous mapping for the first time, which revealed the key relationship between semantic information and grammatical information and expanded the scope of classical information theory in SemCom [7]. In addition, Zhang et al. proposed the model division multiple access technology, which can excavate the model information space based on SemCom to realize the purpose of distinguishing users, and can effectively improve the spectrum efficiency for semantic transmission [10]. Furthermore, Wu et al. introduce a vision transformer-based deep joint source and channel coding (DeepJSCC) scheme for MIMO channels, named DeepJSCC-MIMO, which leverages self-attention to optimize feature mapping and power allocation, enhancing robustness against channel estimation errors and improving both distortion and perceptual quality across diverse scenarios [15]. Moreover, Wang et al. introduce the deep video semantic transmission, a novel method for end-to-end video transmission over wireless channels that leverages DeepJSCC to adaptively transmit video semantic features and utilizes a nonlinear transform and conditional coding to optimize bandwidth use across video frames [19].

### *1.3. Secure SemCom*

SemCom adaptively reshapes the core mode of information dissemination by integrating AI and communication technologies, and finally endows itself with endogenous intelligence and native conciseness. However, as SemCom evolves, a multitude of security and privacy concerns are surfacing. Notably, the knowledge base or semantic-related models cached for semantic extraction and recovery must continually adapt to various dynamics, including varying channel conditions, communication objectives, the content of the original information, the nature of communication recipients, network resource availability, and device capability limitations [22, 23, 24, 25]. Additionally, at-

tackers can launch model inversion attacks to deduce implicit information, such as the characteristics of data held by specific nodes, through interactions with targeted semantic-related models [26]. Furthermore, by modeling the semantic transmission process, attackers can decipher the relationship between the original information, the transmitted core semantic content, and the reconstructed information, potentially leading to more severe privacy breaches compared to traditional bit-based communications [27].

In recent years, significant advancements have been made in secure SemCom, driven by various approaches aiming to enhance both privacy and robustness. Tung et al. [28] proposed a framework that integrates encryption directly into the source-channel coding process to protect the privacy of semantic data. This method incorporates adversarial training to prevent attackers from reconstructing the original data under adverse network conditions, thereby enhancing the robustness and quality of semantic transmission. Building on this, Luo et al. [29] combined adversarial training with encryption, enabling the encoder and decoder to accurately recover semantic information even in the presence of attackers. Additionally, Chen et al. [30] introduced model inversion eavesdropping attacks, where attackers attempt to reconstruct original data by intercepting transmitted symbols. To defend against this, they suggested effective countermeasures such as random permutation and substitution to disrupt data continuity and protect semantic integrity. Furthermore, Chen et al. [31] developed SemGuarder, a lightweight and robust wireless SemCom system that combines AES and RSA encryption for secure data transmission.

From a physical-layer security (PLS) perspective, Li et al. [32] developed a deep neural network-based secure SemCom system called DeepSSC, which uses a two-phase training strategy. Similarly, Mu et al. [33] proposed another PLS approach that leverages semantic streams as beneficial noise to interfere with eavesdroppers, optimizing power allocation and decoding order to enhance secrecy. In the realm of learning-based techniques, Liu et al. [34] introduced a method using the soft actor-critic algorithm to optimize power control in covert SemCom. Qin et al. [35] suggested generating a semantic key and employing subcarrier-level obfuscation to strengthen security in static channels. For image transmission, Tang et al. [36] employed signal steganography by embedding private image signals into non-sensitive host images to ensure that only legitimate receivers can extract private data. Lastly, Xu et al. [37] proposed a covert SemCom framework for wireless edge networks that uses a full-duplex receiver to generate artificial noise, thereby

interfering with eavesdroppers.

Expanding on these efforts, a comprehensive survey by Won et al. [38] provides an in-depth exploration of resource management, security, and privacy challenges in SemComs. The survey highlights the unique vulnerabilities of SemCom systems, including encoder or decoder attacks, knowledge base manipulation, and transmission channel security issues. To address these, the authors outline effective countermeasures such as adversarial training, differential privacy, and quantum key distribution. Notably, the survey also emphasizes the importance of semantic-aware metrics and performance optimization techniques to enhance system resilience against eavesdropping, jamming, and semantic noise. This work serves as a foundational reference for integrating robust security and privacy mechanisms into future SemCom systems.

Representative overview/survey papers on secure SemCom are listed in Tab. 1. Won et al. [38] comprehensively review resource management, security, and privacy in SemCom, introducing semantic-aware resource allocation and identifying open research challenges. Guo et al. [24] survey SemCom networks, addressing multi-layered architecture, security, and privacy issues while proposing future directions. E. Sagduyu et al. [39] analyze deep learning (DL)-based vulnerabilities, particularly adversarial attacks, and propose novel models to enhance system resilience. Du et al. [40] revisit wireless security in the Semantic IoT, proposing new metrics like semantic secrecy outage probability and highlighting key differences from traditional IoT. Shen et al. [41] discuss secure SemCom challenges and propose defenses such as zero-knowledge proofs. Yang et al. [42] examine SemCom security fundamentals, emphasizing protection mechanisms for semantic transmission and machine learning (ML) models. Luo et al. [43] review SemCom theories and advancements, focusing on challenges in semantic extraction, compression, and transmission. He et al. [44] introduce a mixture-of-experts model for 6G SemCom, showcasing its success in mitigating heterogeneous attacks and preserving task performance.

Table 1: Representative Overview/Survey Papers on Securing SemComs

Ref.	Publication Year/Type	Major Contributions
[38]	2024/Survey	Offers a comprehensive study focusing on resource management, security, and privacy in SemCom, introducing semantic-aware resource allocation methods and discussing open research challenges to advance the field.
[24]	2024/Survey	Provides an overview of SemCom networks, focusing on its architecture, security, and privacy issues. Proposes a multi-layered architecture from technical to semantic levels and outlines future research directions in enhancing system robustness and privacy protection.
[39]	2023/Survey	Focuses on multi-domain vulnerabilities in DL-based SemCom, particularly adversarial attacks. Proposes adversarial attack models to test system resilience by introducing perturbations at input and channel levels, offering insights on defense strategies.
[40]	2023/Overview	Reviews traditional wireless security techniques like physical layer security and covert communication, and introduces new security metrics for Semantic IoT. Also examines semantic attacks and defense mechanisms, proposing targeted and training-free defenses.
[41]	2024/Overview	Comprehensive overview of security and privacy threats in SemCom, identifying five key requirements for secure communication (data confidentiality, integrity, availability, authenticity, and privacy protection) and suggesting countermeasures.
[42]	2024/Overview	Discusses fundamental challenges in secure SemCom from the perspectives of information security and ML model security, presenting different methods for semantic information extraction (autoencoder, knowledge graph, etc.).
[43]	2022/Overview	Provides a systematic overview of the basic principles and recent advancements in SemCom, highlighting key issues like semantic noise, knowledge base sharing, and semantic matching challenges.
[44]	2024/Overview	Proposes a Mixture-of-Experts (MoE) model-based SemCom system framework to address diverse security threats in 6G, showcasing its effectiveness through case studies and simulations in vehicular networks.

#### 1.4. Motivations

Despite the fact that many researchers concentrate on ensuring the security of SemCom, it is surprising to find that a comprehensive understanding of the state-of-the-art in secure SemCom and its fundamental principles remains elusive. Furthermore, insufficient progress has been made in understanding the security and privacy risks associated with SemCom. Therefore, the primary aim of this paper is to provide a detailed survey of the characteristics and technologies that can be utilized in the field of secure SemCom. We hope that this work will provide researchers with a foundational understanding and inspiration to further advance the development of SemCom.

#### 1.5. Contributions

The contributions of this paper are summarized as follows:

- Initially, we provide an overview of SemCom architecture from both link and network levels. The link-level architecture focuses on the joint optimization of each module, while the network-level architecture highlights the transmission process of deep joint source and channel coding (JSCC) models.
- Following this, we outline the entire life cycle of SemComs, encompassing model training, model transfer, and semantic information transmission stages. We follow the measures of security and privacy in AI field, including confidentiality, integrity, and availability, to describe SemCom systems. The security and privacy challenges in these stages include: 1) model training, which faces knowledge base poisoning attacks, gradient leakage, server vulnerabilities, and attacks targeting communication bottlenecks; 2) model transfer, which is susceptible to model slice attacks; and 3) semantic information transmission, which is vulnerable to semantic adversarial attacks, semantic eavesdropping attacks, semantic inference attacks, and semantic jamming attacks.
- To counteract these security and privacy threats in SemCom, we summarize various defense technologies. These include: 1) data cleaning to address dirty data that may introduce noise, missing values, or inconsistencies; 2) robust learning to enhance the resistance of DL models to noise or input disturbances; 3) defensive methods against backdoor

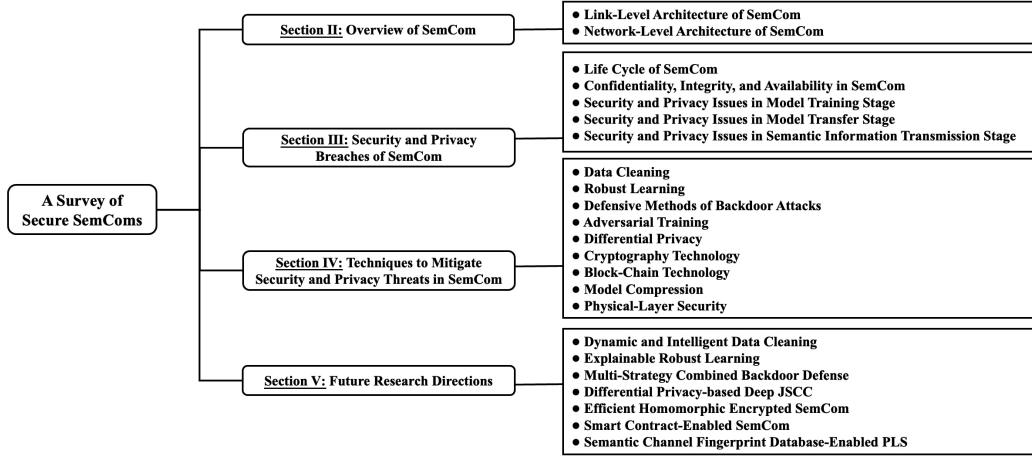

Figure 1: Organizations of this paper.

attacks, provided from both data and model perspectives; 4) adversarial training, approached from sample generation and model optimization angles; 5) differential privacy, which introduces noise into the data to prevent attackers from accurately restoring individual information; 6) cryptography technology, further classified into homomorphic encryption, secure multi-party computation, trusted execution environments, and secure aggregation; 7) blockchain technology, which combines data blocks into a tamper-proof and unforgeable chain structure; 8) model compression, further categorized into model pruning, parameter quantization, low-rank decomposition, and knowledge distillation; and physical-layer security, which includes beamforming, artificial noise, relay cooperation, intelligent reflecting surfaces, physical-layer key generation, and physical-layer authentication.

- Furthermore, we point out the future research direction, including dynamic and intelligent data cleaning, explainable robust learning, multi-strategy combined backdoor defense, differential privacy-based deep JSCC, efficient homomorphic encrypted SemCom, smart contract-enabled SemCom, and semantic channel fingerprint database-enabled PLS.

### 1.6. Organizations

As illustrated in Fig. 1, the rest of this paper is organized as follows. Sec. 2 overviews the link- and network-level architectures of SemCom. Sec.



3 provides the security and privacy violation issues during each stage of SemCom. Sec. 4 provides insights into existing defense mechanisms to enhance the security and privacy of SemCom. Sec. 5 looks forward to the future research direction. Finally, Sec. 6 concludes this paper. The acronyms used in this paper are listed in Tab. 2.

Table 2: List of Acronyms Used in the Paper

Abbreviations	Full Name	Abbreviations	Full Name
AI	Artificial Intelligence	MEC	Mobile Edge Computing
CNN	Convolutional Neural Network	MIMO	Multi-Input Multi-Output
DL	Deep Learning	Non-IID	Non-Independent and Identically Distributed
DNN	Deep Neural Network	PHE	Partially Homomorphic Encryption
DP	Differential Privacy	PLA	Physical-Layer Authentication
FFT	Fast Fourier Transform	PLKG	Physical-Layer Key Generation
FL	Federated Learning	PLS	Physical-Layer Security
FHE	Fully Homomorphic Encryption	QoS	Quality of Service
GAN	Generative Adversarial Network	SMPC	Secure Multi-Party Computation
HE	Homomorphic Encryption	SemCom	Semantic Communication
IRS	Intelligent Reflecting Surface	SNR	Signal Noise Ratio
JSCC	Joint Source and Channel Coding	SGE	Software Guard Extensions
ML	Machine Learning	TEE	Trusted Execution Environment

## 2. Overview of SemCom

This section first compares the traditional communication and SemCom systems from the perspective of link-level architecture, and then introduces

the model generation and transmission in SemCom from the perspective of network level.

### 2.1. Link-Level Architecture of SemCom

Fig. 2(a) depicts the link-level architecture of the traditional communication system, where each module is separately designed and independently optimized. The information source is independently processed by the source encoder and the channel encoder, then transmitted via the physical channel, where a hard matching is occurred. After that, the noised signal is obtained at the receiver side and processed by the channel decoder and the source decoder. Traditional communication systems focus on the accurate replication of digital bits through the transmission of analog waves in the air, where the wireless channel is viewed as an opaque data pipe carrying messages. The contextual meaning and the validity of the messages are ignored, and the only requirement is to recover the transmitted bits as accurate as possible at the receiver space without considering the desired meaning or downstream actions. In this circumstance, a large amount of semantically irrelevant redundant data will be transmitted together, which causes unnecessary communication resource consumption.

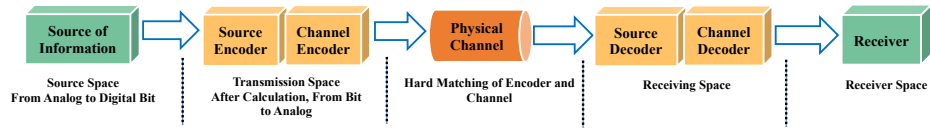

(a) Traditional communication: each module operates independently.

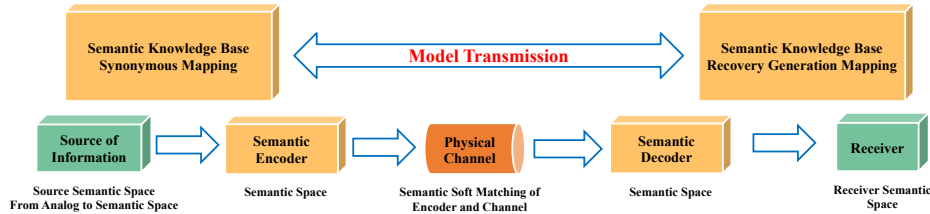

(b) SemCom: optimization of modules in the same semantic space.

Figure 2: Comparison of the link-level architecture between traditional communication and SemCom systems.

Fig. 2(b) demonstrates the link-level architecture of the SemCom system, where AI models and abundant data samples are treated as the semantic

knowledge base providing synonymous mapping between information source and semantics. As can be trained by distributed data samples and transmitted throughout the network (see Sec. 2.2), the AI model can perform efficient SemCom for semantic information generation and recovery on the transmitter and the receiver side [45], thereby enabling the joint training and deployment of the semantic encoder and the semantic decoder.

As shown in Fig. 2(b), the information source is directly processed by the semantic encoder in the semantic space, which aims to extract the contextual meaning of the input message. Then the extracted semantic symbols are passed into the physical channel, where the semantic soft matching is achieved to adapt to both the source information and the channel noise. At the receiver side, the noised semantic symbols are further processed by the semantic decoder, which recovers the source information under the joint consideration of channel noise and the received semantics. Since the semantic encoder and the semantic decoder are jointly trained under the semantic space and adapted according to the propagating channel environment, it eliminates the environment’s effect on source information recovery facilitation under the receiver semantic space. It is noted that the multi-modal or heterogeneous original information requires combining other technologies such as semantic synthesis of multiple sources to deliver the desired meaning and match the transmission goal efficiently.

## 2.2. Network-Level Architecture of SemCom

Based on the SemCom framework at the link level, this subsection gives a detailed description of the semantic collaboration at the network level. As illustrated in Fig. 3, inspired by the cloud-edge-device architecture proposed to handle massive data transmission under different application scenarios (e.g., constrained energy availability and low latency tolerance limits) [46], the knowledge collaboration of the SemCom system applies the three-layer architecture as well. Unlike other SemCom systems proposed in [47, 48, 49], which employ a cloud-based knowledge base to achieve semantic extraction and recovery remotely, the semantic collaboration framework aims at the replication of “functions” via transmitting the AI models through the communication system to enable the “flow of intelligence” [50]. The semantic collaboration procedure in each layer is illustrated as follows:

- The functional nodes on the first layer (cloud) consistently generate highly effective models trained on vast databases collected in a distributed manner, ensuring remarkable efficiency, accuracy, robustness,

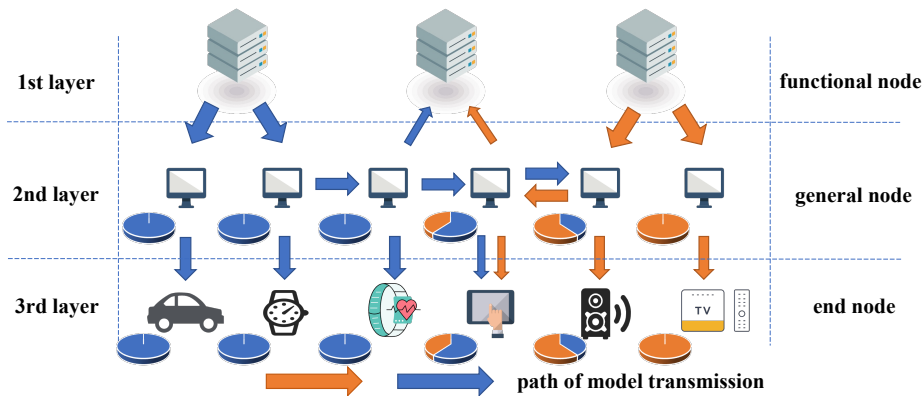

Figure 3: Network-level architecture of SemCom systems.

and reliability. For instance, Google’s servers host advanced models like the Switch Transformer, exemplifying state-of-the-art performance in natural language processing [51]. Moreover, large language models (LLM) provided by AI companies including OpenAI’s ChatGPT and Anthropic’s Claude can also be deployed in the cloud to offer intelligent semantic parsing and generation services [52]. Additionally, cloud platforms can utilize incentive mechanisms, such as blockchain-based reward schemes, to encourage user engagement and contributions to these large AI models.

- The nodes with medium calculation and storage capability, such as mobile edge computing (MEC), can be placed on the second layer (edge). Upon receiving the model from the functional nodes in the first layer, the nodes on the second layer can retrain the model via the techniques such as meta-learning [53], transfer learning [54], knowledge distillation [55], model distillation [56] and federated learning (FL) [57] for different purposes. For example, the edge nodes utilize distributed learning techniques to achieve global collaboration across different knowledge base. By leveraging data with heterogeneous semantic distributions from geographically dispersed locations, the collaboration among edge nodes mitigates the impact of biased data samples on AI model performance, thereby constructing a globally consistent semantic knowledge base [57]. Besides, the edge nodes can compress the large AI models from the first layer to varying degrees based on dynamic channel conditions and resource constraints, making it feasible to transmit the AI

models to the nodes on the third layer within the limited bandwidth, storage and computation resources.

- The resources-constrained end nodes on the third layer (device), such as sensors, cannot retrain the model. These nodes can send the model requirement messages to the edge nodes on the second layer or subscribe to the model update for model retrieval and pay the fees according to the model pricing. In the semantic collaboration framework, the semantic recovery model on the receiver side needs to be synchronized with the semantic encoding model held by the transmitter. Thus, the nodes on the third layer should be able to receive the models transmitted from the source directly and update the corresponding model based on the latest version. Additionally, it should also receive the newly retrieval model from the edge nodes or the nodes on the peer level when necessary.

### 3. Security and Privacy Breaches of SemCom

This section first introduces the full life cycle of SemCom, which includes model training, model transfer, and semantic information transmission phases. Then, it elaborates on the potential security and privacy threats that may arise in each of these three stages.

#### 3.1. Life Cycle of SemCom

As illustrated in Fig. 4, the whole life cycle of SemComs includes the following process.

- (1) Model training on cloud server.
- (2) Model transfer from cloud server to edge server.
- (3) Model and model slice transfer among edge servers.
- (4) Model co-training among edge servers.
  - (a) Local training on edge servers.
  - (b) Model update fragmentation and transfer.
  - (c) Model aggregation.
  - (d) Shared global model fragmentation and transfer.
- (5) Model transfer from cloud server to end node.
- (6) Model update request and model re-training (back to (3)).
- (7) Semantic Information Transmission.

The aforementioned process of SemComs life cycle can be summarized into the following three key phases.

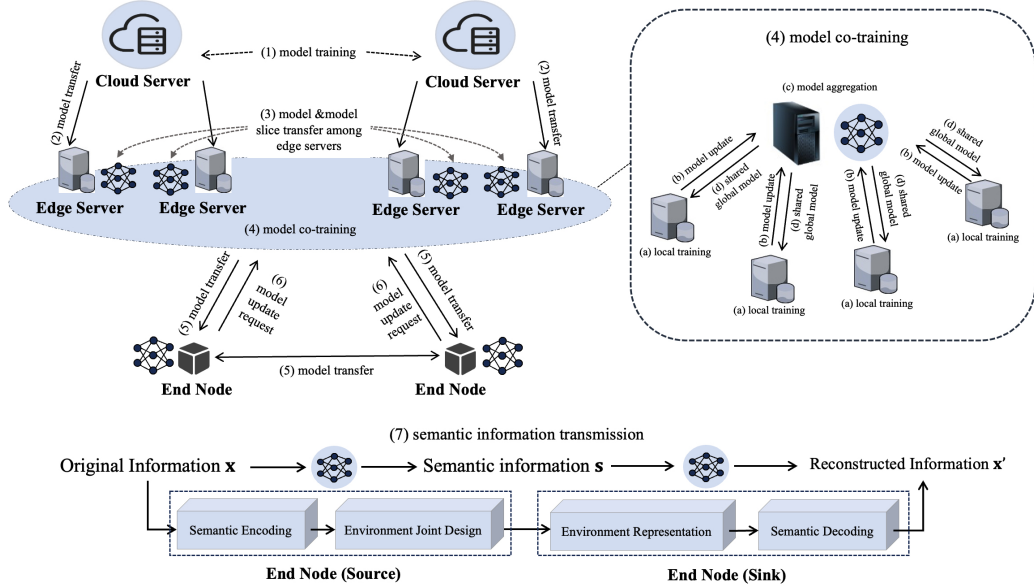

Figure 4: Life cycle of SemComs.

*Phase 1: Model Training.* In the model training phase, various methods such as FL and distributed learning can be utilized. In the case of FL, each edge server or device performs training locally and periodically uploads model parameters or training gradients to the cloud server for aggregation or model updates, facilitating collaborative training across multiple data sources. Uploading model parameters reduces the frequency of data exchanges, but unencrypted transmission of the model may also increase the risk of privacy breaches [58]. On the other hand, uploading gradients can effectively protect data privacy, but it requires frequent data exchanges, thus increasing network load [59]. Additionally, distributed learning allows multiple computing nodes to independently process data and perform model training, thereby more effectively utilizing computing resources distributed across various locations to accelerate the training process [60].

*Phase 2: Model Transfer.* In the model transfer phase, sharing models between different network nodes can be optimized through techniques such as parameter passing, model splitting, or model compression. Model slicing, a common approach, involves dividing a large model into smaller segments for transmission across the network, which helps to reduce bandwidth requirements [61]. Moreover, techniques such as model pruning, parameter quantization, low-rank factorization, and sparsification can be employed to reduce the model size and resource occupancy, thus enabling efficient model

transmission [62]. Additionally, mechanisms for model exchange and model sharing between edge servers can also be used to expedite the model update process across nodes [63].

*Phase 3: Semantic information transmission.* In the semantic information transmission phase, the model processes data through online inference, transmitting only the semantic features. This stage can utilize online inference methods based on attention mechanisms, knowledge distillation, or incremental learning to extract the most semantically significant information from the data. Attention mechanisms enhance the precision of extracting important information, while knowledge distillation helps reduce the complexity of inference, making it suitable for resource-constrained devices [64, 65]. By employing methods of semantic information transmission, it is possible to reduce bandwidth while maintaining the effectiveness and contextual relevance of the transmitted information, meeting the demands of real-time communication.

### *3.2. Confidentiality, Integrity, and Availability In SemCom*

#### *3.2.1. Confidentiality*

In information security, the break up of confidentiality refers to the release of unauthorized information [66]. The confidentiality threat sometimes extends to the information content inference from the observed pattern during traffic analysis [66]. In the AI-enabled traditional communication systems, confidentiality is roughly treated as the system’s privacy, which protects sensitive information against misuse and authorizes access [67]. As stated in [67], confidentiality-related attacks generally can be divided into two classes, namely, data breaches and model extraction. Data breaches are defined as disclosing sensitive data in unauthorized access [67]. Take re-identification as an example. The authors in [68] presented the possibility of identifying medical records via exploiting the dataset from the public electoral rolls of the city of Cambridge. Model extraction refers to the attacks that aim to infer the property of the record used to train the model [69, 70] and even cloning the model directly by observing the input and the output pairs [71, 72].

As shown in Fig. 3, the model trading and model transmission among the functional, general nodes and end nodes in the SemComs enable the ‘flow of the intelligence’ and the data breaches and model extraction attacks like in the AI-enabled traditional networks. This article addresses that more

considerations are necessary during the model transmission process to ensure the model confidentiality and data privacy in SemComs.

### 3.2.2. Integrity

In AI-enabled traditional networks, integrity refers to the consistency and accuracy of data through the AI system workflow against unauthorized modification [67]. An attacker may modify the system towards misclassification and yet does not affect the performance of the systems, such as evasion attacks and backdoor attacks [73, 74, 75, 76, 77].

Despite the attacks targeted on the complete model mentioned above, the attackers in the SemComs can also target the modifications of the transmitted model slices. For example, the malicious node can send the minimally modified models and parameters in a federated setup, such as using an appropriate linear layer and ReLU activation if it knows the cumulative distribution function of some quantity associated with user data [78]. Under such a case, the attacker can directly recover the part of the trained data via monitoring the gradient updates' response from the victim [78]. Moreover, the semantic information, which considers the meaning and veracity of source information [77], is a good choice for attackers to use.

### 3.2.3. Availability

In the AI era, availability can describe the system's power to perform to achieve the expected purpose-designed for the AI system with reliable outputs [67]. For example, the data poisoning attack that alters the boundaries of the classifier such that the model becomes useless can be treated as a classic availability attack in the AI era [67].

In addition to the attacks in the AI-enabled traditional networks, the availability-related attacks in information security also threaten the security of SemComs. Data availability ensures the accessibility of the data and the system to the authorized users whenever they are needed [66]. Typical availability issues include non-malicious issues like hardware failures, unscheduled software downtime, human error, or malicious issues like cyber-attacks and insider threats [79].

In SemCom, model availability attacks disrupt model or model updates transmitted to authorized users. For instance, attackers can access many compromised nodes to set up attack armies, then send the meaningless model update to the model-assembling node, resulting in performance degradation.



Besides, the malicious nodes can launch DDoS-alike attacks to disrupt legitimate users' access to the targeted models when the receiver attempts to get the latest model for semantic recovery.

### *3.3. Security and Privacy Issues in Model Training Stage*

As detailed in Section 2.2, the semantic recovery model on the receiver needs to be synchronized with the semantic encoding model held by the receiver. Thus, the receiving nodes on the second layer can receive the model transmitted from the source directly and update the model based on the latest model and the newly retrieval model sent from the functional nodes or the nodes on the peer level when necessary. As for the receiving nodes allocated on the third layer, the nodes can receive the well-trained model sent from the source or the edge nodes on the second layer.

By employing AI technology, such as meta-learning [80], transfer learning [81], knowledge distillation [82], model distillation [56] and FL [83], the model training and model update can be achieved through sharing the model parameters without revealing raw personal data. Nodes on the second layer can train their local model and send the local model updates to a server or a distributed ledger, followed by the global model aggregation and the dispensation of the latest updated model to the collaborative peer nodes.

However, similar to AI-equipped networks, the model training and update process also faces security and privacy issues even when there is no need for raw data collection [84]. Besides, the close relationship between the original information, the semantic information extracted by the semantic encoding model and the recovered information by the semantic decoding model in SemCom systems, poses new challenges and opportunities for security and privacy detection, as follows.

#### *3.3.1. Knowledge Base Poisoning Attacks*

Each edge server has access to the training data during the collaborative training process, leading to a high possibility of adding the malicious model updates to the global model [85]. In addition, no training samples and training process will be released to and checked by trustworthy authorities [86]. Therefore, attackers can explore the lack of transparency in the agent updates to perform the data poisoning attacks or model poisoning attacks [87].

*Data poisoning attacks.* Malicious clients can generate dirty samples to train the global SemCom model to produce falsified model parameters and send

them to the server [85]. The most commonly used data poisoning strategy is label-flipping [88], where the label of training samples is modified to another category, resulting in taking control of the client’s local models and ultimately manipulating the global model [85]. The objective of the data poisoning attacks is generally to degrade the accuracy of learning tasks, increase the convergence time of the global model, and the probability of erroneous learning results [89].

*Model poisoning attacks.* Unlike data poisoning attacks, model poisoning is designed to poison the global model in a targeted manner by compromising a small number of malicious agents [87]. Instead of using fake data, the model poisoning attackers directly target the global and attempt to ensure the global model converges to a point with good performance on the test or validation data but misclassify a set of chosen inputs with high confidence [87]. For example, the malicious classifier trained in [90] identifies the stop signs like speed limits when a special sticker is added to the stop sign without affecting classification accuracy on other images. Model poisoning attacks are more effective and challenging to explicate than data poisoning attacks [91, 87, 92]. On the one hand, the poisoned model is equally accurate on the FL task, making it stealth to the detection algorithms that rely on the performance verification. Attackers can also incorporate evasion of anomaly detection into the attacker’s loss function to enable the maliciously trained model to evade even relatively sophisticated detectors, e.g., those that measure cosine similarity among submitted model updates. On the other hand, the researchers find that the poisoned model suffers from a longer-lasting performance degradation even when the model has later retrained for another task [90].

*Backdoor attacks.* Backdoor attack is a special kind of backdoor attacks. According to the attacking scenarios, backdoor attacks can be divided into one-time (single-shot) and continuous (multiple-shot) poisoning settings [93]. The continuous poisoning attackers [87] can train the models on backdoored inputs and change the local learning rate and the number of local epochs to maximize the overfitting of the backdoored data. As the global aggregation generally cancels out most of the backdoored model’s update, namely catastrophic forgetting, the multiple-shot attackers need to participate in every round of global aggregation to maintain the backdoor accuracy [91]. While the one-time poisoning strategies are generally effective if staged by a single

participant in a single round by applying the model replacement method to ensure that the attacker’s contribution survives averaging [91]. In addition, backdoor attacks can be divided into centralized and distributed backdoor attacks. The centralized attackers embed the same global trigger pattern in all malicious agent while the distributed attacker decomposes the global trigger pattern into local patterns and embeds them in the different parties [93]. Since the local trigger pattern is more insidious and easier to bypass the robust aggregation rules, distributed backdoor attacks are more effective and stealthy [93].

### 3.3.2. Gradient Leakage

Zhu et al. [94] found that it is possible to obtain the private training data from the publicly shared gradients. The normal participant calculates the gradient to update parameters using its private training data. In contrast, the malicious attacker updates its dummy inputs and labels with the goal of minimizing the gradients distance. When the optimization finishes, the evil user is able to steal the training data from the victims [94]. Following the gradient leakage from gradients algorithm proposed in [94], several improved versions [95, 96] are proposed to solve the convergence difficulties and relax the assumptions such as the batch size, the scale of the data set and the complexity of the target model. For example, Zhao et al. [95] demonstrate that when the targeted model uses cross-entropy as the objective function, the signs of the last-layer weights of the correct and wrong labels are opposite, enabling consistently discovering the ground-truth labels and facilitating the data extraction with increased fidelity.

Gradient leakage algorithms can also be applied to steal private data from the shared gradients in SemCom networks. The attacker can update the dummy input and output to minimize the gradient distance. The dummy output is the same size as the dummy input during the deep JSCC model training instead of a class probability vector during the classification model training. However, gradient leakage-alike attacks are limited in the scope of the batch size, the resolution of the data, and the model’s complexity, leaving some to conclude that data privacy is still intact for realistic training regimes [94, 78]. Despite the difficulty of stealing data in realistic training regimes, the deep JSCC model’s collaborative training procedure may lead to a deeper and easier privacy leakage. Through modelling the relationship among the original information  $x'$ , the semantic information  $x'$  extracted by the encoding module, and the reconstructed information  $y'$  outputted from

the decoding module, denoted as  $f(x', s', y')$ , the gradient approximation process can be expressed as

$$\begin{aligned} \mathcal{D} &= \|\nabla W' - \nabla W\|^2 \\ \text{s.t. } &x', s', y' \sim f(x', s', y'). \end{aligned} \tag{1}$$

The gradient approximation process is executed under the constraint of  $f(x', s', y')$ , narrowing the approximation space and simplifying the whole approximation process. Although the modelling of SemCom systems is still in its infancy, the deeper privacy leakage breaches in SemCom needs to be taken into account seriously.

### 3.3.3. Vulnerability of Servers

In the process of federated training for SemCom models, the edge server is responsible for securely aggregating the parameters updated by local users into the global model parameters, and then returning the updated parameters to the local users. If the server’s security is inadequate, attackers may directly access the global model from the server, further tampering with the model or extracting sensitive information, which poses a serious threat to the integrity and accuracy of the SemCom model [97]. The server is also responsible for receiving local model updates from various clients and aggregating them to generate a new global model. If the server is attacked during this process, it may lead to tampering with the model updates, thereby affecting the training effectiveness and performance of the global model. The server can control when each client accesses and manipulates the model during the FL training process. Therefore, a malicious server can predict the model’s average or worst-case attack sensitivity, thereby designing the lowest-cost attack schemes. The security of network environments in which the server operates is also crucial. If the server operates in a dangerous network environment, the likelihood of being attacked will significantly increase [85].

### 3.3.4. Attacks Against Communication Bottlenecks

During the SemCom model federated training process, there is a frequent necessity to transmit model parameters or update information between servers. As DNNs evolve, models have become increasingly intricate, with a substantial increase in the number of model parameters that change during each iteration, thereby significantly elevating communication overhead. Furthermore, limited network bandwidth can lead to delays for edge servers when

uploading local model updates to the cloud server or downloading the global model. When these delays become excessive, edge servers may fail to complete communication within the specified timeframe, resulting in dropout. The variability in data distribution and format across heterogeneous devices further complicates model training and increases communication overhead. During data transmission, additional processing steps may be required to ensure data consistency and accuracy, which can also prolong communication time. The aforementioned issues are collectively termed as attacks against communication bottlenecks [85, 97]. Despite their infrequent occurrence, the consequences they trigger can be severe, potentially causing significant disruptions to the federated training environment of SemCom models.

#### *3.4. Security and Privacy Issues in Model Transfer Stage*

As shown in Fig. 3, the model updates are shared among collaborative training participants while the latest model travels through the network to the receiving nodes for semantic recovery. Like the packet transmission, the communication systems impose very different upper limits on the size of packets that they can accept and transport [98]. At the same time, the ongoing of artificial intelligence has led to surprising emergence that results from the scale [99]. For example, the introduction of transformer structure [100] made the DL model parameters exceeded 100 million in 2017. While the BERT network model [101] was introduced, making the number of parameters exceed 300 million scales for the first time, the GPT-3 model [102] exceeded 10 billion, and Pengcheng Pancake [103] achieved a scale of 100 billion densities. The introduction of the Switch Transformer [104] surpassed the trillion scale in one fell swoop.

Constrained by the network capacity, the AI model needs to be broken up into smaller fragments for transport and then reassembled when entering the receiving node, a process usually known as fragmentation [99]. Inspired by the works to deal with AI-related tasks in real-time with bandwidth, computational capability, memory and delay limit via splitting the model [105, 106, 107, 108], model partitioning is adopted in SemCom systems. In detail, the model is partitioned as a sequential connection of several layers and then encapsulated into packets for transmission throughout the network.

##### *3.4.1. Model Slice Attacks*

During the transmission of model slices [61], if the isolation measures between them are not sufficiently rigorous, attackers may capitalize on this

vulnerability to steal sensitive information contained within the slices, including model parameters and structures, ultimately launching attacks on the model. Moreover, uneven resource allocation can potentially spark DoS attacks, where attackers block slice transmission channels by consuming substantial resources, thereby preventing model slices from reaching the receiving node as intended and disrupting the overall system operation [109]. Furthermore, virtual network functions are susceptible to risks of unauthorized access and tampering [110]. If attackers successfully penetrate the network’s security perimeter and illegally access or tamper with the slices, it will severely undermine the security and confidentiality of the slice environment, resulting in the failure of the model to be accurately reassembled or executed at the receiving node.

### 3.5. Security and Privacy Issues in Semantic Information Transmission Stage

As depicted in Fig. 4, the extracted semantic information is communicated between the transmitter and the receiver in SemCom networks. Compared with raw data-based communication, privacy properties of SemCom degrade much more grace if the security mechanisms fail [49].

Take asymmetric key encryption as an example. A crypto-system must make it impossible for a computationally-bounded adversary to derive meaningful information about a message from (plain text) using only its cipher text and the corresponding public encryption key [111]. In other words, the adversary chooses two plain texts  $m_0, m_1$ , one of which is encrypted as  $c \leftarrow E(k, m_i)$ . Then the adversary has to guess which message is ciphered and the encryption is semantically secure if for all efficient adversaries, the advantage function is negligible [111]. The advantage function  $A$  is expressed as

$$Adv[A, E] = |Pr(M_0 - M_1)| \quad (2)$$

where  $M_i$  represents the event that the adversary A decides that  $m_i$  is ciphered. In SemCom networks, the semantic information  $s_i$  instead of the original data  $m_i$  is transmitted through the network. Thus, the wiretapper has to steal the semantic model *model* via model reverse engineering techniques to obtain  $m_i$ . Thus, in SemCom system, the ambiguity brought by the reconstructed model on the attacker side needs to be considered. And the advantage function mentioned above should be expressed as

$$Adv[A, E, model] = |Pr(M_0 - M_1)| \quad (3)$$

### 3.5.1. *Semantic Adversarial Attacks*

Adversarial attacks mislead learning models by subtly altering input data [112]. These attacks are equally pertinent to SemCom systems, which rely on DL models for the extraction, encoding, and transmission of semantic information. Semantic adversarial attacks are covert and efficient [24]. Attackers can intentionally introduce imperceptible perturbations into the input data, causing the model to make erroneous predictions or exhibit unintended behaviors. These perturbations are barely noticeable to human senses but can exert significant impacts on DL models. Additionally, during the process of SemCom, wireless channels may be susceptible to various interferences and noises, creating vulnerabilities for attackers [113]. By introducing meticulously crafted perturbations into the channels, attackers can disrupt the transmission and reception of semantic information.

### 3.5.2. *Semantic Eavesdropping Attacks*

Wireless channels, which serve as the conduit for signals traveling from the sender to the receiver, are characterized by their openness. This implies that during transmission, signals are not solely received by legitimate receivers but can also potentially be intercepted by nearby devices operating within the same frequency band. This inherent openness makes wireless channels vulnerable to a multitude of noises, interferences, and other unpredictable time-varying disruptions, including those arising from user mobility [114]. Eavesdroppers can capitalize on this openness by employing specialized receiving equipment to capture and analyze signals in transit. Such equipment may encompass high-sensitivity antennas, signal amplifiers, demodulators, and various other tools dedicated to receiving, amplifying, and dissecting wireless signals. In certain instances, eavesdroppers may even deploy sophisticated signal processing techniques, such as signal separation and interference suppression, to boost the success rate and precision of their eavesdropping endeavors. If eavesdroppers obtain access to the semantic decoder, they could potentially decode some or all of the private or sensitive semantic information, even when their channel conditions are substantially inferior to those of the legitimate receivers [36].

### 3.5.3. *Semantic Inference Attacks*

The semantic inference attacker acquires sensitive information pertaining to the training data through queries to the DL model. Despite the fact that

the model does not directly disclose the training data, by scrutinizing its outputs, the attacker can deduce attributes related to the training data, encompassing sample distribution, class information, or even individual training samples. Inference attacks encompass a range of tactics, including membership inference attacks, attribute inference attacks, and quantity inference attacks, among others.

#### *3.5.4. Semantic Jamming Attacks*

In traditional communications, jamming attackers disrupt or impede normal wireless communication processes by emitting targeted interference electromagnetic waves, leading to command failures or communication difficulties. These attackers can utilize specialized radio interference equipment, including jammers and disruptors, to emit such waves. Furthermore, they can exploit naturally occurring electromagnetic interference in the environment (like lightning and solar activity) or interference generated by human factors (such as power lines and industrial equipment) to execute interference attacks [115].

In contrast, semantic jamming attack focuses on interfering with the semantic content of transmitted data, thereby degrading the consistency and quality of the data, and hindering the receiver’s accurate understanding of the intended message. For example, Tang et al. [116] proposes an intelligent jamming framework designed to analyze the security of SemCom systems. The framework introduces a semantic jammer aiming to alter the decoded content semantically from the original, while the receiver aims to correctly decode the semantic information despite the jamming attack. A game model is established between the jammer and receiver, incorporating a GAN-like strategy to optimize their interactions.

## **4. Techniques to Mitigate Security and Privacy Threats in Sem-Com**

In response to the security and privacy threats detailed in Sec. 3, this section provides defensive techniques, including data cleaning, robust learning, defensive methods of backdoor attacks, adversarial training, differential privacy, cryptography technology, block-chain technology, model compression, and physical-layer security. The detailed relationship between them is shown in Tab. 3.



Table 3: The detailed relationship between security and privacy threats and defensive techniques.

Methods	Descriptions	Attacks	Positions of Attacks	Phases of Attacks	Protected Properties
Data cleaning	Data cleaning is used to deal with dirty data that may introduce noise, missing values or inconsistencies	Knowledge base poisoning attacks	Knowledge base	Model training	Integrity and Availability
Robust learning	Robust learning is used to improve the resistance of DL models to noise or input disturbance, thus ensuring the stability and reliability	Knowledge base poisoning attacks	Knowledge base	Model training	Integrity and Availability
Defensive methods of backdoor attacks	Both on the data and model level	Backdoor attacks	Knowledge base and source of information	Model training and semantic information transmission	Integrity and Availability
Adversarial training	Adversarial training is realized by adding adversarial attacks to the training samples	Semantic adversarial attacks and semantic inference attacks	Source of information and physical channel	Semantic information transmission	Integrity and Availability
Differential privacy	Differential privacy interferes with the original data by introducing noise into the data, making it impossible for attackers to accurately restore any individual information from the interfered data	Gradient leakage and semantic inference attacks	Model transmission	Model training and semantic information transmission	Confidentiality
Cryptography technology	Homomorphic encryption, secure multi-party computation, trusted execution environment, and secure aggregation	Vulnerability of servers, model slice attacks, semantic eavesdropping attacks, and semantic jamming attacks	Model transmission, physical channel, and receiver	Model training, model transfer, and semantic information transmission	Confidentiality, Integrity, and Availability
Block-chain technology	Blockchain combine a series of data blocks into a chain data structure in a sequential way, and ensures that these data blocks cannot be tampered with and forged	Model slice attacks, semantic adversarial attacks, semantic eavesdropping attacks, semantic inference attacks, and semantic jamming attacks	Model transmission, physical channel, and receiver	Model transfer and semantic information transmission	Confidentiality and Integrity
Model compression	Model pruning, parameter quantization, low-rank decomposition, and knowledge distillation	Attacks against communication bottlenecks, semantic inference attacks	Model transmission	Model training, model transfer, and semantic information transmission	Integrity and Availability
Physical-layer security	Beamforming, artificial noise, relay cooperation, intelligent reflecting surface, physical-layer key generation, and physical-layer authentication	Semantic adversarial attacks, semantic eavesdropping attacks, semantic inference attacks, and semantic jamming attacks	Physical channel and receiver	Semantic information transmission	Confidentiality, Integrity, and Availability

#### 4.1. Data Cleaning

Dirty data can introduce noise, missing values, or inconsistencies, directly causing semantic misunderstandings and even communication failure [117]. Therefore, the effectiveness of data cleaning is particularly important. Fig. 5 illustrates the use of data cleaning in DL.

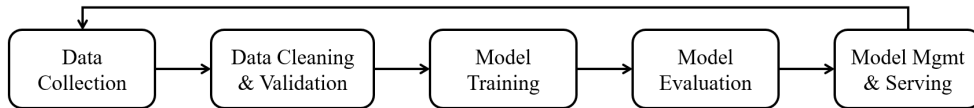

Figure 5: Data cleaning in DL [118].

The below, based on multiple academic studies, delves into various data cleaning methods for different data types and their applications in SemCom.

##### 4.1.1. Intelligent Cleaning of Textual Data

Textual data cleaning focuses on enhancing the accuracy and coherence of text used in SemCom by addressing issues like duplication, inconsistency, and errors. Techniques include deduplication, spelling correction, and missing information imputation, which improve the semantic clarity and reliability of textual datasets in applications like social media analysis and sentiment detection.

**Deduplication and standardization:** Rajan et al. [119] point out that duplicate data significantly impacts the learning efficiency and predictive performance of semantic models. The proposed efficient deduplication method combines hash algorithms and similarity matching (e.g., Jaccard similarity and cosine similarity). This study further optimized text standardization by lemmatization and stemming to eliminate semantic ambiguity, enhancing the model’s robustness when facing diverse expressions. This method has been widely applied in social media data analysis and customer review processing, effectively improving data quality.

**Spelling correction and semantic enhancement:** Ilyas et al. [120] developed a method for spelling correction and semantic enhancement using Generative Adversarial Networks (GANs). Their research demonstrated that GANs could significantly expand datasets by generating diverse text expressions, thus enhancing the model’s adaptability to complex contexts. This method showed exceptional results in legal document processing and multi-lingual corpus analysis, providing strong support for semantic consistency.

**Missing information imputation:** Lee et al. [121] proposed a contextual reasoning-based text completion method that uses generative models (such as GPT) to predict and fill missing words or sentences. Their method performed excellently in sentiment analysis and dialogue systems, effectively improving data coherence and completeness, providing more reliable data for model training.

#### 4.1.2. Diverse Cleaning of Image Data

Image data cleaning refers to the process of reducing noise, correcting artifacts, and enhancing data quality in images used for semantic communication. This includes techniques like noise removal through Gaussian blur and bilateral filtering, which preserve critical features while eliminating distortions. Data augmentation methods, such as rotations and scaling, further improve adaptability to diverse visual scenarios, and GANs can generate synthetic data to address training data shortages.

**Noise filtering and enhancement:** Tang et al. [122] designed an image cleaning method based on Gaussian blur and bilateral filtering. Gaussian blur effectively removes random noise, while bilateral filtering retains edge details while removing low-frequency interference. This method performed exceptionally well in processing medical images, providing high-quality inputs for disease diagnosis and treatment planning.

**Data augmentation:** Whang et al. [123] extended training datasets using data augmentation techniques such as rotation, scaling, and color adjustments to simulate real-world scene variations. Their method was validated in autonomous driving visual systems, significantly improving model adaptability in complex environments.

**GANs:** Ilyas et al. [120] explored the potential of GANs in generating image samples. Their method is particularly useful in situations with insufficient data, generating high-quality image samples to augment datasets and significantly improving model recognition performance for minority classes. This technology has been applied in ecological monitoring and remote sensing image analysis.

#### 4.1.3. Audio Data Denoising and Completion

Audio data cleaning involves removing noise, filling gaps, and enhancing the clarity of audio signals to ensure effective SemCom. Methods such as spectral subtraction combined with DL models are used to isolate speech from background noise. WaveNet-based techniques are employed to restore

missing segments and improve audio fidelity, ensuring reliable performance in real-time auditory applications.

**Denoising and separation:** Chu et al. [117] proposed an audio denoising method combining spectral subtraction and DL models. Their method excelled in voice assistant and multilingual speech recognition systems by separating speech signals from background noise, enhancing the clarity of audio data.

**Signal enhancement and completion:** Rajan [119] used the WaveNet model to complete missing audio segments and combined adaptive filtering technology to enhance the quality of low-sampling-rate audio signals. Their method was successfully applied in remote communication and real-time dialogue scenarios.

#### 4.1.4. *Comprehensive Optimization of Structured Data*

Structured data cleaning ensures logical consistency and integrity by detecting and correcting errors in datasets. Techniques like probabilistic reasoning tools identify and impute missing values, while entity matching algorithms remove duplicate records. These processes are essential for maintaining data reliability in critical fields such as healthcare and finance.

**Outlier and missing value handling:** Lee et al. [121] developed HoloClean, a probabilistic reasoning-based tool for outlier detection and missing value imputation. This tool is particularly suitable for financial and healthcare data analysis and significantly improves data consistency.

**Duplicate record removal:** Rajan [119] developed DeepMatcher, a DL-driven entity matching tool that efficiently identifies duplicate records in large datasets. This tool has been widely applied in e-commerce recommendations and customer relationship management.

**Logical consistency constraints:** Ilyas et al. [120] proposed a dynamic constraint validation method that combines logical rules and ML. By dynamically verifying functional and inclusion dependencies, their method significantly enhances data's logical integrity.

**Lesson 1.** *Data cleaning is essential for SemCom systems as dirty data can lead to semantic misunderstandings and communication failure, and its effectiveness is highlighted by various data cleaning methods for different data types in SemCom, including textual [119, 120, 121], image [122, 123, 120], audio [117, 119], and structured data [121, 119, 120].*

## 4.2. Robust Learning

The design characteristics of FL, as shown in Fig. 6, make FL face numerous challenges in practical applications, such as noise interference, data heterogeneity, malicious clients, and low communication efficiency. These challenges not only hinder the improvement of model performance but also pose higher demands on system robustness and efficiency. This paper reviews recent advances in the robustness of FL and proposes potential directions for improvement.

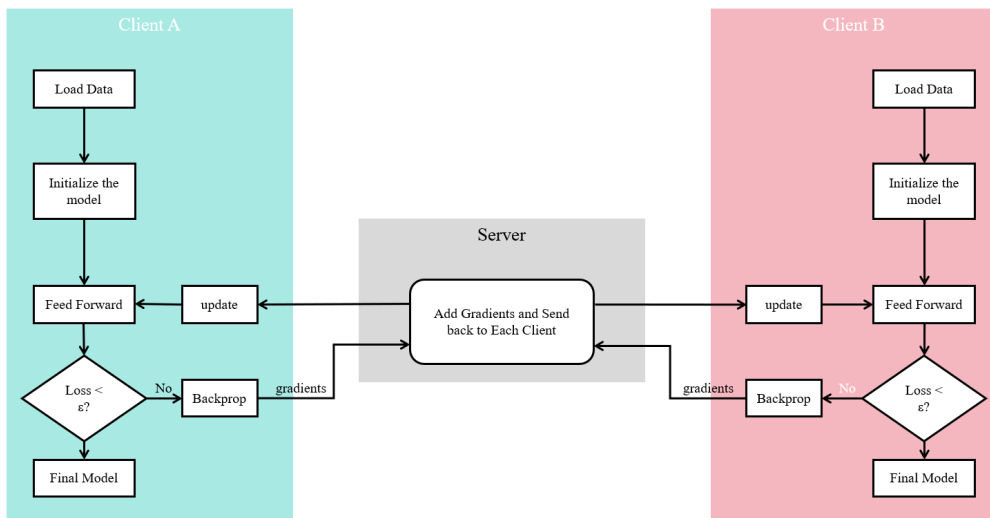

Figure 6: Diagram of FL [124].

### 4.2.1. Robust Aggregation Methods

The model aggregation process in FL is critical as it determines the performance of the global model. However, in the presence of noise, malicious clients, or device failures, traditional methods such as weighted averaging or arithmetic mean are highly susceptible to outliers, leading to significant degradation in the global model's performance. To address this, researchers have proposed a series of robust aggregation methods.

**Geometric median aggregation:** Geometric median aggregation is a classical approach to enhance robustness in high-dimensional spaces. Pilutla et al. [125] introduced a robust federated aggregation method based on the geometric median, leveraging the Weiszfeld algorithm to compute the

geometric median efficiently. This approach successfully mitigates the adverse effects of malicious updates on the global model. Experimental results demonstrate that the proposed method maintains high performance even with a high proportion of malicious clients, showcasing significant advantages in robustness and model accuracy over traditional FedAvg, especially in highly polluted environments.

**Trimmed mean strategy:** The Trimmed Mean method offers a simplified yet effective aggregation strategy by excluding extreme values from model updates, thereby reducing the impact of outliers. Ghosh et al. [126] demonstrated that the Trimmed Mean method performs exceptionally well against Byzantine attacks. By discarding a fixed proportion of maximum and minimum values, this method significantly enhances robustness in adverse environments while avoiding the risk of extreme values disrupting global model updates.

#### *4.2.2. Addressing Client Data Heterogeneity*

The highly non-independent and identically distributed (Non-IID) nature of client data poses a significant challenge to global model training in FL. To accommodate such data heterogeneity, researchers have proposed personalized optimization strategies and client grouping methods.

**Robust heterogeneous FL framework:** Fang et al. [127] developed a Robust Heterogeneous FL framework tailored for heterogeneous data environments. By adaptively adjusting the local training process, this framework enables each client’s model to better align with its unique data distribution. Notably, a noise-tolerant loss function is introduced during local training to alleviate the adverse effects of noisy data on the global model. Moreover, a dynamic weighting mechanism balances the contributions of different clients to global aggregation, thereby improving the robustness of the global model.

**Cluster-based client grouping:** Ghosh et al. [126] proposed a clustering-based method to address challenges associated with heterogeneous data. By analyzing the similarities among local client data, clients with similar distributions are grouped into clusters. Within each cluster, clients share and optimize their local models, effectively mitigating the impact of data heterogeneity. Experimental results indicate that this clustering-based grouping method significantly enhances global model performance in Non-IID data environments.

#### 4.2.3. Mitigating the Impact of Noise and Malicious Clients

To counter malicious clients and noisy data, several mechanisms have been developed to dynamically adjust client contributions, filtering out noise or malicious updates. Fig. 7 illustrates common malicious client attacks in FL.

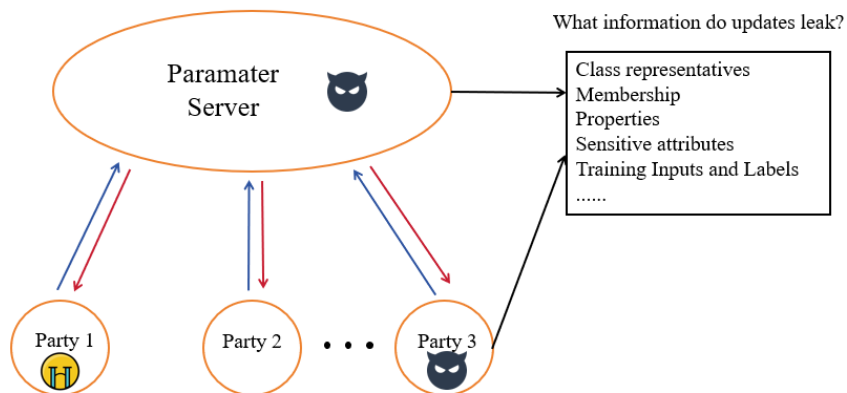

Figure 7: Malicious client attacks in FL [128].

**Client confidence re-weighting mechanism:** Fang et al. [127] introduced a Client Confidence Re-weighting mechanism to dynamically adjust each client’s weight in model aggregation. By evaluating the training quality of each client’s local model on its private data, this mechanism quantifies the actual contribution of each client to global model training. For underperforming clients, their weights are reduced to mitigate the adverse effects of noise and malicious clients. This mechanism not only enhances the robustness of the RHFL framework but also maintains strong model performance in high-noise environments.

**Geometric median-based aggregation and filtering:** Lyu et al. [128] proposed robust aggregation methods based on the geometric median, effectively mitigating the impact of outliers on the model by replacing traditional mean aggregation. Further developments included trimming and filtering mechanisms, such as magnitude clipping of model updates and geometric median-based aggregation, to filter out malicious updates. These strategies significantly improve global model performance and robustness, especially in environments with high proportions of malicious clients.

#### 4.2.4. Balancing Robustness and Communication Efficiency

Communication costs are a critical issue in FL applications. Frequent communication, particularly in scenarios involving numerous devices, can significantly increase bandwidth and energy consumption. Consequently, some studies focus on developing solutions that are both communication-efficient and robust.

**Sparse ternary compression:** Sattler et al. [129] proposed Sparse Ternary Compression, a method specifically designed to reduce communication costs. In this method, model updates are sparsified by selecting only essential parameters for transmission and further compressing data using quantization techniques. This method not only significantly reduces communication overhead per training round but also demonstrates high robustness in Non-IID data environments. Compared with traditional FedAvg, this method effectively balances model accuracy and bandwidth demands, making it highly suitable for resource-constrained settings.

**Worst-case optimization for communication robustness:** Ang et al. [130] analyzed an expectation-based model that incorporates noise into statistical modeling. They designed a regularization approach that introduces noise effects into the local loss function, enhancing the global model’s robustness against communication noise. For worst-case scenarios, researchers adopted sampling and successive convex optimization techniques to address non-convex optimization challenges. Fig. 8 visualises the noise characteristics under two different noise models in 2D space. Experimental results reveal that these designs outperform traditional methods in reducing loss function values and improving prediction accuracy. Additionally, convergence analysis demonstrates that their convergence rates are comparable to centralized learning while maintaining strong model performance under worst-case communication noise.

**Lesson 2.** *Improving robustness in FL requires a multifaceted approach, encompassing optimization of aggregation methods [125, 126], addressing data heterogeneity [127, 126], filtering noise and malicious clients [127, 128], and balancing communication efficiency with model performance [129, 130]. These methods enhance the practicality of FL and lay a solid foundation for its deployment in complex application scenarios. In SemCom systems, these technologies further enhance the efficiency and reliability of distributed model training, supporting the development of more intelligent communication networks.*



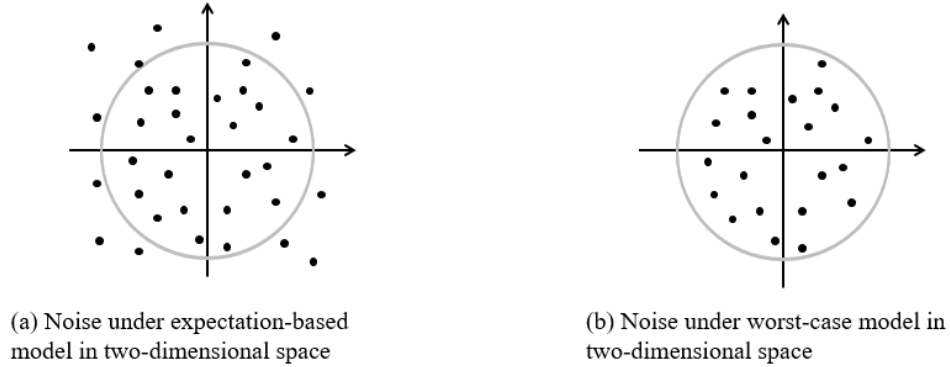

Figure 8: Comparison of noise distributions under the expectation-based model and the worst-case model [130].

### 4.3. Defensive Methods of Backdoor Attacks

As illustrated in Fig. 9, backdoor attacks of DL models are mainly achieved in two ways: one is to adulterate the training data with malicious samples, and the other one is to directly modify the model structure. These operations embed a backdoor in the model, causing the model unusually sensitive to the presence of specific triggers. Extend to SemCom, the attacker can embed triggers to alter the semantic symbols transmitted by the transmitter and modify the symbols in the receiver’s dataset to align with targets and labels of its own choosing, which shows the capability to manipulate the semantics of reconstructed symbols in SemCom. To defend against backdoor attacks, researchers have proposed different defense methods of various focuses at different stages of the model. This section will analyze these methods both on the data level and model level.

#### 4.3.1. Data Processing

For the training phase, the importance of data protection focuses on how the defender obtains training data from external sources. In these cases, an attacker may attack the defender by contaminating the training dataset with malicious samples triggers. If the defender fails to identify these malicious samples and directly uses the data for training, it may lead to backdoor implants in the model. To against the attackers, there are two most direct and effective method based on the training dataset: the first one is to identify and remove the malicious samples in the dataset, while the second one is to reduce the impact of the toxic data, which can prevent the backdoor attack

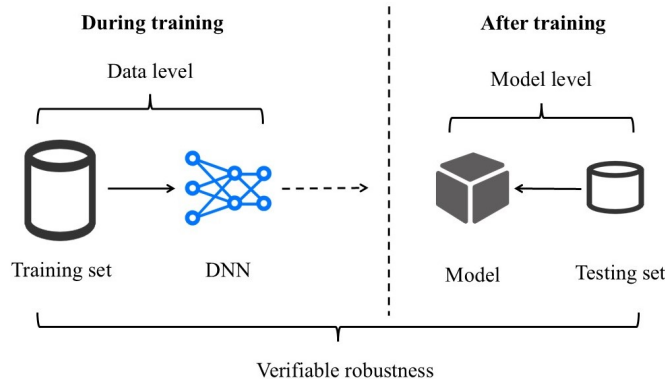

Figure 9: Classification of neural network backdoor defense [131].

effectively. For the inference Phase, the importance of data protection focuses on how to recognize and pre-process the obtained data.

**Filtering Toxic Data:** To filter toxic data, there are three main methods focusing on spectral signatures, clustering and gradient as below.

- **Spectral Signatures based Defense.** One of the effective ways to recognize a backdoor attack is based on its spectral signature. Spectral signature refers to the fact that the samples of a backdoor attack have a distributional difference from the normal samples in the feature representation space, and this difference will be reflected in the spectrum of the covariance matrix. Based on the above theoretical foundation, Tran [132] proposed a detection algorithm based on principal component analysis of spectral signatures. In the trained neural network, a learned representation of each input for each label is extracted. The covariance matrix of these representations is then subjected to a singular value decomposition to obtain a series of eigenvalues and corresponding eigenvectors. The results of the decomposition are used to calculate the anomaly score for each sample, which means the size of the projection of each sample in the direction of the top singular vector of the covariance matrix. The feature representation of a contaminated sample will have a larger projection on one of the principal components of the covariance matrix. In the other words, the samples with the highest scores are the contaminated data points. Then, removing the toxic data and retraining the network can effective against back-

door attacks. However, the above methods have some disadvantages in some aspects. The defense can only be detected when one of the spectral features of the poisoned sample is large enough, otherwise it is not effective to identify the poisoned sample. Hayase [133] proposed a new method to defense against general backdoor attacks, called Spectral Poison ExCision Through Robust Estimation. It estimates the mean and covariance of clean data through robust statistical methods, which makes it possible to accurately estimate the statistical characteristics of normal data even when the data is contaminated. Then the spectral features are amplified by whitening process, and the contaminated samples are removed based on quantum entropy score. Comparing with principal component analysis, the proposed method is able to adapt to different types of backdoor attacks, including the hidden triggers used in some case. It works effectively with a small number of contaminated samples and removes the backdoor completely, which ensures the high efficiency and accuracy in multiple attack scenarios.

- Clustering based Defense. For contaminated datasets, toxic data can be separated from normal data according to cluster analysis. Activation Clustering is a defense method proposed by Chen [134] et al. The key idea is to analyze the activation mode of network for the training data, to determine whether the data is poisoned and which data points are toxic. For each sample in the training set, AC records the activation output of the hidden layer. These activation outputs are flattened into one-dimensional vectors and classified based on their labels. After dimensionality reduction, these vectors are clustered and analyzed into toxic and normal patterns. The data is analyzed by exclusionary reclassification, silhouette score, size comparison and many other ways to filter out the toxic data. Based on the labeled toxic data, the system can further train the model until convergence to achieve the purpose of backdoor repairing. One more clustering approach is Heatmap Clustering proposed by Schulth et al. [135] This method utilizes Explainable Artificial Intelligence techniques, specifically Layer-wise Relevance Propagation, to generate heatmaps. The heatmap shows the correlation between each pixel point of the input sample and the network predictions, which can be visualized as a two-dimensional array where the color shades indicate the strength of the relevance. By calculating the distance between heatmaps, the Differences between different data

points in network decisions are quantified, which helps the model to identify the location of backdoor triggers. The processed heatmaps are categorized using clustering methods to distinguish normal and manipulated data points. Comparing these two clustering methods, Heatmap clustering has a significantly higher computational cost than activation clustering, which is caused by Gromov-Wasserstein to calculate the distances between heatmaps. However, it is more adaptable and robust to different attack patterns and data characteristics.

- Gradient based defense. For the gradient defense approach, Chan et al. [136] use the gradient of the model’s loss function with contaminated inputs to extract signals associated with backdoor attacks. The model assumes that there are specific neurons model that are activated only in the presence of the backdoor trigger. As a result, the weights of these neurons are typically much larger than the weights of the normal one, resulting in a relatively large absolute value of the input gradient at the trigger location having . In this way, toxic and clean samples can be effectively separated in the training model.

**Reducing the impact of toxic data:** Despite of filtering toxic data, backdoor attacks can be resisted by reducing the impact of toxic data, which can be achieved by data augmentation and gradient.

- Data augmentation based defense. Geiping et al. [137] use adversarial training to achieve the aim of data augmentation, extending the adversarial training framework to the defense of poison data. It proposes a defense strategy named Poison Immunity, where adversarial data augmentation involves generating poisoned samples dynamically. These samples intend to imitate the attacks that an attacker might employ. In this way, the model learns to recognize and defend these attacks during the training process. Also, it uses data augmentation including mixup and cutout to create new samples and improve the generalization ability of the model.
- Gradient based defense. Hong et al. [138] mitigate backdoor attacks through gradient shaping. In other words, when facing the threat of data poisoning, it can be observed that there are significant differences in the gradient characteristics, including the magnitude and direction of the gradient, between contaminated and uncontaminated data. To

solve this problem, a gradient shaping technique is employed based on the differential privacy stochastic gradient descent method. Specifically, the technique first limits the magnitude of the gradient through gradient cropping to avoid any individual sample interfering the update of the model parameter too much. Subsequently, it further increases the difficulty for the attacker to manipulate the direction of the gradient by introducing noise into the gradient. According to these measures, even if the training data contains poisoned samples, the parameter updating of the model remains, which cannot be affected significantly by these abnormal samples.

**Filtering toxic data in inference phase:** These defense mechanisms are also capable of screening out toxic samples, but the process takes place in the inference phase of the model rather than in the training phase. Gao et al. [139] proposed a defense system called STRong Intentional Perturbation in response to Trojan attacks. This system performs multiple intentionally perturbations of the input and calculates the prediction of the perturbed input. If the entropy value based on the perturbed inputs is low, it means that the input sample is classification inducing, belonging to a part of Trojan attack, whereby malicious samples can be distinguished from normal samples. Subedar et al. [140] proposed two methods to distinguish clean and poisoned samples by quantifying the uncertainty estimation associated with the training model. The strategy is based on adapting a category-specific probability density function to a deep representation of a DNN, thus constructing a generative model capable of characterizing the deep feature space. During the model testing phase, uncontaminated data samples are distinguished by evaluating the log likelihood values of the deep features of the test samples with respect to these probability distributions. In addition, this study employs the mean-field variational inference technique to infer the posterior probability distributions of the model weights and combines it with the Bayesian inference framework to quantify the uncertainty of the model predictions. Specifically, it utilizes the uncertainty measure in Bayesian active learning to assess the informational reciprocity between the posterior probability distributions of the parameters and the predicted output distributions, which provides a quantitative indicator of the model prediction uncertainty.

**Adding pre-processing module:** Filtering attack data can also be done by introducing a pre-processing module. This approach aims to adjust the trigger properties in the test samples, so that they can no longer match

the activation conditions of the backdoor attack. With this modification, the potential threat of toxic samples can be effectively neutralized. At the earliest, Liu et al. [141] proposed the scheme of connecting a trained self-encoder to the input data as a pre-processor. The trained self-encoder can correctly recognize normal data and generate “failure” commands for toxic data. Qiu et al. [142] proposed the DeepSweep framework to automatically evaluate and generate defense methods against backdoor attacks. The framework performs image transformation by Augmentation Library, and utilizes Inference Transformation Policy in the inference phase to pre-process the samples to disrupt the judgment of the triggers, which in turn corrects the outputs of the toxic samples.

#### 4.3.2. Model Identification and Construction

The model-level based defense approach is mainly applied to determine whether the model is poisoned or not and repair, which is applied after model training. Also, some researchers are denoted to build reliable cyber-security architectures to resist backdoor attacks.

**Identifying poisoning models:** To identify the poisoning model, there are two mainstream method based on trigger and meta-classifier.

- Trigger based defense. The trigger based defense is mainly used to detect and remove malicious triggers hidden in DNNs instead of removing the backdoor directly. Wang [143] proposed a Neural Cleanse approach to design an optimization scheme, which measures the minimum amount of perturbation that converts an arbitrary input sample into a target classification. Based on the measured value of L1 norm, the model finds the malicious triggers and remove them. Based on the idea of trigger defense, researchers also proposed a method to reversely generate the attacker’s triggers with the help of Generative Model. Zhu et al. [144] proposed a framework called GangSweep to generate perturbation mask generation to misclassify the input image using GAN. By simulating the behavior of malicious triggers, GangSweep can identify perturbation masks that can trigger backdoor behaviors, for the specific perturbations could generate specific changes in statistics.
- Meta-classifier based defense. As illustrated in Fig. 10, meta-classifier identifies abnormal pattern by monitoring and analyzing the output of the main classifier. Huang [145] proposed One-Pixel Signature model

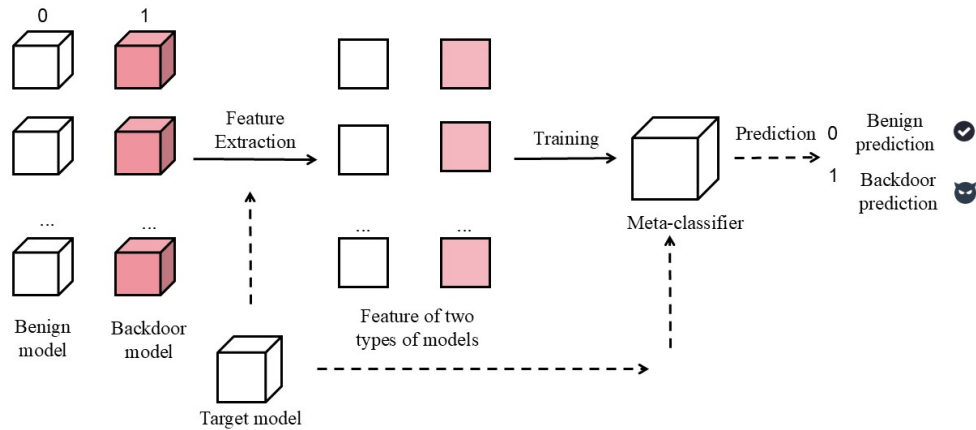

Figure 10: The workflow of meta-classifier defense [131].

based on the principle of meta-classifier. Comparing the one-pixel signature of the clean model and the backdoor model, it can train an outlier detector as a classifier to detect whether a CNN model has been implanted with a backdoor. The meta-classifier makes decisions based on multiple base classifiers to improve the overall classification accuracy through integrated learning methods. It also helps to reduce the risk of overfitting based on the wide range of input data from different models.

**Reconstructing model:** Model reconstruction methods directly target suspicious models to eliminate malicious backdoor. Liu et al. [146] propose a defense method called “Fine-Pruning”, which consists of two methods: pruning and fine-tuning. The principle of utilizing the pruning is to remove neurons that are inactive under normal input data, for these neurons may be utilized by attackers to implant a backdoor. Fine-tuning is based on the principle of tuning the pre-trained model, which depends on adjusting the weights of the local model to mitigate the impact on backdoor attacks. Combining these two approaches, the strategy in this paper can reconstruct the model to effectively resist the backdoor attack. It can not only maintains the accuracy against clean inputs, but also significantly reduces the success rate of the backdoor attack, especially when complex pruning-aware attacks occur. To purify deep neural networks contaminated by backdoor attacks,

Wu et al. [147] proposed a model reconstructing method of Adversarial Neuron Pruning. The core idea is to add perturbations to neurons and prune sensitive neurons to eliminate backdoor attacks. This method can reshape the model based on a small amount of clean data, and has wide applications in resisting backdoor attacks.

**Reliable model framework:** Zhou et al. [148] built a training framework upon the concept of split learning, designed to prevent backdoor attacks on semantic symbols by ensuring secure data transmission between the sender and receiver. Its U-shaped structure facilitates bidirectional data transmission: forward propagation begins at the sender, continues through a wireless channel to the receiver, where an activation signal is generated at the  $(k + m)$ th layer and returned to the sender. The sender then uses this signal to complete forward propagation and compute gradients, which are ultimately sent back to the receiver to update the model parameters. The purpose of this framework is to prevent backdoor attackers from injecting triggers into training data to implant backdoors within the model. By assuming an ideal channel, this framework effectively reduces the risk of data tampering during transmission, thereby preventing backdoor attacks and safeguarding the security and integrity of the SemCom system.

**Lesson 3.** *Backdoor attacks on DL models are primarily carried out by contaminating training data with malicious samples or altering the model structure, resulting in abnormal sensitivity to specific triggers. Extending this to SemCom, attackers can embed triggers to manipulate the semantics of transmitted symbols. To counter these attacks, researchers have proposed various defense methods targeting different stages of the model from the data and model levels. The data processing techniques can be achieved during training [132, 133, 134, 135, 136, 137, 138] and inference stages [139, 140, 141, 142]. The model identification and construction techniques include identifying poisoning models [143, 144, 145], pruning [146, 147], and reliable model framework [148],*

#### 4.4. Adversarial Training

To resist adversarial attacks, adversarial training is favored by researchers for its remarkable performance. As illustrated in Fig. 11, adversarial training is realized by adding adversarial attacks to the training samples. In SemCom, semantic adversarial samples are generated by adding noise to the semantic information to train the model together with the semantic information in the original training set.



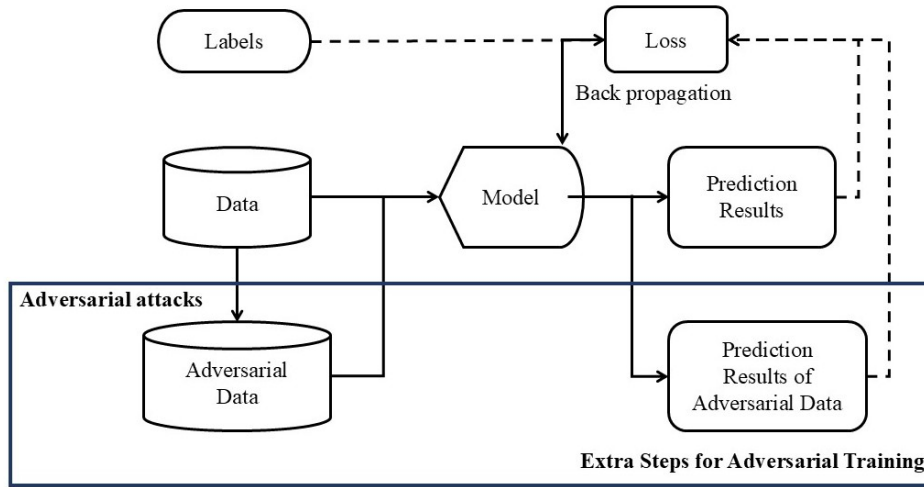

Figure 11: Process of adversarial training [149].

#### 4.4.1. Adversarial Sample Generation

Since the introduction of adversarial examples by Szegedy and Goodfellow et al.’s demonstration [150] that the high-dimensional linearity of neural networks is a fundamental cause of their vulnerability to adversarial attacks, a series of adversarial example generation methods have emerged. These methods are generally characterized by low computational cost and effective performance. The typical process for generating adversarial examples follows a series of key procedures. First, a network classifier is trained using normal data. Next, perturbations are introduced into the original samples to create adversarial examples. These perturbed samples are then input into the classifier, and the resulting classification error is computed. Subsequently, adversarial training is conducted to assess the classifier’s robustness against adversarial examples. Finally, the classification process is repeated to further refine the model’s resilience.

**Iterative fast gradient symbol method:** Hu et al. [151] presents a robust framework for developing end-to-end SemCom systems that can effectively withstand semantic noise. The approach utilizes an iterative Fast Gradient Symbol Method to dynamically generate semantic noise, allowing for realistic modeling of noise during training. To address this challenge, a novel weighted perturbation adversarial training method is introduced, which incorporates noise-affected samples into the training dataset. This method

solves a complex optimization problem, enhancing the model’s ability to resist semantic noise. By integrating these techniques, the proposed framework significantly improves the model’s robustness, making it more reliable in real-world communication environments.

**Semantic distance minimization mechanism:** As shown in Fig. 12, Kang et al. [152] proposes a defense strategy called the Semantic Distance Minimization mechanism to enhance the resilience of SemCom systems against adversarial attacks. The proposed method incorporates adversarial samples during training, enabling the model to learn how to counteract carefully crafted perturbations. The generation of these adversarial samples is based on maximizing the semantic distance from the original data, achieved by adding imperceptible semantic noise to the original samples. The proposed method employs Kullback-Leibler divergence to measure the semantic distance between the original and adversarial samples and optimizes model performance through a loss function that combines natural and robust losses. This approach increases the model’s robustness to adversarial samples while preserving accuracy on normal data. By dynamically generating and handling adversarial samples during training, the proposed method ensures stable performance across varying SNR conditions, effectively improving the security and reliability of SemCom systems in the face of adversarial attacks.

**Hybrid adversarial training strategy:** Nan et al. [153] introduce MobileSC, an innovative SemCom framework designed to optimize both computational and memory efficiency in wireless environments. Building on this framework, we propose SemAdv, a novel adversarial perturbation generator operating at the physical layer to produce adversarial samples. SemAdv is implemented via a multilayer perceptron neural network, which is specifically designed to generate semantically-oriented, imperceptible, input-agnostic, and controllable adversarial perturbations. These perturbations are aimed at misleading the interpretation of a specific semantic target without disturbing other semantic elements, all while not requiring prior knowledge of the input data during an attack. The proposed method seeks to create semantic adversaries that align with these criteria, offering a powerful tool for testing and improving the robustness of SemCom systems. Also, it proposes a the SemMixed training method, an innovative hybrid adversarial training strategy that integrates SemAdv and perturbation generator model techniques to generate both semantically-oriented and content-oriented adversarial samples. This approach enables the model to simultaneously address the challenges posed by different attack types. During each training

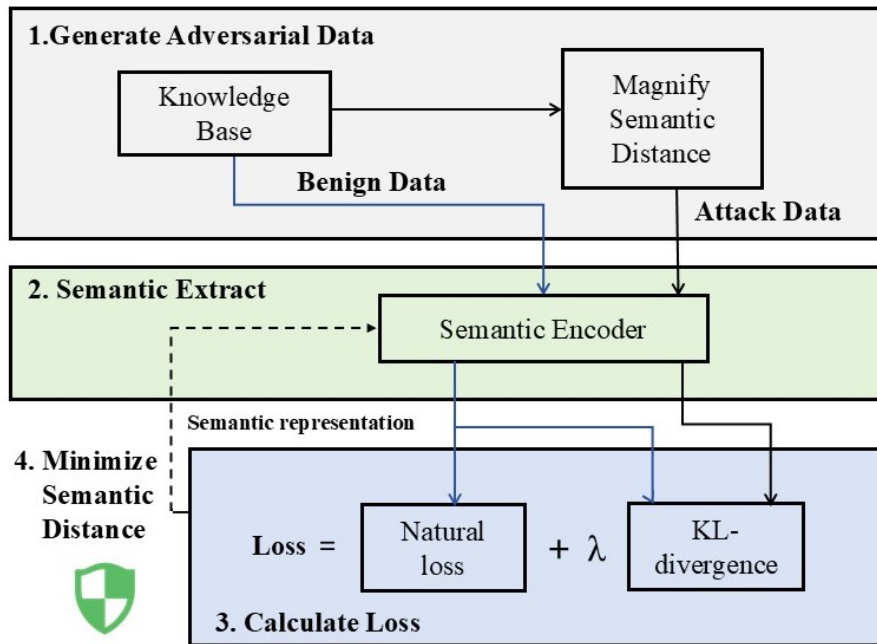

Figure 12: Semantic distance minimization mechanism [152].

stage, the system randomly decides whether to introduce adversarial samples and from which sources, thereby enhancing the model’s resilience to unknown attacks. Additionally, SemMixed combines clean and adversarial training to maintain the model’s accuracy while actively seeking out and defending against perturbations that could degrade performance. This is achieved through the optimization of a worst-case loss function, which further strengthens the model’s robustness against a wide range of potential adversarial threats.

#### 4.4.2. Model Optimization

Adversarial training enhances a model’s resilience by teaching it to identify both regular data and adversarial samples—intentionally crafted inputs meant to deceive the model. By iteratively improving its ability to counter these attacks, the model gains robustness against real-world noise and malicious interference. This process requires balancing performance on standard and adversarial data while refining the model’s decision boundaries to bol-

ster generalization and defense. The discussion focuses on three common approaches including adding adversarial regularization, using adaptive disturbance constraint and matching pluggable modules.

**Adding adversarial regularization:** Adversarial regularization involves adding terms to the loss function, including class consistency, semantic consistency, or distribution consistency between normal and classified adversarial samples, to improve the robustness of adversarial training.

- Combination adversarial training and encryption. Luo et al. [154] proposes an adversarial training-based Encrypted SemCom System designed to protect privacy while enabling secure SemCom. To ensure the accuracy of SemCom in both encrypted and un-encrypted modes, distinct loss functions are defined for each mode, and the transmitter, receiver, and attacker are trained simultaneously using adversarial training. In this setup, a regularization term, controlled by the hyperparameters, balance the performance of the decryptor and the effectiveness of the attacker’s efforts. Specifically, the loss function combines two components: LKd, the loss for the decryptor, and LA, the loss for the attacker. The training process consists of two main stages: first, training the channel coder and decoder, and then alternating the training of the attacker and the transmitter/receiver. This sequential training approach effectively mitigates the risk of the attacker eavesdropping on semantic information, enhancing the security of the communication system.
- Application for task-oriented SemCom. Wang et al. [155] introduces a novel defense algorithm, Misclassification Aware Adversarial Training, which applies adversarial regularization. The key idea behind MART is to distinguish between correctly and incorrectly classified samples during adversarial training and to apply distinct handling strategies for each. MART redefines adversarial risk by incorporating incorrectly classified samples as a regularization term, thereby encouraging the neural network to remain stable against adversarial examples derived from misclassified samples. This regularization enhances the model’s robustness to these misclassified samples. MART formulates adversarial training as a min-max optimization problem, where adversarial samples are generated by maximizing the internal loss, while the model is trained by minimizing the external loss to improve robustness. Ad-

ditionally, MART proposes a semi-supervised extension that leverages unlabeled data to further bolster robustness.

- Trade off between the accuracy and robustness. Zhang et al. [156] proposes Tradeoff-inspired Adversarial Defense via Surrogate-loss minimization, a defense strategy designed to enhance the adversarial robustness of DL models. The core idea behind TRADES is to incorporate a regularization term during training that balances the model’s accuracy on natural samples with its robustness against adversarial examples. TRADES is grounded in a theoretical framework that decomposes robust error into two components: natural error and boundary error. The optimization goal of TRADES is to minimize a loss function composed of two terms: one that reduces natural error by improving performance on clean data, and another that mitigates boundary error by increasing the distance between the decision boundary and both natural and adversarial samples, thereby enhancing robustness. The TRADES algorithm is implemented through alternating gradient descent and gradient ascent to approximate the minimax optimization problem. Specifically, adversarial samples are generated by adding small perturbations, and model parameters are updated by minimizing the combined loss of natural and boundary errors.

**Adversarial training with adaptive disturbance constraint:** Parameter configuration is crucial to enhance the robustness of the model. In most cases, the parameters of the attack including the number of iterations  $K$ , the attack step size  $\alpha$  with the perturbation constraint  $\varepsilon$ , which are artificially predefined during training. However, some researchers argue that individual data points may have different intrinsic robustness, which means they have different distances to the decision boundary of the classifier. If a fixed perturbation tolerance is imposed on all samples at the decision boundary, samples close to the decision boundary will be misclassified when the perturbation value is relatively large. The model is forced to adjust the decision boundary in order to adapt to these perturbed samples, resulting in a distortion of the decision surface of the entire model, which affects the model’s classification performance for other samples, especially samples far from the decision boundary. However, traditional adversarial training uses a uniform treatment for all samples. To address this problem, a series of adaptive methods can be used when setting such parameters, which can better improve the model robustness.

- **Max-margin adversarial training.** Ding et al. [157] proposed a Max-Margin Adversarial training method, the core idea of which is to adaptively choose a “correct” perturbation  $\varepsilon$  for each sample instead of using a fixed  $\varepsilon$ . The proposed method separates correctly categorized samples from misclassified samples. correctly categorized samples and misclassified samples separately. For correctly classified samples, the algorithm aims to directly maximize the margins in the input space by optimizing the objective function. Specifically, for each data point, Max-Margin Adversarial training finds the optimal  $\varepsilon$  value that maximizes its margin. For misclassified samples, the goal of this training is to minimize the classification loss of these samples. With this differential treatment, the proposed training not only improves the robustness of the model for correctly classified samples, but also improves the accuracy for misclassified samples.
- **Application for task-oriented SemCom.** Based on the training labels, Cheng et al. [158] proposed a new algorithm called Customized Adversarial Training (CAT) to improve the traditional training approach, which achieves this target of adaptively customizing the perturbation level for each training sample. The CAT algorithm updates the perturbations by iterative way to update the perturbations, keeping the current  $\varepsilon$  if a perturbation that makes the classifier’s prediction wrong is found, while, on the other hand, increasing  $\varepsilon$ . Meanwhile, the CAT algorithm proposes an algorithm for adaptive label smoothing, which correlates the smoothing parameter with the level of perturbations and helps the model to learn smoother decision boundaries. This ensures that the samples are not under the control of absolute one-hot coding under adversarial attacks. In the absence of adversarial perturbations, the output of the model approaches a more reasonable probability distribution of [0.5,0.5] as the samples approach the decision boundary.

**Matching pluggable modules:** Pluggable modules provide significant advantages for secure SemCom systems, enhancing security while preserving both efficiency and flexibility. Due to their high compatibility with existing architectures, these modules enable seamless integration without requiring modifications to the existing system structure. He et al. [159] investigate the advantages of secure-aware SemCom systems in countering adversarial attacks. They proposes installing a matched pair of pluggable modules—one positioned after the semantic transmitter and another before the semantic

receiver. The transmitter module employs a trainable Adversarial Residual Network to generate adversarial examples, while the receiver module uses a corresponding trainable network to mitigate adversarial attacks and channel noise. To counter semantic eavesdropping, these trainable network are jointly optimized to minimize a weighted sum of the adversarial attack’s strength, mean squared error in SemCom, and the eavesdropper’s confidence in accurately retrieving private information. Numerical results demonstrate that this approach effectively misleads eavesdroppers while preserving high-quality SemCom.

**Lesson 4.** *Adversarial training, which involves adding adversarial attacks to training samples, is favored by researchers for enhancing the robustness of models in SemCom by enabling them to recognize semantic adversarial samples generated through noise addition. Adversarial training approaches can be divided into adversarial sample generation and model optimization. The former includes iterative fast gradient symbol method [151], semantic distance minimization mechanism [152], and hybrid adversarial training strategy [153]. The latter includes adding adversarial regularization [154, 155, 156], adversarial training with adaptive disturbance constraint [157, 158], and matching pluggable modules [159].*

#### 4.5. Differential Privacy

Differential privacy is a new definition of privacy proposed by Dwork [160] in 2006 in response to privacy breaches in statistical databases. As shown in Fig. 13, under this definition, the result of computational processing of a dataset is insensitive to a specific data change, which means that the presence or absence of a single piece of data in the dataset has a negligible effect on the computational result. Extend to SemCom, the single semantic symbol cannot influence the meaning of the whole sentence. Therefore, the risk of privacy breaches arising from the addition of a piece of semantic symbol to a dataset is kept so small that an attacker cannot obtain accurate information by observing the results of the computation.

Assume two of semantic symbol sets are adjacent if they differ in a single entry. Then a randomized mechanism  $\mathcal{M} : \mathcal{D}_C \rightarrow \mathcal{R}$  with domain  $\mathcal{D}_C$  and range  $\mathcal{R}$ , satisfies  $(\epsilon, \delta)$ -differential privacy if for any two adjacent inputs  $d_C$  and  $d'_C$ , and for any subset of outputs  $S_C \subseteq \mathcal{R}$ , it holds that

$$Pr[\mathcal{M}(d_C) \in S_C] \leq Pr[e^\epsilon \mathcal{M}(d'_C) \in S_C] + \delta \quad (4)$$

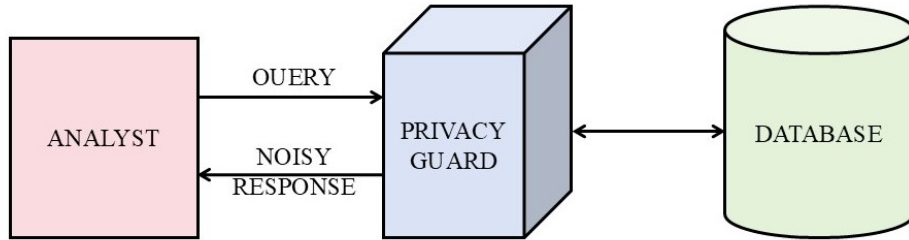

Figure 13: Differential privacy mechanism [161].

where  $\delta$  denotes the probability of  $\epsilon$ -differential privacy being broken.

Prior to its development, existing privacy-preserving algorithms, such as  $k$ -anonymity, had significant limitations against homogenization attacks. Differential privacy is able to address two shortcomings of traditional privacy-preserving models. First, the differential privacy-preserving model assumes that the attacker has access to semantic information about all other records except the target record, and the sum of this information can be understood as the maximum background semantic knowledge that the attacker can have. Under this semantic knowledge base assumption, differential privacy preservation does not need to consider any possible background knowledge possessed by the attacker. Second, it is built on a solid mathematical foundation that provides a rigorous definition of privacy protection and a quantitative evaluation method, which makes the level of privacy protection provided by datasets under different parameter treatments comparable.

Privacy-preserving ML requires the learner to be able to get hold of information about the distribution of data in a private dataset, while not revealing too much information about any individual in the dataset. Differential privacy can fulfill the above requirements well. Also differential privacy is a promising confidentiality technique in SemCom. Therefore, the use of differential privacy in the model training phase would be analyzed in the following three aspects: parameter values, objective function and data, which are illustrated in Fig. 14.

#### 4.5.1. Parameter Value Protection

To protect the privacy of the training data, it is possible to focus on the final parameters produced by the training process without focusing on the



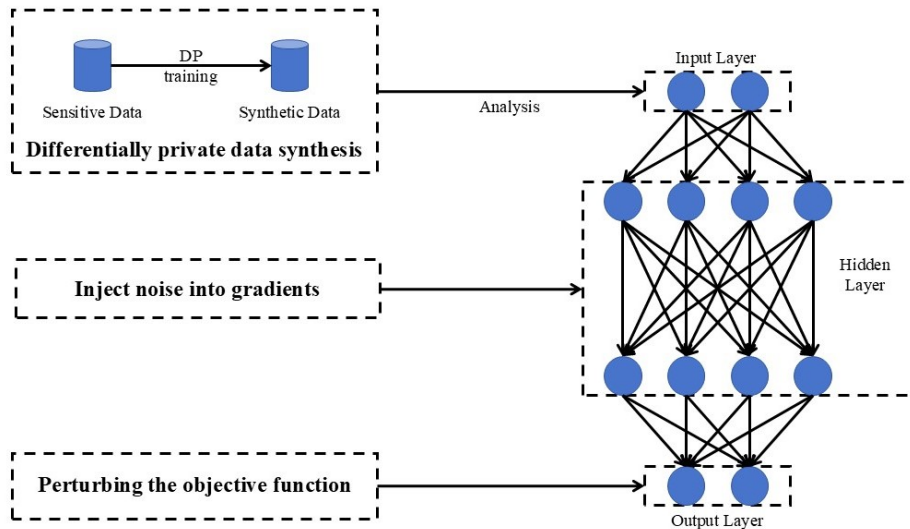

Figure 14: The three phase of differential privacy deployed in deep learning model [162].

specific internal operations, considering the process as a black box. However, the correlation between these parameters and the input data is difficult to measure by a specific and reliable standard. The operation of adding noise to the parameters is conservative, which cannot guarantee the security of the learning model reliably. Therefore, the model is assumed to be vulnerable to malicious attacks on the parameters, assuming that the adversary fully understands the training mechanism and has access to the model's parameters. Based on the above problems, an effective method is to use differential privacy to protect the model parameters uploaded by the client. Model parameters are mainly divided into two types: model weight and gradient.

**Weight of Model:** In AI-enabled networks, differential privacy is widely applied to FL. In FL, a client, including a cell phone or edge device, trains a model based on its local data and uploads updated model weights to a central server. These parameters may leak the client's data characteristics and thus need to be noised to protect privacy. Differential privacy enables the model updates without the risk of leaking too much information about any individual data point in the training data set [163]. For instance, Wei et al. [164] added random Gaussian noise at the aggregated global model to hide any single client's update in the centralized pattern. Specifically, Kang Wei et al. propose a new framework based on the DP concept, Noising before Aggregation FL, to effectively prevent information leakage. Each client locally

perturbs its training parameters by purposefully adding noise to ensure that the uploaded parameters satisfy a specific level of privacy protection and uploads the updated model weights to the central server before uploading its training parameters to the server for aggregation. The system achieves an effective balance between privacy protection and model performance by sharing key parameters of the model to improve learning accuracy while protecting the privacy of participants' data. In SemCom systems, the sender can add the noise to the model update before model-sharing, which is helpful for privacy-preserving, especially in multi-hop scenarios. Several researchers [164, 85, 165, 166] have demonstrated that the obfuscated parameters in differential privacy lead to a trade-off between the model training-accuracy and security. Therefore, adding well-designed differential privacy and the proper way to add noise matters to the model-driven networks, especially in the multi-hop manners.

**Gradient of Model:** The gradient leakage data attack can reconstruct the local data through the shared gradients of the participants, which brings a new challenge to the privacy preservation problem of the learning model. To better address the model security issue, differential privacy is introduced in optimization algorithms for gradient. Specifically, noise is injected into the gradient of the client parameters before the training results are sent to the server. Differential privacy ensures that no information about any individual training sample can be accurately inferred even when the model parameters are made public. A prime example of this is the selective sharing of model parameters during model training by Shokri et al. [163]. The parameter selection rate determines the number of parameters updated in iterations for each parameter subset. During the parameter subset selection process, the gradients whose median values are larger than a specific threshold are randomly selected for uploading, and this approach is similar to the idea of differential privacy. Also, to further protect privacy, differential privacy techniques are used through the Lapp system to ensure that parameter updates do not reveal too much information about individual points in the training data. This is accomplished through sparse vector techniques and a Laplacian mechanism that adds noise to selected gradients and controls the privacy budget. Song et al. [167] introduced differential privacy in Stochastic gradient descent. They theoretically derived the gradient descent with differentially private algorithm and verified the feasibility of the algorithm. Abadi et al. [168] developed the algorithm on this basis and proposed the differentially private stochastic gradient descent algorithm (DP-SGD) algorithm, which is

reflected in the proposal of an effective algorithm for calculating the single training examples' gradient, the efficient algorithm for subdividing the task into smaller batches to reduce memory footprint, and the application of the differentially private principal projection at the input layer. Specifically, the algorithm adds Gaussian noise to the gradient to preserve privacy, where the size of the noise is proportional to the sensitivity of the gradient. It controls the impact of each training sample on the model update by limiting the l2 norm of the gradient through Norm clipping, and uses the "Moments Accountant algorithm to compute the overall privacy loss during the training process to measure whether a set level of privacy protection is met. Liu et al. [169] introduces the Adaptive Privacy Budget-based Differential Privacy (APB-DP) method. APB-DP leverages differential privacy (DP) with an adaptive privacy budget, adjusting noise levels as models converge to ensure consistent privacy protection throughout training. Additionally, APB-DP accounts for wireless channel effects to reduce interference. Experimental results demonstrate that APB-DP decreases privacy leakage by 13 percent and minimizes performance loss by 71 percent compared to leading DP-based training methods, providing a more secure and efficient solution for SemCom.

#### 4.5.2. Objective Function Perturbation

Differential privacy is one of the methods of target perturbation, which plays a crucial role in model training. The application of differential privacy in objective perturbation is mainly reflected in the design of privacy-preserving algorithms for security frameworks. Specifically, the objective perturbation approach adds random noise to the objective function by using differential privacy in the optimization process instead of injecting noise directly into the result. This approach puts privacy preservation into consideration in algorithm design. The optimization process is interfered by adding noise to the objective function to improve robustness, thereby protecting the privacy of individuals in the training data process.

**Classifier optimization:** Chaudhuri et al. [170] designed an empirical risk minimization framework that uses differential privacy to perturb the objective function, which is the combination of the loss function and the regularization term, and then optimizes the classifier based on this situation. Compared to the direct perturbation of the output result, perturbation of the objective function reduces the prediction error under the condition of preserving privacy. It achieves the goal that balances the trade-off between privacy preservation and learning performance.

**Linear and logistic regression analyzation:** Zhang et al. [171] proposed a concept of Functional Mechanism to describe the operation of perturbing the optimization goal function of regression analysis. The noise is injected into the objective function using differential privacy on the two most commonly used regression models, linear regression and logistic regression. Regularization and spectral pruning techniques are used to ensure the objective function to get a meaningful solution. Experimental results show that the accuracy of functional mechanism differential privacy in linear regression and logistic regression tasks significantly outperforms existing differential privacy preservation methods, including Filter-Priority and so on. In particular, the accuracy advantage of FM is more obvious when the data dimension increases. Meanwhile, the low-order approximation module of FM makes its computational efficiency much higher than that of ordinary baseline methods.

**Combination with Auto-Encoder:** Phan et al. [172] propose a Deep Private Auto-Encoder model, achieving  $\epsilon$  differential privacy preservation by introducing perturbations into the objective function traditional deep self-encoder. To make the objective function satisfy differential privacy, this paper approximates the cross-entropy error functions of the data reconstruction and softmax layers into polynomial forms using Taylor Expansion, and injects noise into these polynomial forms. The auto-encoder preserves most of the valid information of the input data by minimizing the reconstruction error between the input and the output results through an objective function. The autoencoder learns the important features of the input data to hide the sensitive information of the input data in the output data, which achieves accurate prediction of human behavior.

**Adaptive laplace mechanism:** The article as we mentioned before adds the same amount of noise in the model, which shows great limitations in the application of different application scenarios. To solve this problems, Phan et al. [173] also proposed a new mechanism of Adaptive Laplace Mechanism. It utilizes the Layer-wise Relevance Propagation algorithm to calculates the relevance between the input features and output feature of the model. The Adaptive Laplace Mechanism adds more noise into features that have less influence on the model output while adding less noise in significant feature. This scheme promotes the wide application of differential privacy techniques in DL.

### 4.5.3. Data Generation and Pre-processing

In terms of data generation, differential privacy is applied to protect data privacy in the generative model of the input layer, which can be regarded as a pre-processing of the training dataset. The data manager first generates synthetic data with the same statistical features as the original training dataset under differential privacy. The synthetic data and generated models are then released without compromising privacy, which can be used for a variety of analyses.

**Generative model:** Acs et al. [174] introduce differential privacy techniques during the training process of generated models to protect the privacy of the individual data used to train these models. Specifically, the dataset is divided into  $k$  clusters using differential privacy and  $k$ -mean clustering algorithms. A generative neural network is assigned to each cluster and cluster is trained by differential privacy gradient descent respectively. To solve the problem of complex data privacy protection, Zhang et al. [175] proposed to propose dp-GAN, a generalized private publishing framework for rich semantic data, in which the differential privacy mechanism is integrated based on the existing GAN models. The random noise is injected into the training step of discriminator to perform differential privacy constraints. Various optimization strategies, such as Parameter Grouping, Adaptive Clipping and Warm Starting, are used to generate high-quality synthetic data. Chen et al. [176] introduces a novel approach to secure SemCom by combining differential privacy (DP) with a GAN-based inversion technique to protect sensitive image data transmitted over insecure channels. By extracting and safeguarding essential semantic features, the proposed method reduces privacy risks while enabling accurate data reconstruction at the intended receiver. Simulation results confirm that this approach effectively prevents eavesdroppers from accessing sensitive information while preserving high-quality image reconstruction, highlighting its potential as a robust solution for privacy-preserving SemCom.

**Adding noise in tree structure:** Cormode et al. [177] proposed a framework called Private Spatial Decompositions, which utilizes the Laplace mechanism to add noise to each node in the dataset on a tree structure. Non-uniform assignment of noise parameters to data nodes ensures that both the tree structure and node counts satisfy differential privacy.

**Dynamic dataset publishing:** Li et al. [178] focus on differential privacy in dynamic dataset publishing. Two methods, distance-based sampling

with fixed threshold and distance-based sampling with adaptive threshold, are proposed for handling the dynamics of dynamic datasets under user-level differential privacy. Specifically, the fixed threshold method uses a fixed threshold to publish a new differential privacy histogram only when the distance between the current dataset and the previously published dataset exceeds a predefined threshold. While the adaptive threshold method further improves fixed threshold by dynamically adapting the threshold using a feedback control mechanism to capture data dynamics.

**Lesson 5.** *In differential privacy, user privacy in published semantic datasets is protected by introducing random noise. Noise-attachment mechanism is a method of protecting data by perturbing it through a predefined mechanism. The addition of noise makes it possible to add or remove any record from the input data without significantly affecting the output of the algorithm. This approach ensures that even if an attacker has some information, he or she cannot reliably infer sensitive information. Differential privacy is realized from the following perspectives: parameters (model weights [164, 164, 85] and gradients [163, 167, 168, 169]), objective functions [170, 171, 173], and data [174, 175, 177, 178]. Generative models [172, 174, 175, 176] are generally combined to protect differential privacy.*

#### 4.6. Cryptography Technology

In traditional communication systems, encryption technologies ensure data confidentiality during transmission by converting plaintext into randomized ciphertext. Methods such as AES and RSA rely on complex mathematical algorithms, making it difficult for unauthorized users to decrypt data. However, with the evolving demands of communication, particularly in SemCom, the limitations of traditional encryption methods have become increasingly apparent.

SemCom significantly enhances communication efficiency by extracting and transmitting semantic features. However, the randomized ciphertext generated by traditional encryption methods makes it difficult to extract semantic information and disrupts the semantic correlation of the data. Moreover, the “avalanche effect” of traditional encryption and its limited ability to directly operate on ciphertext further constrain its applicability in SemCom. Against this backdrop, innovative encryption technologies such as Homomorphic Encryption (HE), Secure Multi-Party Computation (SMPC), Trusted

Execution Environment (TEE), and secure aggregation have garnered significant attention.

These emerging encryption technologies offer a balance between data protection and semantic processing. For instance, SMPC enables collaborative data computation without compromising privacy; HE allows addition and multiplication directly on ciphertext, facilitating complex data processing without decryption; TEE ensures secure execution of sensitive data through hardware-level isolation; and Secure Aggregation provides an efficient mechanism for data merging in distributed SemCom. The integration of these technologies not only addresses the shortcomings of traditional encryption but also presents novel solutions for enhancing the efficiency and security of SemCom systems. These new technologies are described below.

#### *4.6.1. Homomorphic Encryption*

HE is an advanced cryptographic technique that allows mathematical operations to be performed directly on encrypted data without decryption. This characteristic is particularly valuable in privacy-preserving scenarios, where computations need to be performed without exposing the underlying data. The core concept of HE ensures that operations performed on ciphertext yield results that, when decrypted, match those obtained if the same operations were applied to the plaintext. This innovative feature has opened up new research areas, especially in cloud computing, FL, and privacy-preserving ML applications.

HE can be categorized into two types: Partially Homomorphic Encryption (PHE) and Fully Homomorphic Encryption (FHE). PHE supports a single type of operation, such as multiplication in RSA or addition in Paillier, while FHE supports both addition and multiplication operations an unlimited number of times, making it the most powerful encryption scheme in theory. In 2009, Craig Gentry [179] introduced the first practical FHE scheme based on ideal lattices, providing a groundbreaking tool for privacy preservation in academia and industry.

Despite its strong privacy-preserving capabilities, the significant computational and communication overhead associated with HE remains a major challenge for its adoption in real-world applications. In recent years, researchers have focused on optimizing encryption algorithms to improve efficiency and reduce the computational cost of ciphertext operations. Below, we discuss some typical applications and optimization methods of HE in the field of DL.

**PHE:** Phong et al. [180] proposed a privacy-preserving DL framework using additive HE. By leveraging the asynchronous stochastic gradient descent algorithm and encrypting gradients with the Paillier system, the framework mitigates potential data leakage risks in cloud-based servers. Experiments showed that this approach achieved near 99% accuracy on the MNIST dataset while effectively preventing data leakage between participants. This research highlights the potential of additive HE in achieving a balance between privacy and performance in distributed learning environments. In FL, Fang et al. [181] introduced a framework combining additive HE and FL, which is shown in Fig. 15. This framework incorporates an optimized Paillier algorithm, significantly reducing encryption computation time while maintaining model accuracy deviations within 1%. It is particularly well-suited for applications requiring high privacy standards, such as finance and healthcare. Their experiments further analyzed the impact of key length, network structure, and the number of clients on system performance, providing insights into balancing privacy and efficiency in complex environments.

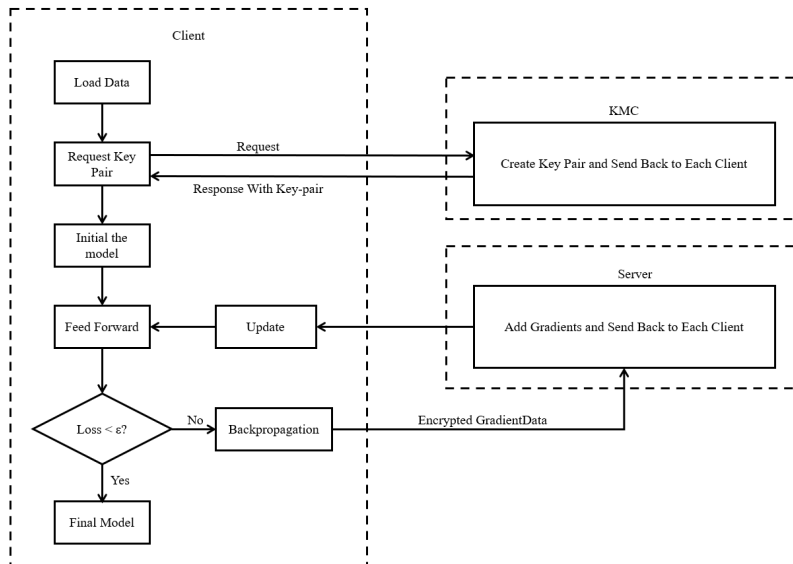

Figure 15: The architecture of a Paillier federated network [181].

**FHE:** Lee et al. [182] developed a DL inference model using FHE. Their research employed the CKKS scheme with bootstrapping technology



to implement encrypted inference on the ResNet-20 model for the CIFAR-10 dataset, achieving an accuracy of 92.43%, nearly matching the plaintext model’s 91.89%. To address challenges in non-linear activation functions within encrypted environments, they utilized high-precision polynomial approximations as substitutes and, for the first time, implemented Softmax encryption within the FHE framework to defend against model extraction attacks. This study underscores the practicality of FHE in privacy-preserving DL and efficient inference. Additionally, Sun et al. [183] proposed an improved FHE scheme. Their work focused on enhancing computational efficiency and reducing noise accumulation through relinearization and modulus switching techniques. This scheme achieved significant efficiency improvements in private decision tree classification and other tasks like Naïve Bayes classification. Experimental results demonstrated its effectiveness, achieving high-performance homomorphic computations across multiple ML classification tasks.

**Efficient frameworks and optimized solutions:** To address cross-silo FL requirements, Zhang et al. [184] introduced the BatchCrypt system. The system employs a batch encryption method to compress gradient data, significantly reducing encryption computation and communication overhead. Experiments validated that BatchCrypt enhanced training speed by 23–93 times and reduced communication costs by 66–101 times compared to traditional methods, all while maintaining model accuracy. This system provides an efficient and secure encryption framework for cross-organizational data collaboration.

#### 4.6.2. *Secure Multi-Party Computation*

SMPC serves as a core tool for privacy-preserving technologies, allowing multiple parties to jointly compute specific functions without revealing their private input data. It effectively resolves the conflict between data privacy and collaboration requirements. With the increasing reliance on distributed data in ML, SMPC provides robust privacy guarantees for secure model training and inference, striking a balance between data sensitivity and collaboration efficiency. Fig. 16 illustrates a conceptual diagram of SMPC.

The core of SMPC lies in utilizing cryptographic techniques to ensure the privacy, correctness, robustness, and fairness of distributed computations. Key techniques include secret sharing, HE, and oblivious transfer. Secret sharing divides private data into multiple fragments distributed among the participants, ensuring that no single fragment reveals any meaningful infor-

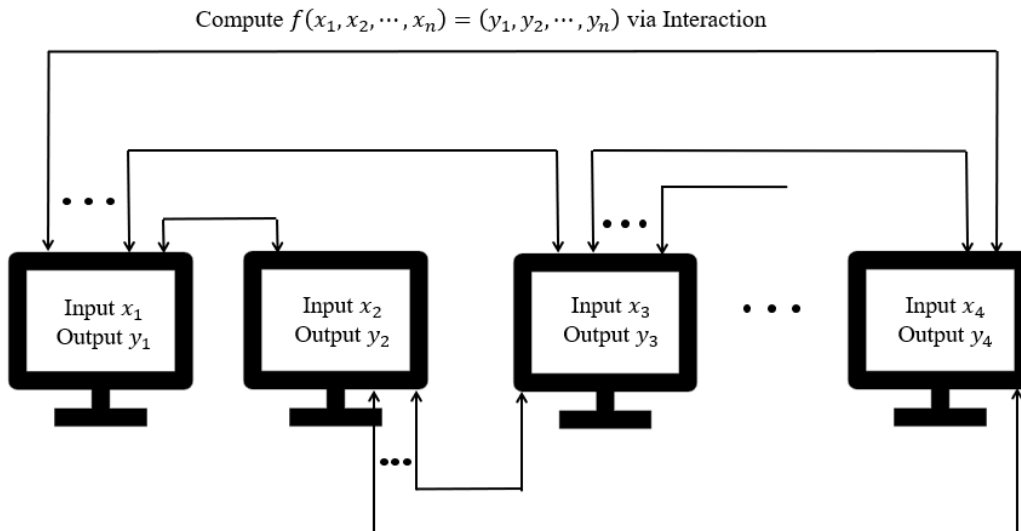

Figure 16: The diagram of SMPC [185].

mation [185]. HE allows computations to be performed directly on encrypted data, protecting data privacy without requiring decryption during intermediate steps.

In SMPC security models, the semi-honest model assumes participants strictly follow the protocol but may try to infer additional information, while the malicious model allows participants to arbitrarily deviate from the protocol [185]. Foundational research by Yao and Goldreich [186] laid the theoretical groundwork for two-party and multi-party computations, establishing the basis for modern SMPC development. In recent years, significant progress has been made in applying SMPC to ML, including advancements in asynchronous multi-party computation, the SPDZ framework, Falcon protocol, SecureNN, CRYPTEN framework, and applications in FL.

**General ML Frameworks:** These frameworks aim to provide secure, scalable, and efficient solutions for common ML algorithms, covering a wide range of tasks.

- **SPDZ Framework:** Proposed by Chen et al. [187], the SPDZ framework is a SMPC implementation that provides malicious security guarantees. It uses a preprocessing phase based on additive secret sharing to generate “Beaver triples”, significantly improving the efficiency of the online computation phase. The framework has been successfully applied to

linear regression and logistic regression and can securely execute iterative algorithms like stochastic gradient descent on large-scale datasets.

- **CRYPTEN Framework:** Developed by Knott et al. [188], CRYPTEN integrates SMPC with ML by providing an API similar to PyTorch. It supports tensor computation, automatic differentiation, and modular neural networks, simplifying the implementation of privacy-preserving ML models. This design is particularly suitable for researchers and practitioners unfamiliar with cryptographic techniques, driving the wide application of SMPC in ML.

**Protocols for Neural Network Training and Inference :** SMPC protocols designed for DL address the challenges of secure training and inference in complex neural networks. These methods emphasize performance optimization in linear transformations and nonlinear activation functions.

- **SecureNN Protocol:** Proposed by Wagh et al. [189], SecureNN extends SMPC capabilities to neural network training. It employs a three-party computation model, avoiding costly cryptographic circuit operations and optimizing secure protocols for matrix multiplication, convolution, and nonlinear functions. Experiments on the MNIST dataset demonstrated that this protocol achieves over 99% classification accuracy while significantly reducing communication complexity.
- **Falcon Protocol:** Developed by Wagh et al. [190], the Falcon protocol is an end-to-end SMPC framework specifically designed for DL models. It supports high-capacity architectures such as VGG16 and AlexNet, incorporating batch normalization to enhance training stability. By adopting efficient secret-sharing-based protocols for nonlinear operations like ReLU and MaxPool, Falcon achieves an 8x performance improvement compared to previous methods. This makes it a practical choice for DL tasks and opens new possibilities for efficiently handling complex neural networks.

**Scalability and Communication Efficiency:** Research in SMPC has focused on improving scalability and reducing communication costs, which are crucial for distributed ML. Damgård et al. [191] proposed an asynchronous multi-party computation protocol designed for large-scale distributed

computation. Combining Shamir’s secret sharing and preprocessing techniques, the protocol ensures security even when up to one-third of the participants are compromised. To enhance communication efficiency and scalability, they developed the Virtual Ideal Functionality Framework, which supports parallel secure multiplications. This demonstrates the practical potential of asynchronous protocols for large-scale data environments.

**Applications of SMPC in FL:** FL represents a key application area for SMPC, focusing on collaborative ML over distributed datasets while addressing privacy concerns. Mugunthan et al. [192] integrated SMPC into FL to address model parameter leakage. By employing cryptographic masking techniques to protect individual contributions and combining differential privacy with SMPC, they enhanced security during model updates. This framework is highly suitable for distributed application scenarios such as medical research, maintaining high computational accuracy while safeguarding data privacy.

#### *4.6.3. Trusted Execution Environment*

The TEE, as a hardware-level security technology, provides strong technical support for FL, showcasing significant advantages in areas such as privacy protection, secure model parameter aggregation, defense against malicious behavior, and side-channel attack prevention. TEE establishes trusted execution zones at the hardware level to ensure that sensitive information is not accessed or tampered with during operation. Below is an introduction to the mainstream TEE implementations in recent years and their applications in FL.

**Mainstream TEE Implementations:** Intel SGX [193] (Software Guard Extensions) utilizes ”Enclave” isolation for user-space execution, making it suitable for privacy-protecting distributed computing. Intel SGX, which is shown in Fig. 17, provides hardware-level protection for applications, ensuring that sensitive data can be processed securely even in untrusted environments. This technology is critical in FL for safeguarding data during training, preventing leakage or unauthorized access even on client devices. ARM TrustZone [194] separates hardware resources into “secure world” and “normal world” and is widely used in IoT and mobile devices. TrustZone ensures robust isolation and security, allowing only certified code to execute in the secure world, thereby protecting local data privacy. AMD’s SEV [193] focuses on cloud computing environments, providing memory isolation for virtual machines and enhancing security in virtualized cloud environ-

ments. Unlike Intel SGX, SEV targets cloud service providers, ensuring that inter-virtual machine memory data remains protected even against malicious administrators.

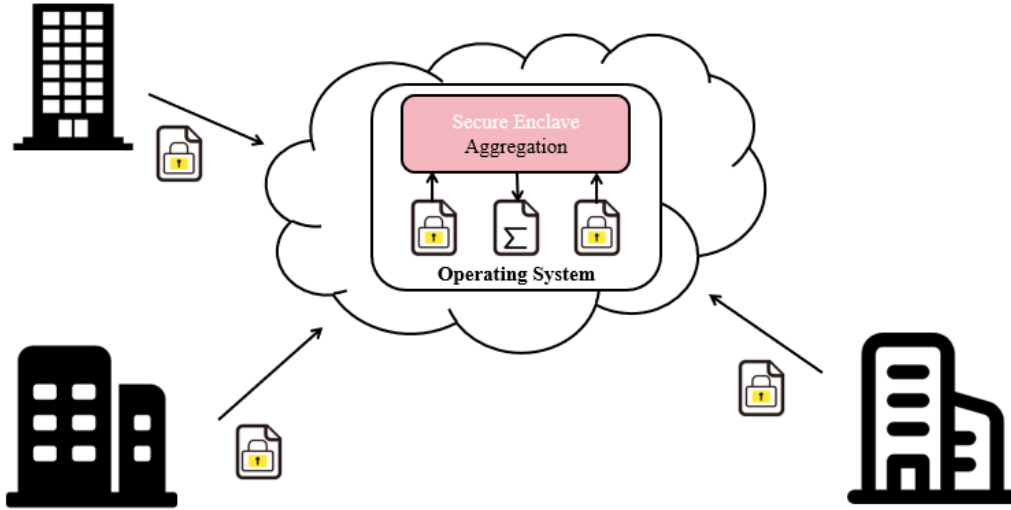

Figure 17: SGX Diagram [195].

**Applications in FL:** TEE ensures the privacy of training data on local devices. By executing training tasks within a client’s TEE, sensitive data remains in an isolated environment, preventing external access or leakage. For example, Fan et al. [196] introduced a TEE-based privacy protection mechanism in the PPFL framework, which significantly reduces the risks of data reconstruction and inference attacks by locally safeguarding client data and gradients. Additionally, Hamed Haddadi et al. [194] isolate the most sensitive layers of deep neural networks within TEE, effectively enhancing privacy protection. The global model aggregation process in FL is vulnerable to gradient inversion attacks. To address this issue, Yuhui Zhang et al. [195] proposed the ShuffleFL framework, which performs randomization and grouped aggregation within TEE to reduce the likelihood of attackers inferring original data from gradients. On the other hand, Aditya Pribadi Kalapaaking et al. [197] integrated blockchain technology to host model aggregation tasks within TEE, achieving tamper-proof and transparent model updates. Malicious clients in FL may attempt to degrade global model performance by uploading fabricated gradients or reusing outdated model updates. To counter this, Xiaoli Zhang et al. [124] developed the TrustFL framework,

utilizing TEE to randomly verify the integrity of client training tasks and ensure adherence to predefined procedures. Furthermore, Arup Mondal et al. [198] proposed FLATEE, which executes model updates in a distributed manner across multiple TEEs, significantly reducing the interference of malicious behavior on aggregation results. TEE can prevent side-channel attacks through hardware isolation and gradient obfuscation techniques. For instance, Yuhui Zhang et al.’s ShuffleFL framework [195] employs a random grouping strategy combined with secure processing within TEE to mitigate attacks through cache and timing analysis. Moreover, the PPFL framework [196] further reduces the risk of gradient leakage by protecting all layers of the model.

#### 4.6.4. Secure Aggregation

Secure aggregation is a computational technology designed to protect data privacy, widely applied in distributed ML scenarios such as FL. In these scenarios, multiple participants (e.g., mobile devices or distributed nodes) collaborate to train a global model while ensuring data privacy. By using encryption, masking, or other privacy-preserving mechanisms, participants share only encrypted or perturbed local model updates with the server. As a result, the server can only access the aggregated result without revealing the individual updates from participants. Below, we discuss significant advancements in secure aggregation through detailed explanations of representative papers.

**Techniques Addressing Participant Dynamics:** Liu et al. [199] proposed an innovative secure aggregation method that tackles the issue of device dropout. By leveraging a Homomorphic Pseudorandom Generator and Shamir’s secret sharing, they developed an efficient and dropout-resilient aggregation mechanism. Unlike traditional methods that rely on expensive cryptographic primitives such as Diffie-Hellman key exchange, their solution utilizes this method for pre-key generation, significantly reducing communication overhead. Shamir’s secret sharing ensures the system can recover global model updates even if some devices fail to participate, improving overall robustness. Experimental results demonstrated that this scheme outperformed existing methods by over six times in runtime efficiency, making it a practical choice for large-scale distributed systems. Kadhe et al. [200] designed a secure aggregation protocol based on the Fast Fourier Transform. As is shown in Fig. 18, this approach addresses the high computational complexity of traditional methods by introducing a multi-secret sharing mecha-

nism optimized for FL. The FFT-based design reduces computational costs for both servers and clients while maintaining the capability to handle a fixed proportion of device dropouts. FastSecAgg showed exceptional scalability and adaptability in dynamic environments, making it ideal for large-scale distributed systems. Bonawitz et al. introduced a practical protocol based on one-time masks. The scheme ensures that individual model updates remain private by exchanging random pairwise masks among clients. Even if some devices drop out, the protocol reconstructs the missing masks using pre-distributed secret shares, enabling the server to compute the aggregated result securely. This design is particularly suitable for FL scenarios involving mobile devices, demonstrating effectiveness in handling high-dimensional data under unstable network conditions.

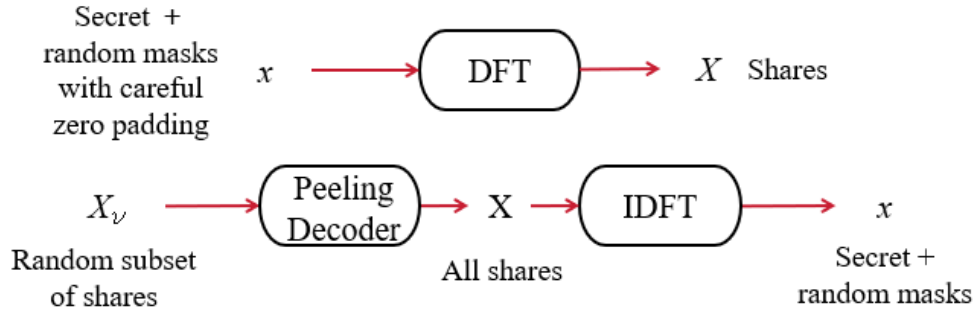

Figure 18: Schematic diagram of the algorithm based on the FFT [200].

**Communication-Efficient Secure Aggregation Methods:** Bonawitz et al. [201] explored methods to optimize communication costs in secure aggregation. They introduced a combination of random rotation and quantization techniques to compress model updates into smaller sizes while preserving essential information. Random rotation enhances privacy protection and significantly reduces communication overhead, making the method highly effective for transmitting high-dimensional model updates. Furthermore, the protocol employs adaptive tuning to adjust parameters dynamically, ensuring optimal performance across varying hardware configurations and network conditions. This approach effectively addresses the communication bottleneck in FL.

**Enhancing Privacy and Robustness:** Kairouz et al. [202] presented a novel mechanism that combines discrete Gaussian noise with differential privacy to enhance secure aggregation. By locally adding discrete Gaussian

noise to model updates, the approach ensures strong privacy guarantees while reducing the risk of data leakage. This mechanism is further integrated with secure aggregation techniques, allowing the server to access only the aggregated results. Their analysis quantified the trade-offs between communication efficiency, privacy protection, and model accuracy, offering an innovative solution for distributed learning systems that achieves near-centralized differential privacy performance at low communication costs. Zhao et al. [203] proposed a hardware-based solution using Intel SGX to protect privacy and defend against Byzantine adversaries. The framework employs sampling-based anomaly detection to identify and filter malicious participants' updates by analyzing specific model features. Intel SGX ensures data confidentiality through hardware isolation, even in adversarial environments. This framework is well-suited for high-risk scenarios where robust privacy protection and resilience against malicious attacks are critical.

**Lesson 6.** *In traditional communication systems, encryption technologies like AES and RSA ensure data confidentiality but limit semantic processing, posing challenges for SemCom. To address these challenges, emerging encryption technologies such as SMPC [187, 188, 189, 190, 191, 192], HE [180, 181, 182, 183, 184], TEE [193, 194, 193, 196, 194, 195], and secure aggregation [199, 200, 201, 202, 203] offer a balance between data protection and semantic processing, enhancing the efficiency and security of SemCom systems. Notably, PHE simplifies operations and is suitable for lightweight privacy-preserving scenarios, while FHE excels in supporting complex tasks with strong security guarantees. With ongoing advancements in algorithms and expanding applications, HE is set to play an increasingly vital role in privacy preservation and collaborative data computation in future SemCom.*

#### 4.7. Block-Chain Technology

As shown in Fig. 19, block-chain technology is an undeniable ledger technology that stores transactions in high-security chains of blocks [204]. In AI-enabled networks, block-chain technology has been widely applied to secure the model training in FL by sharing a shared transaction ledger without requiring a trusted third party [205, 206, 207, 208, 209, 210, 211]. As in [205, 208], each participant in SemCom system can attach the model during the model collaborative training process. After exchanging and verifying the received model updates, the miners compete to work on a block. The first miner who finishes the job records the generated block to the distributed



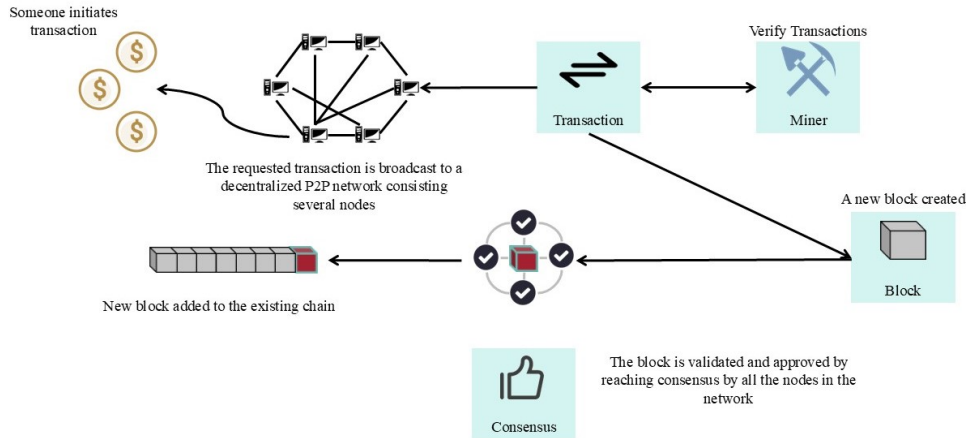

Figure 19: Functional diagram of a blockchain network. [212].

ledger. Then the participants download the block for the local model update for model co-training. In addition to the model update process, given that it is impossible to change a single block without being detected [205], the node in SemCom system checks the block header to ensure the immutability and integrity of the received model and model slice during the model transmission process. Blockchain also enables SemCom system with audibility and traceability when a suspicious event occurs. As in [207, 206], the clients' requests and the server's responses are recorded in an auditable manner. In such a way, the abnormal node can be found by evaluating the contribution of each node's model to the malicious event.

#### 4.7.1. Data Security

A lot of researches have been done to prove that intermediate gradients can reveal sensitive information about training data, highlighting the limitations of FL frameworks in fully protecting data privacy, especially in the presence of malicious attackers. Moreover, the issue of data leakage during distributed transmission further exacerbates privacy concerns. Blockchain technology, with its decentralized architecture, cryptographic techniques, consensus algorithms, and distributed storage capabilities, offers a promising solution. By leveraging its unique data structure and integrating it with complementary technologies, blockchain can enhance the security of data transmission and effectively mitigate data leakage risks, providing a more robust and reliable framework for FL systems.

**Privacy-Enhanced FL:** Preuveneers et al. [213] introduce Privacy-

Enhanced FL , an innovative framework that leverages blockchain technology to enhance data security and privacy in FL. By recording iterative updates to eliminate the need for centralized training data. This approach upholds the decentralized nature of model training and effectively preserves data privacy. The proposed framework consists of three key components: the Key Generation Center, the Central Server, and multiple participants. It also integrates post-quantum security measures to protect the privacy of the aggregator and secure the data, even in cases where attackers may collude with multiple entities. Additionally, the auditing mechanism within the proposed framework monitors and validates blockchain transactions, enabling the detection of tampering or fraudulent activities related to model updates. This comprehensive solution significantly strengthens the security and integrity of FL systems.

**Blockchain-based FL:** Liu et al. [214] presents a blockchain-based FL framework aimed at safeguarding data security and privacy in 5G networks. The framework mitigates contamination attacks by automatically verifying model updates through smart contracts. It also incorporates local differential privacy techniques to protect against membership inference attacks. Leveraging the transparency and immutability of blockchain, the framework ensures robust data security, offering an effective solution for securing FL in 5G environments.

**Blockchain for sharing semantic information:** Lin et al. [215] introduce an innovative framework that integrates blockchain and semantic ecosystems for sharing semantic information. The framework consists of four key components: semantic encoder, channel, semantic proof, and semantic decoder. To address the “garbage-in, garbage-out” problem, the authors propose a semantic consensus mechanism based on threshold signatures, ensuring that only accurate and relevant semantic information is added to the blockchain. Furthermore, a semantic sharing mechanism, utilizing state channels and task-related information bottleneck methods, effectively reduces information redundancy. By combining blockchain’s security and decentralization with the efficient information processing capabilities of SemCom, the framework optimizes network resource utilization while ensuring data security and trust.

**Optimize and maintain semantic knowledge base:** As illustrated in Fig. 20, Lin et al. [216] propose a blockchain and edge computing-assisted SemCom framework designed to optimize and maintain knowledge bases within the remote driving domain. The primary objective of the frame-

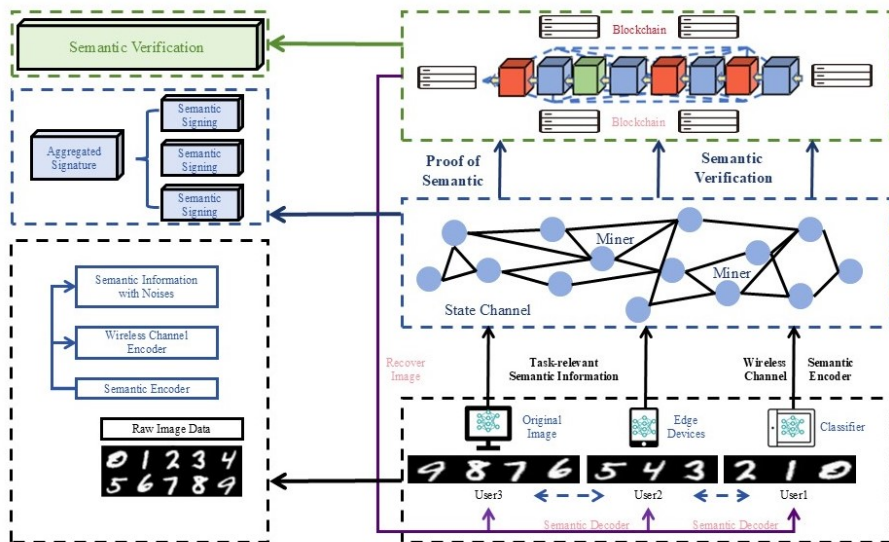

Figure 20: An illustrative framework of Blockchain-Semantic ecosystems [216].

work is to reduce communication costs by prioritizing the transmission of semantically meaningful information over simple bit-level data. The authors introduce a semantic segmentation strategy, leveraging geographically distributed edge nodes that can adapt to diverse contextual environments, enabling the integrated management of multiple knowledge bases. To ensure system security, the framework capitalizes on the tamper-proof characteristics of blockchain technology. Additionally, the architecture integrates task-specific sharding to enhance the blockchain network’s ability to efficiently process knowledge base update transactions, significantly improving transaction throughput.

**Blockchain consensus mechanism based on DL:** Li et al. [217] introduce a novel blockchain consensus mechanism called DL-Based Consensus to address the challenges posed by large models and training datasets. The proposed method harnesses the computational power of blockchain miners for DL training and replaces the traditional proof-of-work hash computation with a Proof-of-Useful-Work approach, overcoming the limitations of conventional consensus mechanisms. To protect the ownership of DL models, they employ the DNN-watermark technique, which embeds a unique watermark within the model to verify ownership and prevent unauthorized use or modification. This approach not only enhances model security but also reduces

the energy consumption and computational resource waste associated with blockchain operations, offering a more efficient solution for blockchain-based DL applications.

#### *4.7.2. Prevent Node Leakage*

Each node plays an important role in the blockchain network and is responsible for maintaining and running the blockchain, including validation, storage and dissemination of data. The large number of nodes in IoT is a key reason for security issues, as leakage of a single node reduces the security of the entire network.

**Secure blockchain node design scheme:** To address the security of nodes, Liang et al. [218] proposed a blockchain node design scheme, which is mainly centered on building a Smart Efficient Secure and Scalable intrusion detection system for the Internet of Things. The proposed system integrates five core components: a blockchain smart contract module, detection and analysis module, response module, data processing module, and collection module. Smart contracts define and enforce communication rules between nodes, ensuring compliance with predefined behaviors. By embedding databases and blockchain nodes, the system enhances data storage and retrieval efficiency. Localized data processing between nodes minimizes communication overhead while leveraging blockchain technology to maintain data consistency and security. The system employs the Elliptic Curve Digital Signature Algorithm to encrypt public and private keys, ensuring that only authorized nodes can generate or access specific communication messages. Encryption algorithms safeguard node communication against unauthorized access and tampering. All communication messages, including commands and feedback, must follow methods specified by smart contracts, with data integrity verified using the sender's public key, the data itself, and its digital signature before being accessed by the receiver. These design features enhance the effectiveness and security of blockchain-enabled nodes within IoT intrusion detection systems.

**Committee consensus mechanism:** Li et al. [219] present the Blockchain-based FL framework with Committee Consensus, an innovative solution to the security challenges in FL. This framework integrates blockchain technology for securely storing global models and local updates, safeguarding user data privacy while enabling collaborative model optimization. The federated blockchain structure features model blocks for storing global models and update blocks for recording local updates during each training round.

The core of the proposed method is the Committee Consensus Mechanism, which improves security and efficiency by restricting the consensus process to a selected group of nodes forming a committee. This design ensures that malicious actors must control more than half of the committee to influence the global model, thereby significantly enhancing resilience to attacks while reducing the computational cost of consensus. Nodes within the system actively contribute by accessing the global model and uploading updates, fostering mutual cooperation. To reinforce security, the framework enforces strict node management via an initial manager node, permitting only authenticated devices to participate. A blacklist-based approach effectively blocks malicious nodes, preventing unauthorized access. By addressing vulnerabilities associated with malicious clients and central servers, the proposed framework provides a robust, secure, and efficient solution for FL in decentralized environments.

**Blockchain-based hybrid architecture:** Desai et al. [207] introduce BlockFLA, a blockchain-based hybrid architecture designed to enhance the security and efficiency of FL. BlockFLA achieves this by evaluating each node’s model contributions to detect anomalous nodes involved in malicious activities. The architecture integrates a private chain and a public chain, each serving distinct purposes: the private chain functions as the aggregation server, while the public chain verifies node behavior and enforces penalties. In this system, nodes send hashes of their model updates to the public chain for verification. Smart contracts on the public chain automatically detect malicious activities and enforce penalties, such as forfeiting the deposit of the offending node and redistributing it to honest participants. Communication between nodes on the private chain is encrypted, ensuring the privacy of node data, while the tamper-proof transaction records on the public chain provide additional security and trust. By combining encrypted communication, tamper-resistant verification, and automated penalty mechanisms, BlockFLA establishes a secure and trustworthy FL environment, effectively mitigating the risks posed by malicious nodes and fostering reliable collaboration.

**Deep reinforcement learning-based node selection:** Lu et al. [220] propose a Deep Reinforcement Learning-based node selection algorithm to optimize the participation of nodes in a blockchain-enhanced asynchronous FL framework for IoV data sharing. This framework leverages asynchronous FL to allow nodes to train at varying speeds, eliminating delays caused by the slowest nodes and significantly enhancing system efficiency. It incorpo-

rates a hybrid blockchain architecture, PermiDAG, which combines a permissioned blockchain with a local Directed Acyclic Graph. In the local DAG, each vehicle node maintains its transaction records independently and synchronizes encrypted updates with neighboring vehicles, ensuring robust data privacy. This innovative approach improves the efficiency and security of FL in IoV environments, addressing challenges related to node participation, asynchronous training, and data privacy in decentralized systems.

#### 4.7.3. Model Framework Design

In addition to starting at the data level and the node level, the overall architecture of the model can be designed to achieve the purpose of ensuring network security. The blockchain model typically follows a layered architecture, structured from the bottom up into the data layer, network layer, consensus layer, incentive layer, contract layer, and application layer. It enhances the flexibility and scalability of blockchain systems, allowing them to effectively meet the demands of diverse application scenarios.

**Decentralized block-chained FL framework:** Kim et al. [221] propose Blockchained FL, an innovative decentralized ML framework that leverages blockchain technology to facilitate the exchange and verification of local model updates between devices. This framework eliminates the need for a central server or centralized training data, enabling on-device ML. In BlockFL, each device computes its local model updates and uploads them to miners within the blockchain network. The miners use a Proof-of-Work consensus mechanism to exchange and verify these updates, recording the validated updates on the blockchain. Subsequently, devices download the new blocks to compute global model updates, completing the FL process. By design, BlockFL enhances system robustness, mitigates single points of failure, and incentivizes wider participation by rewarding devices in proportion to the size of their training samples. Furthermore, the framework ensures data privacy and security, making it a promising approach for decentralized ML.

**Block-chain secure IoT framework:** Rathore et al. [222] propose BlockSecIoTNet, a decentralized security architecture designed to enhance the security of IoT networks within smart city environments. This innovative architecture integrates key technologies such as software-defined networking, blockchain, fog computing, and mobile edge computing, forming a layered model with distinct functions at each layer: data collection, traffic analysis, and attack detection and mitigation. Attack detection models are shared and

updated among fog nodes via smart contracts, thereby improving the accuracy of threat detection. Through this integrated approach, BlockSecIoTNet enables continuous monitoring and proactive analysis of potential security threats, providing optimized protection for IoT ecosystems in smart cities.

**Blockchain-based distributed learning framework:** Lugan et al. [223] introduce TCLearn, a blockchain-based distributed learning security architecture that is applicable to consortia with varying levels of trust, supporting both public and permissioned blockchains. TCLearn offers tailored security and privacy mechanisms for public learning models, private learning models, and untrusted consortium members. The architecture utilizes the Federated Byzantine Protocol to ensure both model performance and data privacy by enabling the secure evaluation and logging of model updates via blockchain. This approach fosters enhanced trust and security in distributed learning environments, ensuring the integrity and confidentiality of the learning process.

**Blockchain-based distributed learning security framework:** Awan et al. [224] introduces the Blockchain-assisted Privacy-Preserving FL framework, which integrates blockchain technology with FL to enhance data privacy and security. By leveraging blockchain’s immutability and decentralization, the framework ensures traceability and verification of model updates. It employs homomorphic encryption and proxy re-encryption techniques to securely aggregate client model updates without exposing local data. These updates are asynchronously recorded on the blockchain, addressing challenges such as random client dropouts. Additionally, the framework incorporates incentive mechanisms based on clients’ contributions to global model optimization and introduces value premiums for model ownership, rewarding participating miners. This approach fosters a more transparent, equitable, and secure collaborative learning environment.

**Point-to-point ML framework:** Shayan et al. [225] introduce Biscotti, a decentralized point-to-point ML framework designed to uphold data privacy and security in multi-party ML processes through the integration of blockchain technology and cryptographic techniques. The framework innovatively incorporates a Proof-of-Federation consensus protocol to filter and authorize key participants in the model update process. Furthermore, Biscotti employs differential privacy methods and secure multi-party computation techniques to mitigate data leakage risks and defend against model poisoning attacks. The system also adopts a verifiable secret sharing scheme to securely aggregate updates from multiple participants. By eliminating

the reliance on a centralized server, Biscotti effectively establishes a FL environment that safeguards against known attacks, ensures data privacy, and enhances model robustness.

**Lesson 7.** *In SemCom system, semantic information is inherently user-centric and user-generated, necessitating measures to preserve its value and safeguard it from unauthorized dissemination among participants during data mining processes. Integrating blockchain technology with SemCom can facilitate reliable updates to shared knowledge, foster trust among participants, and enhance the recognition of semantic information’s intrinsic value. Blockchain-enabled SemCom can be achieved from the data [213, 214, 215, 216, 217], node [218, 219, 207, 220], and model perspectives [221, 222, 223, 224, 225].*

#### 4.8. Model Compression

Model compression aims at reducing the size of DL models and enhancing the operational efficiency. This is generally achieved by minimizing the model’s computational requirements, such as the number of parameters and computational complexity, without compromising its accuracy significantly. The importance of model compression is paramount when deploying DL models on resource-constrained devices, such as mobile devices, embedded systems, or IoT devices, due to their limited memory, computational power, and battery life. By employing model compression techniques, devices can effectively decrease communication costs, conserve storage space, and eliminate parameter redundancy, thereby strengthening the SemCom system to defend against multi-party cooperation attacks. Model compression techniques can be divided into the following sub-categories: model pruning, parameter quantization, low-rank decomposition, and knowledge distillation.

##### 4.8.1. Model Pruning

Model pruning diminishes the size of neural networks by eliminating unnecessary connections or parameters while striving to preserve their performance to the fullest extent. Model pruning primarily falls into two categories: unstructured pruning and structured pruning. Unstructured pruning involves directly removing individual parameters or connections, particularly those with smaller weight values or neuron nodes. While this method can drastically decrease the number of model parameters and theoretical computation, the resulting pruned model is typically sparse and disrupts the original model structure, necessitating special hardware for acceleration. Conversely,



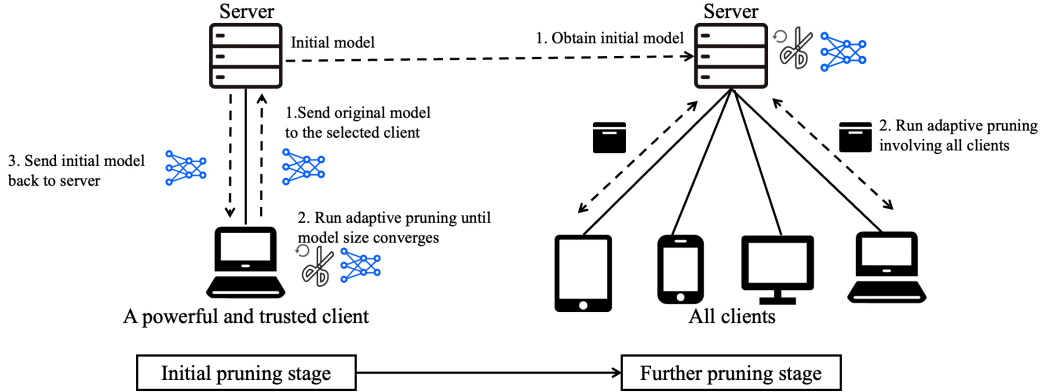

Figure 21: Combination of model pruning and FL [226].

structured pruning operates at the level of filters or entire network layers. When a filter is pruned, the preceding and subsequent feature maps will undergo corresponding changes, yet the model’s structure remains unaffected, enabling it to be accelerated by GPUs or other hardware. Structured pruning is more viable in practical applications.

**Combination with FL:** As depicted in Fig. 21, Jiang et al. [226] present a novel FL approach called PruneFL, which adapts the model size during the training process to reduce communication and computation overhead while maintaining similar accuracy to the original model. The approach includes initial pruning at a selected client and further pruning as part of the FL process, and the model size is adapted to maximize the approximate empirical risk reduction divided by the time of one FL round. Experiments on edge devices show that PruneFL significantly reduces training time compared to conventional FL, and the pruned model converges to an accuracy similar to the original model, also acting as a lottery ticket of the original model.

**Defense against model inversion attacks:** Ding et al. [227] introduce a Privacy-Oriented Pruning for Collaborative Inference (PATROL) scheme that uses privacy-oriented pruning to balance privacy, efficiency, and utility in collaborative inference. By deploying more layers at the edge and leveraging Lipschitz regularization and adversarial reconstruction training, PATROL reduces the risk of model inversion attacks and enhances the target inference model.

**Defense against membership inference attacks:** Wang et al. [228] propose a pruning algorithm that reduces model storage and computational operations while also improving resistance to membership inference attacks. Experimental results demonstrate that the proposed algorithm can find a

subnetwork that prevents privacy leakage and achieves competitive accuracy compared to the original DNNs, with attack accuracy reduced by up to 13.6% and 10% compared to the baseline and Min-Max game, respectively. Yuan et al. [229] conducts the first analysis of privacy risks in the context of membership inference attacks and proposes a self-attention membership inference attack against pruned neural networks. Experiments show that the proposed attack performs better than existing attacks on pruned models. Additionally, the paper proposes a new defense mechanism to protect the pruning process by mitigating prediction divergence based on KL-divergence distance, which effectively mitigates privacy risks while maintaining sparsity and accuracy of the pruned models.

**Defense against adversarial attacks:** Ye et al. [230] propose a framework of concurrent adversarial training and weight pruning to enable model compression while preserving adversarial robustness, addressing the dilemma of adversarial training. The study finds that weight pruning is essential for reducing network model size in the adversarial setting, and training a small model from scratch cannot achieve either adversarial robustness or high standard accuracy. Wu et al. [147] combines adversarial training and model pruning in a joint formulation during training to address both model size and robustness against attacks. The method eliminates the need for heuristics and pre-trained models, enabling better compression and robustness.

#### 4.8.2. Parameter Quantization

Parameter quantization transforms the parameters within a neural network from high-precision formats (such as 32-bit floating-point numbers) to low-precision formats (such as 8-bit integers or even lower), with the objective of decreasing the model’s computational and storage resource demands while preserving its performance levels [231].

**Comparison between quantization aware training and post training quantization:** Nagel et al. [232] introduce advanced algorithms to mitigate the impact of quantization noise on neural network performance while maintaining low-bit weights and activations. They discuss two main classes of algorithms: post-training quantization and quantization-aware-training. As illustrated in Fig. 22, post-training quantization is a lightweight approach that requires no re-training or labeled data and is sufficient for achieving 8-bit quantization with close to floating-point accuracy. Quantization-aware-training requires fine-tuning and access to labeled training data but enables lower bit quantization with competitive results.

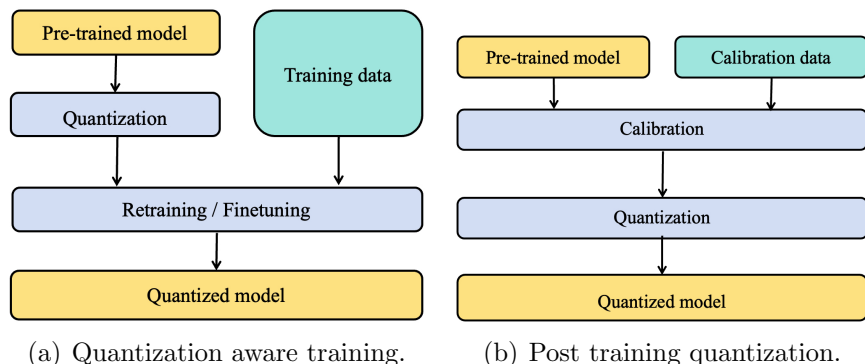

Figure 22: Comparison between quantization aware training and post training quantization [231].

**Consideration of discretization errors between inputs and outputs of the discretizer:** Lee et al. [233] consider discretization errors and propose the element-wise gradient scaling method, which adaptively scales each gradient element based on its sign and the error between the continuous input and discrete output of the discretizer. They demonstrate the effectiveness of the proposed method through extensive experimental results on image classification datasets with diverse network architectures and bit-width settings.

**Asymmetric quantization:** Bhalgat et al. [234] propose LSQ+, an extension of LSQ that introduces a general asymmetric quantization scheme with trainable scale and offset parameters to accommodate negative activations. LSQ+ also alleviates the problem of high instability or variance in final training performance commonly seen in gradient-based learnable quantization schemes by using an MSE-based initialization scheme for the quantization parameters.

**Quantization for large language models:** Shao et al. [235] introduce OmniQuant, a technique that achieves good performance in diverse quantization settings while maintaining the computational efficiency of post-training quantization. OmniQuant includes two innovative components, learnable weight clipping and learnable equivalent transformation, which optimize various quantization parameters efficiently within a differentiable framework using block-wise error minimization. Xu et al. [236] propose a quantization-aware low-rank adaptation algorithm that balances the degrees of freedom of quantization and adaptation using group-wise operators. The designed al-

gorithm can quantize weights during fine-tuning to reduce time and memory usage, and naturally integrates large language models and auxiliary weights into a quantized model without loss of accuracy.

#### 4.8.3. *Low-Rank Decomposition*

Low-rank decomposition breaks down a large matrix into the product of two or more smaller, simpler matrices that generally possess lower ranks, subsequently decreasing the number of model parameters and mitigating the computational burden.

**Combination with sparsity:** Swaminathan et al. [237] introduce a new method called sparse low rank for compressing DNNs, which combines the ideas of low-rank decomposition and neuron significance. The proposed method achieves better compression rates by sparsifying the singular value decomposition matrices and keeping lower rank for unimportant neurons. Experimental results show that the proposed approach outperforms vanilla truncated SVD and a pruning baseline, achieving better compression rates with minimal or no loss in accuracy. Xue et al. [238] propose a multi-layer sparsity-based tensor decomposition method for low-rank tensor completion. The method aims to depict complex hierarchical knowledge with implicit sparsity attributes hidden in a tensor by encoding structured sparsity through multiple-layer representations. Specifically, it uses the CAN-DECOMP/PARAFAC model for tensor decomposition and introduces a new sparsity insight of subspace smoothness as the third-layer sparsity.

**Degeneracy in the tensor decomposition of convolutional kernels:** Phan et al. [239] introduce a novel method to stabilize the low-rank approximation of convolutional kernels in DNNs, addressing the issue of degeneracy in tensor decomposition. The proposed method ensures efficient compression while preserving the high-quality performance of the neural networks. This study is the first to address degeneracy in the tensor decomposition of convolutional kernels.

**Selection of optimal rank in each layer:** Idelbayev et al. [240] propose a mixed discrete-continuous optimization approach to jointly optimize the ranks and matrix elements, resulting in better rank selection. This makes low-rank compression more attractive and demonstrates its effectiveness by achieving similar classification error with faster inference times compared to ResNet using a VGG network.

**Domain generalization:** Piratla et al. [241] propose a common specific decomposition method for domain generalization, which jointly learns a

common component that generalizes to new domains and a domain-specific component that overfits on training domains. The domain-specific components are discarded after training, and only the common component is used for prediction.

#### 4.8.4. Knowledge Distillation

Knowledge distillation leverages a pre-trained, more sophisticated teacher model to instruct the training of a streamlined student model. Throughout the training phase, the student model mimics the predictive behavior of the teacher model, effectively decreasing the model’s size and parameter count while striving to retain the teacher model’s accuracy levels. Based on whether the teacher model is updated concurrently with the student model, the learning frameworks can be categorically divided into offline distillation, online distillation, and self-distillation.

**Offline distillation:** Considering that the performance of the smaller student network can degrade when the gap between the student and teacher network sizes is too large, Mirzadeh et al. [242] introduce the multi-step knowledge distillation, which uses an intermediate-sized network to bridge the gap between the student and teacher. Theoretical analysis and experiments on various datasets and architectures demonstrate the effectiveness of this approach. Asif et al. [243] present a framework for learning compact CNN models with improved classification performance and generalization using a student model with parallel branches trained using ground truth labels and information from high-capacity teacher networks. The framework provides two benefits: promoting heterogeneity in learning features and encouraging collaboration among branches to improve prediction quality.

**Online distillation:** Wu et al. [244] propose a peer collaborative learning method for online knowledge distillation, which integrates online ensemble and network collaboration into a unified framework. By constructing a multi-branch network for training, where each branch is a peer, and using random augmentation and an additional classifier to assemble feature representations as the peer ensemble teacher, the method transfers knowledge from a high-capacity teacher to the peers and optimizes the ensemble teacher. Additionally, the temporal mean model of each peer is used as the peer mean teacher to facilitate collaboration among peers, leading to richer knowledge transfer and better generalization. Zhang et al. [245] propose the adversarial co-distillation network to enhance the “dark knowledge” in co-distillation by generating extra divergent examples using only the standard

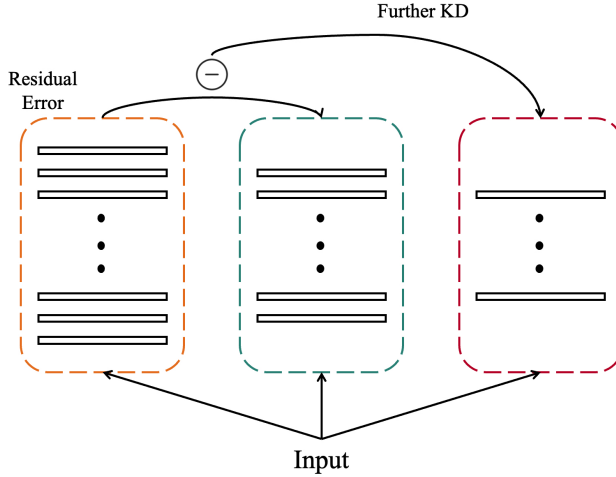

Figure 23: Residual error based knowledge distillation [247].

training set. The designed end-to-end approach consists of an adversarial phase with GANs to generate divergent examples and a co-distillation phase with multiple classifiers to learn from these examples. The two phases are learned in an iterative and adversarial way, and additional modules are designed to ensure the quality of divergent examples.

**Self-distillation:** Zhang et al. [246] offer a new interpretation of teacher-student training as amortized MAP estimation and relate self-distillation to label smoothing, emphasizing the importance of predictive diversity in addition to predictive uncertainty. Experimental results demonstrate the utility of predictive diversity across multiple datasets and neural network architectures. They propose a novel instance-specific label smoothing technique that promotes predictive diversity without a separately trained teacher model and find that it often outperforms classical label smoothing. As illustrated in Fig. 23, Gao et al. [247] propose the residual error based knowledge distillation to address the performance degradation in knowledge distillation due to the gap between the learning capacities of the student and teacher models. The proposed method introduces an assistant model to learn the residual error between the feature maps of the student and teacher, allowing them to complement each other and better transfer knowledge from the teacher. An effective method is further devised to derive the student and assistant models from a given model without increasing the total computational cost.

**Defense against adversarial attacks:** Papernot et al. [248] propose the defensive distillation to reduce the effectiveness of adversarial samples on DNNs. Analytical investigation shows that defensive distillation grants

generalizability and robustness properties when training DNNs. Empirical studies demonstrate that defensive distillation can significantly reduce the effectiveness of adversarial sample creation. Ham et al. [249] propose the NEO-KD, a knowledge distillation-based adversarial training strategy, to improve the robustness of multi-exit neural networks against adversarial attacks. NEO-KD uses neighbor knowledge distillation to guide the output of adversarial examples to tend to the ensemble outputs of neighbor exits of clean data, and employs exit-wise orthogonal knowledge distillation to reduce adversarial transferability across different sub-models.

**Lesson 8.** *Model compression reduces the size and enhances the efficiency of DL models by minimizing computational requirements without compromising accuracy significantly. Its importance is crucial for deploying Deep JSCC models on resource-constrained devices, as it helps decrease communication costs, conserve storage, and strengthen SemCom systems against multi-party cooperation attacks. Model compression can be achieved through model pruning, parameter quantization, low-rank decomposition, or knowledge distillation. Specifically, model pruning can be designed to defend against model inversion attacks [227], membership inference attacks [228, 229], and adversarial attacks [230, 147]. Parameter quantization can be divided into quantization aware training and post training quantization [232, 231], and the applications can be extended to task oriented SemCom [233] and large knowledge base [235, 236]. Low-rank decomposition can be divided into the following sub-problems: sparsity-enabled decomposition [237, 238], decomposition of convolutional kernels [239], decomposition of each layer in deep JSCC models [240], and task-oriented SemCom [241]. Knowledge distillation can be divided into offline [242, 243], online [244, 245], and self distillation [246, 247], and it is effective to defend against adversarial attacks [248, 249].*

#### 4.9. Physical-Layer Security

Physical-layer security (PLS) involves utilizing the randomness of wireless channels, such as interference, fading, and noise, to ensure secure transmission. Shannon proposed the concept of “perfect secret”, which can be extended to “perfect semantic secret” in SemCom as

$$I(M_S; C_S) = 0 \quad (5)$$

where  $M_S$  is the semantic information at the transmitter.  $C_S$  represents the encrypted semantic features, that is, the observation of semantic eavesdroppers. Perfect semantic secret necessitates that the mutual information

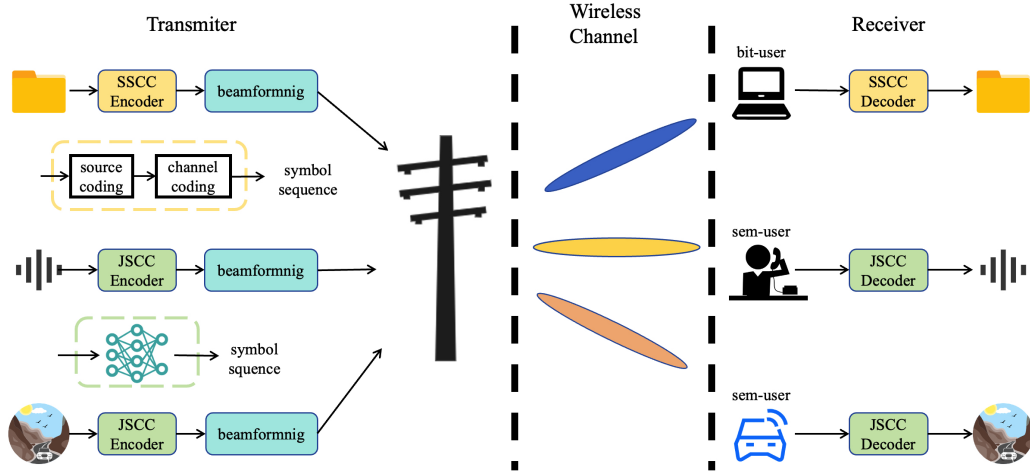

Figure 24: Semantic-bit coexisting communication framework [250].

between  $M$  and  $C$  is zero. If the condition of perfect semantic secret is met, semantic eavesdroppers can only recover the original semantic information from the encrypted semantic characteristics through random guessing, as it represents the optimal strategy. The various random factors present in wireless communications can be effectively harnessed to establish the comparative advantages of legitimate semantic transmission and ensure the security of SemCom. The related PLS techniques include beamforming, artificial noise, relay cooperation, Intelligent reflecting Surface (IRS), physical-layer key generation (PLKG), and physical-layer authentication (PLA), which are described in detail as follows.

#### 4.9.1. Beamforming

Beamforming technology primarily utilizes multi-antenna systems to form beams with specific directionality by precisely controlling the phase and amplitude of the transmission signals from each antenna in the array. This technology can substantially enhance the signal strength for the intended receiver while suppressing signal transmission in other directions, thus diminishing the received signal quality for eavesdroppers.

**Semantic-bit coexisting environment:** As illustrated in Fig. 24, Zhang et al. [250] introduces a semantic-bit coexisting communication framework and proposes a spatial beamforming scheme to address the heterogeneous inter-user interference issue. To maximize the semantic rate for SemCom users while ensuring QoS for BitCom users, a data-driven method and majorization minimization are employed to derive a semi-closed form so-



lution. Additionally, a low-complexity version of the MM-FP algorithm is proposed to reduce computational complexity, and simulation results demonstrate the superiority of both algorithms compared to conventional beamforming techniques.

**Massive MIMO applications:** Wu et al. [251] proposes a deep joint semantic coding and beamforming scheme for airship-based massive MIMO image transmission networks in near-field communication networks. By integrating SemCom with massive MIMO technology, the scheme aims to improve transmission efficiency and capacity. The proposed scheme extracts semantics from both the image source and channel state information, fuses them into complex-valued semantic features, and then employs hybrid data and model-driven semantic-aware beamforming networks for efficient transmission. At the receiver, a semantic decoding network reconstructs the transmitted images.

**Varying environmental conditions:** Raha et al. [252] develops a semantic-based method to enhance the robustness of beamforming in 6G wireless communication, particularly for high-mobility applications like intelligent transportation systems and virtual reality platforms. The proposed method utilizes the YOLOv8 algorithm to extract semantic data from RGB camera images and K-means clustering with GPS data to identify target vehicles. A lightweight model is used to predict the optimal beamforming index to maintain ultra-reliable low-latency communication. Raha et al. [253] further proposes a robust beamforming technique to ensure consistent Quality of Service (QoS) under varying environmental conditions in 6G. The proposed technique leverages semantic localization and optimal beam selection problems to maximize users' data rates. A novel method using K-means clustering and YOLOv8 model is proposed to solve the semantic localization problem, while a lightweight hybrid architecture combining a transformer and CNN is proposed to solve the beam selection problem. A novel metric, Accuracy-Complexity Efficiency, is introduced to quantify the performance of the proposed model.

#### 4.9.2. Artificial Noise

Artificial noise technology involves adding intentional and pseudo-random noise to the transmission signals to interfere with eavesdroppers. This noise has minimal impact on legitimate receivers but can drastically reduce the received signal-to-noise ratio for eavesdroppers, thereby safeguarding the security of information.

**Optimal beamforming:** Zhang et al. [254] provide a layered PLS model to secure multiple messages simultaneously with a cascade security structure. An artificial-noise-aided optimal beamforming scheme is proposed for a two-layer unicast system to maximize high-level information security while adhering to low-level secrecy constraints. A successive convex approximation-based algorithm is used to address the nonconvexity of the problem, and a low-complexity zero-forcing beamforming scheme is introduced for efficiency.

**Cognitive radio network applications:** Jiang et al. [255] proposes two secrecy energy efficiency maximization schemes for energy-efficient secure downlink communication in OFDM-based cognitive radio networks with an eavesdropper having multiple antennas. The proposed schemes exploit the instantaneous and statistical CSI of the eavesdropper, respectively, to defend against eavesdropping and improve energy efficiency. The problems are transformed into equivalent subtractive problems and then approximate convex problems using the difference of two convex functions approximation method. Two-tier power allocation algorithms are proposed to achieve  $\epsilon$ -optimal solutions.

**Cellular vehicle-to-everything network applications:** Wang et al. [256] investigates the potential of artificial noise and secure beamforming for enhancing the security of cellular vehicle-to-everything networks. Using stochastic geometry, the PLS is studied, with locations of nodes modeled by Cox processes and Poisson point processes. The coverage probability and bounds on the secrecy probability are calculated and validated by simulation results. Analytical results on effective secrecy throughput are also obtained, demonstrating the reliability and security of wiretap channels.

**Visible light communication applications:** Pham et al. [257] explores energy-efficient artificial noise schemes for enhancing PLS in visible light communications. Two transmission schemes, selective artificial noise-aided single-input single-output and artificial noise-aided multiple-input single-output, are compared in terms of secrecy energy efficiency. In the former, the closest LED luminaire to the legitimate user transmits the information-bearing signal, while the rest transmit artificial noise to degrade eavesdroppers' channels. In the latter scheme, all luminaries transmit a combination of the information-bearing signal and artificial noise. When eavesdroppers' CSI is unknown, an indirect design to maximize the legitimate user's channel energy efficiency is proposed, along with a low-complexity zero-forcing design. When eavesdroppers' CSI is known, the design maximizes the minimum secrecy energy efficiency among all eavesdroppers.

### 4.9.3. Relay Cooperation

Relay cooperation enhances SemCom performance by facilitating multiple nodes to share and utilize each other's resources during semantic information transmission. This technology holds a pivotal role in ensuring PLS. By harnessing the intricate spatial domain characteristics formed by multiple relay nodes, the received signals at these nodes can be regulated through adjustments to the antenna transmission weights. The legitimate receiver consolidates all the content relayed to obtain the original information and achieve diversity gain, whereas the signal captured by a solitary relay node incorporates random weighting, rendering it infeasible to accurately reconstruct the semantic information content.

**Semantic text transmission:** Luo et al. [258] introduce a SemCom scheme for wireless relay channels called, which uses an Autoencoder for encoding and decoding sentences from the semantic dimension. The Autoencoder provides anti-noise performance for the system. Additionally, a novel semantic forward mode is designed for the relay node to forward semantic information at the semantic level, particularly in scenarios where the source and destination nodes do not share common knowledge. Hu et al. [259] propose the semantic relay to address the challenges of implementing resource-demanding DL-based SemCom on mobile devices with limited computing and storage resources. The semantic relay serves as an edge server to provide SemCom services for both semantic users with rich resources and conventional users with limited resources. Two new transmission protocols are proposed for text transmissions via the semantic relay, and an optimization problem is formulated to maximize the weighted sum-rate of all users. An efficient algorithm is proposed to solve this non-convex problem, and numerical results demonstrate the effectiveness of the proposed algorithm and the superior performance of the semantic relay compared to traditional decode-and-forward relays, especially in the small bandwidth regime.

**Cooperative SemCom:** Tang et al. [260] proposes a DL-based cooperative SemCom system on relay channels that enhances reliability and adaptability to varying channel conditions through an on-demand semantic forwarding framework. The system uses a semantic similarity check to determine whether semantic forwarding is needed from the relay and a semantic combining method to effectively merge semantic information received through different paths. Additionally, a new metric called semantic energy efficiency is proposed to balance the degree of semantic information recovery

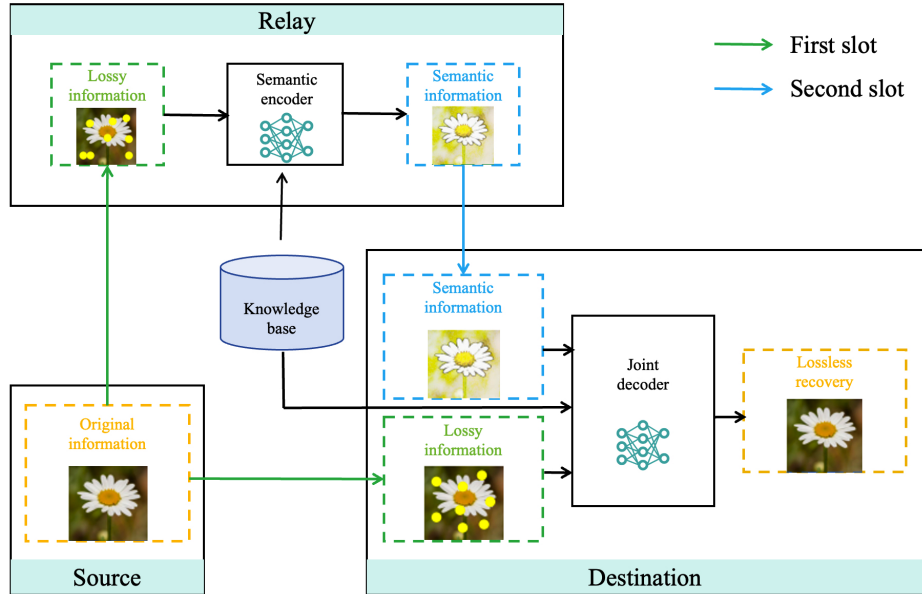

Figure 25: Semantic-forward for cooperative communications [261].

and transmit energy consumption. As depicted in Fig. 25, Lin et al. [261] introduce a relaying framework called semantic-forward for cooperative communications in 6G wireless networks. The semantic-forward relay reduces payload and enhances network robustness by extracting and transmitting semantic features. A joint source-channel coding algorithm is designed based on cooperative communications with side information and the turbo principle to improve decoding gains.

**Multimodal SemCom:** Guo et al. [262] introduce the distributed task-oriented communication networks that leverages multimodal semantic transmission and edge intelligence to improve task performance. The framework integrates multimodal knowledge of semantic relays and adaptive adjustment capability of edge intelligence. Key techniques in the framework include semantic alignment and complement, a semantic relay scheme for deep joint source-channel relay coding, and collaborative device-server optimization and inference.

#### 4.9.4. Intelligent Reflecting Surface

IRS constitutes a planar structure comprised of numerous programmable reflecting units, capable of dynamically tuning the phase, amplitude, and frequency attributes of reflected electromagnetic waves. Through intelligent control of these units, the IRS attains precise management of incident electro-

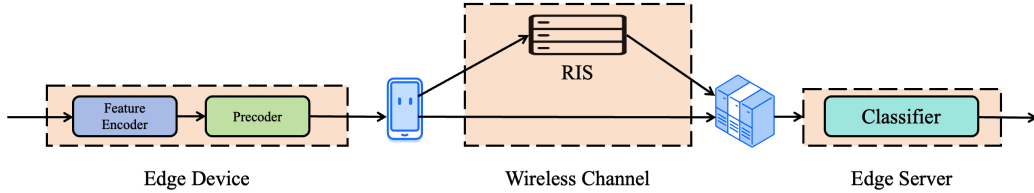

Figure 26: Unified framework for IRS-aided SemCom systems [265].

magnetic waves, thereby modifying the transmission properties of the wireless channel. This functionality allows the IRS to emerge as a potent tool for PLS, bolstering the confidentiality of communications by fashioning a programmable wireless environment. In scenarios involving eavesdroppers, the IRS can seamlessly collaborate with the base station’s beamformer and adjust its own reflection phase shifts to maximize the system’s minimum secrecy rate. By effectively reducing the SNR of eavesdroppers while enhancing the SNR of legitimate receivers, the IRS notably elevates the confidentiality performance of wireless systems.

**Task-oriented SemCom:** Du et al. [263] propose a new paradigm called inverse SemCom, which encodes task-related source messages into a hyper-source message for data transmission or storage, instead of extracting semantic information from messages. The proposed framework includes three algorithms for data sampling, IRS-aided encoding, and self-supervised decoding. Wang et al. [264] propose an IRS-enhanced secure SemCom to ensure PLS from a task-oriented semantic perspective. The paper introduces a multi-layer codebook for hierarchical semantic representation and defines novel semantic security metrics, secure semantic rate and secure semantic spectrum efficiency. Additionally, a noise disturbance enhanced hybrid deep reinforcement learning-based resource allocation scheme is proposed to maximize secure semantic spectrum efficiency by optimizing semantic representation bits, IRS reflective coefficients, and subchannel assignment. A semantic context aware state space is also introduced to solve the dimensional catastrophe problem. As illustrated in Fig. 26, Huang et al. [265] propose a unified design framework for IRS-aided SemCom systems tailored for classification tasks. The framework is based on the Infomax principle, which aims to maximize the mutual information between the received feature and the label of the input data sample. Unlike end-to-end training, the proposed approach decouples the learning and communication modules, allowing for a more efficient design of feature encoding, joint active and passive beamforming, and classification.

**Discussion on data and control flow:** Chen et al. [266] offer the paradigm of IRS-based on-the-air SemCom to enable SemComs in the wave domain, leveraging IRSs and on-the-air diffractive DNNs. The computations in this scheme occur inherently as wireless signals pass through IRSs, offering light-speed computation, low power consumption, and the ability to handle multiple tasks simultaneously. This scheme presents a system model, discusses data and control flow issues, and provides a performance analysis with image transmission as an example. Overall, IRS-based SemCom offer appealing characteristics compared to traditional digital hardware-based approaches.

**Defense against eavesdroppers:** Wang et al. [267] propose the use of a simultaneous transmitting and reflecting reconfigurable intelligent surface (STAR-RIS) to achieve privacy protection in a SemCom system. The STAR-RIS is used to enhance signal transmission between a base station and a destination user, while converting the signal to interference for an eavesdropper. Simulation results show that the proposed method outperforms other benchmarks in protecting SemCom privacy, as evidenced by a significantly lower task success rate achieved by the eavesdropper.

#### 4.9.5. *Physical-Layer Key Generation*

PLKG hinges on leveraging the reciprocity, temporal variability, and spatial decorrelation properties of wireless channels. In the realm of SemCom, the inherent complexity and randomness of the channel environment enable both communicating parties to capture highly correlated channel characteristics through a shared channel. These channel characteristics, which fluctuate with time and space, introduce a level of randomness and enhance the eavesdropping resistance of the physical layer keys.

**Static environment applications:** Aldaghri et al. [268] introduce a low-complexity method called induced randomness for high-rate secret key generation in wireless communication systems, even in static environments. This method leverages the uniqueness of wireless channel coefficients and locally generated randomness by the communicating parties, Alice and Bob. The work considers two scenarios: direct communication between Alice and Bob, and communication through an untrusted relay. Post-processing is done to generate highly-correlated samples that are converted into bits, and disparities are mitigated. Hashing is used to compensate for information leakage to an eavesdropper and to ensure consistency of the generated key bit sequences.

**Frequency-division duplexing system applications:** Zhang et al. [269] develop a PLKG scheme for frequency-division duplexing systems in IoT. The scheme uses DL to establish a feature mapping function between different frequency bands, enabling two users to generate highly similar channel features. The proposed key generation neural network demonstrates excellent performance in terms of randomness, key generation ratio, and key error rate, and is suitable for resource-constrained IoT devices in frequency-division duplexing systems.

**IRS-assisted PLKG:** Jin et al. [270] propose a IRS-assisted PLKG scheme to significantly enhance key generation performance. By optimizing reflecting coefficients and formulating a power minimization problem, the scheme achieves a higher key generation rate and reduced transmit power compared to existing relay-assisted schemes. Gao et al. [271] presents an overview of IRS-aided PLKG in static indoor environments, highlighting its channel model, hardware architectures, potential application scenarios, and design challenges. Experimental results demonstrate that the key generation rate is significantly enhanced by using IRS in a static indoor environment. Zhao et al. [272] develop the SemKey to significantly improve the secret key generation rate for SemCom by exploring the underlying randomness of the system and utilizing IRS. This can potentially pave the way for PLS, addressing the vulnerability of these systems to various attacks due to the openness of wireless channels and the fragility of neural models.

#### 4.9.6. Physical-Layer Authentication

PLA utilizes the unique propagation characteristics of the wireless environment or the inherent hardware attributes of access devices to realize the verification of the transmitter's identity [273]. In comparison to upper-layer authentication methods, PLA offers notable advantages, including reduced complexity, accelerated authentication processes, minimized latency, and increased resistance to forgery. This approach significantly enhances the reliability of information transmission and introduces innovative perspectives for achieving secure SemCom.

**Environment semantics-enabled PLA:** As illustrated in Fig. 27, Gao et al. [274] propose an environment semantics enabled PLA network, EsaNet, for 6G endogenous security. The network extracts a frequency independent wireless channel fingerprint from CSI in a massive MIMO system using environment semantics knowledge. The received signal is transformed into an RGB image and processed by a YOLO network to quickly capture the fre-

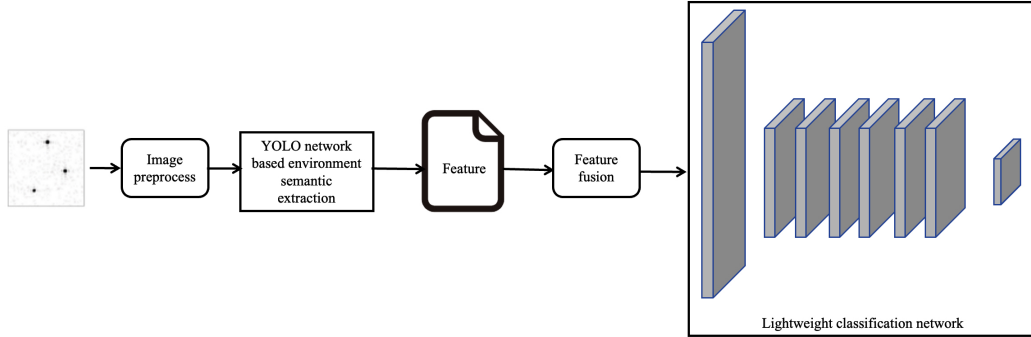

Figure 27: Environment semantics enabled PLA [274].

quency independent wireless channel fingerprint. A lightweight classification network is then used to distinguish legitimate from illegitimate users. Experimental results demonstrate that EsaNet can effectively detect physical layer spoofing attacks and is robust in time-varying wireless environments.

**Generative AI-enabled PLA:** Meng et al. [275] present a PLA scheme named hierarchical variational autoencoder (HVAE) for IIoT, which achieves high authentication performance without requiring attackers’ prior channel information. The HVAE consists of an AE module for CIR characteristics extraction and a VAE module for improving representation ability and outputting authentication results. A new objective function considering both single-peak and double-peak Gaussian distributions is constructed in the VAE module. Simulations under static and mobile IIoT scenarios demonstrate the superiority of the proposed HVAE over other PLA schemes, even with limited training data.

**Multiuser PLA:** Meng et al. [276] present a multiuser authentication architecture named multiobservation-multichannel-attribute-based authentication for IIoT that enhances wireless security by considering both multi-receiver observations and multiple channel attributes. The proposed architecture provides additional spatial recognition characteristics for multi-users and two gradient boosting optimization-based schemes are proposed to better fit the channel features of multi-observations. Meng et al. [277] further propose a multiattacker detection architecture using multidimensional fingerprints for more robust device identification. Four clustering-based PLA schemes that do not require training fingerprint sets are introduced. To enhance precision, graph learning-based PLA approaches with minimal labeled fingerprints are also proposed.

**Watermark-based active PLA:** Ma et al. [278] propose a pseudo-random watermark hopping-based PLA scheme to enhance both security and



communication performance. By generating a pseudo-random sequence and designing a watermark hopping mechanism, the scheme increases randomness and security while also reducing authentication latency and improving communication performance. The scheme superimposes the tag on pilot signals, avoiding the need for message recovery before authentication. Theoretical and experimental results show that the proposed scheme decreases the bit error rate, outage probability, and increases the achievable rate of the system while significantly improving security performance.

**Lesson 9.** *PLS leverages the randomness of wireless channels to ensure secure transmission. Shannon’s concept of “perfect secret” extends to “perfect semantic secret” in SemCom, ensuring eavesdroppers can only recover original information through random guessing. Various PLS techniques, including beamforming, artificial noise, relay cooperation, IRS, PLKG, and PLA, can be harnessed to establish secure semantic transmission. Beamforming can be leveraged in semantic-bit coexisting environments [250], massive MIMO applications [251], and varying environmental conditions [252, 253]. Artificial noises can be used to optimal beamforming [254], and are extended to cognitive radio network [255], cellular vehicle-to-everything network [256], and visible light communication applications [257]. Relay cooperation is effective for semantic text transmission [258], Cooperative SemCom [260, 261], and Multimodal SemCom [262]. IRS can be combined with other PLS techniques, such as artificial noise [279], PLKG [270, 271, 272], and PLA [280].*

## 5. Future Research Directions

### 5.1. Dynamic and Intelligent Data Cleaning

The future of data cleaning technique will evolve from static preprocessing towards dynamic and intelligent methods. Gradually, dynamic cleaning methods that integrate knowledge graphs and DL will facilitate a comprehensive upgrade of SemCom systems in intricate scenarios. Future research endeavors will concentrate on multimodal data integration, real-time semantic analysis, and cross-domain knowledge inference, thereby further advancing the application of SemCom technology in diverse fields such as healthcare, autonomous driving, and smart cities.

### 5.2. Explainable Robust Learning

The robustness and interpretability of deep JSCC models are interrelated. On one hand, enhancing the robustness of JSCC models helps it better cope

with various noises and outliers, thereby maintaining stable performance. On the other hand, improving its interpretability aids in better analyzing the basis for its decisions, which in turn facilitates the identification and resolution of robustness issues within the deep JSCC model. Through interpretability research, it becomes easier to pinpoint errors in semantic understanding and to carry out targeted optimizations and improvements.

### *5.3. Multi-Strategy Combined Backdoor Defense*

As technology progresses, the forms and techniques of backdoor attacks are continually evolving. Attackers may employ diverse trigger patterns, injection methods, and attack targets to execute these attacks, making them highly varied and intricate. Consequently, a solitary defense strategy often falls short in adequately addressing the multifaceted nature of backdoor attacks. A defense approach that integrates multiple strategies can comprehensively consider security needs from various perspectives and defend against backdoor attacks from multiple angles. For example, data cleaning ensures the authenticity and integrity of training data, mitigating the impact of tampered or injected malicious data on deep JSCC models. Enhancing the robustness of deep JSCC models and applying pruning and compression techniques can bolster their resistance to malicious attacks, reducing redundancy and the risk of being compromised. Additionally, backdoor detection technology can swiftly identify and eliminate backdoors, thereby ensuring the security of deep JSCC models. Therefore, the defense method that combines multiple strategies not only prioritizes the security of individual models or components but also takes into account the interactions and impacts among various components from the perspective of the entire SemCom system, ultimately enhancing the overall security and stability of SemComs.

### *5.4. Differential Privacy-based Deep JSCC*

While differential privacy offers robust mathematical foundations and the capability to quantify and analyze privacy leakage risks, ensuring the accuracy and efficiency of SemCom while safeguarding privacy presents a formidable challenge. The incorporation of differential privacy may introduce additional data noise, potentially compromising the precision and efficiency of SemCom. Moreover, as datasets expand in size and queries become increasingly intricate, computational complexity escalates, further elevating the requirements for implementing differential privacy in SemCom systems.

Consequently, future research endeavors will concentrate on integrating differential privacy techniques into deep JSCC processes, aiming to effectively extract semantic information while preserving privacy. Additionally, to mitigate the potential performance degradation associated with differential privacy in SemCom, future research will delve into optimization strategies for privacy protection mechanisms, encompassing adaptive differential privacy and local differential privacy.

#### *5.5. Efficient Homomorphic Encrypted SemCom*

Although homomorphic encryption offers the potential to achieve privacy protection without significantly impacting the performance of SemCom, its high complexity can pose challenges for certain terminals. Future research endeavors will focus on optimizing encryption algorithms and minimizing computational overhead. This includes exploring novel encryption algorithms that support a broader range of operations and fine-tuning encryption parameters, such as key length and ciphertext size, to enhance execution efficiency. Additionally, efforts will be made to reduce computational overhead by leveraging multi-core processors or distributed computing systems, as well as designing specialized hardware, such as FPGAs and ASICs, to expedite execution.

#### *5.6. Smart Contract-Enabled SemCom*

Research on SemCom empowered by smart contracts encompasses a range of areas, including data access control, verification of SemCom protocols, and anomaly detection. Specifically, this involves the design of permissions and rules for data access, ensuring that only users or devices meeting specific conditions can access sensitive semantic data. Furthermore, smart contract rules will be devised for verifying SemCom protocols, aiming to enhance the reliability and efficiency of the communication process. Additionally, strategies for monitoring and analyzing SemCom data will be developed to detect anomaly patterns, such as unusual semantic data traffic, transmission delays, or signs of semantic data tampering. Upon detecting such anomalies, smart contracts can swiftly trigger alerts and implement corresponding security measures, such as isolating affected nodes or terminating SemCom sessions to safeguard the integrity and security of SemCom systems.

### 5.7. Semantic Channel Fingerprint Database-Enabled PLS

The semantic channel fingerprints in the semantic channel fingerprint database can serve as a basis for authentication. When a device attempts to access the network, it only needs to compare its semantic channel characteristics with the information in the database to quickly determine its legitimacy. This significantly improves the efficiency and speed of identity authentication. Furthermore, the semantic channel characteristics in the semantic channel fingerprint database can be used as a basis for key generation. By extracting and analyzing the semantic channel characteristics of the device, related keys can be generated, thereby enabling secure key generation and distribution. In the future, the construction of the semantic channel fingerprint database will involve the extraction, description, and optimization of key semantic feature points, as well as the rapid retrieval, matching, and update management of the semantic channel fingerprint database.

## 6. Conclusion

When SemCom converges with 6G, it not only enhances communication efficiency but also introduces opportunities alongside challenges related to security and privacy issues. This article initially introduces the concept, architecture, and lifecycle of SemComs. Subsequently, it delves into the security and privacy concerns that arise during each phase of SemCom systems, encompassing knowledge base poisoning attacks, gradient leakage, server vulnerabilities, attacks targeting communication bottlenecks, model slice attacks, semantic adversarial attacks, semantic eavesdropping, semantic inference attacks, and semantic jamming attacks. Furthermore, we propose diverse techniques to counteract these security and privacy threats, such as data cleaning, robust learning, defensive strategies against backdoor attacks, adversarial training, differential privacy, cryptography, blockchain technology, model compression, and physical-layer security. Ultimately, we conclude the paper with recommendations and future research directions for these defense methods.

## 7. Acknowledgements

The work presented in this paper was supported by the National Key R&D Program of China No. 2020YFB1806900, the National Natural Science Foundation of China No. 61871045, No. 62401074, and No. 61932005,

Beijing Natural Science Foundation No. L242012 and No. L232051, the research foundation of Ministry of Education-China Mobile under Grant MCM20180101, and the Joint Research Fund for Beijing Natural Science Foundation and Haidian Original Innovation under Grant L232001.

## 8. CRediT authorship contribution statement

**Rui Meng:** investigation, methodology, writing, and supervision. **Song Gao:** investigation and writing. **Dayu Fan:** investigation and writing. **Haixiao Gao:** investigation and writing. **Yining Wang:** investigation and writing. **Xiaodong Xu:** writing (review and editing), funding acquisition, and supervision. **Bizhu Wang:** writing (review and editing) and funding acquisition. **Suyu Lv:** investigation and writing. **Zhidi Zhang:** investigation and writing. **Mengying Sun:** writing (review and editing) and funding acquisition. **Shujun Han:** writing (review and editing) and funding acquisition. **Chen Dong:** writing (review and editing) and funding acquisition. **Xiaofeng Tao:** writing (review and editing) and funding acquisition. **Ping Zhang:** funding acquisition and supervision.

## 9. Data availability

No data was used for the research described in the article.

## References

- [1] C.-X. Wang, X. You, X. Gao, X. Zhu, Z. Li, C. Zhang, H. Wang, Y. Huang, Y. Chen, H. Haas, et al., On the road to 6g: Visions, requirements, key technologies, and testbeds, *IEEE Communications Surveys & Tutorials* 25 (2) (2023) 905–974.
- [2] ITU-R, M.2160 : Framework and overall objectives of the future development of imt for 2030 and beyond (2023).  
URL <https://www.itu.int/rec/R-REC-M.2160/en>
- [3] P. Zhang, W. Xu, Y. Liu, X. Qin, K. Niu, S. Cui, G. Shi, Z. Qin, X. Xu, F. Wang, et al., Intellicise wireless networks from semantic communications: A survey, research issues, and challenges, *IEEE Communications Surveys & Tutorials* (2024).

- [4] C. E. Shannon, A mathematical theory of communication, *ACM SIGMOBILE mobile computing and communications review* 5 (1) (2001) 3–55.
- [5] X. Xu, B. Xu, S. Han, C. Dong, H. Xiong, R. Meng, P. Zhang, Task-oriented and semantic-aware heterogeneous networks for artificial intelligence of things: Performance analysis and optimization, *IEEE Internet of Things Journal* (2023).
- [6] B. Xu, R. Meng, Y. Chen, X. Xu, C. Dong, H. Sun, Latent semantic diffusion-based channel adaptive de-noising semcom for future 6g systems, in: *GLOBECOM 2023-2023 IEEE Global Communications Conference*, IEEE, 2023, pp. 1229–1234.
- [7] K. Niu, P. Zhang, A mathematical theory of semantic communication, *Journal on Communications* (2024) 1–52.
- [8] Y. Shao, Q. Cao, D. Gündüz, A theory of semantic communication, *IEEE Transactions on Mobile Computing* (2024).
- [9] G. Xin, P. Fan, K. B. Letaief, Semantic communication: A survey of its theoretical development (2024).
- [10] P. Zhang, X. Xu, C. Dong, K. Niu, H. Liang, Z. Liang, X. Qin, M. Sun, H. Chen, N. Ma, et al., Model division multiple access for semantic communications, *Frontiers of Information Technology & Electronic Engineering* 24 (6) (2023) 801–812.
- [11] C. Chaccour, W. Saad, M. Debbah, Z. Han, H. V. Poor, Less data, more knowledge: Building next generation semantic communication networks, *IEEE Communications Surveys & Tutorials* (2024).
- [12] C. Liang, H. Du, Y. Sun, D. Niyato, J. Kang, D. Zhao, M. A. Imran, Generative ai-driven semantic communication networks: Architecture, technologies and applications, *IEEE Transactions on Cognitive Communications and Networking* (2024).
- [13] J. Xu, T.-Y. Tung, B. Ai, W. Chen, Y. Sun, D. Gündüz, Deep joint source-channel coding for semantic communications, *IEEE Communications Magazine* 61 (11) (2023) 42–48.

- [14] M. Nemati, J. Park, J. Choi, Vq-vae empowered wireless communication for joint source-channel coding and beyond, in: GLOBECOM 2023 - 2023 IEEE Global Communications Conference, 2023, pp. 3155–3160.
- [15] H. Wu, Y. Shao, C. Bian, K. Mikolajczyk, D. Gündüz, Deep joint source-channel coding for adaptive image transmission over mimo channels, *IEEE Transactions on Wireless Communications* 23 (10) (2024) 15002–15017.
- [16] J. Huang, D. Li, C. Huang, X. Qin, W. Zhang, Joint task and data-oriented semantic communications: A deep separate source-channel coding scheme, *IEEE Internet of Things Journal* 11 (2) (2024) 2255–2272.
- [17] Y. Wang, S. Han, X. Xu, H. Liang, R. Meng, C. Dong, P. Zhang, Feature importance-aware task-oriented semantic transmission and optimization, *IEEE Transactions on Cognitive Communications and Networking* (2024).
- [18] M. U. Lokumarambage, V. S. S. Gowrisetty, H. Rezaei, T. Sivalingam, N. Rajatheva, A. Fernando, Wireless end-to-end image transmission system using semantic communications, *IEEE Access* 11 (2023) 37149–37163.
- [19] S. Wang, J. Dai, Z. Liang, K. Niu, Z. Si, C. Dong, X. Qin, P. Zhang, Wireless deep video semantic transmission, *IEEE Journal on Selected Areas in Communications* 41 (1) (2022) 214–229.
- [20] S. Yao, K. Niu, S. Wang, J. Dai, Semantic coding for text transmission: An iterative design, *IEEE Transactions on Cognitive Communications and Networking* 8 (4) (2022) 1594–1603.
- [21] T. Han, Q. Yang, Z. Shi, S. He, Z. Zhang, Semantic-preserved communication system for highly efficient speech transmission, *IEEE Journal on Selected Areas in Communications* 41 (1) (2023) 245–259.
- [22] M. Shen, J. Wang, H. Du, D. Niyato, X. Tang, J. Kang, Y. Ding, L. Zhu, Secure semantic communications: Challenges, approaches, and opportunities, *IEEE Network* (2023).

- [23] Z. Yang, M. Chen, G. Li, Y. Yang, Z. Zhang, Secure semantic communications: Fundamentals and challenges, *IEEE Network* (2024).
- [24] S. Guo, Y. Wang, N. Zhang, Z. Su, T. H. Luan, Z. Tian, X. Shen, A survey on semantic communication networks: Architecture, security, and privacy, *arXiv preprint arXiv:2405.01221* (2024).
- [25] H. Du, J. Wang, D. Niyato, J. Kang, Z. Xiong, M. Guizani, D. I. Kim, Rethinking wireless communication security in semantic internet of things, *IEEE Wireless Communications* 30 (3) (2023) 36–43.
- [26] Y. Chen, Q. Yang, Z. Shi, J. Chen, The model inversion eavesdropping attack in semantic communication systems, in: *GLOBECOM 2023-2023 IEEE Global Communications Conference*, IEEE, 2023, pp. 5171–5177.
- [27] Y. Wang, S. Guo, Y. Deng, H. Zhang, Y. Fang, Privacy-preserving task-oriented semantic communications against model inversion attacks, *IEEE Transactions on Wireless Communications* (2024).
- [28] T.-Y. Tung, D. Gündüz, Deep joint source-channel and encryption coding: Secure semantic communications, in: *ICC 2023 - IEEE International Conference on Communications*, 2023, pp. 5620–5625. doi:10.1109/ICC45041.2023.10278612.
- [29] X. Luo, Z. Chen, M. Tao, F. Yang, Encrypted semantic communication using adversarial training for privacy preserving, *IEEE Communications Letters* 27 (6) (2023) 1486–1490. doi:10.1109/LCOMM.2023.3269768.
- [30] Y. Chen, Q. Yang, Z. Shi, J. Chen, The model inversion eavesdropping attack in semantic communication systems, in: *GLOBECOM 2023 - 2023 IEEE Global Communications Conference*, 2023, pp. 5171–5177. doi:10.1109/GLOBECOM54140.2023.10436996.
- [31] G. Chen, G. Nan, Z. Jiang, H. Du, R. Shi, Q. Cui, X. Tao, Lightweight and robust wireless semantic communications, *IEEE Communications Letters* (2024) 1–1doi:10.1109/LCOMM.2024.3409559.



- [32] Y. Li, Z. Shi, H. Hu, Y. Fu, H. Wang, H. Lei, Secure semantic communications: From perspective of physical layer security, *IEEE Communications Letters* 28 (10) (2024) 2243–2247. doi:10.1109/LCOMM.2024.3452715.
- [33] X. Mu, Y. Liu, Semantic communication-assisted physical layer security over fading wiretap channels (2024). arXiv:2402.14581. URL <https://arxiv.org/abs/2402.14581>
- [34] Y. Liu, J. Wen, Z. Zhang, K. Zhu, J. Kang, Learning-based power control for secure covert semantic communication (2024). arXiv:2407.07475. URL <https://arxiv.org/abs/2407.07475>
- [35] Q. Qin, Y. Rong, G. Nan, S. Wu, X. Zhang, Q. Cui, X. Tao, Securing semantic communications with physical-layer semantic encryption and obfuscation, in: *ICC 2023 - IEEE International Conference on Communications, 2023*, pp. 5608–5613. doi:10.1109/ICC45041.2023.10279807.
- [36] S. Tang, C. Liu, Q. Yang, S. He, D. Niyato, Secure semantic communication for image transmission in the presence of eavesdroppers, arXiv preprint arXiv:2404.12170 (2024).
- [37] R. Xu, G. Li, Z. Yang, M. Chen, Y. Liu, J. Li, Covert and reliable semantic communication against cross-layer privacy inference over wireless edge networks, in: *2024 IEEE Wireless Communications and Networking Conference (WCNC), 2024*, pp. 1–6. doi:10.1109/WCNC57260.2024.10570800.
- [38] D. Won, G. Woraphonbenjakul, A. B. Wondmagegn, A. T. Tran, D. Lee, D. S. Lakew, S. Cho, Resource management, security, and privacy issues in semantic communications: A survey, *IEEE Communications Surveys & Tutorials* (2024).
- [39] Y. E. Sagduyu, T. Erpek, S. Ulukus, A. Yener, Is semantic communication secure? a tale of multi-domain adversarial attacks, *IEEE Communications Magazine* 61 (11) (2023) 50–55. doi:10.1109/MCOM.006.2200878.

- [40] H. Du, J. Wang, D. Niyato, J. Kang, Z. Xiong, M. Guizani, D. I. Kim, Rethinking wireless communication security in semantic internet of things, *IEEE Wireless Communications* 30 (3) (2023) 36–43. doi:10.1109/MWC.011.2200547.
- [41] M. Shen, J. Wang, H. Du, D. Niyato, X. Tang, J. Kang, Y. Ding, L. Zhu, Secure semantic communications: Challenges, approaches, and opportunities, *IEEE Network* 38 (4) (2024) 197–206. doi:10.1109/MNET.2023.3327111.
- [42] Z. Yang, M. Chen, G. Li, Y. Yang, Z. Zhang, Secure semantic communications: Fundamentals and challenges, *IEEE Network* (2024) 1–1doi:10.1109/MNET.2024.3411027.
- [43] X. Luo, H.-H. Chen, Q. Guo, Semantic communications: Overview, open issues, and future research directions, *IEEE Wireless Communications* 29 (1) (2022) 210–219. doi:10.1109/MWC.101.2100269.
- [44] J. He, X. Luo, J. Kang, H. Du, Z. Xiong, C. Chen, D. Niyato, X. Shen, Toward mixture-of-experts enabled trustworthy semantic communication for 6g networks (2024). arXiv:2409.15695.  
URL <https://arxiv.org/abs/2409.15695>
- [45] P. Zhang, X. Xu, C. Dong, S. Han, B. Wang, Intellicise communication system: model-driven semantic communications, *The Journal of China Universities of Posts and Telecommunications* 29 (1) (2022) 11.
- [46] Z. Wang, B. Lin, L. Sun, Y. Wang, Intelligent task offloading for 6g-enabled maritime iot based on reinforcement learning, in: 2021 International Conference on Security, Pattern Analysis, and Cybernetics (SPAC), 2021, pp. 566–570.
- [47] G. Shi, Y. Xiao, Y. Li, D. Gao, X. Xie, Semantic communication networking for the intelligence of everything, *Chinese Journal on Internet of Things* 5 (2021) 26–36.
- [48] G. Shi, Y. Li, X. Xie, Semantic communications: Outcome of the intelligence era, *Pattern Recognition and Artificial Intelligence* 31 (2018) 91–99.

- [49] C. Liu, C. Guo, Y. Yang, C. Feng, Q. Sun, J. Chen, Intelligent task-oriented semantic communication method in artificial intelligence of things, *Journal on Communications* 11 (2021) 97–108.
- [50] W. Yining, H. Shujun, X. Xiaodong, M. Rui, L. Haotai, D. Chen, Z. Ping, Intellicise model transmission for semantic communication in intelligence-native 6g networks, *China Communications* 21 (7) (2024) 95–112.
- [51] W. Fedus, B. Zoph, N. Shazeer, Switch transformers: Scaling to trillion parameter models with simple and efficient sparsity, *Journal of Machine Learning Research* 23 (120) (2022) 1–39.
- [52] F. Fui-Hoon Nah, R. Zheng, J. Cai, K. Siau, L. Chen, Generative ai and chatgpt: Applications, challenges, and ai-human collaboration (2023).
- [53] H. Chen, S. Chen, C. He, H. Li, A scalable semantic communication system based on meta-learning, in: *2024 International Wireless Communications and Mobile Computing (IWCMC)*, IEEE, 2024, pp. 561–566.
- [54] Q. Wu, F. Liu, H. Xia, T. Zhang, Semantic transfer between different tasks in the semantic communication system, in: *2022 IEEE Wireless Communications and Networking Conference (WCNC)*, IEEE, 2022, pp. 566–571.
- [55] C. Liu, Y. Zhou, Y. Chen, S.-H. Yang, Knowledge distillation based semantic communications for multiple users, *IEEE Transactions on Wireless Communications* (2023).
- [56] D. Li, J. Wang, Fedmd: Heterogenous federated learning via model distillation, *arXiv preprint arXiv:1910.03581* (2019).
- [57] Y. Wang, W. Ni, W. Yi, X. Xu, P. Zhang, A. Nallanathan, Federated contrastive learning for personalized semantic communication, *IEEE Communications Letters* 28 (8) (2024) 1875–1879. doi:10.1109/LCOMM.2024.3415431.
- [58] L. X. Nguyen, H. Q. Le, Y. L. Tun, P. S. Aung, Y. K. Tun, Z. Han, C. S. Hong, An efficient federated learning framework for training semantic

communication systems, *IEEE Transactions on Vehicular Technology* (2024).

- [59] H. Sun, S. Li, F. R. Yu, Q. Qi, J. Wang, J. Liao, Toward communication-efficient federated learning in the internet of things with edge computing, *IEEE Internet of Things Journal* 7 (11) (2020) 11053–11067.
- [60] X. Cao, T. Başar, S. Diggavi, Y. C. Eldar, K. B. Letaief, H. V. Poor, J. Zhang, Communication-efficient distributed learning: An overview, *IEEE journal on selected areas in communications* 41 (4) (2023) 851–873.
- [61] C. Dong, H. Liang, X. Xu, S. Han, B. Wang, P. Zhang, Semantic communication system based on semantic slice models propagation, *IEEE Journal on Selected Areas in Communications* 41 (1) (2022) 202–213.
- [62] Z. Li, H. Li, L. Meng, Model compression for deep neural networks: A survey, *Computers* 12 (3) (2023).
- [63] P. Qi, D. Chiaro, A. Guzzo, M. Ianni, G. Fortino, F. Piccialli, Model aggregation techniques in federated learning: A comprehensive survey, *Future Generation Computer Systems* 150 (2024) 272–293.
- [64] D. Wheeler, B. Natarajan, Engineering semantic communication: A survey, *IEEE Access* 11 (2023) 13965–13995.
- [65] Y. Liu, X. Wang, Z. Ning, M. Zhou, L. Guo, B. Jedari, A survey on semantic communications: technologies, solutions, applications and challenges, *Digital Communications and Networks* (2023).
- [66] S. Samonas, D. Coss, The cia strikes back: Redefining confidentiality, integrity and availability in security., *Journal of Information System Security* 10 (3) (2014).
- [67] S. Dilmaghani, M. R. Brust, G. Danoy, N. Cassagnes, J. Pecero, P. Bouvry, Privacy and security of big data in ai systems: A research and standards perspective, in: *2019 IEEE International Conference on Big Data (Big Data)*, IEEE, 2019, pp. 5737–5743.

- [68] L. Sweeney, Simple demographics often identify people uniquely, *Health (San Francisco)* 671 (2000) (2000) 1–34.
- [69] R. Shokri, M. Stronati, C. Song, V. Shmatikov, Membership inference attacks against machine learning models, in: *2017 IEEE Symposium on Security and Privacy (SP)*, 2017, pp. 3–18.
- [70] K. Ganju, Q. Wang, W. Yang, C. A. Gunter, N. Borisov, Property inference attacks on fully connected neural networks using permutation invariant representations, in: *Proceedings of the 2018 ACM SIGSAC Conference on Computer and Communications Security*, 2018, p. 619–633.
- [71] F. Tramèr, F. Zhang, A. Juels, M. K. Reiter, T. Ristenpart, Stealing machine learning models via prediction apis, in: *Proceedings of the 25th USENIX Conference on Security Symposium, SEC’16*, USENIX Association, USA, 2016, p. 601–618.
- [72] S. J. Oh, M. Augustin, M. Fritz, B. Schiele, Towards reverse-engineering black-box neural networks, in: *ICLR*, 2018.
- [73] K. Eykholt, I. Evtimov, E. Fernandes, B. Li, A. Rahmati, C. Xiao, A. Prakash, T. Kohno, D. Song, Robust physical-world attacks on deep learning visual classification, in: *Proceedings of the IEEE conference on computer vision and pattern recognition*, 2018, pp. 1625–1634.
- [74] S.-M. Moosavi-Dezfooli, A. Fawzi, P. Frossard, Deepfool: a simple and accurate method to fool deep neural networks, in: *Proceedings of the IEEE conference on computer vision and pattern recognition*, 2016, pp. 2574–2582.
- [75] B. Biggio, K. Rieck, D. Ariu, C. Wressnegger, I. Corona, G. Giacinto, F. Roli, Poisoning behavioral malware clustering, in: *Proceedings of the 2014 workshop on artificial intelligent and security workshop*, 2014, pp. 27–36.
- [76] A. Newell, R. Potharaju, L. Xiang, C. Nita-Rotaru, On the practicality of integrity attacks on document-level sentiment analysis, in: *Proceedings of the 2014 Workshop on Artificial Intelligent and Security Workshop*, 2014, pp. 83–93.

- [77] J. H. Hinnefeld, P. Cooman, N. Mammo, R. Deese, Evaluating fairness metrics in the presence of dataset bias, arXiv preprint arXiv:1809.09245 (2018).
- [78] L. Fowl, J. Geiping, W. Czaja, M. Goldblum, T. Goldstein, Robbing the fed: Directly obtaining private data in federated learning with modified models, arXiv preprint arXiv:2110.13057 (2021).
- [79] Z. Wang, J. Wang, D. Shi, X. Duan, Impact identification and assessment of cyber contingencies on measurement availability of power systems, IET Generation, Transmission, and Distribution (2022).
- [80] M. Khodak, M.-F. F. Balcan, A. S. Talwalkar, Adaptive gradient-based meta-learning methods, Advances in Neural Information Processing Systems 32 (2019).
- [81] Y. Zhao, M. Li, L. Lai, N. Suda, D. Civin, V. Chandra, Federated learning with non-iid data, arXiv preprint arXiv:1806.00582 (2018).
- [82] G. Hinton, O. Vinyals, J. Dean, et al., Distilling the knowledge in a neural network, arXiv preprint arXiv:1503.02531 2 (7) (2015).
- [83] B. McMahan, E. Moore, D. Ramage, S. Hampson, B. A. y. Arcas, Communication-Efficient Learning of Deep Networks from Decentralized Data, in: A. Singh, J. Zhu (Eds.), Proceedings of the 20th International Conference on Artificial Intelligence and Statistics, Vol. 54 of Proceedings of Machine Learning Research, PMLR, 2017, pp. 1273–1282.
- [84] Y. Sun, J. Liu, J. Wang, Y. Cao, N. Kato, When machine learning meets privacy in 6g: A survey, IEEE Communications Surveys Tutorials 22 (4) (2020) 2694–2724.
- [85] V. Mothukuri, R. M. Parizi, S. Pouriye, Y. Huang, A. Dehghantaha, G. Srivastava, A survey on security and privacy of federated learning, Future Generation Computer Systems 115 (2021) 619–640.
- [86] D. Cao, S. Chang, Z. Lin, G. Liu, D. Sun, Understanding distributed poisoning attack in federated learning, in: 2019 IEEE 25th International Conference on Parallel and Distributed Systems (ICPADS), IEEE, 2019, pp. 233–239.

- [87] A. N. Bhagoji, S. Chakraborty, P. Mittal, S. Calo, Analyzing federated learning through an adversarial lens, in: International Conference on Machine Learning, PMLR, 2019, pp. 634–643.
- [88] P. Blanchard, E. M. El Mhamdi, R. Guerraoui, J. Stainer, Machine learning with adversaries: Byzantine tolerant gradient descent, *Advances in Neural Information Processing Systems* 30 (2017).
- [89] J. Kang, Z. Xiong, C. Jiang, Y. Liu, S. Guo, Y. Zhang, D. Niyato, C. Leung, C. Miao, Scalable and communication-efficient decentralized federated edge learning with multi-blockchain framework, in: International Conference on Blockchain and Trustworthy Systems, Springer, 2020, pp. 152–165.
- [90] T. Gu, K. Liu, B. Dolan-Gavitt, S. Garg, Badnets: Evaluating backdooring attacks on deep neural networks, *IEEE Access* 7 (2019) 47230–47244.
- [91] E. Bagdasaryan, A. Veit, Y. Hua, D. Estrin, V. Shmatikov, How to backdoor federated learning, in: International Conference on Artificial Intelligence and Statistics, PMLR, 2020, pp. 2938–2948.
- [92] M. Fang, X. Cao, J. Jia, N. Gong, Local model poisoning attacks to {Byzantine-Robust} federated learning, in: 29th USENIX Security Symposium (USENIX Security 20), 2020, pp. 1605–1622.
- [93] C. Xie, K. Huang, P.-Y. Chen, B. Li, Dba: Distributed backdoor attacks against federated learning, in: International Conference on Learning Representations, 2019.
- [94] L. Zhu, Z. Liu, S. Han, Deep leakage from gradients, *Advances in Neural Information Processing Systems* 32 (2019).
- [95] B. Zhao, K. R. Mopuri, H. Bilin, idlg: Improved deep leakage from gradients, *arXiv preprint arXiv:2001.02610* (2020).
- [96] H. Yin, A. Mallya, A. Vahdat, J. M. Alvarez, J. Kautz, P. Molchanov, See through gradients: Image batch recovery via gradinversion, in: Proceedings of the IEEE/CVF Conference on Computer Vision and Pattern Recognition, 2021, pp. 16337–16346.

- [97] Z. Liu, J. Guo, W. Yang, J. Fan, K.-Y. Lam, J. Zhao, Privacy-preserving aggregation in federated learning: A survey, *IEEE Transactions on Big Data* (2022).
- [98] J. F. Shoch, Packet fragmentation in inter-network protocols, *Computer Networks* (1976) 3 (1) (1979) 3–8.
- [99] R. Bommasani, D. A. Hudson, E. Adeli, R. Altman, S. Arora, S. von Arx, M. S. Bernstein, J. Bohg, A. Bosselut, E. Brunskill, et al., On the opportunities and risks of foundation models, *arXiv preprint arXiv:2108.07258* (2021).
- [100] A. Vaswani, N. Shazeer, N. Parmar, J. Uszkoreit, L. Jones, A. N. Gomez, L. Kaiser, I. Polosukhin, Attention is all you need, in: *Proceedings of the 31st International Conference on Neural Information Processing Systems, NIPS'17*, Curran Associates Inc., Red Hook, NY, USA, 2017, p. 6000–6010.
- [101] J. Devlin, M.-W. Chang, K. Lee, K. Toutanova, Bert: Pre-training of deep bidirectional transformers for language understanding, *arXiv preprint arXiv:1810.04805* (2018).
- [102] T. Brown, B. Mann, N. Ryder, M. Subbiah, J. D. Kaplan, P. Dhariwal, A. Neelakantan, P. Shyam, G. Sastry, A. Askell, et al., Language models are few-shot learners, *Advances in neural information processing systems* 33 (2020) 1877–1901.
- [103] W. ZENG, T. SU, H. WANG, Y. TIAN, W. GAO, Pengcheng-pangu: Large-scale autoregressive pre-trained chinese language model with auto-parallel computation and its application, *ZTE technology* (2022).
- [104] W. Fedus, B. Zoph, N. Shazeer, Switch transformers: Scaling to trillion parameter models with simple and efficient sparsity, *Journal of Machine Learning Research* 23 (120) (2022) 1–39.  
URL <http://jmlr.org/papers/v23/21-0998.html>
- [105] S. Sun, W. Chen, J. Bian, X. Liu, T.-Y. Liu, Slim-dp: a multi-agent system for communication-efficient distributed deep learning, in: *Proceedings of the 17th International Conference on Autonomous Agents and MultiAgent Systems*, 2018, pp. 721–729.



- [106] H. Li, C. Hu, J. Jiang, Z. Wang, Y. Wen, W. Zhu, Jalad: Joint accuracy-and latency-aware deep structure decoupling for edge-cloud execution, in: 2018 IEEE 24th international conference on parallel and distributed systems (ICPADS), IEEE, 2018, pp. 671–678.
- [107] S. Teerapittayanon, B. McDanel, H.-T. Kung, Branchynet: Fast inference via early exiting from deep neural networks, in: 2016 23rd International Conference on Pattern Recognition (ICPR), IEEE, 2016, pp. 2464–2469.
- [108] X. Tang, X. Chen, L. Zeng, S. Yu, L. Chen, Joint multiuser dnn partitioning and computational resource allocation for collaborative edge intelligence, *IEEE Internet of Things Journal* 8 (12) (2020) 9511–9522.
- [109] D. Sattar, A. Matrawy, Towards secure slicing: Using slice isolation to mitigate ddos attacks on 5g core network slices, in: 2019 IEEE Conference on Communications and Network Security (CNS), IEEE, 2019, pp. 82–90.
- [110] A. A. Mughal, Cybersecurity architecture for the cloud: Protecting network in a virtual environment, *International Journal of Intelligent Automation and Computing* 4 (1) (2021) 35–48.
- [111] M. Bellare, S. Tessaro, A. Vardy, Semantic security for the wiretap channel, in: Annual Cryptology Conference, Springer, 2012, pp. 294–311.
- [112] S. Huang, N. Papernot, I. Goodfellow, Y. Duan, P. Abbeel, Adversarial attacks on neural network policies, arXiv preprint arXiv:1702.02284 (2017).
- [113] X. Luo, H.-H. Chen, Q. Guo, Semantic communications: Overview, open issues, and future research directions, *IEEE Wireless Communications* 29 (1) (2022) 210–219.
- [114] R. Meng, H. Zhao, B. Xu, Y. Wang, X. Xu, S. Lv, X. Tao, P. Zhang, TdgcN-based mobile multiuser physical-layer authentication for ei-enabled iiot, arXiv preprint arXiv:2411.08628 (2024).

- [115] H. Pirayesh, H. Zeng, Jamming attacks and anti-jamming strategies in wireless networks: A comprehensive survey, *IEEE communications surveys & tutorials* 24 (2) (2022) 767–809.
- [116] R. Tang, D. Gao, M. Yang, T. Guo, H. Wu, G. Shi, Gan-inspired intelligent jamming and anti-jamming strategy for semantic communication systems, in: *2023 IEEE International Conference on Communications Workshops (ICC Workshops)*, IEEE, 2023, pp. 1623–1628.
- [117] P. Li, X. Rao, J. Blase, Y. Zhang, X. Chu, C. Zhang, Cleanml: A study for evaluating the impact of data cleaning on ml classification tasks, in: *2021 IEEE 37th International Conference on Data Engineering (ICDE)*, IEEE, 2021, pp. 13–24.
- [118] S. E. Whang, J.-G. Lee, Data collection and quality challenges for deep learning, *Proceedings of the VLDB Endowment* 13 (12) (2020) 3429–3432.
- [119] A. Rajan, *Data cleaning for machine learning systems-a survey* (2024).
- [120] X. Chu, I. F. Ilyas, S. Krishnan, J. Wang, Data cleaning: Overview and emerging challenges, in: *Proceedings of the 2016 international conference on management of data*, 2016, pp. 2201–2206.
- [121] G. Y. Lee, L. Alzamil, B. Doskenov, A. Termehchy, A survey on data cleaning methods for improved machine learning model performance, *arXiv preprint arXiv:2109.07127* (2021).
- [122] S. Tang, S. Yuan, Y. Zhu, Data preprocessing techniques in convolutional neural network based on fault diagnosis towards rotating machinery, *IEEE Access* 8 (2020) 149487–149496.
- [123] K. H. Tae, Y. Roh, Y. H. Oh, H. Kim, S. E. Whang, Data cleaning for accurate, fair, and robust models: A big data-ai integration approach, in: *Proceedings of the 3rd international workshop on data management for end-to-end machine learning*, 2019, pp. 1–4.
- [124] X. Zhang, F. Li, Z. Zhang, Q. Li, C. Wang, J. Wu, Enabling execution assurance of federated learning at untrusted participants, in: *IEEE INFOCOM 2020-IEEE Conference on Computer Communications*, IEEE, 2020, pp. 1877–1886.

- [125] K. Pillutla, S. M. Kakade, Z. Harchaoui, Robust aggregation for federated learning, *IEEE Transactions on Signal Processing* 70 (2022) 1142–1154.
- [126] A. Ghosh, J. Hong, D. Yin, K. Ramchandran, Robust federated learning in a heterogeneous environment, *arXiv preprint arXiv:1906.06629* (2019).
- [127] X. Fang, M. Ye, Robust federated learning with noisy and heterogeneous clients, in: *Proceedings of the IEEE/CVF Conference on Computer Vision and Pattern Recognition*, 2022, pp. 10072–10081.
- [128] L. Lyu, H. Yu, X. Ma, C. Chen, L. Sun, J. Zhao, Q. Yang, S. Y. Philip, Privacy and robustness in federated learning: Attacks and defenses, *IEEE transactions on neural networks and learning systems* (2022).
- [129] F. Sattler, S. Wiedemann, K.-R. Müller, W. Samek, Robust and communication-efficient federated learning from non-iid data, *IEEE transactions on neural networks and learning systems* 31 (9) (2019) 3400–3413.
- [130] F. Ang, L. Chen, N. Zhao, Y. Chen, W. Wang, F. R. Yu, Robust federated learning with noisy communication, *IEEE Transactions on Communications* 68 (6) (2020) 3452–3464.
- [131] Q. Jiang, M. Li, Y. Sun, Overview of deep neural network backdoor defense, *Journal of Cyber Security* 9 (4) (2024).
- [132] B. Tran, J. Li, A. Madry, Spectral signatures in backdoor attacks, *Advances in neural information processing systems* 31 (2018).
- [133] J. Hayase, W. Kong, R. Somani, S. Oh, Spectre: Defending against backdoor attacks using robust statistics, in: *International Conference on Machine Learning*, PMLR, 2021, pp. 4129–4139.
- [134] B. Chen, W. Carvalho, N. Baracaldo, H. Ludwig, B. Edwards, T. Lee, I. Molloy, B. Srivastava, Detecting backdoor attacks on deep neural networks by activation clustering, *arXiv preprint arXiv:1811.03728* (2018).
- [135] L. Schulth, C. Berghoff, M. Neu, Detecting backdoor poisoning attacks on deep neural networks by heatmap clustering, *arXiv preprint arXiv:2204.12848* (2022).

- [136] A. Chan, Y.-S. Ong, Poison as a cure: Detecting & neutralizing variable-sized backdoor attacks in deep neural networks, arXiv preprint arXiv:1911.08040 (2019).
- [137] J. Geiping, L. Fowl, G. Somepalli, M. Goldblum, M. Moeller, T. Goldstein, What doesn't kill you makes you robust (er): How to adversarially train against data poisoning, arXiv preprint arXiv:2102.13624 (2021).
- [138] S. Hong, V. Chandrasekaran, Y. Kaya, T. Dumitras, N. Papernot, On the effectiveness of mitigating data poisoning attacks with gradient shaping, arXiv preprint arXiv:2002.11497 (2020).
- [139] Y. Gao, C. Xu, D. Wang, S. Chen, D. C. Ranasinghe, S. Nepal, Strip: A defence against trojan attacks on deep neural networks, in: Proceedings of the 35th annual computer security applications conference, 2019, pp. 113–125.
- [140] M. Subedar, N. Ahuja, R. Krishnan, I. J. Ndiour, O. Tickoo, Deep probabilistic models to detect data poisoning attacks, arXiv preprint arXiv:1912.01206 (2019).
- [141] Y. Liu, Y. Xie, A. Srivastava, Neural trojans, in: 2017 IEEE International Conference on Computer Design (ICCD), IEEE, 2017, pp. 45–48.
- [142] H. Qiu, Y. Zeng, S. Guo, T. Zhang, M. Qiu, B. Thuraisingham, Deep-sweep: An evaluation framework for mitigating dnn backdoor attacks using data augmentation, in: Proceedings of the 2021 ACM Asia Conference on Computer and Communications Security, 2021, pp. 363–377.
- [143] B. Wang, Y. Yao, S. Shan, H. Li, B. Viswanath, H. Zheng, B. Y. Zhao, Neural cleanse: Identifying and mitigating backdoor attacks in neural networks, in: 2019 IEEE symposium on security and privacy (SP), IEEE, 2019, pp. 707–723.
- [144] L. Zhu, R. Ning, C. Wang, C. Xin, H. Wu, Gangsweep: Sweep out neural backdoors by gan, in: Proceedings of the 28th ACM International Conference on Multimedia, 2020, pp. 3173–3181.

- [145] S. Huang, W. Peng, Z. Jia, Z. Tu, One-pixel signature: Characterizing cnn models for backdoor detection, in: *Computer Vision–ECCV 2020: 16th European Conference, Glasgow, UK, August 23–28, 2020, Proceedings, Part XXVII 16*, Springer, 2020, pp. 326–341.
- [146] K. Liu, B. Dolan-Gavitt, S. Garg, Fine-pruning: Defending against backdooring attacks on deep neural networks, in: *International symposium on research in attacks, intrusions, and defenses*, Springer, 2018, pp. 273–294.
- [147] D. Wu, Y. Wang, Adversarial neuron pruning purifies backdoored deep models, *Advances in Neural Information Processing Systems* 34 (2021) 16913–16925.
- [148] Y. Zhou, R. Q. Hu, Y. Qian, Backdoor attacks and defenses on semantic-symbol reconstruction in semantic communications, *arXiv preprint arXiv:2404.13279* (2024).
- [149] W. Zhao, S. Alwidian, Q. H. Mahmoud, Adversarial training methods for deep learning: A systematic review, *Algorithms* 15 (8) (2022) 283.
- [150] I. J. Goodfellow, J. Shlens, C. Szegedy, Explaining and harnessing adversarial examples, *arXiv preprint arXiv:1412.6572* (2014).
- [151] Q. Hu, G. Zhang, Z. Qin, Y. Cai, G. Yu, G. Y. Li, Robust semantic communications against semantic noise, in: *2022 IEEE 96th Vehicular Technology Conference (VTC2022-Fall)*, IEEE, 2022, pp. 1–6.
- [152] J. Kang, J. He, H. Du, Z. Xiong, Z. Yang, X. Huang, S. Xie, Adversarial attacks and defenses for semantic communication in vehicular metaverses, *IEEE Wireless Communications* 30 (4) (2023) 48–55.
- [153] G. Nan, Z. Li, J. Zhai, Q. Cui, G. Chen, X. Du, X. Zhang, X. Tao, Z. Han, T. Q. Quek, Physical-layer adversarial robustness for deep learning-based semantic communications, *IEEE Journal on Selected Areas in Communications* 41 (8) (2023) 2592–2608.
- [154] X. Luo, Z. Chen, M. Tao, F. Yang, Encrypted semantic communication using adversarial training for privacy preserving, *IEEE Communications Letters* 27 (6) (2023) 1486–1490.

- [155] Y. Wang, D. Zou, J. Yi, J. Bailey, X. Ma, Q. Gu, Improving adversarial robustness requires revisiting misclassified examples, in: International conference on learning representations, 2019.
- [156] H. Zhang, Y. Yu, J. Jiao, E. Xing, L. El Ghaoui, M. Jordan, Theoretically principled trade-off between robustness and accuracy, in: International conference on machine learning, PMLR, 2019, pp. 7472–7482.
- [157] G. W. Ding, Y. Sharma, K. Y. C. Lui, R. Huang, Mma training: Direct input space margin maximization through adversarial training, arXiv preprint arXiv:1812.02637 (2018).
- [158] M. Cheng, Q. Lei, P.-Y. Chen, I. Dhillon, C.-J. Hsieh, Cat: Customized adversarial training for improved robustness, arXiv preprint arXiv:2002.06789 (2020).
- [159] B. He, F. Wang, T. Q. Quek, Secure semantic communication via paired adversarial residual networks, *IEEE Wireless Communications Letters* (2024).
- [160] C. Dwork, Differential privacy: A survey of results, in: International conference on theory and applications of models of computation, Springer, 2008, pp. 1–19.
- [161] P. Jain, M. Gyanchandani, N. Khare, Differential privacy: its technological prescriptive using big data, *Journal of Big Data* 5 (1) (2018) 1–24.
- [162] J. Zhao, Y. Chen, W. Zhang, Differential privacy preservation in deep learning: Challenges, opportunities and solutions, *IEEE Access* 7 (2019) 48901–48911.
- [163] R. Shokri, V. Shmatikov, Privacy-preserving deep learning, in: Proceedings of the 22nd ACM SIGSAC conference on computer and communications security, 2015, pp. 1310–1321.
- [164] K. Wei, J. Li, M. Ding, C. Ma, H. H. Yang, F. Farokhi, S. Jin, T. Q. Quek, H. V. Poor, Federated learning with differential privacy: Algorithms and performance analysis, *IEEE Transactions on Information Forensics and Security* 15 (2020) 3454–3469.

- [165] B. Hitaj, G. Ateniese, F. Perez-Cruz, Deep models under the gan: Information leakage from collaborative deep learning, in: Proceedings of the 2017 ACM SIGSAC Conference on Computer and Communications Security, CCS '17, Association for Computing Machinery, New York, NY, USA, 2017, p. 603–618.
- [166] Z. Wang, M. Song, Z. Zhang, Y. Song, Q. Wang, H. Qi, Beyond inferring class representatives: User-level privacy leakage from federated learning, in: IEEE INFOCOM 2019 - IEEE Conference on Computer Communications, 2019, pp. 2512–2520.
- [167] S. Song, K. Chaudhuri, A. D. Sarwate, Stochastic gradient descent with differentially private updates, in: 2013 IEEE global conference on signal and information processing, IEEE, 2013, pp. 245–248.
- [168] M. Abadi, A. Chu, I. Goodfellow, H. B. McMahan, I. Mironov, K. Talwar, L. Zhang, Deep learning with differential privacy, in: Proceedings of the 2016 ACM SIGSAC conference on computer and communications security, 2016, pp. 308–318.
- [169] H. Liu, B. Wang, R. Meng, S. Han, X. Xu, Adaptive privacy budget-based differential privacy co-training for wireless semantic communication, in: 2024 IEEE Wireless Communications and Networking Conference (WCNC), IEEE, 2024, pp. 1–6.
- [170] K. Chaudhuri, C. Monteleoni, A. D. Sarwate, Differentially private empirical risk minimization., *Journal of Machine Learning Research* 12 (3) (2011).
- [171] M. Winslett, J. Zhang, Z. Zhang, X. Xiao, Y. Yang, Functional mechanism: regression analysis under differential privacy, *Proceedings of the VLDB Endowment* (2012).
- [172] N. Phan, Y. Wang, X. Wu, D. Dou, Differential privacy preservation for deep auto-encoders: an application of human behavior prediction, in: *Proceedings of the AAAI Conference on Artificial Intelligence*, Vol. 30, 2016.
- [173] N. Phan, X. Wu, H. Hu, D. Dou, Adaptive laplace mechanism: Differential privacy preservation in deep learning, in: 2017 IEEE international conference on data mining (ICDM), IEEE, 2017, pp. 385–394.

- [174] G. Acs, L. Melis, C. Castelluccia, E. De Cristofaro, Differentially private mixture of generative neural networks, *IEEE Transactions on Knowledge and Data Engineering* 31 (6) (2018) 1109–1121.
- [175] X. Zhang, S. Ji, T. Wang, Differentially private releasing via deep generative model (technical report), arXiv preprint arXiv:1801.01594 (2018).
- [176] W. Chen, S. Tang, Q. Yang, Enhancing image privacy in semantic communication over wiretap channels leveraging differential privacy, arXiv preprint arXiv:2405.09234 (2024).
- [177] G. Cormode, C. Procopiuc, D. Srivastava, E. Shen, T. Yu, Differentially private spatial decompositions, in: 2012 IEEE 28th International Conference on Data Engineering, IEEE, 2012, pp. 20–31.
- [178] H. Li, L. Xiong, X. Jiang, J. Liu, Differentially private histogram publication for dynamic datasets: an adaptive sampling approach, in: Proceedings of the 24th ACM international on conference on information and knowledge management, 2015, pp. 1001–1010.
- [179] C. Gentry, Fully homomorphic encryption using ideal lattices, in: Proceedings of the forty-first annual ACM symposium on Theory of computing, 2009, pp. 169–178.
- [180] Y. Aono, T. Hayashi, L. Wang, S. Moriai, et al., Privacy-preserving deep learning via additively homomorphic encryption, *IEEE transactions on information forensics and security* 13 (5) (2017) 1333–1345.
- [181] H. Fang, Q. Qian, Privacy preserving machine learning with homomorphic encryption and federated learning, *Future Internet* 13 (4) (2021) 94.
- [182] J.-W. Lee, H. Kang, Y. Lee, W. Choi, J. Eom, M. Deryabin, E. Lee, J. Lee, D. Yoo, Y.-S. Kim, et al., Privacy-preserving machine learning with fully homomorphic encryption for deep neural network, *IEEE Access* 10 (2022) 30039–30054.
- [183] X. Sun, P. Zhang, J. K. Liu, J. Yu, W. Xie, Private machine learning classification based on fully homomorphic encryption, *IEEE Transactions on Emerging Topics in Computing* 8 (2) (2018) 352–364.



- [184] C. Zhang, S. Li, J. Xia, W. Wang, F. Yan, Y. Liu, {BatchCrypt}: Efficient homomorphic encryption for {Cross-Silo} federated learning, in: 2020 USENIX annual technical conference (USENIX ATC 20), 2020, pp. 493–506.
- [185] C. Zhao, S. Zhao, M. Zhao, Z. Chen, C.-Z. Gao, H. Li, Y.-a. Tan, Secure multi-party computation: theory, practice and applications, *Information Sciences* 476 (2019) 357–372.
- [186] O. Goldreich, Secure multi-party computation, Manuscript. Preliminary version 78 (110) (1998) 1–108.
- [187] V. Chen, V. Pastro, M. Raykova, Secure computation for machine learning with spdz, arXiv preprint arXiv:1901.00329 (2019).
- [188] B. Knott, S. Venkataraman, A. Hannun, S. Sengupta, M. Ibrahim, L. van der Maaten, Crypten: Secure multi-party computation meets machine learning, *Advances in Neural Information Processing Systems* 34 (2021) 4961–4973.
- [189] S. Wagh, D. Gupta, N. Chandran, Securenn: 3-party secure computation for neural network training, *Proceedings on Privacy Enhancing Technologies* (2019).
- [190] S. Wagh, S. Tople, F. Benhamouda, E. Kushilevitz, P. Mittal, T. Rabin, Falcon: Honest-majority maliciously secure framework for private deep learning, arXiv preprint arXiv:2004.02229 (2020).
- [191] I. Damgård, M. Geisler, M. Krøigaard, J. B. Nielsen, Asynchronous multiparty computation: Theory and implementation, in: *International workshop on public key cryptography*, Springer, 2009, pp. 160–179.
- [192] V. Mugunthan, A. Polychroniadou, D. Byrd, T. H. Balch, Smpai: Secure multi-party computation for federated learning, in: *Proceedings of the NeurIPS 2019 Workshop on Robust AI in Financial Services*, Vol. 21, MIT Press Cambridge, MA, USA, 2019.
- [193] P. Jauernig, A.-R. Sadeghi, E. Stempf, Trusted execution environments: properties, applications, and challenges, *IEEE Security & Privacy* 18 (2) (2020) 56–60.

- [194] F. Mo, A. S. Shamsabadi, K. Katevas, S. Demetriou, I. Leontiadis, A. Cavallaro, H. Haddadi, Darknetz: towards model privacy at the edge using trusted execution environments, in: Proceedings of the 18th International Conference on Mobile Systems, Applications, and Services, 2020, pp. 161–174.
- [195] Y. Zhang, Z. Wang, J. Cao, R. Hou, D. Meng, Shufflefl: Gradient-preserving federated learning using trusted execution environment, in: Proceedings of the 18th ACM international conference on computing frontiers, 2021, pp. 161–168.
- [196] F. Mo, H. Haddadi, K. Katevas, E. Marin, D. Perino, N. Kourtellis, Ppfl: Privacy-preserving federated learning with trusted execution environments, in: Proceedings of the 19th annual international conference on mobile systems, applications, and services, 2021, pp. 94–108.
- [197] A. P. Kalapaaking, I. Khalil, M. S. Rahman, M. Atiquzzaman, X. Yi, M. Almashor, Blockchain-based federated learning with secure aggregation in trusted execution environment for internet-of-things, *IEEE Transactions on Industrial Informatics* 19 (2) (2022) 1703–1714.
- [198] A. Mondal, Y. More, R. H. Rooparaghunath, D. Gupta, Poster: Fla-tee: Federated learning across trusted execution environments, in: 2021 IEEE European Symposium on Security and Privacy (EuroS&P), IEEE, 2021, pp. 707–709.
- [199] Z. Liu, J. Guo, K.-Y. Lam, J. Zhao, Efficient dropout-resilient aggregation for privacy-preserving machine learning, *IEEE Transactions on Information Forensics and Security* 18 (2022) 1839–1854.
- [200] S. Kadhe, N. Rajaraman, O. O. Koyluoglu, K. Ramchandran, Fast-secagg: Scalable secure aggregation for privacy-preserving federated learning, arXiv preprint arXiv:2009.11248 (2020).
- [201] K. Bonawitz, V. Ivanov, B. Kreuter, A. Marcedone, H. B. McMahan, S. Patel, D. Ramage, A. Segal, K. Seth, Practical secure aggregation for federated learning on user-held data, arXiv preprint arXiv:1611.04482 (2016).

- [202] P. Kairouz, Z. Liu, T. Steinke, The distributed discrete gaussian mechanism for federated learning with secure aggregation, in: International Conference on Machine Learning, PMLR, 2021, pp. 5201–5212.
- [203] L. Zhao, J. Jiang, B. Feng, Q. Wang, C. Shen, Q. Li, Sear: Secure and efficient aggregation for byzantine-robust federated learning, *IEEE Transactions on Dependable and Secure Computing* 19 (5) (2021) 3329–3342.
- [204] D. Li, Z. Luo, B. Cao, Blockchain-based federated learning methodologies in smart environments, *Cluster Computing* (2021) 1–15.
- [205] H. Kim, J. Park, M. Bennis, S.-L. Kim, On-device federated learning via blockchain and its latency analysis, *arXiv preprint arXiv:1808.03949* (2018).
- [206] Z. Peng, J. Xu, X. Chu, S. Gao, Y. Yao, R. Gu, Y. Tang, Vfchain: enabling verifiable and auditable federated learning via blockchain systems, *IEEE Transactions on Network Science and Engineering* 9 (1) (2021) 173–186.
- [207] H. B. Desai, M. S. Ozdayi, M. Kantarcioglu, Blockfla: Accountable federated learning via hybrid blockchain architecture, in: Proceedings of the eleventh ACM conference on data and application security and privacy, 2021, pp. 101–112.
- [208] Y. Lu, X. Huang, K. Zhang, S. Maharjan, Y. Zhang, Blockchain empowered asynchronous federated learning for secure data sharing in internet of vehicles, *IEEE Transactions on Vehicular Technology* 69 (4) (2020) 4298–4311.
- [209] Y. Qu, L. Gao, T. H. Luan, Y. Xiang, S. Yu, B. Li, G. Zheng, Decentralized privacy using blockchain-enabled federated learning in fog computing, *IEEE Internet of Things Journal* 7 (6) (2020) 5171–5183.
- [210] U. Majeed, C. S. Hong, Flchain: Federated learning via mec-enabled blockchain network, in: 2019 20th Asia-Pacific Network Operations and Management Symposium (APNOMS), 2019, pp. 1–4.
- [211] Q. Lu, X. Xu, Adaptable blockchain-based systems: A case study for product traceability, *IEEE Software* 34 (6) (2017) 21–27.

- [212] A. A. Monrat, O. Schelén, K. Andersson, A survey of blockchain from the perspectives of applications, challenges, and opportunities, *Ieee Access* 7 (2019) 117134–117151.
- [213] D. Preuveneers, V. Rimmer, I. Tsingenopoulos, J. Spooren, W. Joosen, E. Ilie-Zudor, Chained anomaly detection models for federated learning: An intrusion detection case study, *Applied Sciences* 8 (12) (2018) 2663.
- [214] Y. Liu, J. Peng, J. Kang, A. M. Ilyasu, D. Niyato, A. A. Abd El-Latif, A secure federated learning framework for 5g networks, *IEEE Wireless Communications* 27 (4) (2020) 24–31.
- [215] Y. Lin, Z. Gao, H. Du, D. Niyato, J. Wang, Verifiable and efficient semantic blockchain, in: *GLOBECOM 2023-2023 IEEE Global Communications Conference*, IEEE, 2023, pp. 2602–2607.
- [216] Y. Lin, C. Wu, M. L. Fikri, J. Wu, J. Li, L. Zhong, Y. Ji, Blockchain-based edge-assisted knowledge base management for semantic communication in remote driving, in: *2023 IEEE 31st International Conference on Network Protocols (ICNP)*, IEEE, 2023, pp. 1–6.
- [217] B. Li, C. Chenli, X. Xu, Y. Shi, T. Jung, Dlbc: A deep learning-based consensus in blockchains for deep learning services, *arXiv preprint arXiv:1904.07349* (2019).
- [218] C. Liang, B. Shanmugam, S. Azam, A. Karim, A. Islam, M. Zamani, S. Kavianpour, N. B. Idris, Intrusion detection system for the internet of things based on blockchain and multi-agent systems, *Electronics* 9 (7) (2020) 1120.
- [219] Y. Li, C. Chen, N. Liu, H. Huang, Z. Zheng, Q. Yan, A blockchain-based decentralized federated learning framework with committee consensus, *IEEE Network* 35 (1) (2020) 234–241.
- [220] Y. Lu, X. Huang, K. Zhang, S. Maharjan, Y. Zhang, Blockchain empowered asynchronous federated learning for secure data sharing in internet of vehicles, *IEEE Transactions on Vehicular Technology* 69 (4) (2020) 4298–4311.

- [221] H. Kim, J. Park, M. Bennis, S.-L. Kim, Blockchained on-device federated learning, *IEEE Communications Letters* 24 (6) (2019) 1279–1283.
- [222] S. Rathore, B. W. Kwon, J. H. Park, Blockseciotnet: Blockchain-based decentralized security architecture for iot network, *Journal of Network and Computer Applications* 143 (2019) 167–177.
- [223] S. Lugan, P. Desbordes, E. Brion, L. X. R. Tormo, A. Legay, B. Macq, Secure architectures implementing trusted coalitions for blockchained distributed learning (tclearn), *Ieee Access* 7 (2019) 181789–181799.
- [224] S. Awan, F. Li, B. Luo, M. Liu, Poster: A reliable and accountable privacy-preserving federated learning framework using the blockchain, in: *Proceedings of the 2019 ACM SIGSAC conference on computer and communications security*, 2019, pp. 2561–2563.
- [225] M. Shayan, C. Fung, C. J. Yoon, I. Beschastnikh, Biscotti: A blockchain system for private and secure federated learning, *IEEE Transactions on Parallel and Distributed Systems* 32 (7) (2020) 1513–1525.
- [226] Y. Jiang, S. Wang, V. Valls, B. J. Ko, W.-H. Lee, K. K. Leung, L. Tasoulas, Model pruning enables efficient federated learning on edge devices, *IEEE Transactions on Neural Networks and Learning Systems* 34 (12) (2022) 10374–10386.
- [227] S. Ding, L. Zhang, M. Pan, X. Yuan, Patrol: Privacy-oriented pruning for collaborative inference against model inversion attacks, in: *Proceedings of the IEEE/CVF Winter Conference on Applications of Computer Vision*, 2024, pp. 4716–4725.
- [228] Y. Wang, C. Wang, Z. Wang, S. Zhou, H. Liu, J. Bi, C. Ding, S. Rajasekaran, Against membership inference attack: Pruning is all you need, *arXiv preprint arXiv:2008.13578* (2020).
- [229] X. Yuan, L. Zhang, Membership inference attacks and defenses in neural network pruning, in: *31st USENIX Security Symposium (USENIX Security 22)*, 2022, pp. 4561–4578.
- [230] S. Ye, K. Xu, S. Liu, H. Cheng, J.-H. Lambrechts, H. Zhang, A. Zhou, K. Ma, Y. Wang, X. Lin, Adversarial robustness vs. model compression,

- or both?, in: Proceedings of the IEEE/CVF International Conference on Computer Vision, 2019, pp. 111–120.
- [231] A. Gholami, S. Kim, Z. Dong, Z. Yao, M. W. Mahoney, K. Keutzer, A survey of quantization methods for efficient neural network inference, in: *Low-Power Computer Vision*, Chapman and Hall/CRC, 2022, pp. 291–326.
- [232] M. Nagel, M. Fournarakis, R. A. Amjad, Y. Bondarenko, M. Van Baalen, T. Blankevoort, A white paper on neural network quantization, arXiv preprint arXiv:2106.08295 (2021).
- [233] J. Lee, D. Kim, B. Ham, Network quantization with element-wise gradient scaling, in: Proceedings of the IEEE/CVF conference on computer vision and pattern recognition, 2021, pp. 6448–6457.
- [234] Y. Bhalgat, J. Lee, M. Nagel, T. Blankevoort, N. Kwak, Lsq+: Improving low-bit quantization through learnable offsets and better initialization, in: Proceedings of the IEEE/CVF conference on computer vision and pattern recognition workshops, 2020, pp. 696–697.
- [235] W. Shao, M. Chen, Z. Zhang, P. Xu, L. Zhao, Z. Li, K. Zhang, P. Gao, Y. Qiao, P. Luo, Omniquant: Omnidirectionally calibrated quantization for large language models, arXiv preprint arXiv:2308.13137 (2023).
- [236] Y. Xu, L. Xie, X. Gu, X. Chen, H. Chang, H. Zhang, Z. Chen, X. Zhang, Q. Tian, Qa-lora: Quantization-aware low-rank adaptation of large language models, arXiv preprint arXiv:2309.14717 (2023).
- [237] S. Swaminathan, D. Garg, R. Kannan, F. Andres, Sparse low rank factorization for deep neural network compression, *Neurocomputing* 398 (2020) 185–196.
- [238] J. Xue, Y. Zhao, S. Huang, W. Liao, J. C.-W. Chan, S. G. Kong, Multilayer sparsity-based tensor decomposition for low-rank tensor completion, *IEEE Transactions on Neural Networks and Learning Systems* 33 (11) (2021) 6916–6930.
- [239] A.-H. Phan, K. Sobolev, K. Sozykin, D. Ermilov, J. Gusak, P. Tichavský, V. Glukhov, I. Oseledets, A. Cichocki, Stable low-rank tensor decomposition for compression of convolutional neural network,

- in: Computer Vision–ECCV 2020: 16th European Conference, Glasgow, UK, August 23–28, 2020, Proceedings, Part XXIX 16, Springer, 2020, pp. 522–539.
- [240] Y. Idelbayev, M. A. Carreira-Perpinán, Low-rank compression of neural nets: Learning the rank of each layer, in: Proceedings of the IEEE/CVF Conference on Computer Vision and Pattern Recognition, 2020, pp. 8049–8059.
- [241] V. Piratla, P. Netrapalli, S. Sarawagi, Efficient domain generalization via common-specific low-rank decomposition, in: International conference on machine learning, PMLR, 2020, pp. 7728–7738.
- [242] S. I. Mirzadeh, M. Farajtabar, A. Li, N. Levine, A. Matsukawa, H. Ghasemzadeh, Improved knowledge distillation via teacher assistant, in: Proceedings of the AAAI conference on artificial intelligence, Vol. 34, 2020, pp. 5191–5198.
- [243] U. Asif, J. Tang, S. Harrer, Ensemble knowledge distillation for learning improved and efficient networks, in: ECAI 2020, IOS Press, 2020, pp. 953–960.
- [244] G. Wu, S. Gong, Peer collaborative learning for online knowledge distillation, in: Proceedings of the AAAI Conference on artificial intelligence, Vol. 35, 2021, pp. 10302–10310.
- [245] H. Zhang, Z. Hu, W. Qin, M. Xu, M. Wang, Adversarial co-distillation learning for image recognition, *Pattern Recognition* 111 (2021) 107659.
- [246] Z. Zhang, M. Sabuncu, Self-distillation as instance-specific label smoothing, *Advances in Neural Information Processing Systems* 33 (2020) 2184–2195.
- [247] M. Gao, Y. Wang, L. Wan, Residual error based knowledge distillation, *Neurocomputing* 433 (2021) 154–161.
- [248] N. Papernot, P. McDaniel, X. Wu, S. Jha, A. Swami, Distillation as a defense to adversarial perturbations against deep neural networks, in: 2016 IEEE symposium on security and privacy (SP), IEEE, 2016, pp. 582–597.

- [249] S. Ham, J. Park, D.-J. Han, J. Moon, Neo-kd: knowledge-distillation-based adversarial training for robust multi-exit neural networks, *Advances in Neural Information Processing Systems* 36 (2024).
- [250] M. Zhang, G. Zhu, R. Jin, X. Chen, Q. Shi, C. Zhong, K. Huang, Beamforming design for semantic-bit coexisting communication system, *arXiv preprint arXiv:2403.11693* (2024).
- [251] M. Wu, Z. Gao, Z. Wang, D. Niyato, G. K. Karagiannidis, S. Chen, Deep joint semantic coding and beamforming for near-space airborne massive mimo network, *arXiv preprint arXiv:2405.19889* (2024).
- [252] A. D. Raha, A. Adhikary, M. Gain, Y. M. Park, C. S. Hong, Towards ultra-reliable 6g: Semantics empowered robust beamforming for millimeter-wave networks, in: *NOMS 2024-2024 IEEE Network Operations and Management Symposium*, IEEE, 2024, pp. 1–7.
- [253] A. D. Raha, K. Kim, A. Adhikary, M. Gain, Z. Han, C. S. Hong, Advancing ultra-reliable 6g: Transformer and semantic localization empowered robust beamforming in millimeter-wave communications, *arXiv preprint arXiv:2406.02000* (2024).
- [254] W. Zhang, J. Chen, Y. Kuo, Y. Zhou, Artificial-noise-aided optimal beamforming in layered physical layer security, *IEEE Communications Letters* 23 (1) (2018) 72–75.
- [255] Y. Jiang, Y. Zou, J. Ouyang, J. Zhu, Secrecy energy efficiency optimization for artificial noise aided physical-layer security in ofdm-based cognitive radio networks, *IEEE Transactions on Vehicular Technology* 67 (12) (2018) 11858–11872.
- [256] C. Wang, Z. Li, X.-G. Xia, J. Shi, J. Si, Y. Zou, Physical layer security enhancement using artificial noise in cellular vehicle-to-everything (c-v2x) networks, *IEEE Transactions on Vehicular Technology* 69 (12) (2020) 15253–15268.
- [257] T. V. Pham, A. T. Pham, S. Ishihara, Design of energy-efficient artificial noise for physical layer security in visible light communications, *IEEE Transactions on Green Communications and Networking* (2024).



- [258] X. Luo, B. Yin, Z. Chen, B. Xia, J. Wang, Autoencoder-based semantic communication systems with relay channels, in: 2022 IEEE International Conference on Communications Workshops (ICC Workshops), IEEE, 2022, pp. 711–716.
- [259] Z. Hu, C. You, T. Liu, D. Wen, Y. Hu, Y. Cui, Y. Gong, K. Huang, Semantic communication meets edge intelligence: Semantic-relay-aided text transmissions, *IEEE Internet of Things Journal* (2024).
- [260] B. Tang, L. Huang, Q. Li, A. Pandharipande, X. Ge, Cooperative semantic communication with on-demand semantic forwarding, *IEEE Open Journal of the Communications Society* (2023).
- [261] W. Lin, Y. Yan, L. Li, Z. Han, T. Matsumoto, Semantic-forward relaying: A novel framework towards 6g cooperative communications, *IEEE Communications Letters* (2024).
- [262] J. Guo, H. Chen, B. Song, Y. Chi, C. Yuen, F. R. Yu, G. Y. Li, D. Niyato, Distributed task-oriented communication networks with multimodal semantic relay and edge intelligence, *IEEE Communications Magazine* (2024).
- [263] H. Du, J. Wang, D. Niyato, J. Kang, Z. Xiong, J. Zhang, X. Shen, Semantic communications for wireless sensing: Ris-aided encoding and self-supervised decoding, *IEEE Journal on Selected Areas in Communications* 41 (8) (2023) 2547–2562.
- [264] L. Wang, W. Wu, F. Zhou, Z. Qin, Q. Wu, Irs-enhanced secure semantic communication networks: Cross-layer and context-awared resource allocation, *arXiv preprint arXiv:2411.01821* (2024).
- [265] Y. Huang, C. Cai, X. Yuan, Y.-J. A. Zhang, Joint active and passive beamforming for ris-aided semantic communication, *IEEE Transactions on Vehicular Technology* (2024).
- [266] S. Chen, Y. Hui, Y. Qin, Y. Yuan, W. Meng, X. Luo, H.-H. Chen, Ris-based on-the-air semantic communications—a diffractive deep neural network approach, *IEEE Wireless Communications* (2024).

- [267] Y. Wang, W. Yang, P. Guan, Y. Zhao, Z. Xiong, Star-ris-assisted privacy protection in semantic communication system, *IEEE Transactions on Vehicular Technology* (2024).
- [268] N. Aldaghri, H. Mahdavifar, Physical layer secret key generation in static environments, *IEEE Transactions on Information Forensics and Security* 15 (2020) 2692–2705.
- [269] X. Zhang, G. Li, J. Zhang, A. Hu, Z. Hou, B. Xiao, Deep-learning-based physical-layer secret key generation for fdd systems, *IEEE Internet of Things Journal* 9 (8) (2021) 6081–6094.
- [270] L. Jin, X. Xu, S. Han, J. Liu, R. Meng, H. Chen, Ris-assisted physical layer key generation and transmit power minimization, in: *2022 IEEE Wireless Communications and Networking Conference (WCNC)*, IEEE, 2022, pp. 2065–2070.
- [271] N. Gao, Y. Han, N. Li, S. Jin, M. Matthaiou, When physical layer key generation meets ris: Opportunities, challenges, and road ahead, *IEEE Wireless Communications* (2024).
- [272] R. Zhao, Q. Qin, N. Xu, G. Nan, Q. Cui, X. Tao, Semkey: Boosting secret key generation for ris-assisted semantic communication systems, in: *2022 IEEE 96th Vehicular Technology Conference (VTC2022-Fall)*, IEEE, 2022, pp. 1–5.
- [273] R. Meng, B. Xu, X. Xu, M. Sun, B. Wang, S. Han, S. Lv, P. Zhang, A survey of machine learning-based physical-layer authentication in wireless communications, *Journal of Network and Computer Applications* (2024) 104085.
- [274] N. Gao, Q. Huang, C. Li, S. Jin, M. Matthaiou, Esanet: Environment semantics enabled physical layer authentication, *IEEE Wireless Communications Letters* (2023).
- [275] R. Meng, X. Xu, B. Wang, H. Sun, S. Xia, S. Han, P. Zhang, Physical-layer authentication based on hierarchical variational autoencoder for industrial internet of things, *IEEE Internet of Things Journal* 10 (3) (2022) 2528–2544.

- [276] R. Meng, X. Xu, H. Zhao, B. Wang, G. Li, B. Xu, P. Zhang, Multiobservation-multichannel-attribute-based multiuser authentication for industrial wireless edge networks, *IEEE Transactions on Industrial Informatics* 20 (2) (2023) 2097–2108.
- [277] R. Meng, X. Xu, G. Li, B. Xu, F. Zhu, B. Wang, P. Zhang, Multi-dimensional fingerprints-based multi-attacker detection for 6g systems, *IEEE Internet of Things Journal* (2023).
- [278] Y. Ma, H. Fang, L. Liang, X. Wang, Physical layer authentication enhancement via random watermark hopping, *IEEE Internet of Things Journal* (2024).
- [279] S. Arzykulov, A. Celik, G. Nauryzbayev, A. M. Eltawil, Artificial noise and ris-aided physical layer security: Optimal ris partitioning and power control, *IEEE Wireless Communications Letters* 12 (6) (2023) 992–996.
- [280] R. Meng, F. Zhu, X. Xu, L. Jin, B. Wang, B. Xu, H. Meng, P. Zhang, Efficient gaussian process classification-based physical-layer authentication with configurable fingerprints for 6g-enabled iot, *arXiv preprint arXiv:2307.12263* (2023).