

Maritime Cybersecurity: A Comprehensive Review

MEIXUAN LI, Singapore University of Technology and Design, Singapore

JIANYING ZHOU, Singapore University of Technology and Design, Singapore

SUDIPTA CHATTOPADHYAY, Singapore University of Technology and Design, Singapore

MARK GOH, Singapore University of Technology and Design, Singapore

The maritime industry stands at a critical juncture, where the imperative for technological advancement intersects with the pressing need for robust cybersecurity measures. Maritime cybersecurity refers to the protection of computer systems and digital assets within the maritime industry, as well as the broader network of interconnected components that make up the maritime ecosystem. In this survey, we aim to identify the significant domains of maritime cybersecurity and measure their effectiveness. We have provided an in-depth analysis of threats in key maritime systems, including AIS, GNSS, ECDIS, VDR, RADAR, VSAT, and GMDSS, while exploring real-world cyber incidents that have impacted the sector. A multi-dimensional taxonomy of maritime cyber attacks is presented, offering insights into threat actors, motivations, and impacts. We have also evaluated various security solutions, from integrated solutions to component specific solutions. Finally, we have shared open challenges and future solutions. In the supplementary section, we have presented definitions and vulnerabilities of vessel components that have discussed in this survey. By addressing all these critical issues with key interconnected aspects, this review aims to foster a more resilient maritime ecosystem.

CCS Concepts: • **General and reference** → **Surveys and overviews**; • **Security and privacy** → **Systems security**.

Additional Key Words and Phrases: Maritime cyberattacks, maritime cybersecurity, maritime incidents, operational technology system, vulnerabilities, threats, countermeasures

ACM Reference Format:

Meixuan Li, Jianying Zhou, Sudipta Chattopadhyay, and Mark Goh. 2024. Maritime Cybersecurity: A Comprehensive Review. *J. ACM* 11, 1, Article 111 (January 2024), 36 pages. <https://doi.org/XXXXXXX.XXXXXXX>

1 INTRODUCTION

The global maritime digital technology industry is estimated to be worth \$345 billion by 2030, up from a previous forecast of \$279 billion [83]. Over the past years, the maritime industry has progressed rapidly and their evolution has extended into several domains. From increased use of digital systems [56], enhanced satellite communication [6], and construction of IoT-enabled port infrastructure [35] to development tendencies of autonomous shipping [89], a lot has been published with a focus on the advancements of maritime technology, but maritime cybersecurity has been inadequately addressed. To be more specific, the maritime industry is at significant risk of becoming a target for an array of cyber threats and attack vectors that arise from the interconnection of diverse technical tools such a Internet of Things (IoT) networks and telecommunications mechanisms, etc.

Authors' addresses: Meixuan Li, Singapore University of Technology and Design, Singapore, li_meixuan@sutd.edu.sg; Jianying Zhou, Singapore University of Technology and Design, Singapore, jianying_zhou@sutd.edu.sg; Sudipta Chattopadhyay, Singapore University of Technology and Design, Singapore, sudipta_chattopadhyay@sutd.edu.sg; Mark Goh, Singapore University of Technology and Design, Singapore, goh_mark@sutd.edu.sg.

Permission to make digital or hard copies of all or part of this work for personal or classroom use is granted without fee provided that copies are not made or distributed for profit or commercial advantage and that copies bear this notice and the full citation on the first page. Copyrights for components of this work owned by others than the author(s) must be honored. Abstracting with credit is permitted. To copy otherwise, or republish, to post on servers or to redistribute to lists, requires prior specific permission and/or a fee. Request permissions from permissions@acm.org.

© 2024 Copyright held by the owner/author(s). Publication rights licensed to ACM.

ACM 0004-5411/2024/1-ART111

<https://doi.org/XXXXXXX.XXXXXXX>

The maritime cyber environment, as described by Sotiria [99], encompasses the networked systems of both Information Technology (IT) and cyber-physical systems [or Operational Technology (OT)]. It includes communication networks that allow data to flow from a ship's IT systems through to the OT realm with programmable logic controllers (PLCs) and various sensors, ultimately extending to advanced navigation tools like Global Positioning Systems (GPS). This has created greater vulnerabilities - the integration of IT and OT in the maritime sector introduces heightened cybersecurity risks, as traditionally isolated OT systems become more susceptible to cyber attacks through their connections to IT networks (depicted in Figure 1). As the range of potential threats has broadened, more vulnerabilities and entry points have been discovered in maritime systems.

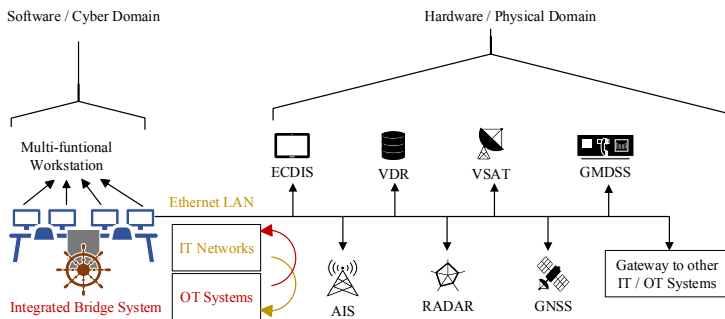

Fig. 1. Illustration of a typical maritime shipboard IT/OT system that combines hardware and software to monitor and control physical devices in real time. The increasing interconnectivity of IT and OT systems have expanded the potential attack surface.

Different from the automotive industry in which their cyberattack impact tend to be more localized, affecting single vehicles or restricted regions, the potential impact of a cyberattack on a large vessel could destabilize global supply chains and inflict billions in economic losses. With the rise of interconnectivity, maritime cybersecurity extends beyond the vessels themselves and is characterized by complex interactions among stakeholders and components, such as shippers and ports. As a result, vessels have become vulnerable to cyberattacks originating both internally and externally.

Several research activities targeted at discovering and studying various cyber threats of the underlying technology are driven by the demands and real-world scenarios regarding maritime cybersecurity listed above. In the last few years, excellent surveys on maritime cybersecurity have been published [10][16][85] [126][174]. Park *et al.* [126] offered a more traditional narrative literature review. Rather than getting into the technical specifics of individual systems or components, the authors [126] adopted a high-level perspective of cybersecurity threats and risk control alternatives in the marine industry as a whole. Ismail *et al.* [85] focused specifically on maritime cybersecurity in the Indian Ocean region with limited depth on maritime component-specific topics. Farah *et al.* [16] provided a mapping and classification of on-vessel core equipment and in-port infrastructure and included a detailed breakdown of electro-mechanical systems, electronic systems and communication systems.

Nevertheless, the authors [16] did not offer comprehensive technical information on particular cybersecurity measures. In contrast to more general maritime cybersecurity, Ashraf *et al.* [10] offered a comprehensive classification of cyberattacks in the marine domain, with a primary focus on risks related to the Internet of Things. Moreover, the authors [10] did not elaborate on

methods of mitigation. Yu *et al.* [174] used bibliometric methods to provide a review of academic literature on maritime cybersecurity with limited discussion of technical details in cybersecurity solutions. There is still room to classify novel threats and countermeasures in literature that are more sophisticated and highly targeted. This work attempts to fill this gap. Although security attacks against maritime IoT devices have received considerable attention during the last years, the significance of IoT enabled attacks is not always fully assessed. We focus on *verified* attacks, i.e, either real-world incidents or attacks that have been implemented and recently published by researchers including the attacks that are theoretically possible. Based on the analysis of these attacks, we summarize security solutions that can effectively mitigate such threats. Unlike many existing survey papers that have limited discussions on countermeasures, this study will provide a thorough review of the latest defensive strategies and technologies. It will cover not only component-specific countermeasures but also integrated solutions that can enhance the overall cybersecurity posture of maritime organizations. Table 1 provides a comparison between this article and other papers covering maritime cybersecurity.

Table 1. Comparison of Our Survey Focus with Focuses of Existing Works

Survey	Component-Based Approach to Maritime Threats Overview	Discussing Broader Maritime Security Issues	Analyzing Maritime Attack Incidents	Holistic Mitigation Measures	Component-specific Mitigation Measures	Including Directions & Challenges
Park <i>et al.</i> [126]	✗	○	●	●	○	✗
Ismail <i>et al.</i> [85]	✗	○	○	●	○	✗
Farah <i>et al.</i> [16]	✓	○	●	○	○	✗
Ashraf <i>et al.</i> [10]	✓	○	○	●	○	✗
Yu <i>et al.</i> [174]	✗	○	●	●	○	✓
Our survey	✓	●	●	●	●	✓

✓=Yes, ✗= No, ○= Not Mentioned, ●= Room for Improvement, ●= Thoroughly Addressed

Based on this context, the main contributions and organizations of our article are as follows: (i) a broader overview of the industry's cybersecurity landscape by examining six key maritime interconnected aspects in Section 3, (ii) Section 4 reviews the threats of vessel components, which include RADio Detection And Ranging (RADAR), Voyage Data Recorders (VDR), Global Navigation Satellite Systems (GNSS) / GPS, Electronic Chart Display and Information Systems (ECDIS), Automatic Identification Systems (AIS), Global Maritime Distress and Safety System (GMDSS) and Very Small Aperture Terminal (VSAT), (iii) a taxonomy that categorizes maritime incidents from 2014 to 2023 targeting various attacks surfaces and systems of vessel in Section 5, (iv) a review of diverse mitigation techniques aimed at addressing security concerns in Section 6, and (v) Section 7 and 8 discuss challenges and potential future directions for maritime cybersecurity. The article is concluded in Section 9. The complete structure of the article is shown in Figure 2.

2 LITERATURE SEARCH METHODOLOGY

2.1 Keywords and Databases

To narrow the scope of this survey and ensure its relevance to the maritime industry and academic research, a comprehensive set of keywords was meticulously chosen. The primary focus is on "shipboard operational technology (OT) systems", "maritime cybersecurity", and "maritime industry". These keywords are often used in conjunction with terms such as "cyber threats", "vulnerabilities", "risks", "mitigation strategies", "countermeasures", and "cyber risk management" to identify the most pertinent literature addressing security challenges, potential risks, and defensive measures within the maritime cybersecurity domain. The following academic research databases were considered:

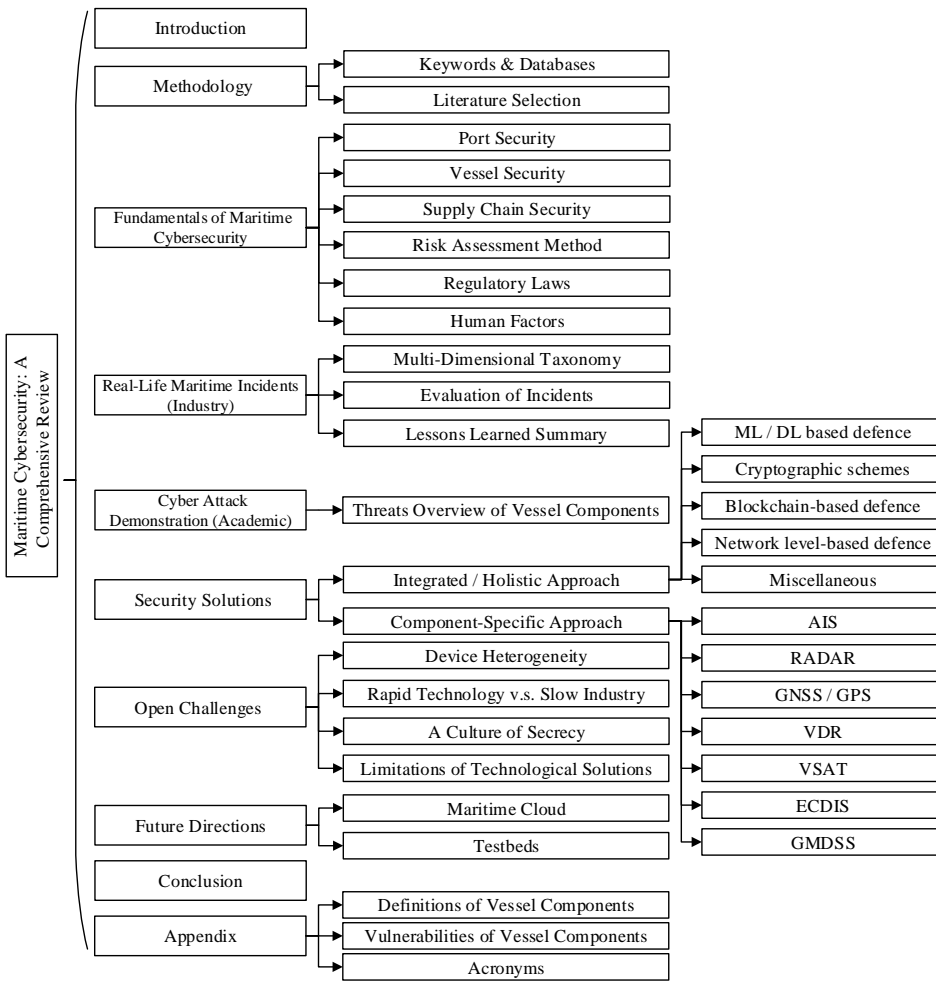

Fig. 2. Structure of this study

Elsevier ScienceDirect, Association for Computing Machinery (ACM) digital library, IEEE Xplore digital library, and SpringerLink.

2.2 Literature Selection

While the selected scholarly databases are known for publishing high-quality research, we found that there was a limited number of studies specifically addressing the security of shipboard OT systems and the maritime industry as a whole. A reason could be that maritime cybersecurity is a niche area that intersects with various domains, and researchers may prefer to publish their work in domain-specific journals and conferences catering to the maritime industry.

To overcome this limitation, the scope was expanded to include non-traditional sources such as technical reports, white papers, and dissertations from reputable maritime associations, societies, and related organizations. These include guidelines and recommendations from the International Maritime Organization (IMO), the American Bureau of Shipping (ABS), the Baltic and International

Maritime Council (BIMCO) and others, which complement the findings from academic publications. Additionally, maritime-specific journals such as The Journal of Navigation, published by Cambridge University Press, and the Journal of Marine Science and Engineering, an open-access journal by MDPI, were consulted to capture the latest developments and research in the field.

3 CHALLENGES IN MARITIME CYBERSECURITY

As technology continues to advance and integrate into every aspect of maritime operations, the sector must confront vulnerabilities across multiple fronts. From the security of port facilities and vessels to the human factors influencing cyber risk, the maritime environment presents a unique set of challenges. These challenges are further complicated by the need for robust risk assessment methods, the intricacies of supply chain security, and the evolving regulations (see Figure 3).

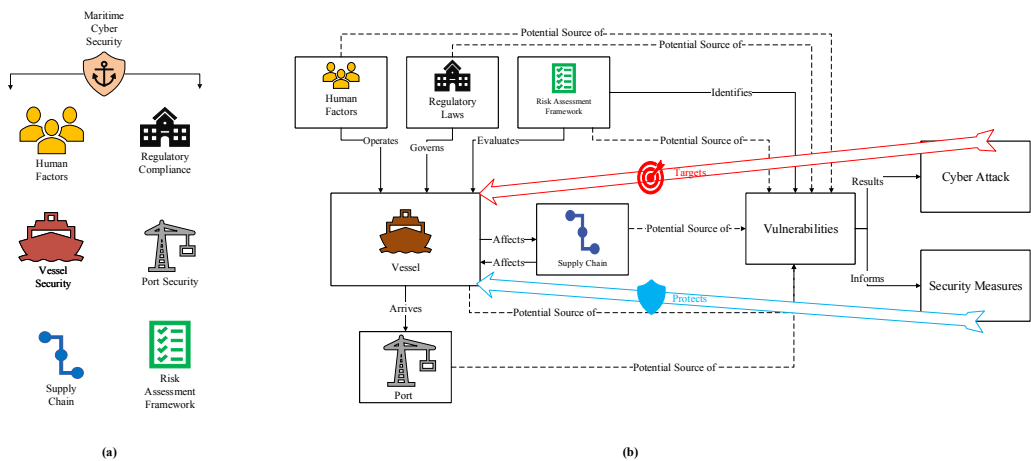

Fig. 3. Six challenges in maritime cybersecurity (a) and the connection between them (b)

3.1 Vessel Security

Vessel security forms the cornerstone of maritime cybersecurity, interacting with and influencing other critical aspects of the maritime network. Crew members are on the front lines of implementing security measures and are often the first to detect and respond to security threats. However, human factors can also introduce vulnerabilities (e.g. neglect security procedures). Well-trained crew members who are aware of security protocols and potential threats can significantly enhance a vessel’s security posture [17]. Vessel security is also governed by a complex web of international laws, conventions, and industry standards which set out comprehensive security-related requirements for ships, ports, and government agencies. Although most marine incidents resulted from shortage in applying international regulations related to maritime safety [1], compliance with these regulatory frameworks should be viewed as a minimum standard rather than the ultimate goal of security efforts. When a vessel enters a port, it becomes subject to the port’s security procedures and infrastructure. The port security management measures can refer to the subsequent port security section (Section 3.2). The increasing digitization of port operations, including the use of automated systems for cargo handling and vessel traffic management, creates new cybersecurity considerations for vessels [81]. Risk assessment methodology aims help systematically identify potential security threats to a vessel and includes the protection of human life and health [125]. Based on the identified

risks, these methods guide the development of appropriate security measures and contingency plans. In global supply chains, transit times are heavily influenced by vessel speed and routes. Vessel operations are generally under significant time pressure, aligning with the "just-in-time" philosophy underlying most modern supply chains [105]. This pressure might cause hasty security decisions, which could jeopardize vessel safety by emphasizing temporary solutions over long-term security solutions. Since many vessel components are integrated systems made by multiple companies that operate in different industries, producers must have a deep awareness of the hazards associated with the supply chain [33].

This study examines the security of a particular part of the Integrated Bridge System (IBS), which could be a point of attack for ships. The security of the IBS is crucial as it represents a central point of control for the vessel. A vast network of systems and components is used by ships to function well in the challenging marine environment. These include navigation systems, communication equipment, and various sensors and actuators distributed throughout the ship. Better efficiency and operational capabilities are made possible by this integration, but there is a risk as well: if one component is hacked, it may give access to all other systems [59].

3.2 Port Security

With forecasts showing a strong compound annual growth rate of 7.3% from 2023 to 2031, the worldwide port security market is expected to increase significantly and could reach an estimated value of \$173.59 billion by the end of this time [82]. This trajectory reflects the continued development of security solutions to counter new threats in marine commerce, as well as the growing acknowledgment of port security as an essential part of the infrastructure of global trade. When port security is applied comprehensively, it includes a wide range of policies, practices, and systems that are put in place to protect port operations, infrastructure, and surrounding areas against a variety of threats, such as theft, smuggling, terrorism, and other criminal activity [145]. In order to combat the growing threat of combined cyber-physical attacks for ports, the future of port security is probably going to center on merging cyber and physical security measures [2]. Its multifaceted nature highlights its complexity, necessitating the combination of technological, procedural, and physical protections to build a strong defense against both traditional and emerging threats.

Numerous studies have addressed port infrastructure risk in detail [88][131][132]. Port security management plays a vital role in reducing a wide range of risks and threats that are present in maritime environments. This strategy includes a number of essential elements to protect maritime operations and infrastructure, including emergency response plans, surveillance and monitoring, perimeter security, access control systems, and cargo screening [34]. While access control systems use sophisticated identification credentials, biometric technologies (such as fingerprint scanning and facial recognition), and screening procedures to regulate entry to sensitive areas, perimeter protection uses cutting-edge fencing systems, barriers, and intrusion detection technologies to create a secure boundary around port facilities [98]. Furthermore, state-of-the-art monitoring systems for ship movements in port waters, along with non-intrusive cargo inspection methods like X-ray scanners and RFID tracking for cargo integrity, support prompt response times to security incidents [34]. The integrity, safety, and operational continuity of port infrastructures—which are crucial hubs in both national security frameworks and international trade networks—must be preserved by the integration of these security measures.

3.3 Supply Chain Security

In this sense, supply chain security refers to the laws, practices, and technological advancements created to protect physical items, information flows, and supply chain assets against threats such as theft, terrorism, and natural catastrophes [173]. The process of moving commodities by sea, involving

shipping, port operations, and frequently interior transportation, is referred to as a maritime supply chain. This intricate system connects numerous ports spread over several nations and continents and encompasses a wide spectrum of stakeholders, including freight forwarders, shippers, carriers, and customs officials. The maritime supply chain is faced with a number of difficulties that could seriously jeopardize operational effectiveness and security. Among the many potential reasons of port interruptions, there include worker strikes, natural catastrophes, equipment malfunctions, and cyberattacks [166]. Port disruptions are considered a critical vulnerability. Information security threats, such as cyberattacks on logistics management systems and data breaches revealing private shipping information, pose a significant concern as well [107]. Physical security threats to marine supply chains include piracy (in high-risk maritime zones), cargo theft, and the smuggling of illegal commodities [173]. These are problems that have not yet been properly resolved. As a result of continued climate change and rising sea levels, port infrastructure and shipping routes are becoming more and more susceptible to catastrophic weather events [15]. Furthermore, operational risks such as equipment failures, delays in cargo handling, and human mistake in logistics planning can have a major impact on the efficiency of supply chains. Considering that over 80% of worldwide trade is carried out by marine means [161], any physical interruption to the movement of products around the world would be catastrophic.

The suppliers' perspective is a crucial aspect of the marine supply chain, particularly with regard to the tools and equipment they provide that are essential to numerous nautical systems. This aspect of supply chain security is vital and warrants detailed examination to fully understand the scope of maritime supply chain security. The maritime sector includes a range of specialized technology, including cargo handling devices, propulsion systems, communication tools, and numerous sensors. A breach in one or more product supply chains might lead to many vulnerabilities in important maritime systems. Malicious actors attempting to install hardware or software intended to interfere with operations and obtain unauthorized access may take advantage of these vulnerabilities [108]. On the other hand, it may lead to the replacement of original parts with fake or inferior ones, which would raise the danger of equipment malfunctions and security issues [173]. Moreover, the introduction of malicious code into software or firmware during the manufacturing process may result in the creation of a backdoor that allows for unauthorized control [166].

3.4 Risk Assessment Method

Risk assessment techniques offer a proactive approach to identifying and minimizing potential dangers, assist in preventing accidents, reduce potential financial losses, and comply with regulatory requirements. Unlike [77], this study does not attempt to comprehensively review every risk assessment technique used in the marine context. Rather, we concentrate on a range of typical approaches and group them into five main categories: (1) data-driven; (2) semi-quantitative; (3) qualitative; (4) quantitative; and (5) emergent methods.

The goal of quantitative methods is to provide numerical estimates of risk probabilities and consequences. These methods can be further classified into two categories: (a) artificial intelligence and machine learning techniques, such as Long Short-Term Memory (LSTM) networks [177], and (b) probabilistic and statistical approaches, such as Bayesian networks [13]. These techniques are helpful for comparing various hazards or evaluating the efficacy of risk reduction strategies, but they typically call for a significant amount of data. Qualitative methods can be broadly classified into two categories: (a) hazard identification - Hazard and Operability Analysis (HAZOP) [176]; and (b) system-based approaches - Systems Theoretic Process Analysis (STPA) [153]. The former focuses on identifying and characterizing potential hazards and risks without necessarily quantifying them. These techniques are especially helpful for complex systems where quantification may be difficult and in the early phases of risk assessment. In order to provide a more nuanced assessment than

simply qualitative methods, semi-quantitative methods mix qualitative and quantitative approaches. They typically use scoring or ranking systems without the full complexity of quantitative methods. They include (a) human factor analysis, or Human Factors Analysis and Classification System (HFACS) [30], and (b) failure analysis, or Failure Mode, Effects, and Criticality Analysis (FMECA) [50]. Large datasets are a major component of data-driven approaches, which use them to find patterns, trends, and connections pertaining to marine threats. Examples include (a) association rules-based data mining and analysis techniques [32] and (b) geographic information system (GIS)-based geospatial analysis [164]. Additionally, more recent methods are beginning to emerge, including knowledge graphs [54]. Every approach has its own advantages and works well for various aspects of maritime risk assessment.

Nonetheless, the lack of an internationally recognized standard for marine cyber risk assessment techniques could be the source of any discrepancies. Accurately estimating the financial, operational, and reputational implications of cyber incidents can be difficult for those quantitative approaches [87]. Above all, there might not be enough people with cybersecurity and maritime experience to perform comprehensive risk assessments [4].

3.5 Regulatory Frameworks/Laws

The IMO Resolution MSC.428(98) on Maritime Cyber Risk Management in Safety Management Systems [80] affirms that cyber risks must be appropriately addressed in safety management systems. The Baltic and International Maritime Council (BIMCO) guidelines [20] emphasize the importance of a risk-based approach to cybersecurity and provide detailed advice on implementing cybersecurity measures throughout a vessel's lifecycle. The International Ship and Port Facility Security (ISPS) Code [37] requires ships and port facilities to conduct security assessments, develop security plans, and appoint security officers. The National Institute of Standards and Technology (NIST) Cybersecurity Framework has been widely adopted across sectors, including maritime. Many maritime organizations are using the NIST framework as a basis for developing their cybersecurity strategies, as it offers a flexible and risk-based approach that can be adapted to the specific needs of maritime operations.

These regulations can become outdated quickly in the face of evolving cyber threats and create vulnerabilities in maritime cybersecurity. There has been issues in lack of standards for new technologies [150]. This shows how regulatory frameworks can lag behind technological innovations. Besides, many regulations don't provide detailed technical standards and leave much open to interpretation. Most importantly, they don't fully account for the rapid cyber threats and leave ships vulnerable to new attack vectors. For example, the ISPS Code was primarily designed to enhance maritime security against terrorism threats. Many shipping companies focused on meeting the minimum requirements of the ISPS Code. Ships compliant with ISPS might still be vulnerable to cyber attacks, as the compliance requirements didn't comprehensively cover the evolving cyber threat landscape.

3.6 Human Factor

Empirical research suggests that human factors account for 65.8% to 80% of maritime incidents, with human-related events and actions being identified as the key contributing reason [146]. This diverse field includes a number of important elements: 1) personal cognitive aspects, such as mental workload, situation awareness, and decision-making techniques; 2) physiological elements, including exhaustion, stress, and irregularities in the circadian rhythm; 3) Interpersonal factors, which include issues with coordination, poor communication, and team dynamics; 4) the interplay between humans and machines, especially in light of the growing automation and technological

complexity of maritime operations; 5) Organizational elements, such as management procedures, safety culture, and production pressure [45][53][64].

A paradigm change towards more nuanced considerations of human aspects in operating methods is required due to the mounting body of evidence indicating the significant role of human factors to maritime events. Task performance is directly influenced by cognitive and physiological aspects at the microlevel. For example, it has been demonstrated that fatigue, a well-known problem in the marine industry, impairs cognitive abilities including attention, decision-making, and situational awareness, which may result in mistakes made during navigation or a delay in reacting to urgent situations [75]. Interpersonal dynamics and the human-machine interaction significantly influence group performance at the mesolevel. Poor interface design can cause mode confusion or automation surprises, and inadequate team interactions can contribute to mistake chains that result in incidents [29]. Human factors can play a significant influence in shaping corporate safety culture and policy formulation at a macro level. On the other hand, a weak safety culture may put short-term operational efficiency ahead of long-term safety considerations [70]. A strong safety culture can promote proactive risk management techniques and near-miss reporting. As a result, the incorporation of organizational, structural, individual, and team perspectives has highlighted the critical role that human factors play in the field of maritime cybersecurity.

4 MARITIME CYBER ATTACKS

We review existing cyber attacks on the various maritime systems, both attacks presented in academic research and by industry. Researchers in academic institutions often have the time and resources to conduct in-depth studies, analyzing attack patterns, investigating novel threat vectors, and exploring theoretical vulnerabilities that may not yet have been exploited in real-world scenarios. Industry reports often detail actual incidents, offering specifics about attack methods, targets, and outcomes that academic research might not have access to. Stakeholders in the maritime sector can gain from a combination of theoretical knowledge and practical experience by examining both industry reports and university research.

4.1 Real-Life Maritime Incidents (Industry)

Various reports on maritime cyber issues in recent years indicate an increase in both the number and sophistication of cyber incidents targeting shipping. These individual attacks range from ransomware against port systems to global GPS spoofing affecting vessel navigation. While precise incident numbers may vary due to different reporting methods and definitions of cyber incidents, there is a general consensus that the maritime sector has experienced a rise in threats.

4.1.1 Multi-dimensional Attack Taxonomy. A well-defined taxonomy based on these dimensions (as illustrated in Figure 4) can provide stakeholders in the maritime industry—shipbuilders, operators, and cybersecurity experts—with important new information about the types and extent of cyberthreats that affect the industry. A comprehensive analysis of all maritime incidents is outside the purview of this article, even though various studies have given an overview of noteworthy, publicly revealed cyber attack occurrences [116][122][142][144]. The following significant factors have been taken into consideration while mapping the marine incidents into our multi-dimensional attack taxonomy:

- (1) *Threat Actor:* A threat actor is an entity, either external (e.g., cybercriminals, nation-states, hackers) or internal (e.g., disgruntled employees or contractors), that seeks to compromise the IT or OT security of a maritime system, network, or organization.



Fig. 4. Multi-dimensional Maritime Cyber Attack Taxonomy

- (2) *Impact Area*: The specific location or environment affected by a maritime incident, which can be categorized as vessel (e.g., onboard systems, cargo, and crew) and shore (e.g., port facilities and logistics)
- (3) *Attack Motivation*: The underlying reasons or incentives driving a threat actor to target and compromise a maritime system, network, or organisation. Common motivations include financial gain, espionage, political objectives, competitive advantage or the desire to disrupt operations.
- (4) *Impact*: The negative effects or consequences of a cybersecurity incident on a maritime organization. The exact impact could result in an excessive amount of terms but it can be broadly categorized into operational (e.g., interruption of critical functions), financial (e.g., ransom payments), reputational (e.g., damage to the brand), safety (e.g., crew), legal and regulatory (e.g., violation of laws).
- (5) *Targeted Principle*: The main intention of a threat actor’s compromise of a network, organization, or marine system. The three core concepts of the aim are availability, integrity, and confidentiality. Unauthorized access to sensitive information is referred to as confidentiality. Unauthorized alteration or tampering with data or systems is referred to as integrity. Disruption or lack of access to essential resources is referred to as availability.
- (6) *Victim Country*: The determination of jurisdiction may depend on whose territorial waters the ship was in at the time of the incident, or under which flag the affected ship is registered. For the purposes of reporting, establishing jurisdiction, and facilitating international collaboration in incident response and investigation, it may be necessary to identify the victim nation.

- (7) *Affected System*: Any shipboard IT or OT system, network, or equipment that has been compromised, damaged, or disrupted as a result of a maritime incident.
- (8) *Threat Category*: A grouping of cybersecurity threats that share similar characteristics such as the type of attacker, the method of attack, or the target of the attack.

4.1.2 Evaluation of Incidents by 2014 - 2023. Cybercriminals have been targeting the marine sector, which includes ports, ships, shipping firms, and maritime authorities, more and more in recent years. The marine industry is becoming more and more susceptible to sophisticated cyberattacks, thus recent occurrences need to be closely examined. This section therefore concentrates on cyberattacks that have happened in the last ten years, specifically from 2014 to 2023. A thorough analysis has been conducted on the twenty chosen maritime events (see Table 2 for the evaluation and Figure 5 for the timeline). Our goal is to contribute to a better understanding of the changing cyber threat landscape by exploring particular categories of contributing elements that may have been missed or insufficiently addressed in the literature that has already been published.

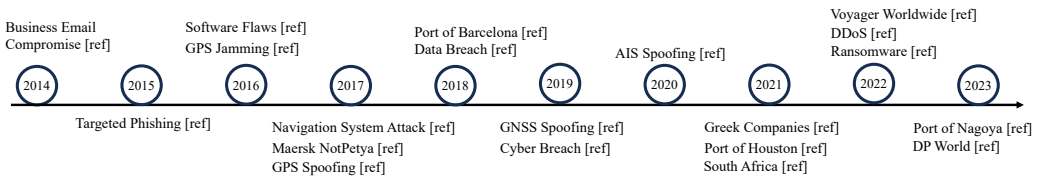

Fig. 5. The timeline of the significant maritime cyber attack incidents

Business Email Compromise (BEC) in Dubai [74]: In 2014, Nautilus Minerals and Dubai-based marine solutions company Marine Assets Corporation (MAC) fell victim to a BEC attack, an attack that tricked Nautilus paying a \$10 million deposit intended for MAC into a fraudulent bank account.

Targeted Phishing in Limassol [21]: A Cyprus-based shipping company suffered a targeted phishing attack that resulted in a \$644,000 loss. The attacker carefully mimicked the legitimate bunker supplier's email communications and requested the funds to be sent to a different bank account. The fraud was discovered when the legitimate fuel company contacted the shipping company for the outstanding payment.

GPS Jamming in South Korea [169]: In 2016, South Korea experienced a series of GPS jamming attacks that affected hundreds of ship, causing significant disruptions to navigation. The attacks, believed to have originated from hackers in North Korea, highlighted the vulnerability of GPS systems.

Software Flaws in U.S. Ports [36]: Navis WebAccess, a web-based application essential for real-time operational data access in ports and logistics worldwide, was discovered to have a critical SQL injection vulnerability (CVE-2016-5817). Ethical hacker "bRpsd" publicly disclosed the vulnerability by releasing proof-of-concept (PoC) exploit code. Unfortunately, this disclosure occurred without prior notification to the vendor, potentially putting users at risk from malicious actors exploiting the vulnerability.

Navigation System Attack [22]: In February 2017, hackers seized control of a German-owned container vessel's navigation systems for 10 hours, rendering the captain unable to maneuver. The vessel's IT system was compromised, and onboard experts had to intervene to restore control. Industry sources suggest the attack was an attempt by pirates to divert the ship for boarding and ransom.

Maersk NotPetya Attack [114]: In 2017, the state-backed hacker group Sandworm, infamous for the NotPetya ransomware, launched a devastating cyberattack on Ukrainian businesses and organizations. It was facilitated by a widely used tax accounting software - ME Doc, and NotPetya spread rapidly, crippling computer systems not just in Ukraine, but also at global port terminals controlled by Maersk division. The attack infiltrated nearly 45,000 devices and 4,000 servers across 600 Maersk locations worldwide. This widespread disruption resulted in an estimated \$250-300 million loss in revenue for Maersk.

GPS Spoofing in the Black Sea [58]: In 2017, alarm bells rang out across the Black Sea when over 20 vessels reported their GPS positions as being inland at an airport, reported by U.S. Maritime Administration. This wasn't an isolated glitch – over 20 ships reporting the same false location, coupled with their positions bouncing back and forth between the airport and their true locations, strongly suggests a deliberate and large-scale GPS spoofing attack.

Port of Barcelona Attack [78]: In 2018, the Port of Barcelona in Spain experienced a significant cyber attack that affected its IT systems and caused disruptions to its operations. Due to system instability caused by the compromise, cargo handling efficiency between vessels and trailers significantly decreased, causing major delays in delivery.

Austral Data Breach [41]: In mid-October 2018, Austal, Australia's shipbuilder and defence contractor, suffered a major data breach. Attackers purchased stolen Austal login credentials on the dark web and these credentials were used to gain access to Austal's Australian business data management systems. The attackers attempted to extort Austal by offering to return to the stolen data in exchange for a ransom payment.

GNSS Spoofing in Port of Shanghai [175]: In 2019, several incidents of GNSS (Global Navigation Satellite System) interference were reported in Chinese coastal areas, including the Port of Shanghai. This interference can disrupt or falsify GNSS signals, potentially affecting a vessel's navigation and communication equipment. It has been proposed that the Chinese government might be behind the GPS spoofing incidents, either as a security measure to conceal oil terminals and important government facilities or to evade surveillance of oil imports.

James Fisher and Sons (JFS) [48]: UK-based marine services provider JFS disclosed an unauthorized intrusion into its computer systems. The cyberattack triggered a 5.7% decline in the company's market shares.

AIS Spoofing in Polish Waters [18]: In November 2020, the Automatic Identification System (AIS) location data for the USS Roosevelt was spoofed. Threat actors, potentially linked to Russia, manipulated the AIS data to show the vessel near the Russian enclave of Kaliningrad, when it was actually elsewhere. The false AIS data could serve to create a narrative portraying Russia as the victim of encroaching naval activity.

Death Kitty Ransomware [60]: Transnet, a South Africa-based transport company, recently fell victim to a Death Kitty ransomware attack targeting its computer and NAVIS systems. This cyber incident has resulted in significant disruptions to Transnet's operations, with potential impacts lasting up to a week. The attack specifically targeted the company's port operations, leading to a complete seizure of port activities and a halt in the movement of cargo until the affected systems are fully restored.

Attack on Greek Companies [12]: In 2011, the companies impacted by the cyberattack leveraged the communication systems provided by Danaos Management Consultants, based in the coastal community of Piraeus in Greater Athens. This attack disrupted their ability to communicate with various stakeholders, including ships, suppliers, agents, charterers, and other key partners. Additionally, the cyber incident resulted in the loss of correspondence files crucial for their operations.

Attack on the Port of Houston [124]: The Port of Houston in the USA encountered a cyber attack targeting its computer network. The attackers attempted to exploit a zero-day vulnerability, indicating that the flaw was not previously known to the software creator. The nature of the attack suggested the involvement of a nation-state actor, whose objective was to obtain sensitive government information and potentially disrupt or halt operations.

Attack on Voyager Worldwide [27]: In 2022, Voyager Worldwide, a leading maritime technology company, fell victim to a cyber attack that resulted in the complete shutdown of its navigation services and solutions. This major incident affected over 1,000 shipping companies worldwide that rely on Voyager's technology and services.

Ransomware Attack on the Port of Lisbon [136]: The Port of Lisbon suffered a crippling ransomware attack and data breach on Christmas Day 2022. The LockBit group, known for their aggressive tactics, stole a trove of sensitive data including financial reports, cargo information, and ship logs. While the full impact remains unclear, the attack reportedly disrupted port operations and raised concerns about the vulnerability of critical maritime infrastructure. The Port of Lisbon has not publicly commented on the attack or whether they paid the ransom demands of \$1.5 million.

DDoS Attack on London Port Authority Websites [57]: The Port of London Authority (PLA) fell victim to a cyberattack which has knocked its website offline in May 2022. This incident disrupted the normal online operations and services provided by the PLA, impacting its ability to communicate important information, handle inquiries, and facilitate digital transactions.

Ransomware Attack on the Port of Nagoya [112]: In July 2023, the bustling port of Nagoya in Japan faced a crippling ransomware assault orchestrated by the Lockbit group. The cyberattack effectively paralyzed the port's computerized container handling system, halting the flow of incoming shipping containers for a duration of two days.

DP World Australia Attack [104]: In November 2023, DP World, a key player managing 40% of Australia's maritime freight, announced a suspension of operations at its port terminals in Sydney, Melbourne, Brisbane, and Fremantle due to a cybersecurity breach. Responding to the cyber threat, the company took immediate action by isolating its computer systems from external networks, effectively shutting down operations. This resulted in a standstill, with approximately 30,000 shipping containers being left stranded.

4.1.3 Lesson Learned Summary. Researchers at NHL Stenden University in the Netherlands have compiled the Maritime Cyber Attack Database (MCAD) [119], a comprehensive archive documenting over 160 discrete cyber attacks on the maritime transportation sector.

The MCAD reveals an alarming trend: the frequency of maritime cyber incidents have been steadily increasing from 2014 to 2023 (see Figure 6). According to the database, cyber attacks in the maritime sector have targeted a wide array of systems and organizations. These include ship systems like navigation, port infrastructure, shipping companies, maritime authorities, government agencies, shipbuilders, and defense contractors. This diversity of targets highlights the broad attack surface within the maritime industry, spanning from individual vessels to large-scale port operations and regulatory bodies.

As shown in Table 2, maritime cyber incidents have affected numerous countries and regions worldwide, including the United States, European nations (e.g., UK, Germany), Asian countries (e.g., Singapore, Japan), Australia, and Middle Eastern nations like UAE. This global distribution of attacks underscores that maritime cybersecurity is an international concern, with no country or region immune to these threats. The cyber attacks documented span a range of categories, including abuse and theft of data, DoS attacks, GPS spoofing and jamming, malware infections (particularly ransomware), social engineering and phishing attempts, targeted attacks, and exploitation of system vulnerabilities. This attack range shows how diverse the cyberthreats that the maritime industry

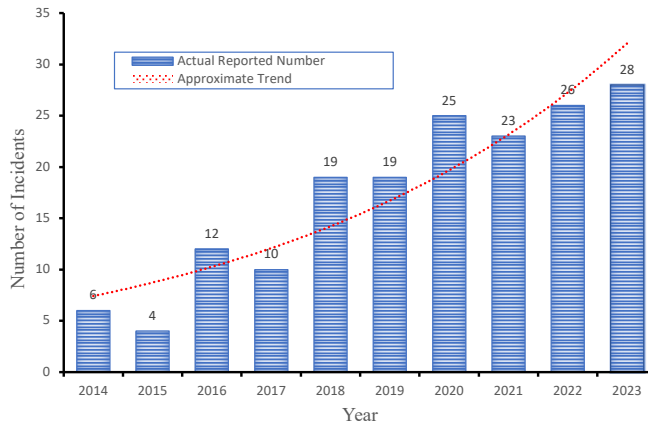

Fig. 6. Maritime cyber incidents by year 2014 - 2023. Recreated by author based on data from MCAD. (<https://maritimecybersecurity.nl/>)

faces are. These attacks are carried out by a similarly varied array of players, including nation-states, hacktivists, cybercriminal organizations, and lone hackers. The threat actors' identities remained a mystery in numerous instances. This diversity of perpetrators suggests that maritime cyberattacks are motivated by a variety of factors.

Table 2. Evaluation of Real-Life Maritime Cyber Attack Incidents

Year	Name	Victim Country	Impact Area	Affected System	Threat Category	Threat Actor	Attack Motivation	Impact	Targeted Principle
2014	Business Email Compromise (BEC) in Dubai	UAE	Shore	E-mail	Social Engineering	Cybercriminal Groups	Financial Gain	Financial Loss	Confidentiality
2015	Targeted Phishing in Limas-sol	Cyprus	Shore	E-mail	Phishing	Cybercriminal Groups	Financial Gain	Financial Loss	Confidentiality
2016	GPS Jamming in South Korea	South Korea	Vessel	GPS	Jamming	Nation-state Actors	Political Objectives	Blocking GPS signal	Availability
2016	Software Flaws in U.S. Ports	USA	Shore	Website	SQL injection attack	Ethical Hacker	Personal Entertainment	View/Modify/Delete Operational Data	Integrity
2017	Navigation System Attack	Germany	Vessel	Navigation System	Hijacking	Cybercriminal Groups	Financial Gain	Unauthorized Control	Availability
2017	Maersk NotPetya Attack	Ukraine	Shore	Network	Malware	Advanced Persistent Threat (APT) Groups	Political Objectives	Financial Loss & Data Contamination	Confidentiality
2017	GPS Spoofing in the Black Sea	Russia	Vessel	GPS	GPS Spoofing	Nation-state Actors	Political Objectives	Wrong GPS Location	Integrity
2018	Port of Barcelona Attack	Spain	Shore	Internal IT Systems	Ransomware	Unknown	N/A	Cargo Delay	Availability
2018	Austal Data Breach	Australia	Shore	Network	Ransomware	Cybercriminal Groups	Financial Gain	Data Theft	Confidentiality
2019	GNSS Spoofing in Port of Shanghai	China	Shore	GNSS	GNSS Spoofing	Nation-state Actors	Reputation	Prevent Smuggling	Integrity
2019	James Fisher and Sons(JFS)	UK	Shore	Network	Ransomware	Cybercriminal Groups	Financial Gain	Reputational Damage	Availability
2020	AIS Spoofing in Polish Waters	USA	Vessel	AIS	AIS Spoofing	Nation-state Actors	Political Objectives	Ghost Ships	Integrity
2021	Death Kitty Ransomware	South Africa	Shore	Network	Ransomware	Cybercriminal Groups	Financial Gain	Operations Halted & Website Down	Availability
2021	Attack on Greek Companies	Greece	Shore	Communication System	Ransomware	Cybercriminal Groups	Financial Gain	Data Loss	Availability
2021	Attack on the Port of Houston	USA	Shore	Network	Zero-day	Nation-state Actors	Political Objectives	Sensitive Data Loss	Confidentiality
2022	Attack on Voyager World-wide	Singapore	Shore	VDR	Hacking	Cybercriminal Groups	Financial Gain	Systems Offline	Availability
2022	Ransomware Attack on the Port of Lisbon	Portugal	Shore	Network	Ransomware	Cybercriminal Groups	Financial Gain	Financial Loss	Availability
2022	DDoS Attack on London Port Authority Websites	UK	Shore	Website	DDoS	Hacktivists	Political Objectives	Website Down	Availability
2023	Ransomware Attack on the Port of Nagoya	Japan	Shore	Network	Ransomware	Cybercriminal Groups	Sabotage	Operations Halted	Availability
2023	DP World Australia Attack	Australia	Shore	Network	Hacking	Cybercriminal Groups	Financial Gain	Data Theft	Availability

4.2 Cyber Attack Demonstrations (Academic)

Academic cyber attack demonstrations typically take place in simulated environments or self-developed software that replicate maritime systems and networks. There are also a portion of academic research focuses on theoretically feasible attacks by modeling maritime systems to identify potential attack vectors, even if they haven't been practically implemented in a full-scale simulation. These demonstrations often focus on specific components of maritime systems.

AIS Threats Overview Balduzzi *et al.* [14] conducted a comprehensive security evaluation of the AIS and categorized these threats into three main types: i) spoofing, ii) hijacking, and iii) availability disruption attacks. Kessler *et al.* [91] presented a comprehensive analysis of the potential cyber threats to the AIS by drawing upon previous research [55][133][151] that examined the vulnerabilities of Automatic Dependent Surveillance-Broadcast (ADS-B), a similar system used in the aviation industry to provide situational awareness for aircraft. Amro and Gkioulos [8] discussed a novel cyber attack that utilizes the AIS as a covert channel for sending command and control messages and delivering malware to maritime systems.

VDR Threats Overview Harish *et al.* [69] launched a multi-pronged attack on a commercially available VDR, employing a USB Rubber Ducky for physical infiltration, the Metasploit framework for system exploit, a ransomware simulator to demonstrate data encryption risks, and Nmap to identify exploitable network vulnerabilities. Hopcraft *et al.* [76] highlighted cybersecurity deficiencies in current VDR systems and standards, and presented they are susceptible to ransomware attacks, malware infections, denial-of-service (DoS) attacks, insider threats and data breaches. Söner *et al.* [147] used failure modes and effects analysis (FMEA) to assess cyber vulnerabilities and potential attacks against VDR. Data acquisition unit (DAU) is found to be the most vulnerable VDR component, followed by remote access solutions and the bridge control panel. False data injection, command injection, and viruses are ranked as the top three threats in the FMEA risk assessment.

RADAR Threats Overview Junior *et al.* [102] demonstrated how the attacker could send the command to the ship's radar via an electronic attack (EA) that generates false radar echoes in a specific pattern. Wolsing *et al.* [168] presented a taxonomy of possible network cyber attacks on marine RADAR and a simulation environment to implement these attacks. The taxonomy covers denial of service attacks, attacks involving basic image transformations like scaling, rotation and translation, and targeted object manipulations like addition, removal and relocation of radar echoes. Longo *et al.* [111] demonstrated that it is feasible to develop malware that can autonomously and stealthily target radar systems on ships by exploiting vulnerabilities in standard protocols like NMEA and ASTERIX that lack authentication and encryption. Longo *et al.* [109] discussed a novel threat model that combines cyber attacks with cyber false flags to target maritime RADAR systems. The proposed cyber attacks manipulate RADAR data to simulate the effects of electronic countermeasures (ECM) like barrage jamming, spot jamming, digital radio frequency memory, and blip enhancement. By making the cyber attacks appear as ECM originating from another ship, it creates a false flag that misleads attribution of the attack. These false flag attacks aim to disrupt radar operations, divert blame, hide the cyber nature of the attack, and project the attacker's offensive capabilities.

VSAT Threats Overview Santamarta [139] discussed security vulnerabilities found in various widely deployed satellite communications (SATCOM) terminals and described several real-world attack scenarios showing how these flaws could be exploited to leak sensitive military data, interfere with distress communications, spoof navigation data, disable safety systems, and more. Based on the two scenarios presented, VSAT systems in the maritime context face threats of data manipulation, spoofing, and communication disruption. Pavur *et al.* [128] revealed serious security flaws in how maritime VSAT networks are currently implemented. The insecure VSAT links could allow attackers

to modify important data like ECDIS navigational charts and AIS vessel tracking information, impacting ship safety. Under certain conditions, an attacker could hijack active TCP sessions and modify data in real-time.

GNSS Threats Overview Grant *et al.* [63] conducted practical experiments to validate the threat of GPS jamming on maritime navigation. Bhatti and Humphreys [19] analyzed and demonstrated the ability of an attacker to control a maritime surface vessel by broadcasting counterfeit civil GPS signals. Medina *et al.* [115] carried out a dedicated jamming measurement campaign on the Baltic Sea in cooperation with the German Federal Network Agency.

ECDIS Threats Overview All five papers written by Svilicic *et al.* [154–158] focused on the cyber security aspects of the ECDIS and used similar vulnerability scanning methods. However, each paper had a unique focus. Svilicic *et al.* [154] presented an estimation of the cyber security vulnerabilities of ECDIS that arise from weaknesses related to the underlying operating system. Svilicic *et al.* [155] introduced a framework for assessing cyber risks of the ship's critical systems and assets. Svilicic *et al.* [156] identified the main threats to the ECDIS system through a survey of the ship's crew and computational vulnerability scanning using Nessus Professional software. Svilicic *et al.* [157] highlighted that interconnecting multiple ECDIS workstations with the same vulnerabilities provides an ideal environment for malware to spread. Svilicic *et al.* [158] emphasized on the cyber security weaknesses of a ECDIS arising from the software's third-party components. Dyravyy [47] discussed the cyber security risks and weaknesses within ECDIS and the research revealed that a malicious actor could potentially browse, download, modify, or erase any file on the computer running the ECDIS software [71].

GMDSS Threats Overview While specific GMDSS cyber attack examples are limited, the concepts of jamming, spoofing and DoS [3][160] discussed could all theoretically be used to disrupt GMDSS functionality as ships become more networked and vulnerable to cyber threats. The authors [160] also discussed the risk of malware infections in ship systems. While not specifically mentioning GMDSS, such an attack could potentially affect GMDSS equipment if it's connected to infected systems.

5 SECURITY SOLUTIONS

5.1 Integrated or Holistic

Rather than focusing on individual components, integrated solutions aim to create a comprehensive framework that protects and optimizes the vessel as a whole. For example, an integrated solution might include a centralized security operations center that monitors and manages threats across all vessel systems, from navigation and communication to cargo management and environmental controls. Integrated solutions frequently leverage advanced technologies like machine learning algorithms to analyze data from various shipboard systems, identifying patterns that could indicate potential security breaches or safety risks before they escalate into serious problems.

5.1.1 Machine/Deep Learning-Based Defence. The demonstrated performance and adaptability of some advanced deep learning techniques suggest significant potential for their practical application in safeguarding critical maritime infrastructure against the ever-evolving landscape of cyber threats. In [97], it was revealed that the DLTF framework exhibited superior performance in automatically extracting and identifying cyber threat patterns compared to traditional machine learning approaches across multiple evaluation metrics. Dual Stack Machine Learning (S2ML) framework is proposed in [5] which takes a novel approach by leveraging entropy-based features extracted from network traffic, a method that proves particularly effective in identifying anomalies indicative of DDoS attacks. Similarly, the authors of [66] leveraged the capabilities of an adaptive

incremental passive-aggressive machine learning (AI-PAML) which is designed to continuously update its learning model as new network attacks are detected.

While DLTF, S2ML and AI-PAML focus on identifying or detecting threats, the Multi-Agent Reinforcement Learning (MARL) [167] approach takes the next step by exploring how AI can be used to actively defend against these threats. The MARL solution establishes a simulation environment for training autonomous cyber defence agents for maritime operational technology (OT) to enhance the resilience of maritime control systems.

5.1.2 Cryptographic Schemes. The distributed nature of maritime systems, with ships, ports, and other infrastructure being geographically dispersed, renders centralized security solutions impractical. Recent research has proposed several cryptographic schemes that provide security in a distributed manner, employing techniques such as symmetric encryption, attribute-based encryption, erasure coding, identity-based encryption, and digital signatures to enable each entity to safeguard its own data and communications. A lightweight authentication protocol [28] using symmetric cryptography primitives like XOR and hash operations can provide mutual authentication and shared key establishment while ensuring vessel privacy. Similarly, an attribute-based secure data aggregation scheme [163] employs constant attributes of maritime terminals for authentication and onboard sensors for data encryption, using zero-knowledge proofs for member certification. Addressing a critical aspect of maritime data security overlooked by the previous schemes, it was proposed that a flexible integrity checking and recovery mechanism [106] is particularly valuable in maritime environments where harsh conditions frequently lead to data corruption. Other prevention methods include an identity-based authentication mechanism [65] that integrates both cryptographic techniques and distributed ledger technologies to ensure not only the confidentiality and integrity of data but also enhance transparency and non-repudiation in maritime communications.

The prevalence of legacy equipment in maritime communication channels, often predating modern security protocols and persisting due to extended lifecycles, presents significant cybersecurity vulnerabilities in today's interconnected maritime environment. In order to offer a pragmatic strategy for a gradual, cost-effective transition towards more secure maritime communication paradigms, the authors of [73] proposed the SIGMAR framework, which extends the IEC 61162-450 protocol and integrates the Elliptic Curve Digital Signature Algorithm (ECDSA) to provide robust authentication and integrity verification with minimal latency and communication overhead.

5.1.3 Blockchain-Based Defence. A secure communication framework can be harnessed by introducing a private blockchain network integrated with a terrestrial fusion center for authentication purposes [134]. The approach is designed to provide a resilient and trustworthy communication infrastructure for maritime systems, with particular emphasis on unmanned aerial vehicle (UAV)-assisted sensing applications in maritime environments. In [178], a blockchain-based authentication mechanism is utilized to store and validate the identities of vessels and IoT devices. The solution implements a proof-of-authority consensus mechanism and incorporates a threshold-based approach for detecting malicious nodes. Further, blockchain can be used to secure positioning data in maritime environments. A blockchain-based privacy preserving position data sharing approach is leveraged in [52] to address the critical privacy challenges in maritime IoT systems.

By harnessing the immutability and distributed nature of blockchain technology, these kind of techniques aim to mitigate security vulnerabilities inherent in traditional centralized systems, while accommodating the unique challenges posed by maritime IoT ecosystems.

5.1.4 Network Level-Based Defence. Maritime vessels are equipped with systems of varying criticality levels [135], with navigation and propulsion systems being mission-critical, in contrast to the

non-essential nature of crew entertainment systems. A zone-based network segmentation approach, dividing ships' network into isolated zones like the Global Ship Zone, Ship Control Zone, and Ship System Zone, is proposed in [51] that help contain potential threats and prevent them from spreading to other critical areas. Further, a cyber attack path discovery method [130] for maritime risk management can be used to identify potential vulnerabilities in network configurations.

In [72], it was suggested that creating and maintaining whitelists of authorized devices and their permissions could provide a strong, regular security check for the local network environment of maritime IoT devices against DNS rebinding attacks.

5.1.5 Miscellaneous / Hybrid. Security solutions for maritime threats do not fit neatly into the sole categories of machine/deep learning, blockchain, network level or cryptographic approaches but rather integrate various methods to achieve their goals. A rule-based risk model [49] utilizing geospatial analysis, anomaly detection, and statistical methods is introduced to generate risk maps and real-time alerts, aimed at detecting abnormal behaviors indicative of maritime attacks. The ISOLA project [100] integrates a broad spectrum of technologies and methodologies, including sensor networks, data fusion, semantic reasoning, and visual analytics, while incorporating cyber vulnerability assessment tools and decision support systems to aid security personnel in identifying and responding to potential threats in the cruise ship industry. Chen and Wu [31] combined various technologies such as AIS, deep learning and cryptographic schemes to address multiple issues in maritime such as data integrity, authentication and network security.

5.2 Component Specific

Component-specific solutions refer to targeted countermeasures or protective measures designed to address vulnerabilities or prevent threats associated with particular vessel components. These solutions are tailored to the unique characteristics and vulnerabilities of each component, taking into account its function, exposure to threats, and critical role in the vessel's overall operation. Component-specific solutions often involve specialized hardware, software, or operational procedures to provide deep, focused protection for critical components.

5.2.1 AIS Countermeasures. Kowalska and Peel [96] presented an approach for detecting anomalous vessel behaviour using Gaussian Process (GP) models trained on AIS data. The GP anomaly detection method focuses on identifying suspicious vessel behaviors rather than securing the communication channel or data itself. Balduzzi *et al.* [14] recommended applying anomaly detection techniques to the AIS data to identify suspicious activities, such as unexpected changes in a vessel's route, which could indicate spoofing or hijacking attempts. The author [14] also suggested to implement a Public Key Infrastructure (PKI) using X.509 certificates to enable authentication and integrity checks for AIS messages. Iphar *et al.* [84] outlined a conceptual methodology for using various data quality dimensions to assess the integrity and trustworthiness of information within AIS messages. Su *et al.* [152] proposed authentication and privacy-preserving enhancements to the AIS protocol to address the security vulnerabilities that currently allow identity spoofing and enable tracking of vessels through their AIS broadcasts. They first introduced Digital Signature based Identity Authentication Scheme (DSIAS) to prevent tampering or forging of vessel identities and then proposed Mix-zone based Trajectory Privacy Protection Scheme (MTPPS) to provide anonymity of vessel trajectories. They further built a Blind-signature extension to the MTPPS, which provides an additional layer of privacy. Kontopoulos *et al.* [94] advocated an architectural solution for detecting malicious tampering of live AIS data streams. Goudossis and Katsikas [61] explored how a Maritime Certificate-less Identity-Based Public Key Cryptography (mIBC) infrastructure may enhance the security properties of AIS. While the previous paper introduced the concept of using Identity-Based cryptography to secure AIS, Goudossis and Katsikas [62] further delved into the implementation

details, introduced a new application for seamless integration with the existing AIS infrastructure, and provided operational overhead estimates. Nguyen [117] evaluated the AIS architecture and explored using lightweight cryptographic algorithms to design an optimal authentication system. Sciancalepore *et al.* [143] focused on the design, security properties, implementation and performance evaluation of the proposed Auth-AIS protocol to secure vessel AIS broadcast messages in a practical manner. Kelly [90] used Received Signal Strength Indicator (RSSI) based detection method to enhance AIS security by providing a means to identify and investigate vessels attempting to exploit the low power mode to evade tracking, which could indicate involvement in illicit activities. Deng *et al.* [43] proposed a novel lightweight Transformer-based network called GLFormer for specific emitter identification (SEI) to provide an extra security layer for AIS terminal emitters.

The maritime environment should necessitate caution when applying GPS research findings from other domains without targeted validation. Signal propagation patterns, interference sources, and operational requirements can differ substantially between land-based and maritime settings, potentially limiting the direct transferability of results. To assure the applicability and reliability of findings in GNSS threats and defenses, this study has prioritised the research that has conducted experiments and analyses in representative maritime conditions.

5.2.2 GNSS Countermeasures. Grant *et al.* [63] tested the feasibility of eLoran as a backup system to provide PNT during GPS jamming incidents. Bhatti and Humphreys [19] proposed several countermeasures to mitigate the risk of GPS spoofing attacks on maritime vessels. In contrast, Drumhiller *et al.* [46] focused on primary defenses against GPS jamming. Medina *et al.* [115] proposed jamming countermeasures like robust signal processing, adaptive antenna arrays, or multi-sensor fusion. A new technique for detecting GNSS spoofing attacks using signals from the Iridium satellite constellation was proposed by Oligeri *et al.* [121]. Spravil *et al.* [148] focused on detecting GPS spoofing attacks in the maritime domain using a novel software-based framework called MANA (MARitime Nmea-based Anomaly detection). Boudehenn *et al.* [25] proposed a strategy to enhance the detection of navigation spoofing attacks and assess possible physical impacts.

5.2.3 ECDIS Countermeasures. Based on the information provided by Svilicic *et al.* and Dyravyvy, some mitigation measures can be implemented to enhance the security of ECDIS systems. While the papers [47][154–158] offer valuable insights into ECDIS threats and propose mitigation measures, the authors did not include experiments specifically designed to test the effectiveness of those mitigation. These theoretical measures can be categorized into technical, procedural, and organizational aspects.

5.2.4 RADAR Countermeasures. Various security solutions and mitigation measures have been developed to protect RADAR systems, both in general and for specific applications, although they are not exclusive to the maritime domain. These include deep learning-based anomaly detection techniques [39][42], hash-based integrity checks and encryption designed for the ASTERIX protocol [26], and algorithmic approaches [172]. Despite the existence of these security solutions, it can be challenging to directly apply them to the maritime scenarios [168]. The unique characteristics and requirements of marine RADAR systems should necessitate tailored approaches to ensure effective security measures. Junior *et al.* [102] briefly mentioned that as future work, they may develop tools to verify the integrity of the software used in naval RADAR systems, in order to detect any malicious code or malware that may have been pre-installed in the RADAR. Longo *et al.* [111] proposed a detection system as a countermeasure to the marine RADAR attacks. It is designed as a policy enforcement system where the policies dictate how the RADAR should operate according to industry standards, regulations, and manufacturer specifications, in conjunction with onboard

configurations. The experimental results demonstrate that the detection system proposed in this study consumes fewer resources while detecting these attacks with high accuracy.

5.2.5 VDR Countermeasures. Söner *et al.* [147] also recommended several preventive and control measures to improve the cybersecurity of VDR based on their FMEA risk assessment findings. They emphasized that while cyberattacks cannot be entirely prevented due to the nature of the cyber world, their effects can be mitigated by conducting cyber risk assessments and implementing effective control measures to safeguard VDR from current and emerging cybersecurity threats. The authors [76] also proposed several amendments to the standards to improve VDR security.

5.2.6 VSAT Countermeasures. The author [128] acknowledged that some of these solutions, such as end-to-end encryption, may have performance implications due to the high latency of satellite communications. However, they emphasized the need for the maritime industry to prioritize security and invest in the development of practical, satellite-optimized security measures to protect ships, crew, and cargo from potential cyber threats. Wu *et al.* [170] proposed a new lightweight authentication scheme called lite-CA (Lite Certification Authority) to reduce the amount of interaction required for authentication within the VSAT network architecture. To achieve real-time data encryption, they further proposed using a lightweight encryption algorithm called HW-F (high weight function) to replace traditional public key and symmetric encryption systems.

5.2.7 GMDSS Countermeasures. Korcz [95] discussed the ongoing modernization of GMDSS which includes introduction of new satellite providers beyond Inmarsat (e.g. Iridium and Beidou), development of the VHF Data Exchange System (VDES) for improved data communication and implementation of digital broadcasting of maritime safety information. These measures could provide more secure and efficient data exchange and enhance GMDSS communications. Osés and Juncadella [113] argued that it is conceptually and technologically feasible to create a global VTS system as a counterpart to GMDSS.

6 OPEN CHALLENGES

Maritime environments present unique challenges that are often overlooked in current cybersecurity literature. This section highlights several lesser-discussed issues that significantly impact the maritime sector's cybersecurity landscape.

6.1 Device heterogeneity

Maritime devices operate in a wide range of environments, ranging from bustling ports and dynamic coastal areas to the vast expanses of open seas. The diversity of maritime environments requires a corresponding diversity in device types. While this heterogeneity presents challenges for manufacturers and operators alike – including issues related to standardization and interoperability – it also ensures that appropriate technologies can be effectively deployed across various maritime scenarios. The maritime industry is facing an increasing demand for improved operational visibility at sea [165]. Enhanced operational visibility at sea contributes to overall safety by providing early detection of anomalies or hazards that could pose a threat to crew members or the environment. Maritime IoT addresses this requirement by making it possible to monitor vital indicators like fuel usage, machinery performance, and general vessel operations in real time. As a result, maritime stakeholders are able to make more informed decisions, optimize resource utilization, and improve overall efficiency and safety. However, the implementation of maritime IoT presents complexities. The system must accommodate a wide range of machine-type communication devices, from low-cost units with limited functionality to high-end devices offering advanced features [165]. Low-cost devices such as sensors and buoys often operate under power and energy constraints, posing

challenges in selecting appropriate communication technologies and protocols that prioritize energy efficiency and longevity over high data rates or complex functionalities [165]. To address these challenges posed by device heterogeneity, edge computing and cloud-based solutions have been proposed [44]. While cloud-based solutions and edge computing offer valuable tools for managing device heterogeneity in maritime IoT, cloud solutions require reliable internet connections, which may not always be available in open seas where face connectivity issues [93]. In addition, implementing both cloud and edge solutions adds another layer of complexity to an already complex system of heterogeneous devices.

6.2 Rapid technology evolution v.s. Slow-paced shipping industry

The slow pace of technological adoption in the global shipping fleet is evident in the statistics: only 0.3% of operating vessels worldwide have implemented alternative energy solutions, with this figure rising slightly to 6.05% for ships currently on order [149]. This sluggish uptake is largely due to the long operational lifespan of vessels, typically 25-30 years, which creates significant inertia in the industry. Upgrading existing ships or investing in new builds with advanced technologies requires substantial capital, making fleet-wide changes extremely costly and time-consuming [150]. The capital-intensive nature of these investments leads to a lock-in effect, where shipping companies are hesitant to abandon existing technologies before fully depreciating their assets. This economic reality is compounded by the slow pace of regulatory change in the industry. For instance, despite recognizing the need to address greenhouse gas (GHG) emissions in the 1990s, the IMO did not adopt its first strategy for GHG reduction until 2018 [149]. The combination of long vessel lifespans, high capital costs, and a slow-moving regulatory environment creates a gap between the rapid evolution of new technologies and their implementation in the shipping industry.

6.3 A culture of secrecy

The maritime industry grapples with a unique challenge regarding cybersecurity incident transparency and information sharing. In stark contrast to the aviation sector, which has cultivated a culture of open reporting and collaborative information exchange on safety and security matters, the maritime domain often shrouds cyber incidents in secrecy, primarily due to concerns about reputational damage [118]. In the United States alone, at least eighteen federal agencies have responsibility for regulating various aspects of maritime transportation, with little to no formal methods of coordinating their efforts. This regulatory fragmentation contributes to the "highly fragmented" and "near chaotic" nature of the maritime domain. This lack of coordination potentially discourages transparent reporting, and this may hinder the industry's collective ability to learn from past incidents and implement effective preventive measures against future cyber threats. Moreover, the opaque nature of maritime operations and regulations poses additional obstacles. For instance, it impedes the development of crucial technologies such as autonomous collision avoidance systems [162], thereby stunting the overall advancement of maritime technology. Overcoming this ingrained secrecy to foster greater transparency and information sharing will require significant shifts in industry practices, regulations, and mindsets. Key stakeholders must recognize that the benefits of shared knowledge and collaborative security efforts far outweigh the perceived risks of disclosure. True security lies not in secrecy, but in transparency.

6.4 Limitations of technological solutions

As previously discussed, while technologies such as blockchain, machine learning, and artificial intelligence show promise in addressing maritime cybersecurity challenges, they are not panaceas. Each technology comes with its own set of limitations, including scalability issues, susceptibility to new forms of attacks, and integration difficulties with existing systems. For example, the global

scale and complexity of maritime supply chains strain blockchain's scalability and processing speed, potentially slowing down operations in an industry where time is critical [103]. It is essential for the maritime industry to approach these technologies critically, recognizing both their potential benefits and inherent constraints. Additionally, rather than relying solely on a single advanced technology, a more effective strategy involves implementing a multi-layered technological approach. This may entail combining various technologies to establish a stronger defense. For instance, utilizing AI for threat detection, blockchain for secure data sharing, and quantum-resistant cryptography for future-proofing communications. This layered approach can help mitigate the weaknesses of individual technologies. Overall, while advanced technologies hold promise for enhancing cybersecurity in the maritime sector, it is crucial to carefully evaluate their capabilities and limitations before implementation.

7 FUTURE DIRECTIONS

While the maritime industry's future encompasses numerous potential directions, this section focuses on current trending topics and areas undergoing active implementation. These selected future directions are expected to significantly reshape the maritime security landscape.

7.1 Maritime Cloud

The maritime cloud concept is currently in its formative stages, with ongoing projects and evolving implementations shaping its development. Park [127] mentioned that the maritime cloud is closely tied to the development of e-Navigation, a strategic initiative spearheaded by the IMO to harmonize and enhance navigation systems globally. The integration of the maritime cloud with e-Navigation strategies could offer a opportunity to facilitate seamless information exchange across diverse maritime stakeholders. It has the potential to transcend the limitations of specific communication systems or channels, creating a unified platform that connects vessels, ports, coastal authorities and other maritime actors. Cloud technology offers numerous other advantages in the maritime domain, including enhanced data management [40], improved maritime safety and security with distributed smart surveillance systems [101], cost reduction [137], system compatibility [127], and real-time monitoring of vessel positions and status [86]. Despite these promising applications, further research is imperative across multiple domain within maritime cloud computing, such as security concerns in cloud implementation [24].

7.2 Testbeds

Maritime-specific cybersecurity testbeds can be used to simulate cyber attacks on ship systems, allowing for the development and testing of defense mechanisms without risking actual vessels or infrastructure. In response to the growing need for advanced testing and research capabilities in the maritime sector, several notable testbeds have been established worldwide. The eMaritime Integrated Reference Platform (eMIR) [67], developed in Germany, combines both virtual and physical components for providing a robust environment to test maritime cyber-physical systems. In the United Kingdom, the University of Plymouth hosts the Cyber-SHIP Lab [159], a specialised facility for researchers to carry out cyber attack experiments. Meanwhile, in Singapore, the Singapore Polytechnic houses the Advanced Navigation Research Simulator (ANRS) [120], which is designed to support maritime training and education. Existing testbeds rely heavily on simulation rather than real maritime hardware, as physical testbeds incorporating actual maritime equipment are costly to construct and maintain [171][179]. Each testbed architecture has its distinct advantages and limitations. Virtual testbeds enable testing of potentially dangerous scenarios without risking damage to physical equipment or endangering personnel [110]; however, they often struggle to accurately replicate wireless communications [7], which are crucial in maritime settings. There's a

need for a balance between virtual and physical components to achieve greater realism in maritime testbeds. While current testbeds are valuable, we believe they require continued investment and innovation to better support the evolving needs of the maritime industry.

8 CONCLUSION

This review underscores the complexity of securing maritime systems and emphasized the importance of a multi-faceted approach that combines technological innovation, regulatory frameworks, and cultural shifts within the industry. While promising solutions like AI-driven threat detection and blockchain-based authentication offer new defensive capabilities, they must be implemented thoughtfully to address the unique challenges of the maritime environment. Moving forward, the development of maritime-specific cybersecurity testbeds, the evolution of the maritime cloud, and increased transparency in incident reporting will be crucial in building a more secure and resilient global maritime infrastructure. As the industry continues to navigate these digital waters, collaboration between stakeholders, adaptive regulatory frameworks, and continuous research will be essential in safeguarding the future of maritime operations against ever-evolving cyber threats.

ACKNOWLEDGMENTS

The authors declare no conflict of interest. This research is supported by the National Research Foundation, Singapore (NRF), Maritime and Port Authority of Singapore (MPA) and Singapore Maritime Institute (SMI) under its Maritime Transformation Programme (Project No. SMI-2022-MTP-04). Any opinions, findings and conclusions or recommendations expressed in this material are those of the author(s) and do not reflect the views of NRF, MPA and SMI.

REFERENCES

- [1] Ahmed Hany M Abuelenin. 2017. The impact of shortage implementation of the international regulations on maritime safety. *Cogent social sciences* 3, 1 (2017), 1335499.
- [2] NPH Adams, RJ Chisnall, C Pickering, and S Schauer. 2020. How port security has to evolve to address the cyber-physical security threat: lessons from the SAURON project. *International Journal of Transport Development and Integration* 4, 1 (2020), 29–41.
- [3] Frank Akpan, Gueltoum Bendiab, Stavros Shiaeles, Stavros Karamperidis, and Michalis Michaloliakos. 2022. Cybersecurity challenges in the maritime sector. *Network* 2, 1 (2022), 123–138.
- [4] Juan Ignacio Alcaide and Ruth Garcia Llave. 2020. Critical infrastructures cybersecurity and the maritime sector. *Transportation Research Procedia* 45 (2020), 547–554.
- [5] Farhan Ali, Sohail Sarwar, Qaisar M Shafi, Muddesar Iqbal, Muhammad Safyan, and Zia Ul Qayyum. 2022. Securing IoT based maritime transportation system through entropy-based dual-stack machine learning framework. *IEEE Transactions on Intelligent Transportation Systems* 24, 2 (2022), 2482–2491.
- [6] Fahad S Alqurashi, Abderrahmen Trichili, Nasir Saeed, Boon S Ooi, and Mohamed-Slim Alouini. 2022. Maritime communications: A survey on enabling technologies, opportunities, and challenges. *IEEE Internet of Things Journal* 10, 4 (2022), 3525–3547.
- [7] Ahmed Amro and Vasileios Gkioulos. 2021. Communication and cybersecurity testbed for autonomous passenger ship. In *European Symposium on Research in Computer Security*. Springer, 5–22.
- [8] Ahmed Amro and Vasileios Gkioulos. 2022. From click to sink: Utilizing ais for command and control in maritime cyber attacks. In *European Symposium on Research in Computer Security*. Springer, 535–553.
- [9] M Ashour. 2013. The Influence on Safety at Sea from the Voyage Data Recorder (VDR). *International Journal of Multidisciplinary and Current Research* 3, 5 (2013), 955–960.
- [10] Imran Ashraf, Yongwan Park, Soojung Hur, Sung Won Kim, Roobaea Alroobaea, Yousaf Bin Zikria, and Summera Nosheen. 2022. A survey on cyber security threats in iot-enabled maritime industry. *IEEE Transactions on Intelligent Transportation Systems* 24, 2 (2022), 2677–2690.
- [11] Malik Shahzad Kaleem Awan and Mohammed A Al Ghamdi. 2019. Understanding the vulnerabilities in digital components of an integrated bridge system (IBS). *Journal of Marine Science and Engineering* 7, 10 (2019), 350.
- [12] Philip Bader. 2021. *GREEK SHIPPING SOFTWARE HIT BY RANSOMWARE*. Retrieved May 27, 2024 from <https://www.securedata.com/blog/greek-shipping-software-hit-by-ransomware/#top>

- [13] Al-Amin Baksh, Rouzbeh Abbassi, Vikram Garaniya, and Faisal Khan. 2018. Marine transportation risk assessment using Bayesian Network: Application to Arctic waters. *Ocean Engineering* 159 (2018), 422–436.
- [14] Marco Balduzzi, Alessandro Pasta, and Kyle Wilhoit. 2014. A security evaluation of AIS automated identification system. In *Proceedings of the 30th annual computer security applications conference*. 436–445.
- [15] Austin H Becker, Michele Acciaro, Regina Asariotis, Edgar Cabrera, Laurent Creteigny, Philippe Crist, Miguel Esteban, Andrew Mather, Steve Messner, Susumu Naruse, et al. 2013. A note on climate change adaptation for seaports: a challenge for global ports, a challenge for global society. *Climatic change* 120 (2013), 683–695.
- [16] Mohamed Amine Ben Farah, Elochukwu Ukwandu, Hanan Hindy, David Brosset, Miroslav Bures, Ivan Andonovic, and Xavier Bellekens. 2022. Cyber security in the maritime industry: A systematic survey of recent advances and future trends. *Information* 13, 1 (2022), 22.
- [17] Nora Berg, Jenni Storgård, and Jouni Lappalainen. 2013. The impact of ship crews on maritime safety. *Publications of the Centre for Maritime Studies, University of Turku A* 64 (2013), 1–48.
- [18] Bjorn Bergman. 2021. *Systematic data analysis reveals false vessel tracks*. Retrieved May 27, 2024 from <https://skytruth.org/2021/07/systematic-data-analysis-reveals-false-vessel-tracks/>
- [19] Jahshan Bhatti and Todd E Humphreys. 2017. Hostile control of ships via false GPS signals: Demonstration and detection. *NAVIGATION: Journal of the Institute of Navigation* 64, 1 (2017), 51–66.
- [20] BIMCO. 2016. *The guidelines on cyber security onboard ships*. Bimco.
- [21] Holly Birkett. 2015. *Hackers steal \$644,000 from a Cyprus shipping company*. Retrieved May 27, 2024 from <https://splash247.com/hackers-steal-644000-from-a-cyprus-shipping-company/>
- [22] Tanya Blake. 2017. *Hackers took 'full control' of container ship's navigation systems for 10 hours – IHS Fairplay*. Retrieved May 27, 2024 from <https://rntfnd.org/2017/11/25/hackers-took-full-control-of-container-ships-navigation-systems-for-10-hours-ihs-fairplay/>
- [23] Dennis Bothur, Guanglou Zheng, and Craig Valli. 2017. A critical analysis of security vulnerabilities and countermeasures in a smart ship system. (2017).
- [24] Ive Botunac, Juraj Poljak, and Dino Županović. 2017. Analysis of the security challenge in maritime cloud computing. *Book of* (2017), 256.
- [25] Clet Boudehenn, Olivier Jacq, Maxence Lannuzel, Jean-Christophe Cexus, and Abdel Boudraa. 2021. Navigation anomaly detection: An added value for maritime cyber situational awareness. In *2021 International Conference on Cyber Situational Awareness, Data Analytics and Assessment (CyberSA)*. IEEE, 1–4.
- [26] Eduardo Esteban Casanovas, Tomas Exequiel Buchailot, and Facundo Baigorria. 2015. Vulnerability of radar protocol and proposed mitigation. In *2015 ITU Kaleidoscope: Trust in the Information Society (K-2015)*. IEEE, 1–6.
- [27] Sam Chambers. 2022. *Voyager Worldwide hit by cyber attack*. Retrieved May 27, 2024 from <https://splash247.com/voyager-worldwide-hit-by-cyber-attack/>
- [28] Shehzad Ashraf Chaudhry, Azeem Irshad, Muhammad Asghar Khan, Sajjad Ahmad Khan, Summera Nosheen, Ahmad Ali AlZubi, and Yousaf Bin Zikria. 2021. A lightweight authentication scheme for 6G-IoT enabled maritime transport system. *IEEE Transactions on Intelligent Transportation Systems* 24, 2 (2021), 2401–2410.
- [29] Christine Chauvin. 2011. Human factors and maritime safety. *The Journal of Navigation* 64, 4 (2011), 625–632.
- [30] Christine Chauvin, Salim Lardjane, Gaël Morel, Jean-Pierre Clostermann, and Benoît Langard. 2013. Human and organisational factors in maritime accidents: Analysis of collisions at sea using the HFACS. *Accident Analysis & Prevention* 59 (2013), 26–37.
- [31] Mu-Yen Chen and Hsin-Te Wu. 2022. An automatic-identification-system-based vessel security system. *IEEE Transactions on Industrial Informatics* 19, 1 (2022), 870–879.
- [32] Yuli Chen, Naiyuan Lou, Guangli Liu, Yang Luan, and Han Jiang. 2022. Risk analysis of ship detention defects based on association rules. *Marine Policy* 142 (2022), 105123.
- [33] Sungbaek Cho, Erwin Orye, Gabor Visky, and Vasco Prates. 2022. Cybersecurity Considerations in Autonomous Ships. *NATO Cooperative Cyber Defence Centre of Excellence: Tallinn, Estonia* (2022).
- [34] Kenneth Christopher. 2009. *Port security management*. Auerbach Publications.
- [35] Ahmet Yunus Cil, Dini Abdurrahman, and Ibrahim Cil. 2022. Internet of Things enabled real time cold chain monitoring in a container port. *Journal of Shipping and Trade* 7, 1 (2022), 9.
- [36] Catalin Cimpanu. 2016. *US Ports Targeted with Zero-Day SQL Injection Flaw*. Retrieved May 27, 2024 from <https://news.softpedia.com/news/us-ports-targeted-with-zero-day-sql-injection-flaw-507566.shtml>
- [37] ISPS Code. 2016. *International Ship and Port Facility Security Code*.
- [38] Shai Cohen, Tomer Gluck, Yuval Elovici, and Asaf Shabtai. 2019. Security analysis of radar systems. In *Proceedings of the ACM Workshop on Cyber-Physical Systems Security & Privacy*. 3–14.
- [39] Shai Cohen, Efrat Levy, Avi Shaked, Tair Cohen, Yuval Elovici, and Asaf Shabtai. 2022. RadArnomaly: Protecting radar systems from data manipulation attacks. *Sensors* 22, 11 (2022), 4259.

- [40] Dragos Sebastian Cristea, Liliana Mihaela Moga, Mihaela Neculita, Olegas Prentkovskis, Khalil Md Nor, and Abbas Mardani. 2017. Operational shipping intelligence through distributed cloud computing. *Journal of Business Economics and Management* 18, 4 (2017), 695–725.
- [41] Ry Crozier. 2020. *Shipbuilder Austal was hacked with stolen creds sold on dark web*. Retrieved May 27, 2024 from <https://www.itnews.com.au/news/shipbuilder-austal-was-hacked-with-stolen-creds-sold-on-dark-web-546165>
- [42] Theobald de Riberolles, Yunkai Zou, Guthemberg Silvestre, Emmanuel Lochin, and Jiefu Song. 2022. Anomaly detection for ICS based on deep learning: a use case for aeronautical radar data. *Annals of Telecommunications* 77, 11 (2022), 749–761.
- [43] Pengfei Deng, Shaohua Hong, Jie Qi, Lin Wang, and Haixin Sun. 2023. A lightweight transformer-based approach of specific emitter identification for the automatic identification system. *IEEE Transactions on Information Forensics and Security* (2023).
- [44] JP Dhivvyva, Sethuraman N Rao, and S Simi. 2017. Towards maximizing throughput and coverage of a novel heterogeneous maritime communication network. In *Proceedings of the 18th ACM International Symposium on Mobile Ad Hoc Networking and Computing*. 1–2.
- [45] Giuseppe Di Bucchianico, Andrea Vallicelli, Neville A Stanton, and Steven J Landry. 2016. *Human factors in transportation: social and technological evolution across maritime, road, rail, and aviation domains*. CRC Press.
- [46] N.K. Drumhiller, J. DiRenzo, and F.S. Roberts. 2017. *Issues in Maritime Cyber Security*. Westphalia Press.
- [47] Yevgen Dyravyvyy. 2014. *Preparing for Cyber Battleships-Electronic Chart Display and Information System Security*. An NCC Group Publication. NCC Group, Manchester, UK.
- [48] The Maritime Executive. 2019. *James Fisher and Sons Hit by Cyberattack*. Retrieved May 27, 2024 from <https://www.maritime-executive.com/article/james-fisher-and-sons-hit-by-cyberattack>
- [49] Simon Fossier. 2014. A risk assessment and alerting system for maritime attacks. In *2014 IEEE 26th International Conference on Tools with Artificial Intelligence*. IEEE, 520–526.
- [50] Shanshan Fu, Xiping Yan, Di Zhang, Jing Shi, Chengpeng Wan, and Zhanbing Song. 2014. Use of FMECA Method for Leakage Analysis of LNG Fueled Vessels. In *International Conference on Offshore Mechanics and Arctic Engineering*, Vol. 45424. American Society of Mechanical Engineers, V04AT02A050.
- [51] Keisuke Furumoto, Antti Kolehmainen, Bilhanan Silverajan, Takeshi Takahashi, Daisuke Inoue, and Koji Nakao. 2020. Toward automated smart ships: Designing effective cyber risk management. In *2020 International Conferences on Internet of Things (iThings) and IEEE Green Computing and Communications (GreenCom) and IEEE Cyber, Physical and Social Computing (CPSCom) and IEEE Smart Data (SmartData) and IEEE Congress on Cybermatics (Cybermatics)*. IEEE, 100–105.
- [52] Keke Gai, Haokun Tang, Guangshun Li, Tianxiu Xie, Shuo Wang, Liehuang Zhu, and Kim-Kwang Raymond Choo. 2022. Blockchain-based privacy-preserving positioning data sharing for IoT-enabled maritime transportation systems. *IEEE Transactions on Intelligent Transportation Systems* 24, 2 (2022), 2344–2358.
- [53] Andrea Galieriková. 2019. The human factor and maritime safety. *Transportation research procedia* 40 (2019), 1319–1326.
- [54] Langxiong Gan, Beiyang Ye, Zhiqiu Huang, Yi Xu, Qiaohong Chen, and Yaqing Shu. 2023. Knowledge graph construction based on ship collision accident reports to improve maritime traffic safety. *Ocean & Coastal Management* 240 (2023), 106660.
- [55] Ryan Gauthier and Remzi Seker. 2018. Addressing operator privacy in automatic dependent surveillance-broadcast (ADS-B). (2018).
- [56] Dimitris Gavalas, Theodoros Syriopoulos, and Efthimios Roumpis. 2022. Digital adoption and efficiency in the maritime industry. *Journal of Shipping and Trade* 7, 1 (2022), 11.
- [57] Claudia Glover. 2022. *Port of London Authority hit by 'politically motivated' cyberattack*. Retrieved May 27, 2024 from <https://techmonitor.ai/technology/cybersecurity/port-of-london-authority-cyberattack>
- [58] Inside GNSS. 2018. *Reports of Mass GPS Spoofing Attack in the Black Sea Strengthen Calls for PNT Backup*. Retrieved May 27, 2024 from <https://insidegnss.com/reports-of-mass-gps-spoofing-attack-in-the-black-sea-strengthen-calls-for-pnt-backup/>
- [59] Conner J Goodrum, Colin PF Shields, and David J Singer. 2018. Understanding cascading failures through a vulnerability analysis of interdependent ship-centric distributed systems using networks. *Ocean Engineering* 150 (2018), 36–47.
- [60] Naveen Goud. 2021. *Cyber Attack on Transnet South Africa Shipping*. Retrieved May 27, 2024 from <https://www.cybersecurity-insiders.com/cyber-attack-on-transnet-south-africa-shipping/>
- [61] Athanassios Goudossis and Sokratis K Katsikas. 2019. Towards a secure automatic identification system (AIS). *Journal of Marine Science and Technology* 24 (2019), 410–423.
- [62] Athanassios Goudossis and Sokratis K Katsikas. 2020. Secure ais with identity-based authentication and encryption. *TransNav: International Journal on Marine Navigation and Safety of Sea Transportation* 14, 2 (2020), 287–298.

- [63] Alan Grant, Paul Williams, Nick Ward, and Sally Basker. 2009. GPS jamming and the impact on maritime navigation. *The Journal of Navigation* 62, 2 (2009), 173–187.
- [64] Michelle Grech, Tim Horberry, and Thomas Koester. 2008. *Human factors in the maritime domain*. CRC press.
- [65] Brij Bhooshan Gupta, Akshat Gaurav, Ching-Hsien Hsu, and Bo Jiao. 2021. Identity-based authentication mechanism for secure information sharing in the maritime transport system. *IEEE Transactions on Intelligent Transportation Systems* 24, 2 (2021), 2422–2430.
- [66] Eric Gyamfi, James Adu Ansere, Mohsin Kamal, Muhammad Tariq, and Anca Jurcut. 2022. An adaptive network security system for iot-enabled maritime transportation. *IEEE Transactions on Intelligent Transportation Systems* 24, 2 (2022), 2538–2547.
- [67] Axel Hahn. 2015. Simulation environment for risk assessment of e-navigation systems. In *International Conference on Offshore Mechanics and Arctic Engineering*, Vol. 56499. American Society of Mechanical Engineers, V003T02A072.
- [68] John Hall, Jordan Lee, Joseph Benin, Christopher Armstrong, and Henry Owen. 2015. IEEE 1609 influenced automatic identification system (AIS). In *2015 IEEE 81st Vehicular Technology Conference (VTC Spring)*. IEEE, 1–5.
- [69] Avanthika Vineetha Harish, Kimberly Tam, and Kevin Jones. 2022. Investigating the Security and Accessibility of Voyage Data Recorder Data using a USB attack. *Default journal* (2022).
- [70] Jon Ivar Håvold and Erik Nasset. 2009. From safety culture to safety orientation: Validation and simplification of a safety orientation scale using a sample of seafarers working for Norwegian ship owners. *Safety science* 47, 3 (2009), 305–326.
- [71] Christopher R Hayes. 2016. *Maritime cybersecurity: the future of national security*. Ph.D. Dissertation. Monterey, California: Naval Postgraduate School.
- [72] Xudong He, Jian Wang, Jiqiang Liu, Weiping Ding, Zhen Han, Bin Wang, Jamel Nebhen, and Wei Wang. 2021. DNS rebinding threat modeling and security analysis for local area network of maritime transportation systems. *IEEE Transactions on Intelligent Transportation Systems* 24, 2 (2021), 2643–2655.
- [73] Christian Hemminghaus, Jan Bauer, and Konrad Wolsing. 2021. SIGMAR: Ensuring Integrity and Authenticity of Maritime Systems using Digital Signatures. In *2021 International Symposium on Networks, Computers and Communications (ISNCC)*. IEEE, 1–6.
- [74] Jamie Henry. 2015. *Cyber hack has company deposit \$10M in wrong account*. Retrieved May 27, 2024 from <https://www.insurancebusinessmag.com/ca/news/marine/cyber-hack-has-company-deposit-10m-in-wrong-account-48672.aspx>
- [75] Catherine Hetherington, Rhona Flin, and Kathryn Mearns. 2006. Safety in shipping: The human element. *Journal of safety research* 37, 4 (2006), 401–411.
- [76] Rory Hopcraft, Avanthika Vineetha Harish, Kimberly Tam, and Kevin Jones. 2023. Raising the standard of maritime voyage data recorder security. *Journal of Marine Science and Engineering* 11, 2 (2023), 267.
- [77] Xi Huang, Yuanqiao Wen, Fan Zhang, Haihang Han, Yamin Huang, and Zhongyi Sui. 2023. A review on risk assessment methods for maritime transport. *Ocean Engineering* 279 (2023), 114577.
- [78] Ionut Ilascu. 2018. *Port of Barcelona Suffers Cyberattack*. Retrieved May 27, 2024 from <https://www.bleepingcomputer.com/news/security/port-of-barcelona-suffers-cyberattack/>
- [79] M Ilcev. 2020. New Aspects for Modernization Global Maritime Distress and Safety System (GMDSS). *TransNav: International Journal on Marine Navigation & Safety of Sea Transportation* 14, 4 (2020).
- [80] IMO. 2017. RESOLUTION MSC.428(98) Maritime cyber risk management in safety management systems.
- [81] Tommi Inkinen, Reima Helminen, and Janne Saarikoski. 2019. Port digitalization with open data: Challenges, opportunities, and integrations. *Journal of Open Innovation: Technology, Market, and Complexity* 5, 2 (2019), 30.
- [82] MarketEyes Intelligence. 2024. *Global Port Security Market Emerging Trends And Forecast*. Retrieved June 27, 2024 from <https://www.linkedin.com/pulse/global-port-security-market-emerging-trends-forecast-olngf/>
- [83] Port Technology International. 2021. *Digital maritime market worth \$159 billion*. Retrieved June 27, 2024 from <https://www.porttechnology.org/news/digital-maritime-market-worth-159-billion/>
- [84] Clément Iphar, Aldo Napoli, and Cyril Ray. 2015. Detection of false AIS messages for the improvement of maritime situational awareness. In *Oceans 2015-mts/ieee washington*. IEEE, 1–7.
- [85] Muhammad Asim Ismail, Shahid Ali, Sartaj Khan, Zeeshan Babar, and Muhammad Mazhar. 2021. A survey of Indian Ocean region maritime security: Technological advancements and innovative solutions. In *2021 International Conference on Frontiers of Information Technology (FIT)*. IEEE, 66–71.
- [86] Jolanta Jozczuk-Januszewska. 2012. The benefits of cloud computing in the maritime transport. In *Telematics in the Transport Environment: 12th International Conference on Transport Systems Telematics, TST 2012, Katowice-Ustroń, Poland, October 10–13, 2012. Selected Papers 12*. Springer, 258–266.
- [87] Eleni-Maria Kalogeraki, Spyridon Papastergiou, Haralambos Mouratidis, and Nineta Polemi. 2018. A novel risk assessment methodology for SCADA maritime logistics environments. *Applied Sciences* 8, 9 (2018), 1477.

- [88] Chronis Kapalidis, Stavros Karamperidis, Tim Watson, and Georgios Koligiannis. 2022. A Vulnerability Centric System of Systems Analysis on the Maritime Transportation Sector Most Valuable Assets: Recommendations for Port Facilities and Ships. *Journal of Marine Science and Engineering* 10, 10 (2022), 1486.
- [89] Vladimir Karetnikov, Evgeniy Ol'Khovik, Aleksandra Ivanova, and Artem Butsanets. 2019. Technology level and development trends of autonomous shipping means. In *Energy Management of Municipal Transportation Facilities and Transport*. Springer, 421–432.
- [90] Peter Kelly. 2022. A novel technique to identify AIS transmissions from vessels which attempt to obscure their position by switching their AIS transponder from normal transmit power mode to low transmit power mode. *Expert Systems with Applications* 202 (2022), 117205.
- [91] Gary C Kessler, J Philip Craiger, and Jon C Haass. 2018. A taxonomy framework for maritime cybersecurity: A demonstration using the automatic identification system. *TransNav: International Journal on Marine Navigation and Safety of Sea Transportation* 12, 3 (2018), 429–437.
- [92] Gary C Kessler and Steven D Shepard. 2020. *Maritime cybersecurity: a guide for leaders and managers*. Amazon Digital Services LLC - KDP Print US.
- [93] Yongjae Kim, Yujae Song, and Sung Hoon Lim. 2019. Hierarchical maritime radio networks for internet of maritime things. *IEEE Access* 7 (2019), 54218–54227.
- [94] Ioannis Kontopoulos, Giannis Spiliopoulos, Dimitrios Zissis, Konstantinos Chatzikokolakis, and Alexander Artikis. 2018. Countering real-time stream poisoning: An architecture for detecting vessel spoofing in streams of AIS data. In *2018 IEEE 16th Intl Conf on Dependable, Autonomic and Secure Computing, 16th Intl Conf on Pervasive Intelligence and Computing, 4th Intl Conf on Big Data Intelligence and Computing and Cyber Science and Technology Congress (DASC/PiCom/DataCom/CyberSciTech)*. IEEE, 981–986.
- [95] K Korcz. 2023. Key points of the modernized GMDSS system. *TransNav: International Journal on Marine Navigation and Safety of Sea Transportation* 17 (2023).
- [96] Kira Kowalska and Leto Peel. 2012. Maritime anomaly detection using Gaussian process active learning. In *2012 15th International Conference on Information Fusion*. IEEE, 1164–1171.
- [97] Prabhat Kumar, Govind P Gupta, Rakesh Tripathi, Sahil Garg, and Mohammad Mehedi Hassan. 2021. DLTIF: Deep learning-driven cyber threat intelligence modeling and identification framework in IoT-enabled maritime transportation systems. *IEEE Transactions on Intelligent Transportation Systems* 24, 2 (2021), 2472–2481.
- [98] Bernard Kusi. 2015. Port security-threats and vulnerabilities. (2015).
- [99] Sotiria Lagouvardou. 2018. Maritime Cyber Security: concepts, problems and models. *Kongens Lyngby, Copenhagen* (2018).
- [100] Pedro Merino Laso, Loic Salmon, Maya Bozhilova, Ivan Ivanov, Nikolai Stoianov, Grigor Velev, Christophe Claramunt, and Yantsislav Yanakiev. 2022. ISOLA: an innovative approach to cyber threat detection in cruise shipping. In *Developments and Advances in Defense and Security: Proceedings of MICRADS 2021*. Springer, 71–81.
- [101] Donghyeok Lee and Namje Park. 2017. Geocasting-based synchronization of Almanac on the maritime cloud for distributed smart surveillance. *The Journal of Supercomputing* 73 (2017), 1103–1118.
- [102] Walmor Cristino Leite Junior, Claudio Coreixas de Moraes, Carlos EP de Albuquerque, Raphael Carlos Santos Machado, and Alan Oliveira de Sá. 2021. A triggering mechanism for cyber-attacks in naval sensors and systems. *Sensors* 21, 9 (2021), 3195.
- [103] Kungpeng Li, Amir Gharehgozli, Mohit Vijay Ahuja, and Jun-Yeon Lee. 2020. Blockchain in maritime supply chain: A synthesis analysis of benefits, challenges and limitations. *Journal of Supply Chain and Operations Management* 18, 2 (2020), 257.
- [104] Annabelle Liang. 2023. *DP World: Australia sites back online after cyber-attack*. Retrieved May 27, 2024 from <https://www.bbc.com/news/business-67400164>
- [105] Mikael Lind, Wolfgang Lehmacher, J Hoffmann, L Jensen, T Notteboom, T Rydbergh, P Sand, S Haraldson, R White, H Becha, et al. 2021. Improving a congested maritime supply chain with time slot management for port calls.
- [106] Dengzhi Liu, Yong Zhang, Weizheng Wang, Kapal Dev, and Sunder Ali Khowaja. 2021. Flexible data integrity checking with original data recovery in IoT-enabled maritime transportation systems. *IEEE Transactions on Intelligent Transportation Systems* 24, 2 (2021), 2618–2629.
- [107] Honglu Liu, Zhihong Tian, Anqiang Huang, and Zaili Yang. 2018. Analysis of vulnerabilities in maritime supply chains. *Reliability Engineering & System Safety* 169 (2018), 475–484.
- [108] Jiaguo Liu, Juanjuan Wu, and Yu Gong. 2023. Maritime supply chain resilience: From concept to practice. *Computers & Industrial Engineering* 182 (2023), 109366.
- [109] Giacomo Longo, Alessio Merlo, Alessandro Armando, and Enrico Russo. 2023. Electronic attacks as a cyber false flag against maritime radars systems. In *2023 IEEE 48th Conference on Local Computer Networks (LCN)*. IEEE, 1–6.
- [110] Giacomo Longo, Alessandro Orlich, Stefano Musante, Alessio Merlo, and Enrico Russo. 2023. MaCySTe: A virtual testbed for maritime cybersecurity. *SoftwareX* 23 (2023), 101426.

- [111] Giacomo Longo, Enrico Russo, Alessandro Armando, and Alessio Merlo. 2023. Attacking (and defending) the maritime radar system. *IEEE Transactions on Information Forensics and Security* (2023).
- [112] Sean Lyngaas. 2023. *Japan's largest port hit with ransomware attack*. Retrieved May 27, 2024 from <https://edition.cnn.com/2023/07/06/tech/japan-port-ransomware-attack/index.html>
- [113] F Xavier Martínez de Osés and África Uya Juncadella. 2021. Global maritime surveillance and oceanic vessel traffic services: towards the e-navigation. *WMU Journal of Maritime Affairs* 20 (2021), 3–16.
- [114] Lee Mathews. 2017. *NotPetya Ransomware Attack Cost Shipping Giant Maersk Over \$200 Million*. Retrieved May 27, 2024 from <https://www.forbes.com/sites/leemathews/2017/08/16/notpetya-ransomware-attack-cost-shipping-giant-maersk-over-200-million/?sh=1b5f5dd34f9a>
- [115] Daniel Medina, Christoph Lass, Emilio Pérez Marcos, Ralf Ziebold, Pau Closas, and Jesús García. 2019. On GNSS jamming threat from the maritime navigation perspective. In *2019 22th International Conference on Information Fusion (FUSION)*. IEEE, 1–7.
- [116] Per Håkon Meland, Karin Bernsmed, Egil Wille, Ørnulf Jan Rødseth, and Dag Atle Nesheim. 2021. A retrospective analysis of maritime cyber security incidents. (2021).
- [117] Duc H Nguyen. 2020. *Hardening automatic identification systems: Providing integrity through an application of lightweight cryptographic techniques*. Ph. D. Dissertation. Monterey, CA; Naval Postgraduate School.
- [118] Joseph L Nimmich and Dana A Goward. 2007. Maritime domain awareness: the key to maritime security. *International Law Studies* 83, 1 (2007), 6.
- [119] Rob O'Dwyer. 2023. *Maritime Cyber Attack Database launched*. Retrieved May 27, 2024 from <https://smartmaritimemetwork.com/2023/07/16/maritime-cyber-attack-database-launched/>
- [120] Singapore Polytechnic Centre of Excellence in Maritime safety. 2021. *Advanced Navigation Research Simulator (ANRS)*. Retrieved June 27, 2024 from https://www.mpa.gov.sg/docs/mpalibraries/media-releases/older/annex-1-anrs-fact-sheet.pdf?sfvrsn=fd4df26c_0
- [121] Gabriele Oligeri, Savio Sciancalepore, and Roberto Di Pietro. 2020. GNSS spoofing detection via opportunistic IRIDIUM signals. In *Proceedings of the 13th ACM Conference on Security and Privacy in Wireless and Mobile Networks*. 42–52.
- [122] Aybars Oruc. 2020. Claims of state-sponsored cyberattack in the maritime industry. In *Conference Proceedings of INEC*.
- [123] Mathew J Owens, Mike Lockwood, Luke A Barnard, Chris J Scott, Carl Haines, and Allan Macneil. 2021. Extreme space-weather events and the solar cycle. *Solar Physics* 296, 5 (2021), 82.
- [124] Pierluigi Paganini. 2021. *PORT OF HOUSTON WAS HIT BY AN ALLEGED STATE-SPONSORED ATTACK*. Retrieved May 27, 2024 from <https://securityaffairs.com/122599/hacking/port-of-houston-cyberattack.html>
- [125] Panayiotis Papageorgiou, Zacharias Dermatis, Athanasios Anastasiou, Panagiotis Liargovas, and Stratos Papadimitriou. 2024. Using a proposed risk computation procedure and bow-tie diagram as a method for maritime security assessment. *Transportation research record* 2678, 2 (2024), 318–339.
- [126] Changki Park, Wenming Shi, Wei Zhang, Christos Kontovas, and Chia Hsun Chang. 2019. Cybersecurity in the maritime industry: A literature review. In *20th Commemorative Annual General Assembly, AGA 2019-Proceedings of the International Association of Maritime Universities Conference, IAMUC 2019*. 79–86.
- [127] Jin Hyoung Park. 2017. The maritime cloud - a maritime connectivity platform for digitalized maritime sectors. *The Journal of Ocean Technology* 12 (2017), 144–145.
- [128] James Pavur, Daniel Moser, Martin Strohmeier, Vincent Lenders, and Ivan Martinovic. 2020. A tale of sea and sky on the security of maritime VSAT communications. In *2020 IEEE Symposium on Security and Privacy (SP)*. IEEE, 1384–1400.
- [129] Mario Piccinelli and Paolo Gubian. 2013. Modern ships Voyage Data Recorders: A forensics perspective on the Costa Concordia shipwreck. *Digital investigation* 10 (2013), S41–S49.
- [130] Nikolaos Polatidis, Michalis Pavlidis, and Haralambos Mouratidis. 2018. Cyber-attack path discovery in a dynamic supply chain maritime risk management system. *Computer Standards & Interfaces* 56 (2018), 74–82.
- [131] Iosif Progoulakis, Nikitas Nikitakos, Dimitrios Dalaklis, Anastasia Christodoulou, Angelos Dalaklis, and Razali Yaacob. 2023. Digitalization and cyber physical security aspects in maritime transportation and port infrastructure. In *Smart Ports and Robotic Systems: Navigating the Waves of Techno-Regulation and Governance*. Springer, 227–248.
- [132] Iosif Progoulakis, Paul Rohmeyer, and Nikitas Nikitakos. 2021. Cyber physical systems security for maritime assets. *Journal of Marine Science and Engineering* 9, 12 (2021), 1384.
- [133] Leon Purton, Hussein Abbass, and Sameer Alam. 2010. Identification of ADS-B system vulnerabilities and threats. In *Australian Transport Research Forum, Canberra*. sn, 1–16.
- [134] Payam Rahimi, Nasir D Khan, Chrysostomos Chrysostomou, Vasos Vassiliou, and Babar Nazir. 2020. A secure communication for maritime iot applications using blockchain technology. In *2020 16th International Conference on Distributed Computing in Sensor Systems (DCOSS)*. IEEE, 244–251.

- [135] Priyanga Rajaram, Mark Goh, and Jianying Zhou. 2022. Guidelines for cyber risk management in shipboard operational technology systems. In *Journal of Physics: Conference Series*, Vol. 2311. IOP Publishing, 012002.
- [136] Anna Ribeiro. 2023. *Port of Lisbon targeted by LockBit ransomware hackers, website still down*. Retrieved May 27, 2024 from <https://industrialcyber.co/news/port-of-lisbon-targeted-by-lockbit-ransomware-hackers-website-still-down/>
- [137] Pančo Ristov, Mile Perić, and Vinko Tomas. 2014. The implemetation of cloud computing in shipping companies. *Pomorstvo* 28, 1 (2014), 80–87.
- [138] BS Rivkin. 2023. Maritime Cybersecurity. Navigational Aspect. *Gyroscopy and Navigation* 14, 4 (2023), 386–400.
- [139] Ruben Santamarta. 2014. SATCOM terminals: Hacking by air, sea, and land. *DEFCON White Paper* (2014).
- [140] Ruben Santamarta. 2018. *Last call for SATCOM security*. IOActive Seattle, WA.
- [141] Desmond Schmidt, Kenneth Radke, Seyit Camtepe, Ernest Foo, and Michał Ren. 2016. A Survey and Analysis of the GNSS Spoofing Threat and Countermeasures. *ACM Comput. Surv.* 48, 4, Article 64 (may 2016), 31 pages. <https://doi.org/10.1145/2897166>
- [142] Monina Schwarz, Matthias Marx, and Hannes Federrath. 2021. A structured analysis of information security incidents in the maritime sector. *arXiv preprint arXiv:2112.06545* (2021).
- [143] Savio Sciancalepore, Pietro Tedeschi, Ahmed Aziz, and Roberto Di Pietro. 2021. Auth-AIS: secure, flexible, and backward-compatible authentication of vessels AIS broadcasts. *IEEE Transactions on Dependable and Secure Computing* 19, 4 (2021), 2709–2726.
- [144] Chalermpong Senarak. 2023. Port cyberattacks from 2011 to 2023: a literature review and discussion of selected cases. *Maritime Economics & Logistics* (2023), 1–26.
- [145] Anna Sergi and Alexandria Reid. 2021. *Ports, crime and security: Governing and policing seaports in a Changing World*. Policy Press.
- [146] Xin Shi, Hui Zhuang, and Dong Xu. 2021. Structured survey of human factor-related maritime accident research. *Ocean Engineering* 237 (2021), 109561.
- [147] Ömer Söner, Gizem Kayisoglu, Pelin Bolat, and Kimberly Tam. 2023. Cybersecurity risk assessment of VDR. *The Journal of Navigation* 76, 1 (2023), 20–37.
- [148] Julian Spravil, Christian Hemminghaus, Merlin von Rechenberg, Elmar Padilla, and Jan Bauer. 2023. Detecting maritime gps spoofing attacks based on nmea sentence integrity monitoring. *Journal of Marine Science and Engineering* 11, 5 (2023), 928.
- [149] Igné Stalmokaitė and Björn Hassler. 2020. Dynamic capabilities and strategic reorientation towards decarbonisation in Baltic Sea shipping. *Environmental Innovation and Societal Transitions* 37 (2020), 187–202.
- [150] Igné Stalmokaitė, Tommy Larsson Segerlind, and Johanna Yliskylä-Peuralahti. 2023. Revival of wind-powered shipping: Comparing the early-stage innovation process of an incumbent and a newcomer firm. *Business Strategy and the Environment* 32, 2 (2023), 958–975.
- [151] Martin Strohmeier, Vincent Lenders, and Ivan Martinovic. 2014. On the security of the automatic dependent surveillance-broadcast protocol. *IEEE Communications Surveys & Tutorials* 17, 2 (2014), 1066–1087.
- [152] Pengchuan Su, Nan Sun, Liehuang Zhu, Yandong Li, Rongrong Bi, Meng Li, and Zijian Zhang. 2017. A privacy-preserving and vessel authentication scheme using automatic identification system. In *Proceedings of the Fifth ACM International Workshop on Security in Cloud Computing*. 83–90.
- [153] Sharmin Sultana, Peter Okoh, Stein Haugen, and Jan Erik Vinnem. 2019. Hazard analysis: Application of STPA to ship-to-ship transfer of LNG. *Journal of Loss Prevention in the Process Industries* 60 (2019), 241–252.
- [154] Boris Svilicic, David Brčić, Srdjan Žuškin, and David Kalebić. 2019. Raising awareness on cyber security of ECDIS. *TransNav: International Journal on Marine Navigation and Safety of Sea Transportation* 13, 1 (2019), 231–236.
- [155] Boris Svilicic, Junzo Kamahara, Jasmin Celic, and Johan Bolmsten. 2019. Assessing ship cyber risks: A framework and case study of ECDIS security. *WMU Journal of Maritime Affairs* 18 (2019), 509–520.
- [156] Boris Svilicic, Junzo Kamahara, Matthew Rooks, and Yoshiji Yano. 2019. Maritime cyber risk management: An experimental ship assessment. *The Journal of Navigation* 72, 5 (2019), 1108–1120.
- [157] Boris Svilicic, Miho Kristić, Srdan Žuškin, and David Brčić. 2020. Paperless ship navigation: cyber security weaknesses. *Journal of Transportation Security* 13 (2020), 203–214.
- [158] Boris Svilicic, Igor Rudan, Vlado Frančić, and Mateo Doričić. 2019. Shipboard ECDIS cyber security: Third-party component threats. *Pomorstvo* 33, 2 (2019), 176–180.
- [159] Kimberly Tam, Kevin Forshaw, and Kevin Jones. 2019. Cyber-SHIP: Developing next generation maritime cyber research capabilities. In *International Conference on Marine Engineering and Technology Oman*.
- [160] Kimberly Tam and Kevin D Jones. 2018. Maritime cybersecurity policy: the scope and impact of evolving technology on international shipping. *Journal of Cyber Policy* 3, 2 (2018), 147–164.
- [161] UNCTAD. 2022. *Review of Maritime Transport 2022*. Retrieved June 27, 2024 from https://unctad.org/system/files/official-document/rmt2022_en.pdf

- [162] Koen van de Merwe, Steven Mallam, Øystein Engelhardtson, and Salman Nazir. 2023. Towards an approach to define transparency requirements for maritime collision avoidance. In *Proceedings of the Human Factors and Ergonomics Society Annual Meeting*, Vol. 67. SAGE Publications Sage CA: Los Angeles, CA, 483–488.
- [163] Chen Wang, Jian Shen, Pandi Vijayakumar, and Brij B Gupta. 2021. Attribute-based secure data aggregation for isolated IoT-enabled maritime transportation systems. *IEEE Transactions on Intelligent Transportation Systems* 24, 2 (2021), 2608–2617.
- [164] Huanxin Wang, Zhengjiang Liu, Zhichen Liu, Xinjian Wang, and Jin Wang. 2022. GIS-based analysis on the spatial patterns of global maritime accidents. *Ocean engineering* 245 (2022), 110569.
- [165] Michael Mao Wang, Jingjing Zhang, and Xiaohu You. 2020. Machine-type communication for maritime Internet of Things: A design. *IEEE Communications Surveys & Tutorials* 22, 4 (2020), 2550–2585.
- [166] Vera Wendler-Bosco and Charles Nicholson. 2020. Port disruption impact on the maritime supply chain: a literature review. *Sustainable and Resilient Infrastructure* 5, 6 (2020), 378–394.
- [167] Alec Wilson, Ryan Menzies, Neela Morarji, David Foster, Marco Casassa Mont, Esin Turkbeyler, and Lisa Gralowski. 2024. Multi-Agent Reinforcement Learning for Maritime Operational Technology Cyber Security. *arXiv preprint arXiv:2401.10149* (2024).
- [168] Konrad Wolsing, Antoine Saillard, Jan Bauer, Eric Wagner, Christian van Sloun, Ina Berenice Fink, Mari Schmidt, Klaus Wehrle, and Martin Henze. 2022. Network attacks against marine radar systems: A taxonomy, simulation environment, and dataset. In *2022 IEEE 47th Conference on Local Computer Networks (LCN)*. IEEE, 114–122.
- [169] Ian Wood and Stella Kim. 2016. *North Korea Jams GPS Signals to Fishing Boats: South*. Retrieved May 27, 2024 from <https://www.nbcnews.com/news/world/north-korea-jams-gps-signals-fishing-boats-south-n548986>
- [170] Zhijun Wu, Qingbo Pan, Meng Yue, and Shaopu Ma. 2018. An Approach of Security Protection for VSAT Network. In *2018 17th IEEE International Conference On Trust, Security And Privacy In Computing And Communications/12th IEEE International Conference On Big Data Science And Engineering (TrustCom/BigDataSE)*. IEEE, 1511–1516.
- [171] Muhammad Mudassar Yamin, Basel Katt, and Vasileios Gkioulos. 2020. Cyber ranges and security testbeds: Scenarios, functions, tools and architecture. *Computers & Security* 88 (2020), 101636.
- [172] Chaoqun Yang, Li Feng, Heng Zhang, Shibo He, and Zhiguo Shi. 2018. A novel data fusion algorithm to combat false data injection attacks in networked radar systems. *IEEE Transactions on Signal and Information Processing over Networks* 4, 1 (2018), 125–136.
- [173] Yi-Chih Yang. 2011. Risk management of Taiwan’s maritime supply chain security. *Safety science* 49, 3 (2011), 382–393.
- [174] Hongchu Yu, Qiang Meng, Zhixiang Fang, and Jingxian Liu. 2023. Literature review on maritime cybersecurity: state-of-the-art. *The Journal of Navigation* (2023), 1–14.
- [175] Katie Zeng. 2021. *BACKGROUND: GNSS spoofing in China and beyond*. Retrieved May 27, 2024 from <https://www.riskintelligence.eu/background-and-guides/background-gnss-spoofing-in-china-and-beyond>
- [176] Yulong Zhan, Feng Xu, and Yue Zhang. 2009. The application of HAZOP analysis on risk assessment of the 10000TEU container ships. In *2009 International Asia Symposium on Intelligent Interaction and Affective Computing*. IEEE, 59–62.
- [177] Lei Zhang, Yuxuan Zhu, Osiris A Valdez Banda, Lei Du, Langxiong Gan, and Xiaobin Li. 2024. Navigational risk assessment of inland waters based on bi-directional PSO-LSTM algorithm and ship maneuvering characteristics. *Ocean Engineering* 310 (2024), 118628.
- [178] Peiying Zhang, Yaqi Wang, Gagangeet Singh Aujla, Anish Jindal, and Yasser D Al-Otaibi. 2022. A blockchain-based authentication scheme and secure architecture for IoT-enabled maritime transportation systems. *IEEE Transactions on Intelligent Transportation Systems* 24, 2 (2022), 2322–2331.
- [179] Jianying Zhou. 2024. The Need of Testbeds for Cyberphysical System Security. *IEEE Security & Privacy* 22, 4 (2024), 4–6.

A APPENDIX

In this section, we have included supplementary information for our survey. Firstly, we present definitions for a list of discussed vessel components. We further analyzed their vulnerabilities, highlighting the possible attacks that can happen. Lastly, we have provided a list of all the acronyms used in this survey.

A.1 Definitions of Vessel Components

Vessel components refer to the various systems, equipment, and structural elements that collectively form a ship or marine vessel. Modern vessels incorporate a range of digital systems and networks that control and monitor these physical components, including integrated bridge systems, engine

control and monitoring systems, and onboard networks. In this survey, we mainly focus on the components found in IBS because those components are mostly discussed.

AIS: The AIS is a Very High Frequency (VHF) radio broadcasting system that is used for traffic monitoring (Vessel Traffic Services), collision avoidance, search and rescue operations, aids to navigation, weather forecast (Australian Maritime Safety Authority) and accident investigation [23][138].

GNSS: GNSS is an umbrella term for satellite-based navigation systems that provide global coverage for position, velocity, and timing information. There are currently four primary GNSS in operation: GPS operated by the United States, GLONASS operated by Russia, Galileo operated by the European Union, and BeiDou operated by China. In the maritime context, GNSS plays a crucial role in various aspects of operations, including navigation, vessel monitoring, autonomous shipping, timing, and integration with other onboard systems.

VDR: VDR is an essential system that acts as a "black box" to record key parametric data about a ship's voyage, which can then be recovered and analyzed to investigate the causes of a maritime accident. VDR continuously stores data related to the status, command, and control of the ship from various sensors and systems, including date/time, ship's position, speed, heading, bridge audio, radio communications, radar data, hull openings status, watertight doors status, etc [129].

RADAR: RADAR is an object detection system that emits radio waves and analyzes the reflected signals to detect the presence, direction, and range of objects in the surrounding environment [11]. It is indispensable for maintaining situational awareness and ensuring the safety of maritime operations, particularly in low visibility conditions or when navigating through congested waters.

ECDIS: ECDIS is a computer-based navigation system that serves as a digital alternative to traditional paper nautical charts, providing navigators with real-time, interactive, and comprehensive information about the ship's position, course, and surrounding environment. It combines information from multiple navigational aids and sensors, including GNSS, Radar, and AIS [138]. This information is superimposed on digital charts and empowers navigation officers to make informed decisions and maintain situational awareness.

VSAT: Maritime VSAT systems provide essential connectivity and communication services, including internet access for crew and passengers, operational communications between ship and shore, real-time navigation updates, weather forecasts, and safety information.

GMDSS: The GMDSS was developed by the International Maritime Organization (IMO) and became fully operational in 1999. It is designed to perform the main functions such as transmitting ship-to-shore distress alerts, coordinating search and rescue operations and providing general radiocommunications [79]. The implementation of GMDSS has significantly improved maritime safety and rescue operations globally, providing a standardized system for distress communication and alerting across international waters.

A.2 Vulnerabilities of Vessel Components

The vulnerabilities of vessel components encompass a wide range of potential susceptibilities that could be exploited to compromise the safety, security, or operational integrity of a ship. These vulnerabilities can arise from various sources, including inherent design flaws, manufacturing defects, inadequate maintenance, human error, or intentional tampering.

Vulnerability of AIS: It was developed in the 1990s with a primary focus on enhancing maritime safety and navigation, but its design did not thoroughly consider the potential risks posed by active cyber attacks or malicious actors seeking to exploit vulnerabilities in the system. Numerous known security flaws exist [61][92]:

- The absence of built-in mechanisms in AIS to authenticate the geographical origin of transmitted messages allows a device to broadcast AIS data that is not accurate in indicating its location. Because of this flaw, a hacker might pretend to be an AIS transmitter and fool other ships or shore stations about the actual location of the transmitter.
- The absence of timestamp information in AIS communications exposes the system to replay assaults. Attackers have the capacity to record and replay valid AIS broadcasts, which compromises the system's dependability for forensic investigation and situational awareness by giving misleading perceptions about a vessel's previous position.
- AIS lacks message authentication, the system is unable to confirm the sender's actual identity. Anyone with the ability to send AIS packets can impersonate any other AIS device, which puts vessels that depend on the accuracy of AIS messages at danger for confusion, deceit, and accidents.
- Since AIS does not have mechanisms to guarantee the integrity of sent data, it is impossible to confirm that the data sent by an AIS device is accurate and has not been tampered with. This weakness makes it possible for a vessel to falsely portray its attributes, including size or type.
- AIS-broadcast communications lack encryption. Openly available AIS data may be found on a number of websites, including Marine Traffic, and can offer a wealth of information about ships and their travels, including specifics about the ship's identity, cargo, and current position [23][68].

Vulnerability of GNSS: The main GNSS vulnerabilities that have been thoroughly examined are the radio frequency hazards associated with jamming and spoofing. Extreme space weather events have been identified as a significant vulnerability for GNSS, in addition to radio frequency concerns. In contrast to physical assaults, which are mostly theoretical because mature nation-states demand highly developed capabilities, extreme space weather phenomena represent a genuine and continuous threat to GNSS satellites and their communications. These occurrences are real threats, even though their frequency and intensity vary over the course of the 11-year solar cycle [123]. There are several reasons why GNSS are susceptible [46][141]:

- By the time GNSS signals reach the Earth's surface, they are inherently weak because they are coming from satellites in a medium Earth orbit. These signals are weaker when they reach GNSS receivers due to the great distances they must travel and the power constraints of satellite transmitters. Due to this intrinsic weakness, hostile actors can use readily available jamming equipment to disrupt or block GNSS signals.
- Many GNSS signals are open and unencrypted, which makes them vulnerable to spoofing attacks, in which malevolent actors create and disseminate phony signals that appear to be real. Meaconing is a kind of GNSS spoofing attack in which the attacker first adds a predetermined delay to the GNSS signals they have intercepted, then rebroadcasts them.
- GNSS has a significant reliance on satellites, which are vulnerable to potential physical attacks (such as those using anti-satellite weapons) as well as space weather phenomena (such solar flares).

Vulnerability of VDR: VDR data could be contested in court and declared inadmissible as evidence if it turns out to be easily altered or manipulated. Legal proceedings pertaining to maritime accidents, insurance claims, and liability issues may be significantly impacted by this [9]. Consequently, VDR may be exposed to hazards associated with data availability, data integrity problems, and confidentiality breaches.

Vulnerability of RADAR: A number of subsystems, including antennas, transmitters, receivers, processors, and displays, make up the intricate marine RADAR systems [38]. There could be

vulnerabilities in every component, which would increase the number of attack surfaces. However, given the specialized nature of marine radar systems and the challenges associated with conducting thorough security assessments in real-world scenarios, there might be fewer opportunities to thoroughly inspect the system for vulnerabilities. The task of simulating actual circumstances for security testing is hampered by the complicated operational settings, which include the sea environment, weather, and the requirement for uninterrupted functionality.

Vulnerability of ECDIS: The vulnerabilities in ECDIS are largely caused by a combination of technological factors and organisational issues as the maritime industry has been slow to adapt to the rapidly evolving cyber threat landscape. The main vulnerabilities identified in ECDIS are [154][155]:

- ECDIS often operates on outdated operating systems like Windows XP or Windows 7, which no longer receive security updates. Additionally, third-party applications such as web servers and remote desktop tools are frequently outdated and contain known vulnerabilities.
- Security patches for ECDIS systems are not consistently applied as it is a manual and time-consuming process.
- Insecure network configuration and services, such as directory traversal, unsafe HTTP methods allowed, and header injection vulnerabilities in the Apache web server [47].
- Identical hardware/software used for primary and backup ECDIS: If one ECDIS workstation is compromised, the other is equally vulnerable to the same threat

Vulnerability of VSAT: Many maritime operators appear to be unaware of the risks associated with transmitting sensitive data over satellite links without adequate security measures [170], and numerous maritime VSAT networks continue to use outdated and insecure protocols [128]. The author [140] observes a trend where historically isolated devices, such as VSAT systems, are now being designed with additional communication technologies like WiFi and Bluetooth. Although not explicitly identified as a cause of vulnerabilities, this trend implies that increased connectivity may expand the attack surface if proper security measures are not implemented.

Vulnerability of GMDSS: The radio and satellite communications used by GMDSS can be intentionally jammed or unintentionally interfered with, which could disrupt its functionalities [160] GMDSS relies on various interconnected systems. A vulnerability in one system could potentially affect the entire GMDSS functionality. Systems like GPS, which GMDSS relies on for positioning, can be spoofed to provide false location data [79].

A.3 Acronyms

Table 3. Acronyms

Acronym	Description
ABS	American Bureau of Shipping
ADS-B	Automatic Dependent Surveillance-Broadcast
AI-PAML	Adaptive Incremental Passive-Aggressive Machine Learning
AIS	Automatic Identification System
ANRS	Advanced Navigation Research Simulator
BIMCO	Baltic and International Maritime Council
DAU	Data Acquisition Unit
DDoS	Distributed Denial of Service
DoS	Denial of Service
DRFM	Digital Radio Frequency Memory
DSIAS	Digital Signature Based Identity Authentication Scheme
EA	Electronic Attack
ECDIS	Electronic Chart Display and Information System
ECDSA	Elliptic Curve Digital Signature Algorithm
eMIR	eMaritime Integrated Reference Platform
ENC	Electronic Navigational Chart
FMEA	Failure Mode and Effect Analysis
FMECA	Failure Mode, Effect, and Criticality Analysis
GHG	Greenhouse Gas
GP	Gaussian Process
GIS	Geographic Information System
GMDSS	Global Maritime Distress and Safety System
GNSS	Global Navigation Satellite System
GPS	Global Positioning System
HAZOP	Hazard and Operability Analysis
HFACS	Human Factors Analysis and Classification System
HW-F	High Weight Function
IBS	Integrated Bridge System
IMO	International Maritime Organisation
IoT	Internet of Things
ISPS	International Ship and Port Facility Security
IT	Information Technology
lite-CA	Lite Certification Authority
LSTM	Long Short-Term Memory
MARL	Multi-Agent Reinforcement Learning
MCAD	Maritime Cyber Attack Database

Acronym	Description
mIBC	Maritime Certificate-less Identity-Based Public Key Cryptography
MTPPS	Mix-zone Based Trajectory Privacy Protection Scheme
NAVTEX	Navigation Telex
NIST	National Institute of Standards and Technology
NMEA	National Marine Electronics Association
OT	Operational Technology
PDCA	Plan-Do-Check-Act
PKI	Public Key Infrastructure
PLA	Port of London Authority
PLCs	Programmable Logic Controllers
PoC	Proof-of-Concept
PPI	Plan Position Indicator
RSSI	Received Signal Strength Indicator
S2ML	Dual Stack Machine Learning
SATCOM	Satellite Communications
SEI	Specific Emitter Identification
RADAR	RADio Detection And Ranging
UAV	Unmanned Aerial Vehicle
VDES	VHF Data Exchange System
VDR	Voyage Data Recorder
VHF	Very High Frequency
VSAT	Very Small Aperture Terminal