

# Exact equality of the MSEs for two types of nonlinear adaptive systems: Saturation and dead-zone types

Seiji Miyoshi\* and Yua Yamaguchi†

September 10, 2024

## Abstract

Adaptive signal processing systems, commonly utilized in applications such as active noise control and acoustic echo cancellation, often encompass nonlinearities due to hardware components such as loudspeakers, microphones, and amplifiers. Examining the impact of these nonlinearities on the overall performance of adaptive systems is critically important. In this study, we employ a statistical-mechanical method to investigate the behaviors of adaptive systems, each containing an unknown system with a nonlinearity in its output. We specifically address two types of nonlinearity: saturation and dead-zone types. We analyze both the dynamic and steady-state behaviors of these systems under the effect of such nonlinearities. Our findings indicate that when the saturation value is equal to the dead-zone width, the mean square errors (MSEs) in steady states are identical for both nonlinearity types. Furthermore, we derive a self-consistent equation to obtain the saturation value and dead-zone width that maximize the steady-state MSE. We theoretically clarify that these values depend on neither the step size nor the variance of background noise.

Keywords: adaptive filter, adaptive signal processing, system identification, LMS algorithm, saturation-type nonlinearity, dead-zone-type nonlinearity, statistical-mechanical analysis

## 1 Introduction

Adaptive signal processing is utilized extensively in fields such as communication and acoustic systems [1, 2]. It plays a key role in various applications including active noise control (ANC) [3–6], active vibration control (AVC) [7], acoustic echo cancellation [8], and system identification [9]. These systems often include power amplifiers and transducers, such as loudspeakers and microphones, both of which exhibit significant nonlinearities [1, 2]. Thoroughly examining the impact of these elements on the overall performance of adaptive systems is critically important. Therefore, numerous studies have been conducted on adaptive signal processing systems that integrate these nonlinear elements [10–31, 33]. Bershad [21] analyzed the effects of saturation-type nonlinearity in the least-mean-square (LMS) algorithm, specifically considering a small step size and a nonlinearity described by the formula  $(1 - e^{-ax})$ . Costa *et al.* [22] studied adaptive filters with error function (erf) saturation-type nonlinearity, assuming a small step size. Costa *et al.* [23, 24] analyzed ANC in which the secondary path has an erf saturation-type nonlinearity. Furthermore, Snyder and Tanaka [25] suggested replacing the finite-duration impulse response (FIR) filter with a neural network to deal with the primary path nonlinearity in ANC and AVC systems. Costa [26] conducted an analysis of a hearing aid feedback canceller that featured erf saturation-type nonlinearity. Costa *et al.* [27] investigated a model in which the output of the adaptive filter demonstrates dead-zone-type nonlinearity under the

\*Department of Electrical, Electronic and Information Engineering, Faculty of Engineering Science, Kansai University, 3-3-35 Yamate-cho, Suita-shi, Osaka 564-8680, Japan (e-mail: miyoshi@kansai-u.ac.jp), This work was partially supported by JSPS KAKENHI Grant Number JP20K04494.

†Nidec Advance Technology Corporation, Nidec PARK Bldg. C, 1-1 Higashinokuchi, Morimoto-cho, Muko-shi, Kyoto 617-0003, Japan

assumption of a small step size. This type of nonlinearity arises from class B amplifiers or nonlinear actuators. Tobias and Seara [28] explored modifications of the LMS algorithm designed to improve its performance in environments affected by erf saturation-type nonlinearity. Bershada [29] conducted an analysis on how the LMS algorithm is updated when it encounters erf saturation-type nonlinearity. Furthermore, Bershada [29] expanded this analysis to include the tracking of a Markov channel, specifically within the realm of system identification. As described thus far, numerous studies have been conducted on adaptive systems that include erf saturation-type nonlinearity. On the other hand, Hamidi *et al.* [30] conducted an analysis, alongside computer simulations and experimental studies, of an ANC model that incorporates an adaptive filter with clipping saturation-type nonlinearity. To increase the efficiency of the adaptive algorithm, they suggested altering the cost function to circumvent the use of this nonlinear region. Stenger and Kellermann [31] proposed clipping-type preprocessing in adaptive echo cancellation to mitigate the impacts of nonlinear echo paths.

Our research group’s recent exploration of using the statistical-mechanical method [35] to analyze adaptive signal processing represents a significant advance in handling the complexities of such systems. Conventional statistical analysis often relies on various approximations and assumptions to compute expectations concerning the input signal, which is inherently a random variable. However, the application of statistical-mechanical analysis enables a shift from this norm. Statistical–mechanical analysis enables the examination of universal properties of systems composed of numerous microscopic variables by assuming the large-system limit. This approach simplifies discussions to a few macroscopic variables, enabling a macroscopic and deterministic analysis. The benefits of this method are underscored by the applicability of the law of large numbers and the central limit theorem, which simplify many of the calculations involved. This method proves especially beneficial for analyzing signal processing tasks that incorporate adaptive filters with markedly long taps, which is typical in practical acoustic systems.

Our research group’s application [36,37] of the statistical-mechanical method to the analysis of feed-forward ANC systems updated by the Filtered-X LMS (FXLMS) algorithm represents an advanced approach in the field of adaptive signal processing. Initially, our analyses focused on systems in which the primary path, secondary path, and adaptive filter were linear [36,37]. By expanding this focus in recent work, our group [32–34] has ventured into more complex scenarios involving nonlinearities, specifically analyzing models with both the unknown system and adaptive filter incorporating the Volterra-type nonlinearity [38]. Although Volterra filters inherently exhibit nonlinear characteristics, adapting the statistical-mechanical method originally developed for linear systems to these filters has proven feasible. This adaptation, however, was limited to Volterra filters of a specific order, indicating a constraint in the versatility of the methodology. Additionally, the method has yet to address simpler yet commonly encountered nonlinearities in practical adaptive systems, such as those of the saturation and dead-zone types. These limitations highlight potential areas for further research and development within our group’s work, aiming to expand the applicability of the statistical-mechanical method to a broader range of nonlinear scenarios encountered in adaptive signal processing.

Nonlinear components within adaptive signal processing systems have been extensively explored, particularly regarding the saturation characteristics inherent in power amplifiers and transducers such as loudspeakers and microphones. The erf saturation-type nonlinearity has been thoroughly studied and well understood owing to its mathematical tractability. However, another critical form of nonlinearity, the clipping saturation type, which exhibits piecewise linear characteristics, has not been as extensively analyzed. Clipping saturation-type nonlinearity is crucial for accurately representing the saturation phenomena in adaptive systems. This type of nonlinearity is particularly challenging to model and analyze owing to its nondifferentiability. Costa *et al.* highlighted this in their study [27], in which they noted that to facilitate the development of analytical models, it is convenient to approximate the piecewise nonlinearity by a continuous and more mathematically tractable function. They [27] even validated the theoretical results of their erf-type nonlinearity with computer simulations that employed piecewise linearity, underscoring the practical relevance of such studies. Despite their importance, there remained a significant gap in the literature concerning the analytical study of clipping saturation-type nonlinearity. This gap indicated a potential area for future research, where more detailed analytical methods needed to be developed to better understand and predict the behavior of adaptive systems encountering this type of nonlinearity.

Based on the aforementioned background, Miyoshi [39] investigated the behaviors of an adaptive

system where the output of the adaptive filter exhibits clipping saturation-type nonlinearity using a statistical-mechanical approach. His analysis clarified the existence of a critical saturation value at which the system toggles between mean-square stability and instability. He also derived the exact value of this critical saturation.

Following these advancements, in this study, we perform a statistical-mechanical analysis of the behavior of an adaptive signal processing system where the output of the unknown system exhibits saturation-type nonlinearity, and separately, where it exhibits dead-zone-type nonlinearity. The main contributions of this paper are as follows:

- We explore the behavior of an adaptive signal processing system where the output of the unknown system exhibits saturation-type nonlinearity, and separately, where it exhibits dead-zone-type nonlinearity by applying a statistical-mechanical method. The work conducted by Miyoshi [39] can be seen as focusing on an active noise control model where nonlinearity was present in the adaptive filter. In contrast, our current study can be interpreted as shifting the focus to an acoustic echo canceller model, which is characterized by the presence of nonlinearity in the unknown system, not in the adaptive filter.
- For the adaptive signal processing system in which the unknown system is modeled by the FIR filter and the adaptive filter is composed of the FIR filter, the dynamical and steady-state behaviors of the mean square error (MSE) and the mean square deviation (MSD) are discussed deterministically under the long-filter assumption.
- We compare the behaviors of saturation-type and dead-zone-type nonlinearities. As a result, we interestingly found that the steady-state MSEs for the saturation and dead-zone types are exactly equal to each other. In addition, we obtain the self-consistent equation for the saturation and dead-zone values that maximize the steady-state MSEs.

The remainder of this paper is structured as follows. In Sect. 2, we provide details of the model, which is the focus of our study, laying out the foundational concepts and parameters involved. In Sect. 3, we describe a thorough statistical-mechanical analysis of the model, elaborating on the methodologies and techniques employed. In Sect. 4, we present the core findings of our research, with which we validate the theoretical model by comparing the theoretical predictions with numerical simulation data. Finally, in Sect. 5, we summarize the insights gained from our study and discuss the implications of our findings, concluding the paper with a summary of key outcomes and potential avenues for future research.

*Notation:* Scalars are denoted by lowercase italic fonts except for  $Q$ ,  $S$ ,  $D$ ,  $N$ ,  $M$ ,  $A_S$ , and  $A_D$ , which are also scalars in accordance with the conventions used in the corresponding literature. Column vectors are denoted by bold lowercase italic fonts and matrices by bold uppercase italic fonts. The superscripts  $\top$  and  $^{-1}$  denote transpose and inverse, respectively, whereas  $\langle \cdot \rangle$  stands for expectation. Finally, if  $\mathbf{z}$  is a column vector, then  $\|\mathbf{z}\|_2^2 = \mathbf{z}^\top \mathbf{z}$ .

## 2 Model

Fig. 1 illustrates a block diagram of the adaptive system studied. The impulse response of the unknown system  $\mathbf{G}$  is an  $M$ -dimensional arbitrary vector

$$\mathbf{g}_0 = [g_1, g_2, \dots, g_M]^\top, \quad (1)$$

and remains time-invariant. The adaptive filter  $\mathbf{W}$  is an  $N$ -tap FIR filter, characterized by its coefficient vector

$$\mathbf{w}(n) = [w_1(n), w_2(n), \dots, w_N(n)]^\top, \quad (2)$$

where  $n$  denotes the time step. Although the dimension  $M$  of  $\mathbf{g}_0$  is generally unknown in advance, we assume that the tap length  $N$  of the adaptive filter  $\mathbf{W}$  is set to satisfy

$$N \geq M, \quad (3)$$

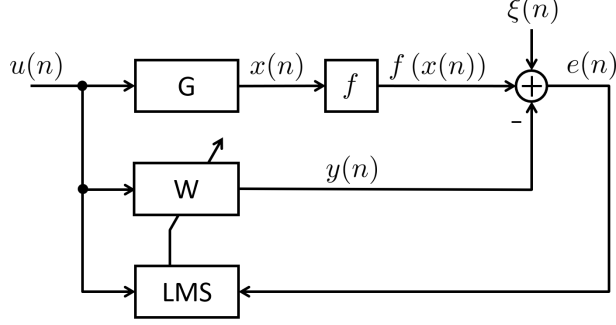

**Figure 1:** Block diagram of the adaptive system.

because it is straightforward to design an adaptive filter  $W$  of tap length  $N$  with a margin. Moreover, let  $\mathbf{g}$  be a vector expanded to  $N$  dimensions by appending  $N - M$  zeros to  $\mathbf{g}_0$ . That is,

$$\mathbf{g} = [g_1, g_2, \dots, g_M, g_{M+1}, \dots, g_N]^\top, \quad (4)$$

$$g_i = 0, \quad i = M + 1, \dots, N. \quad (5)$$

Note that although previous studies [22, 27–29] typically assume that the dimensions of  $\mathbf{g}_0$  and  $\mathbf{w}$  are equal, our model diverges from this assumption. It permits arbitrary  $\mathbf{g}_0$  dimensions and refrains from imposing strict constraints on its dimension  $M$  or its elements  $g_i, i = 1, \dots, M$ . We define the parameter  $\sigma_g^2$  as

$$\sigma_g^2 \triangleq \frac{1}{N} \|\mathbf{g}_0\|_2^2 = \frac{1}{N} \|\mathbf{g}\|_2^2 = \frac{1}{N} \sum_{i=1}^N g_i^2. \quad (6)$$

As will become clear later, our theory relies solely on the unknown system  $G$  through  $\sigma_g^2$ . To validate this assertion, we will present empirical results in Sect. 4, demonstrating the applicability of the theory to experimentally obtained  $\mathbf{g}_0$ .

The input signal  $u(n)$  is assumed to be independently drawn from a distribution with

$$\langle u(n) \rangle = 0, \quad \langle u(n)^2 \rangle = \sigma^2. \quad (7)$$

That is, the input signal is white. Although the assumption of a white input signal may appear restrictive, it holds significant relevance in practical scenarios, notably in system identification. In addition, analysis for white signals is crucial as a baseline. Furthermore, this model provides valuable insights into algorithm behavior and serves as a benchmark for alternative cases [22]. Note that only the mean and variance of the distribution are specified in (7). No specific distributions, such as the Gaussian distribution, are assumed. The tap input vector  $\mathbf{u}(n)$  at time step  $n$  is

$$\mathbf{u}(n) = [u(n), u(n-1), \dots, u(n-N+1)]^\top. \quad (8)$$

The expressions for  $x(n)$  and  $y(n)$  describe the outputs of the system  $G$  and the adaptive filter  $W$ , respectively, in terms of convolutions with their own coefficients and a sequence of input signals  $u(n)$ . That is,

$$x(n) = \mathbf{g}^\top \mathbf{u}(n) = \sum_{i=1}^N g_i u(n-i+1), \quad (9)$$

$$y(n) = \mathbf{w}(n)^\top \mathbf{u}(n) = \sum_{i=1}^N w_i(n) u(n-i+1). \quad (10)$$

The nonlinearity of the unknown system  $G$  is modeled by the function  $f$  placed after  $G$ . In this paper, the function  $f$  represents the saturation-type nonlinearity

$$f(x) = \begin{cases} S, & x > S \\ -S, & x < -S \\ x, & \text{otherwise} \end{cases} \quad (11)$$

and the dead-zone-type nonlinearity

$$f(x) = \begin{cases} x - D, & x > D \\ x + D, & x < -D \\ 0, & \text{otherwise} \end{cases} \quad (12)$$

Here,  $S$  and  $D$  are the saturation value and dead-zone width, respectively, and they are nonnegative real numbers. Fig. 2(a) and (b) illustrate the saturation-type and dead-zone-type nonlinearities, respectively. The dead-zone-type nonlinearity is also an important nonlinear function called the soft thresholding function. It is also utilized in reconstruction algorithms such as ISTA [40] and FISTA [41] for compressed sensing [42–44].

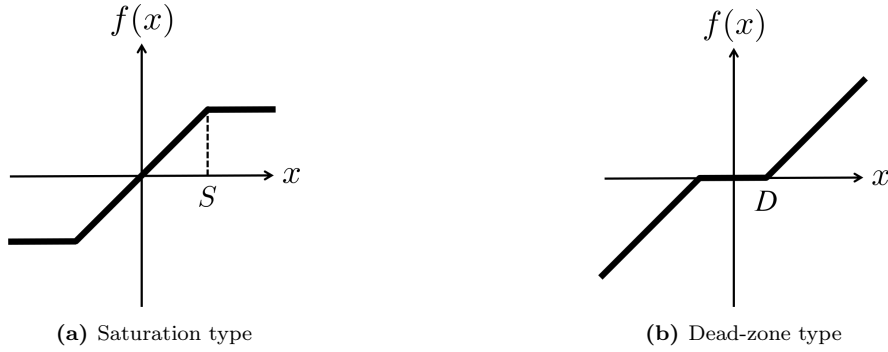

**Figure 2:** Two types of nonlinearity

The error signal, denoted as  $e(n)$ , is formulated by incorporating the independent background noise component  $\xi(n)$  into the difference between  $f(x(n))$  and  $y(n)$ . That is,

$$e(n) = f(x(n)) - y(n) + \xi(n). \quad (13)$$

In this analysis,  $\xi(n)$  is characterized solely by a mean of zero and a variance denoted as  $\sigma_\xi^2$ . It is important to emphasize that these parameters do not presuppose any specific probability distribution for the background noise, including but not limited to the Gaussian distribution.

The LMS algorithm [45] is employed to update the adaptive filter. That is,

$$\mathbf{w}(n+1) = \mathbf{w}(n) + \mu e(n) \mathbf{u}(n), \quad (14)$$

where  $\mu$  represents the step size, which is a positive real number.

### 3 Analysis

In this section, we conduct a theoretical analysis using the statistical-mechanical method to compare the behaviors of the adaptive system in two separate scenarios: one with saturation-type nonlinearity and the other with dead-zone-type nonlinearity. From (13), the MSE is expressed as

$$\langle e^2 \rangle = \langle (f(x) - y + \xi)^2 \rangle \quad (15)$$

$$= \langle f(x)^2 \rangle + \langle y^2 \rangle - 2 \langle f(x)y \rangle + \sigma_\xi^2. \quad (16)$$

In this section, we omit the time step  $n$  unless otherwise stated to avoid cumbersome notation. We assume  $N \rightarrow \infty^1$  while keeping

$$\rho^2 \triangleq N\sigma^2 \quad (17)$$

constant, in accordance with the statistical-mechanical method [35]. The normalized LMS (NLMS) algorithm [1, 2] is a significant variant of the LMS algorithm. The update rule of the NLMS algorithm is detailed as follows:

$$\mathbf{w}(n+1) = \mathbf{w}(n) + \frac{\tilde{\mu}}{\|\mathbf{u}(n)\|_2^2} e(n)\mathbf{u}(n), \quad (18)$$

where  $\tilde{\mu}$  is the step size. Given that  $\|\mathbf{u}(n)\|_2^2 = N\sigma^2 = \rho^2$ , the present analysis is equivalent to the analysis of the NLMS algorithm where  $\tilde{\mu} = \rho^2\mu$  serves as the step size for a stationary input signal  $u(n)$ . Then, according to the central limit theorem, both  $x$  and  $y$  are stochastic variables that follow the Gaussian distribution. Their means are zero, and their variance–covariance matrix is

$$\Sigma \triangleq \rho^2 \begin{pmatrix} \sigma_g^2 & r \\ r & Q \end{pmatrix}, \quad (19)$$

[39]. Here,  $r$  and  $Q$  are macroscopic variables that are respectively defined as

$$r \triangleq \frac{1}{N} \mathbf{g}^\top \mathbf{w}, \quad (20)$$

$$Q \triangleq \frac{1}{N} \mathbf{w}^\top \mathbf{w}. \quad (21)$$

The derivation of the means and variance–covariance matrix is given in detail in Appendix A.

We obtain three sample means in (16) as follows:

- Saturation type

$$\begin{aligned} \langle f(x)^2 \rangle &= S^2 - S\sqrt{\frac{2\rho^2\sigma_g^2}{\pi}} \exp\left(-\frac{S^2}{2\rho^2\sigma_g^2}\right) \\ &\quad + (\rho^2\sigma_g^2 - S^2) \operatorname{erf}\left(\frac{S}{\sqrt{2\rho^2\sigma_g^2}}\right), \end{aligned} \quad (22)$$

$$\langle y^2 \rangle = \rho^2 Q, \quad (23)$$

$$\langle f(x)y \rangle = \rho^2 r \operatorname{erf}\left(\frac{S}{\sqrt{2\rho^2\sigma_g^2}}\right), \quad (24)$$

- Dead-zone type

$$\begin{aligned} \langle f(x)^2 \rangle &= (D^2 + \rho^2\sigma_g^2) \left(1 - \operatorname{erf}\left(\frac{D}{\sqrt{2\rho^2\sigma_g^2}}\right)\right) \\ &\quad - D\sqrt{\frac{2\rho^2\sigma_g^2}{\pi}} \exp\left(-\frac{D^2}{2\rho^2\sigma_g^2}\right), \end{aligned} \quad (25)$$

$$\langle y^2 \rangle = \rho^2 Q, \quad (26)$$

$$\langle f(x)y \rangle = \rho^2 r \left(1 - \operatorname{erf}\left(\frac{D}{\sqrt{2\rho^2\sigma_g^2}}\right)\right), \quad (27)$$

---

<sup>1</sup>This is called *the thermodynamic limit* in statistical mechanics.

where  $\text{erf}(\cdot)$  is an error function defined as

$$\text{erf}(x) \triangleq \frac{2}{\sqrt{\pi}} \int_0^x \exp(-\tau^2) d\tau. \quad (28)$$

Equation (23) is readily obtained from (19). Equations (22) and (24) are derived in detail in Appendices B and C, respectively. The details of the calculation of sample averages that appear thereafter are omitted, but they can be obtained using almost identical calculations.

Substituting (22)–(24) or (25)–(27) into (16), we obtain the MSE for the saturation and dead-zone types, respectively. In both scenarios, the MSE depends on the macroscopic variables  $r$  and  $Q$ . Therefore, we formulate differential equations to characterize the dynamical behaviors of these variables in the following. Multiplying both sides of (14) on the left by  $\mathbf{g}^\top$  and using (20), we obtain

$$Nr(n+1) = Nr(n) + \mu e(n)x(n). \quad (29)$$

We introduce time  $t$  defined by

$$t \triangleq \frac{n}{N} \quad (30)$$

and use it to represent the adaptive process. Then,  $t$  transitions to a continuous variable since the limit  $N \rightarrow \infty$  is considered. This approach is consistent with the methods used in the statistical-mechanical analysis of online learning [46].

If the adaptive filter is updated  $Ndt$  times in an infinitely small time  $dt$ , we can obtain  $Ndt$  equations as

$$Nr(n+1) = Nr(n) + \mu e(n)x(n), \quad (31)$$

$$Nr(n+2) = Nr(n+1) + \mu e(n+1)x(n+1), \quad (32)$$

$$\vdots \quad \vdots \quad \vdots$$

$$Nr(n+Ndt) = Nr(n+Ndt-1) + \mu e(n+Ndt-1)x(n+Ndt-1). \quad (33)$$

Summing all these equations, we obtain

$$Nr(n+Ndt) = Nr(n) + \mu \sum_{n'=n}^{n+Ndt-1} e(n')x(n'). \quad (34)$$

Therefore, we obtain

$$N(r+dr) = Nr + Ndt\mu \langle ex \rangle. \quad (35)$$

Here, drawing from the law of large numbers, we have represented the effect of probabilistic variables through their means, considering that updates occur  $Ndt$  times – numerous occasions that result in the increase in  $r$  by  $dr$ . This property is called *self-averaging* in statistical mechanics [35]. From (13) and (35), we derive a differential equation that systematically outlines the deterministic dynamics of  $r$  as follows:

$$\frac{dr}{dt} = \mu \left( \langle f(x)x \rangle - \langle xy \rangle \right). \quad (36)$$

Next, by squaring both sides of (14) and applying the method used to derive the differential equation for  $r$ , we successfully derive a differential equation for  $Q$ . The derived equation is expressed as

$$\begin{aligned} \frac{dQ}{dt} &= \mu^2 \rho^2 \left( \langle f(x)^2 \rangle - 2 \langle f(x)y \rangle + \langle y^2 \rangle + \sigma_\xi^2 \right) \\ &\quad + 2\mu \left( \langle f(x)y \rangle - \langle y^2 \rangle \right). \end{aligned} \quad (37)$$

In this analysis, we leverage the fact that as  $N \rightarrow \infty$ , the term  $\mathbf{u}^\top \mathbf{u} = \|\mathbf{u}\|_2^2 = \sum_{i=1}^N u(n-i+1)^2$  transitions from a random variable to a constant value  $\rho^2 = N\sigma^2$ . This transition is supported by the law of large numbers, which allows  $\mathbf{u}^\top \mathbf{u}$  to be consistently treated as a constant outside the expectation operation  $\langle \cdot \rangle$ . This approach highlights a significant advantage of the statistical-mechanical method in scenarios where  $N \rightarrow \infty$ , enabling simplifications that are not apparent under finite conditions.

Equations (36) and (37) include five sample means. However, because three of the five means are already given in (22)–(24) or (25)–(27), we similarly obtain the two remaining means as follows:

- Saturation type

$$\langle xy \rangle = \rho^2 r, \quad (38)$$

$$\langle f(x)x \rangle = \rho^2 \sigma_g^2 \operatorname{erf} \left( \frac{S}{\sqrt{2\rho^2 \sigma_g^2}} \right), \quad (39)$$

- Dead-zone type

$$\langle xy \rangle = \rho^2 r, \quad (40)$$

$$\langle f(x)x \rangle = \rho^2 \sigma_g^2 \left( 1 - \operatorname{erf} \left( \frac{D}{\sqrt{2\rho^2 \sigma_g^2}} \right) \right). \quad (41)$$

Substituting (22)–(24), (38), and (39) or (25)–(27), (40), and (41) into (36) and (37), we obtain the concrete formulas of the simultaneous differential equations for the saturation or dead-zone type. By analytically solving the derived simultaneous differential equations, we can explicitly obtain the macroscopic variables as follows:

- Saturation type

$$r(t) = \sigma_g^2 \operatorname{erf} \left( \frac{S}{\sqrt{2\rho^2 \sigma_g^2}} \right) \left( 1 - \exp(-\mu\rho^2 t) \right), \quad (42)$$

$$\begin{aligned} Q(t) &= -2\sigma_g^2 \operatorname{erf} \left( \frac{S}{\sqrt{2\rho^2 \sigma_g^2}} \right)^2 \exp(-\mu\rho^2 t) \\ &\quad + A_S \exp(-\mu\rho^2 (2 - \mu\rho^2) t) \\ &\quad + 2\sigma_g^2 \operatorname{erf} \left( \frac{S}{\sqrt{2\rho^2 \sigma_g^2}} \right)^2 - A_S, \end{aligned} \quad (43)$$

$$\begin{aligned} A_S &= \frac{1}{2 - \mu\rho^2} \left[ 2\sigma_g^2 \operatorname{erf} \left( \frac{S}{\sqrt{2\rho^2 \sigma_g^2}} \right)^2 \right. \\ &\quad \left. - \mu \left( S^2 \left( 1 - \operatorname{erf} \left( \frac{S}{\sqrt{2\rho^2 \sigma_g^2}} \right) \right) \right) \right. \\ &\quad \left. + \rho^2 \sigma_g^2 \operatorname{erf} \left( \frac{S}{\sqrt{2\rho^2 \sigma_g^2}} \right) \right. \\ &\quad \left. - S \sqrt{\frac{2\rho^2 \sigma_g^2}{\pi}} \exp \left( -\frac{S^2}{2\rho^2 \sigma_g^2} \right) + \sigma_\xi^2 \right], \end{aligned} \quad (44)$$



- Dead-zone type

$$r(t) = \sigma_g^2 \left( 1 - \operatorname{erf} \left( \frac{D}{\sqrt{2\rho^2\sigma_g^2}} \right) \right) \times \left( 1 - \exp(-\mu\rho^2 t) \right), \quad (45)$$

$$Q(t) = -2\sigma_g^2 \left( 1 - \operatorname{erf} \left( \frac{D}{\sqrt{2\rho^2\sigma_g^2}} \right) \right)^2 \exp(-\mu\rho^2 t) + A_D \exp(-\mu\rho^2(2-\mu\rho^2)t) + 2\sigma_g^2 \left( 1 - \operatorname{erf} \left( \frac{D}{\sqrt{2\rho^2\sigma_g^2}} \right) \right)^2 - A_D, \quad (46)$$

$$A_D = \frac{1}{2-\mu\rho^2} \left[ 2\sigma_g^2 \left( 1 - \operatorname{erf} \left( \frac{D}{\sqrt{2\rho^2\sigma_g^2}} \right) \right)^2 - \mu \left( D^2 \left( 1 - \operatorname{erf} \left( \frac{D}{\sqrt{2\rho^2\sigma_g^2}} \right) \right) \right) + \rho^2\sigma_g^2 \left( 1 - \operatorname{erf} \left( \frac{D}{\sqrt{2\rho^2\sigma_g^2}} \right) \right) - D\sqrt{\frac{2\rho^2\sigma_g^2}{\pi}} \exp\left(-\frac{D^2}{2\rho^2\sigma_g^2}\right) + \sigma_\xi^2 \right]. \quad (47)$$

Note that the simultaneous differential equations obtained by substituting (22)–(24), (38), and (39) or (25)–(27), (40), and (41) into (36) and (37) can be solved analytically, since their right-hand sides are linear expressions for  $r$  and  $Q$ . This is in contrast to our group's analyses for active noise control [36,37,39], where the differential equation could not be solved analytically and had to be solved numerically.

Upon closer examination of the terms involving time  $t$  in (42), (43), (45), and (46), it becomes evident that  $r$  and  $Q$  exhibit two distinct time constants, that is,  $(\mu\rho^2)^{-1}$  and  $(\mu\rho^2(2-\mu\rho^2))^{-1}$ . Substituting the obtained analytical solution (42)–(44) into (16) and (22)–(24) yields the analytical MSE for the saturation type, while substituting (45)–(47) into (16) and (25)–(27) yields the analytical MSE for the dead-zone type as follows:

- Saturation type

$$\begin{aligned} \text{MSE}(t) &= \rho^2 A_S \exp(-\mu\rho^2(2-\mu\rho^2)t) \\ &+ \frac{2\rho^2\sigma_g^2}{2-\mu\rho^2} \left[ \left( 1 - \operatorname{erf} \left( \frac{S}{\sqrt{2\rho^2\sigma_g^2}} \right) \right) \right. \\ &\quad \times \left( \frac{S^2}{\rho^2\sigma_g^2} + \operatorname{erf} \left( \frac{S}{\sqrt{2\rho^2\sigma_g^2}} \right) \right) \\ &\quad \left. - \sqrt{\frac{2S^2}{\pi\rho^2\sigma_g^2}} \exp\left(-\frac{S^2}{2\rho^2\sigma_g^2}\right) \right] + \frac{2}{2-\mu\rho^2} \sigma_\xi^2, \end{aligned} \quad (48)$$

- Dead-zone type

$$\begin{aligned}
\text{MSE}(t) &= \rho^2 A_D \exp(-\mu\rho^2(2 - \mu\rho^2)t) \\
&+ \frac{2\rho^2\sigma_g^2}{2 - \mu\rho^2} \left[ \left( 1 - \operatorname{erf} \left( \frac{D}{\sqrt{2\rho^2\sigma_g^2}} \right) \right) \right. \\
&\quad \times \left( \frac{D^2}{\rho^2\sigma_g^2} + \operatorname{erf} \left( \frac{D}{\sqrt{2\rho^2\sigma_g^2}} \right) \right) \\
&\quad \left. - \sqrt{\frac{2D^2}{\pi\rho^2\sigma_g^2}} \exp \left( -\frac{D^2}{2\rho^2\sigma_g^2} \right) \right] + \frac{2}{2 - \mu\rho^2} \sigma_\xi^2. \tag{49}
\end{aligned}$$

The first terms in (48) and (49) are dependent upon time  $t$ . By closely examining the terms, it becomes apparent that MSEs contain only one time constant, that is,  $(\mu\rho^2(2 - \mu\rho^2))^{-1}$ . The difference between  $A_S$  and  $A_D$  is the cause of the difference in learning curves shown in Sect. 4. From (48) and (49), it is easy to see that the condition for MSE convergence is

$$0 < \mu < \frac{2}{\rho^2}. \tag{50}$$

If this condition is satisfied, the first terms in (48) and (49) converge to zero.

From (20) and (21), we can also obtain the MSD, or misalignment, as a function of the macroscopic variables  $r$  and  $Q$  as follows:

$$\text{MSD} = \|\mathbf{g} - \mathbf{w}\|_2^2 \tag{51}$$

$$= \|\mathbf{g}\|_2^2 - 2\mathbf{g}^\top \mathbf{w} + \|\mathbf{w}\|_2^2 \tag{52}$$

$$= N(\sigma_g^2 - 2r + Q). \tag{53}$$

Equation (53) indicates that the MSD is proportional to the tap length  $N$  within the context of the model discussed in this research. Therefore, the MSD is normalized by the tap length. This adjusted metric is referred to as the normalized MSD.

By substituting  $t \rightarrow \infty$  into (48) and (49), the first terms converge to zero if (50) is satisfied and we can obtain the steady-state MSE for the saturation or dead-zone type, respectively.

Interestingly, the steady-state MSEs for the saturation and dead-zone types, that is, the second terms in (48) and (49), are exactly equal to each other as follows:

$$\begin{aligned}
\text{MSE}(\infty) &= \frac{2\rho^2\sigma_g^2}{2 - \mu\rho^2} \left[ \left( 1 - \operatorname{erf} \left( \frac{\square}{\sqrt{2\rho^2\sigma_g^2}} \right) \right) \right. \\
&\quad \times \left( \frac{\square^2}{\rho^2\sigma_g^2} + \operatorname{erf} \left( \frac{\square}{\sqrt{2\rho^2\sigma_g^2}} \right) \right) \\
&\quad \left. - \sqrt{\frac{2\square^2}{\pi\rho^2\sigma_g^2}} \exp \left( -\frac{\square^2}{2\rho^2\sigma_g^2} \right) \right] + \frac{2}{2 - \mu\rho^2} \sigma_\xi^2. \tag{54}
\end{aligned}$$

Here,  $\square$  is  $S$  or  $D$  for the saturation or dead-zone type, respectively. Equation (54) indicates that the background noise is enhanced by  $\frac{2}{2 - \mu\rho^2}$  and that  $\square$  is included in the form  $\frac{\square}{\rho\sigma_g}$ .

Putting the partial differentiation of (54) with  $\square$  as zero, we obtain the self-consistent equation for  $S$  and  $D$  that maximize the steady-state MSE as follows:

$$\left( 1 + \sqrt{\frac{2\rho^2\sigma_g^2}{\pi\square^2}} \exp \left( -\frac{\square^2}{2\rho^2\sigma_g^2} \right) \right) \operatorname{erf} \left( \frac{\square}{\sqrt{2\rho^2\sigma_g^2}} \right) = 1. \tag{55}$$

It can be seen that (55) is an equation for  $\frac{\square}{\rho\sigma_g}$ . Although this equation cannot be solved analytically, a numerical solution reveals that the condition that maximizes the steady-state MSE is

$$\frac{\square}{\rho\sigma_g} \simeq 0.8485. \quad (56)$$

Note that  $S$  and  $D$  that maximize the steady-state MSE depend on neither the step size  $\mu$  nor the variance  $\sigma_\xi^2$  of background noise because (55) does not include them.

## 4 Results and Discussion

### 4.1 Learning curves

We begin by examining the validity of the theory by comparing theoretical calculation results with simulation results, focusing on the dynamic behavior of the MSE, namely, the learning curves. Figs. 3 and 4 show the learning curves of the saturation and dead-zone types, respectively. In these figures, the thick curves are the theoretical calculation results, whereas the thin polygonal lines are the simulation results. For both theoretical calculations and computer simulations, we set  $\rho^2 = \sigma_g^2 = 1$ . In the theoretical calculations, the results in Figs. 3 and 4 correspond exactly to (48) and (49), respectively. In the computer simulations, the adaptive filter  $W$  consists of 400 taps ( $N = 400$ ), and the ensemble averages over 1000 trials are plotted.

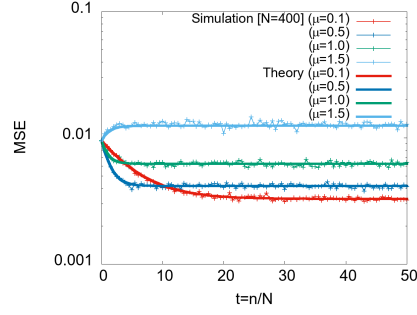

(a)  $S = 0.1$

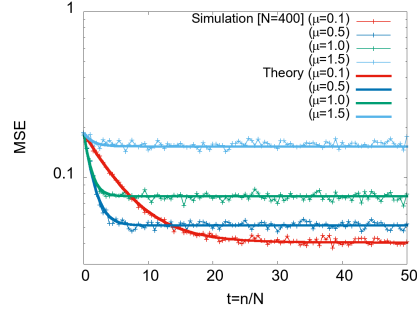

(b)  $S = 0.5$

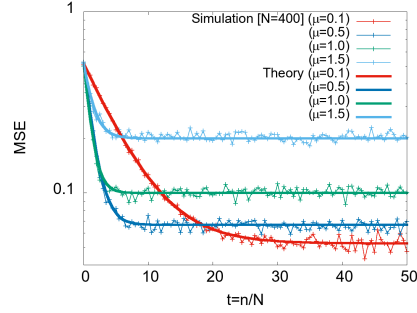

(c)  $S = 1.0$

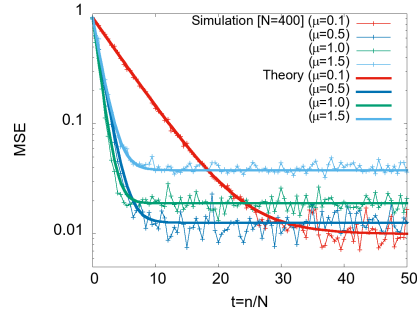

(d)  $S = 2.0$

**Figure 3:** Learning curves (saturation type).

The impulse response  $\mathbf{g}_0$  of the unknown system  $G$  in all computer simulations in this paper was obtained from experimental measurements. It is depicted in Fig. 5. Its dimension  $M$  is 256. Note that  $\mathbf{g}_0$  has been normalized to meet the condition given in (6). In the simulations, all initial coefficient values  $w_i(0)$ ,  $i = 1, \dots, N$  are set to zero. Similarly, the initial conditions  $r(0) = Q(0) = 0$  are applied in the theoretical calculations. Figs. 3 and 4 indicate that the theoretical results derived in this paper align well with the simulation results in terms of average values. Note, perhaps unsurprisingly, that, the learning

curves for the saturation and dead-zone types are not the same, even if  $S = D$ .

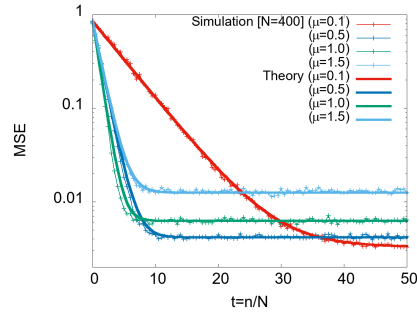

(a)  $D = 0.1$

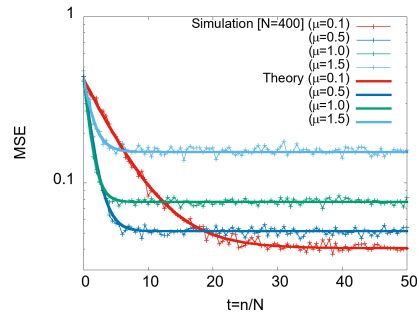

(b)  $D = 0.5$

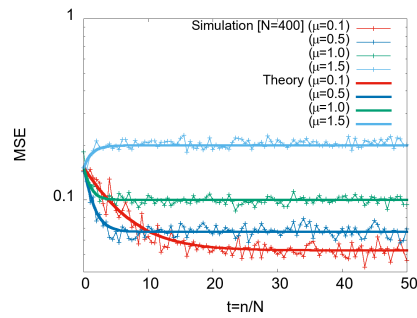

(c)  $D = 1.0$

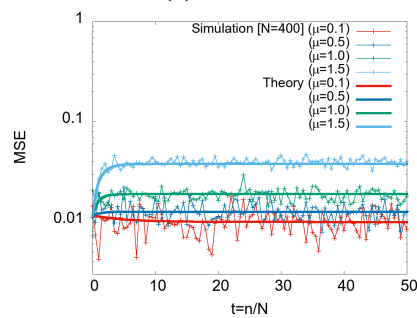

(d)  $D = 2.0$

**Figure 4:** Learning curves (dead-zone type).

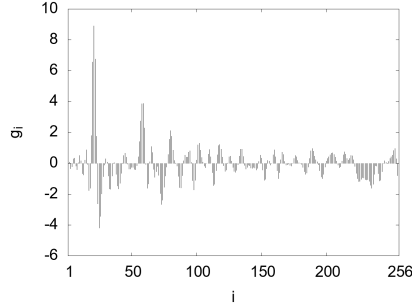

**Figure 5:** Impulse response  $g_0$  of the unknown system  $G$  used in all computer simulations in this paper.

## 4.2 Steady state

Fig. 6 presents the steady-state MSE values obtained by the theoretical calculations for both the saturation and dead-zone types, together with the corresponding simulation results at  $t = 200$ . This simulation time is adequate for the MSEs to reach their steady-state values. In the computer simulations, the adaptive filter  $W$  has 400 taps ( $N = 400$ ). For these simulations, error bars indicate the medians and standard deviations based on 100 trials.

Although learning curves for the saturation and dead-zone types are different, even if  $S = D$ , as shown in Figs. 3 and 4, the steady-state MSEs for the saturation and dead-zone types are exactly equal to each other, as revealed in (54). Therefore, the thick curves, that is, the theoretical calculation results, in Figs. 6(a) and (b) are, of course, identical. It is easily seen from (54) that if there is no background noise, that is,  $\sigma_\xi^2 = 0$ , the steady-state MSE is zero when  $S, D = 0$  or  $S, D \rightarrow \infty$ . These results are also seen in Fig. 6. If  $S \rightarrow \infty$  or  $D = 0$ ,  $f(x)$  is a linear function; therefore, it is reasonable that the steady-state MSE is zero. On the other hand, if  $S = 0$  or  $D \rightarrow \infty$ ,  $f(x)$  is always zero; therefore, the output  $y$  of the adaptive filter  $W$  also becomes zero when  $t \rightarrow \infty$ . As a result, the MSE becomes zero. Here, in Fig. 6, the steady-state MSEs are maximum at  $\frac{S}{\rho\sigma_g}, \frac{D}{\rho\sigma_g} \simeq 0.8485$ , as revealed in (56).

Fig. 7 shows the steady-state normalized MSDs for the saturation and dead-zone types. Although the steady-state MSEs for the saturation and dead-zone types are exactly equal to each other, as revealed in (54) and Fig. 6, the steady-state normalized MSDs are different. That is, even if  $S = D$ , the relationship between the coefficient vector of the adaptive filter and that of the unknown system is not the same for the saturation type compared to the dead-zone type.

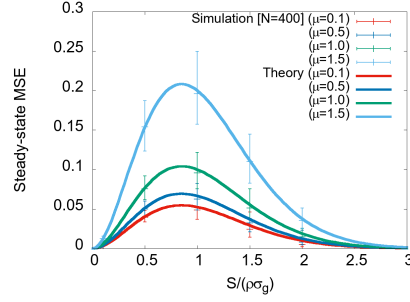

(a) Saturation type

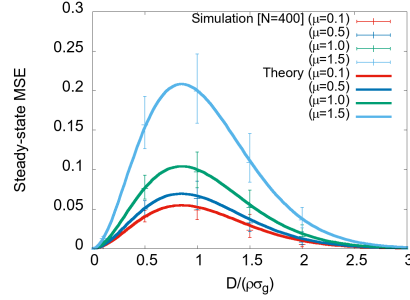

(b) Dead-zone type

Figure 6: Steady-state MSE.

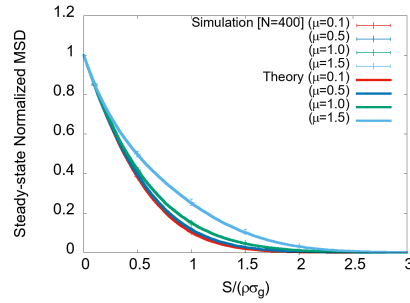

(a) Saturation type

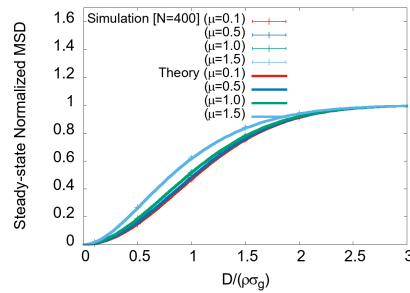

(b) Dead-zone type

Figure 7: Steady-state normalized MSD.

## 5 Conclusions

In this paper, we have used the statistical-mechanical method to analyze the behaviors of adaptive systems with nonlinearities in the output of unknown systems. We have treated two types of nonlinearity, that is, the saturation-type and dead-zone-type nonlinearities. We have discussed the dynamical and steady-state behaviors of the adaptive systems. The analysis has revealed that the steady-state MSEs of both types are exactly the same when the saturation value and the dead-zone width are the same. The self-consistent equation, which the saturation value and dead-zone width satisfy when the steady-state MSE is maximized, has also been obtained.

A more in-depth discussion of why their steady-state MSEs are in exact agreement when the saturation value and the dead-zone width are equal and determining a more general condition for the steady-state MSEs to be in exact agreement are some of the future issues that will be studied.

## Acknowledgment

The authors wish to thank Professor Yoshinobu Kajikawa for providing the actual data of the experimentally measured impulse responses.

## A Derivation of means and variance–covariance matrix of $x$ and $y$

From (6), (7), (9), (10), (17), (20), and (21), we obtain the means, variances, and covariance of  $x$  and  $y$  as follows:

$$\langle x \rangle = \left\langle \sum_{i=1}^N g_i u(n-i+1) \right\rangle \quad (57)$$

$$= \sum_{i=1}^N g_i \langle u(n-i+1) \rangle = 0, \quad (58)$$

$$\langle y \rangle = \left\langle \sum_{i=1}^N w_i u(n-i+1) \right\rangle \quad (59)$$

$$= \sum_{i=1}^N w_i \langle u(n-i+1) \rangle = 0, \quad (60)$$

$$\langle x^2 \rangle = \left\langle \left( \sum_{i=1}^N g_i u(n-i+1) \right)^2 \right\rangle \quad (61)$$

$$= \left\langle \sum_{i=1}^N \sum_{j=1}^N g_i g_j u(n-i+1) u(n-j+1) \right\rangle \quad (62)$$

$$= \sum_{i=1}^N g_i^2 \langle u(n-i+1)^2 \rangle \quad (63)$$

$$= \sigma^2 \sum_{i=1}^N g_i^2 \xrightarrow{N \rightarrow \infty} \rho^2 \sigma_g^2, \quad (64)$$



$$\langle y^2 \rangle = \left\langle \left( \sum_{i=1}^N w_i u(n-i+1) \right)^2 \right\rangle \quad (65)$$

$$= \left\langle \sum_{i=1}^N \sum_{j=1}^N w_i w_j u(n-i+1) u(n-j+1) \right\rangle \quad (66)$$

$$= \sum_{i=1}^N w_i^2 \langle u(n-i+1)^2 \rangle \quad (67)$$

$$= \sigma^2 \sum_{i=1}^N w_i^2 \xrightarrow{N \rightarrow \infty} \rho^2 Q, \quad (68)$$

$$\langle xy \rangle = \left\langle \left( \sum_{i=1}^N g_i u(n-i+1) \right) \left( \sum_{j=1}^N w_j u(n-j+1) \right) \right\rangle \quad (69)$$

$$= \left\langle \sum_{i=1}^N \sum_{j=1}^N g_i w_j u(n-i+1) u(n-j+1) \right\rangle \quad (70)$$

$$= \sum_{i=1}^N g_i w_i \langle u(n-i+1)^2 \rangle \quad (71)$$

$$= \sigma^2 \sum_{i=1}^N g_i w_i \xrightarrow{N \rightarrow \infty} \rho^2 r. \quad (72)$$

From (58)–(72), the covariance matrix of  $x$  and  $y$  is (19). Here, (60), (68), and (72) were derived assuming that the correlation between  $\mathbf{w}(n)$  and  $\mathbf{u}(n)$  is small [24, 47, 48]. This assumption is a standard assumption used to analyze many adaptive algorithms [1, 2].

## B Derivation of (22)

$$\langle f(x)^2 \rangle = \int_{-\infty}^{\infty} dx f(x)^2 p(x) \quad (73)$$

$$= \left( \int_{-\infty}^{-S} + \int_{-S}^S + \int_S^{\infty} \right) dx f(x)^2 \times \frac{1}{\sqrt{2\pi\rho^2\sigma_g^2}} \exp\left(-\frac{x^2}{2\rho^2\sigma_g^2}\right) \quad (74)$$

$$= 2 \left( \underbrace{\int_S^{\infty} dx S^2 \frac{1}{\sqrt{2\pi\rho^2\sigma_g^2}} \exp\left(-\frac{x^2}{2\rho^2\sigma_g^2}\right)}_{B1} + \underbrace{\int_0^S dx x^2 \frac{1}{\sqrt{2\pi\rho^2\sigma_g^2}} \exp\left(-\frac{x^2}{2\rho^2\sigma_g^2}\right)}_{B2} \right), \quad (75)$$

$$B1 = \int_S^\infty dx S^2 \frac{1}{\sqrt{2\pi\rho^2\sigma_g^2}} \exp\left(-\frac{x^2}{2\rho^2\sigma_g^2}\right) \quad (76)$$

$$= \frac{S^2}{\sqrt{\pi}} \int_{\frac{S}{\sqrt{2\rho^2\sigma_g^2}}}^\infty dx' \exp(-x'^2),$$

$$\text{where } x' = \frac{x}{\sqrt{2\rho^2\sigma_g^2}}$$

$$= \frac{S^2}{\sqrt{\pi}} \left( \frac{\sqrt{\pi}}{2} - \int_0^{\frac{S}{\sqrt{2\rho^2\sigma_g^2}}} dx \exp(-x^2) \right)$$

$$\left( \because \int_0^\infty dx \exp(-x^2) = \frac{\sqrt{\pi}}{2} \right)$$

$$= \frac{S^2}{2} \left( 1 - \operatorname{erf}\left(\frac{S}{\sqrt{2\rho^2\sigma_g^2}}\right) \right), \quad (77)$$

$$B2 = \int_0^S dx x^2 \frac{1}{\sqrt{2\pi\rho^2\sigma_g^2}} \exp\left(-\frac{x^2}{2\rho^2\sigma_g^2}\right) \quad (78)$$

$$= \left[ -x \sqrt{\frac{\rho^2\sigma_g^2}{2\pi}} \exp\left(-\frac{x^2}{2\rho^2\sigma_g^2}\right) \right]_0^S$$

$$+ \sqrt{\frac{\rho^2\sigma_g^2}{2\pi}} \int_0^S dx \exp\left(-\frac{x^2}{2\rho^2\sigma_g^2}\right),$$

where we used integration by parts

$$= -S \sqrt{\frac{\rho^2\sigma_g^2}{2\pi}} \exp\left(-\frac{S^2}{2\rho^2\sigma_g^2}\right)$$

$$+ \frac{\rho^2\sigma_g^2}{2} \int_0^{\frac{S}{\sqrt{2\rho^2\sigma_g^2}}} dx' \exp(-x'^2),$$

$$\text{where } x' = \frac{x}{\sqrt{2\rho^2\sigma_g^2}}$$

$$= -S \sqrt{\frac{\rho^2\sigma_g^2}{2\pi}} \exp\left(-\frac{S^2}{2\rho^2\sigma_g^2}\right) + \frac{\rho^2\sigma_g^2}{2} \operatorname{erf}\left(\frac{S}{\sqrt{2\rho^2\sigma_g^2}}\right), \quad (79)$$

$$\therefore \langle f(x)^2 \rangle = 2(B1 + B2) \quad (80)$$

$$= S^2 - S \sqrt{\frac{2\rho^2\sigma_g^2}{\pi}} \exp\left(-\frac{S^2}{2\rho^2\sigma_g^2}\right)$$

$$+ (\rho^2\sigma_g^2 - S^2) \operatorname{erf}\left(\frac{S}{\sqrt{2\rho^2\sigma_g^2}}\right). \quad (81)$$

## C Derivation of (24)

$$\begin{aligned}
 \langle f(x)y \rangle &= \int_{-\infty}^{\infty} \int_{-\infty}^{\infty} dy dx f(x) y p(x, y) & (82) \\
 &= \underbrace{\int_{-\infty}^{\infty} dy y \int_{-\infty}^{-S} dx (-S) p(x, y)}_{C1} \\
 &\quad + \underbrace{\int_{-\infty}^{\infty} dy y \int_{-S}^S dx x p(x, y)}_{C2} \\
 &\quad + \underbrace{\int_{-\infty}^{\infty} dy y \int_S^{\infty} dx S p(x, y)}_{C3}, & (83)
 \end{aligned}$$

$$\begin{aligned}
C2 &= \int_{-\infty}^{\infty} dy y \int_{-S}^S dx x \frac{1}{2\pi \sqrt{\left| \rho^2 \begin{pmatrix} \sigma_g^2 & r \\ r & Q \end{pmatrix} \right|}} \\
&\times \exp \left( - \frac{\begin{pmatrix} x & y \end{pmatrix} \left( \rho^2 \begin{pmatrix} \sigma_g^2 & r \\ r & Q \end{pmatrix} \right)^{-1} \begin{pmatrix} x \\ y \end{pmatrix}}{2} \right) \tag{84}
\end{aligned}$$

$$\begin{aligned}
&= \int_{-\infty}^{\infty} dy y \int_{-S}^S dx x \frac{1}{2\pi \rho^2 \sqrt{Q\sigma_g^2 - r^2}} \\
&\times \exp \left( - \frac{\sigma_g^2 y^2 - 2rxy + Qx^2}{2\rho^2 (Q\sigma_g^2 - r^2)} \right) \tag{85}
\end{aligned}$$

$$\begin{aligned}
&= \int_{-\infty}^{\infty} dy y \int_{-S}^S dx x \frac{1}{2\pi \rho^2 \sqrt{Q\sigma_g^2 - r^2}} \\
&\times \exp \left( - \frac{\sigma_g^2 \left( y - \frac{r}{\sigma_g^2} x \right)^2 + \left( Q - \frac{r^2}{\sigma_g^2} \right) x^2}{2\rho^2 (Q\sigma_g^2 - r^2)} \right) \tag{86}
\end{aligned}$$

$$\begin{aligned}
&= \int_{-S}^S dx x \exp \left( - \frac{x^2}{2\rho^2 \sigma_g^2} \right) \int_{-\infty}^{\infty} dy y \\
&\times \frac{1}{2\pi \rho^2 \sqrt{Q\sigma_g^2 - r^2}} \exp \left( - \frac{\left( y - \frac{r}{\sigma_g^2} x \right)^2}{2\rho^2 \left( Q - \frac{r^2}{\sigma_g^2} \right)} \right) \tag{87}
\end{aligned}$$

$$\begin{aligned}
&= \int_{-S}^S dx x \exp \left( - \frac{x^2}{2\rho^2 \sigma_g^2} \right) \int_{-\infty}^{\infty} \sqrt{2\rho^2 \left( Q - \frac{r^2}{\sigma_g^2} \right)} \\
&\times dy' \left( \sqrt{2\rho^2 \left( Q - \frac{r^2}{\sigma_g^2} \right)} y' + \frac{r}{\sigma_g^2} x \right) \\
&\times \frac{1}{2\pi \rho^2 \sqrt{Q\sigma_g^2 - r^2}} \exp(-y'^2),
\end{aligned}$$

$$\text{where } y' = \frac{y - \frac{r}{\sigma_g^2} x}{\sqrt{2\rho^2 \left( Q - \frac{r^2}{\sigma_g^2} \right)}}$$

$$\begin{aligned}
&= \int_{-S}^S dx x \exp\left(-\frac{x^2}{2\rho^2\sigma_g^2}\right) \int_{-\infty}^{\infty} 2\rho^2 \left(Q - \frac{r^2}{\sigma_g^2}\right) \\
&\quad \times dy y \frac{1}{2\pi\rho^2\sqrt{Q\sigma_g^2 - r^2}} \exp(-y^2) \\
&\quad + \int_{-S}^S \frac{r}{\sigma_g^2} dx x^2 \exp\left(-\frac{x^2}{2\rho^2\sigma_g^2}\right) \\
&\quad \times \int_{-\infty}^{\infty} \sqrt{2\rho^2 \left(Q - \frac{r^2}{\sigma_g^2}\right)} dy \\
&\quad \times \frac{1}{2\pi\rho^2\sqrt{Q\sigma_g^2 - r^2}} \exp(-y^2) \tag{88}
\end{aligned}$$

$$\begin{aligned}
&= \int_{-S}^S \frac{r}{\sigma_g^2} dx x^2 \exp\left(-\frac{x^2}{2\rho^2\sigma_g^2}\right) \\
&\quad \times \int_{-\infty}^{\infty} dy \frac{1}{\pi\sqrt{2\rho^2\sigma_g^2}} \exp(-y^2) \\
&\quad \left(\because \int_{-S}^S dx x \exp\left(-\frac{x^2}{2\rho^2\sigma_g^2}\right) = 0\right) \\
&= \frac{2r}{\sigma_g^2\sqrt{2\pi\rho^2\sigma_g^2}} \int_0^S dx x^2 \exp\left(-\frac{x^2}{2\rho^2\sigma_g^2}\right) \\
&\quad \left(\because \int_{-\infty}^{\infty} dy \exp(-y^2) = \sqrt{\pi}\right) \\
&= \frac{2r}{\sigma_g^2\sqrt{2\pi\rho^2\sigma_g^2}} \left( \left[ -\rho^2\sigma_g^2 x \exp\left(-\frac{x^2}{2\rho^2\sigma_g^2}\right) \right]_0^S \right. \\
&\quad \left. - \int_0^S dx (-\rho^2\sigma_g^2) \exp\left(-\frac{x^2}{2\rho^2\sigma_g^2}\right) \right),
\end{aligned}$$

where we used integration by parts

$$\begin{aligned}
&= \frac{2r}{\sigma_g^2\sqrt{2\pi\rho^2\sigma_g^2}} \left( -\rho^2 S \sigma_g^2 \exp\left(-\frac{S^2}{2\rho^2\sigma_g^2}\right) \right. \\
&\quad \left. + \rho^2\sigma_g^2 \int_0^{\frac{S}{\sqrt{2\rho^2\sigma_g^2}}} \sqrt{2\rho^2\sigma_g^2} dx' \exp(-x'^2) \right), \\
&\quad \text{where } x' = \frac{x}{\sqrt{2\rho^2\sigma_g^2}} \\
&= -rS\rho\sqrt{\frac{2}{\pi\sigma_g^2}} \exp\left(-\frac{S^2}{2\rho^2\sigma_g^2}\right) + \rho^2 r \operatorname{erf}\left(\frac{S}{\sqrt{2\rho^2\sigma_g^2}}\right), \tag{89}
\end{aligned}$$

$$\begin{aligned}
C3 &= \int_{-\infty}^{\infty} dy y \int_S dx S \frac{1}{2\pi \sqrt{\left| \rho^2 \begin{pmatrix} \sigma_g^2 & r \\ r & Q \end{pmatrix} \right|}} \\
&\times \exp \left( - \frac{(x \ y) \left( \rho^2 \begin{pmatrix} \sigma_g^2 & r \\ r & Q \end{pmatrix} \right)^{-1} \begin{pmatrix} x \\ y \end{pmatrix}}{2} \right)
\end{aligned} \tag{90}$$

$$\begin{aligned}
&= \int_{-\infty}^{\infty} dy y \int_S dx S \frac{1}{2\pi \rho^2 \sqrt{Q\sigma_g^2 - r^2}} \\
&\times \exp \left( - \frac{\sigma_g^2 y^2 - 2rxy + Qx^2}{2\rho^2 (Q\sigma_g^2 - r^2)} \right)
\end{aligned} \tag{91}$$

$$\begin{aligned}
&= \int_{-\infty}^{\infty} dy y \int_S dx S \frac{1}{2\pi \rho^2 \sqrt{Q\sigma_g^2 - r^2}} \\
&\times \exp \left( - \frac{\sigma_g^2 \left( y - \frac{r}{\sigma_g^2} x \right)^2 + \left( Q - \frac{r^2}{\sigma_g^2} \right) x^2}{2\rho^2 (Q\sigma_g^2 - r^2)} \right)
\end{aligned} \tag{92}$$

$$\begin{aligned}
&= S \int_S dx \exp \left( - \frac{x^2}{2\rho^2 \sigma_g^2} \right) \int_{-\infty}^{\infty} dy y \\
&\times \frac{1}{2\pi \rho^2 \sqrt{Q\sigma_g^2 - r^2}} \exp \left( - \frac{\left( y - \frac{r}{\sigma_g^2} x \right)^2}{2\rho^2 \left( Q - \frac{r^2}{\sigma_g^2} \right)} \right)
\end{aligned} \tag{93}$$

$$\begin{aligned}
&= S \int_S dx \exp \left( - \frac{x^2}{2\rho^2 \sigma_g^2} \right) \int_{-\infty}^{\infty} \sqrt{2\rho^2 \left( Q - \frac{r^2}{\sigma_g^2} \right)} \\
&\times dy' \left( \sqrt{2\rho^2 \left( Q - \frac{r^2}{\sigma_g^2} \right)} y' + \frac{r}{\sigma_g^2} x \right) \\
&\times \frac{1}{2\pi \rho^2 \sqrt{Q\sigma_g^2 - r^2}} \exp(-y'^2),
\end{aligned}$$

$$\text{where } y' = \frac{y - \frac{r}{\sigma_g^2} x}{\sqrt{2\rho^2 \left( Q - \frac{r^2}{\sigma_g^2} \right)}}$$

$$\begin{aligned}
&= S \int_S dx \exp \left( - \frac{x^2}{2\rho^2 \sigma_g^2} \right) \int_{-\infty}^{\infty} 2\rho^2 \left( Q - \frac{r^2}{\sigma_g^2} \right) dy y \\
&\times \frac{1}{2\pi \rho^2 \sqrt{Q\sigma_g^2 - r^2}} \exp(-y^2) \\
&+ S \int_S \frac{r}{\sigma_g^2} dx x \exp \left( - \frac{x^2}{2\rho^2 \sigma_g^2} \right) \\
&\times \int_{-\infty}^{\infty} \sqrt{2\rho^2 \left( Q - \frac{r^2}{\sigma_g^2} \right)} \\
&\times dy \frac{1}{2\pi \rho^2 \sqrt{Q\sigma_g^2 - r^2}} \exp(-y^2)
\end{aligned} \tag{94}$$

$$\begin{aligned}
&= \frac{Sr}{\sigma_g^2} \int_S^\infty dx x \exp\left(-\frac{x^2}{2\rho^2\sigma_g^2}\right) \sqrt{2\rho^2\left(Q - \frac{r^2}{\sigma_g^2}\right)} \\
&\quad \times \frac{1}{2\pi\rho^2\sqrt{Q\sigma_g^2 - r^2}} \sqrt{\pi} \\
&\left(\because \int_{-\infty}^\infty dy y \exp(-y^2) = 0, \int_{-\infty}^\infty dy \exp(-y^2) = \sqrt{\pi}\right) \\
&= \frac{Sr}{\sigma_g^2} \frac{1}{\sqrt{2\pi\rho^2\sigma_g^2}} \left[(-\rho^2\sigma_g^2) \exp\left(-\frac{x^2}{2\rho^2\sigma_g^2}\right)\right]_S^\infty \tag{95}
\end{aligned}$$

$$= \frac{Sr\rho}{\sqrt{2\pi\sigma_g^2}} \exp\left(-\frac{S^2}{2\rho^2\sigma_g^2}\right), \tag{96}$$

$$C1 = \int_{-\infty}^\infty dy y \int_{-\infty}^{-S} dx (-S)p(x, y) = C3,$$

where we used the integration by substitution:

$$x' = -x, \quad y' = -y,$$

$$\therefore \langle f(x)y \rangle = C1 + C2 + C3 = \rho^2 r \operatorname{erf}\left(\frac{S}{\sqrt{2\rho^2\sigma_g^2}}\right). \tag{97}$$

## References

- [1] S. Haykin, *Adaptive Filter Theory*, 4<sup>th</sup> ed., Prentice Hall, Upper Saddle River, NJ, 2002.
- [2] A. H. Sayed, *Fundamentals of Adaptive Filtering*, Wiley, Hoboken, NJ, 2003.
- [3] P. A. Nelson and S. J. Elliott, *Active Control of Sound*, Academic Press, San Diego, CA, 1992.
- [4] S. M. Kuo and D. R. Morgan, *Active Noise Control Systems — Algorithms and DSP Implementations*, Wiley, New York, 1996.
- [5] S. M. Kuo and D. R. Morgan, “Active noise control: a tutorial review,” *Proc. IEEE*, vol. 87, no. 6, pp. 943–973, June 1999.
- [6] Y. Kajikawa, W.-S. Gan, and S. M. Kuo, “Recent advances on active noise control: Open issues and innovative applications,” *APSIPA Trans. Signal Inf. Process.*, vol. 1, e3, Aug. 2012.
- [7] C. R. Fuller and A. H. von Flotow, “Active control of sound and vibration,” *IEEE Contr. Syst. Mag.*, vol. 15, no. 6, Dec. 1995.
- [8] M. M. Sondhi, “The history of echo cancellation,” *IEEE Signal Process. Mag.*, vol. 23, no. 5, Sept. 2006.
- [9] L. Ljung, *System Identification: Theory for the User*, 2<sup>nd</sup> ed., Prentice Hall, Upper Saddle River, NJ, 1999.
- [10] B. Widrow, J. L. Moschner, and J. Kaunitz, “Effects of quantization in adaptive processes. A hybrid adaptive processor,” *Stanford Electron Lab.*, Rep. 6793-1, 1971.
- [11] T. A. C. M. Claasen and W. F. G. Mecklenbräuker, “Comparison of the convergence of two algorithms for adaptive FIR digital filters,” *IEEE Trans. Acoust. Speech, Signal Process.*, vol. 29, no. 3, pp. 670–678, 1981.

- [12] D. L. Duttweiler, "Adaptive filter performance with nonlinearities in the correlation multiplier," *IEEE Trans. Acoust. Speech, Signal Process.*, vol. 30, no. 4, pp. 578–586, 1982.
- [13] A. Aref and M. Lotfizad, "Variable step size modified clipped LMS algorithm," *Proc. 2nd Int. Conf. Knowledge-Based Engineering and Innovation (KBEI)*, pp. 546–550, 2015.
- [14] M. K. Smaoui, Y. B. Jemaa, and M. Jaidane, "How does the clipped LMS outperform the LMS?," *Proc. 19th European Signal Processing Conf. (EUSIPCO)*, pp. 734–738, 2011.
- [15] M. Bekrani and A. W. H. Khong, "Misalignment analysis and insights into the performance of clipped-input LMS with correlated Gaussian data," *Proc. IEEE Int. Conf. Acoustics, Speech, and Signal Processing (ICASSP)*, pp. 5929–5933, 2014.
- [16] L. Deivasigamani, "A fast clipped-data LMS algorithm," *IEEE Trans. Acoust. Speech, Signal Process.*, vol. 30, no. 4, pp. 648–649, 1982.
- [17] M. Bekrani and A. W. H. Khong, "Convergence analysis of clipped input adaptive filters applied to system identification," *Proc. Forty Sixth Asilomar Conf. on Signals, Systems and Computers (ASILOMAR)*, pp. 801–805, 2012.
- [18] B. E. Jun, D. J. Park, and Y. W. Kim, "Convergence analysis of sign-sign LMS algorithm for adaptive filters with correlated Gaussian data," *Proc. IEEE Int. Conf. Acoustics, Speech, and Signal Processing (ICASSP)*, pp. 1380–1383, 1995.
- [19] K. Takahashi and S. Mori, "A new normalized signed regressor LMS algorithm," *Proc. Singapore ICCS/ISITA*, pp. 1181–1185, 1992.
- [20] E. Eweda, "Analysis and design of a signed regressor LMS algorithm for stationary and nonstationary adaptive filtering with correlated Gaussian data," *IEEE Trans. Circuits Syst.*, vol. 37, no. 11, pp. 1367–1374, 1990.
- [21] N. J. Bershad, "On weight update saturation nonlinearities in LMS adaptation," *IEEE Trans. Acoust. Speech, Signal Process.*, vol. 38, no. 4, pp. 623–630, 1990.
- [22] M. H. Costa, J. C. M. Bermudez, and N. J. Bershad, "Statistical analysis of the LMS algorithm with a saturation nonlinearity following the adaptive filter output," *IEEE Trans. Signal Process.*, vol. 49, no. 7, pp. 1370–1387, 2001.
- [23] M. H. Costa, J. C. M. Bermudez, and N. J. Bershad, "Statistical analysis of the FXLMS algorithm with a nonlinearity in the secondary-path," *Proc. 1999 IEEE International Symp. on Circuits and Systems (ISCAS)*, pp. III-166–169, 1999.
- [24] M. H. Costa, J. C. M. Bermudez, and N. J. Bershad, "Statistical analysis of the Filtered-X LMS algorithm in systems with nonlinear secondary path," *IEEE Trans. Signal Process.*, vol. 50, no. 6, pp. 1327–1342, 2002.
- [25] S. D. Snyder and N. Tanaka, "Active control of vibration using a neural network," *IEEE Trans. Neural Netw.*, vol. 6, no. 4, pp. 819–828, 1995.
- [26] M. H. Costa, "Theoretical transient analysis of a hearing aid feedback canceller with a saturation type nonlinearity in the direct path," *Comput. Biol. Med.*, vol. 91, pp. 243–254, 2017.
- [27] M. H. Costa, L. R. Ximenes, and J. C. M. Bermudez, "Statistical analysis of the LMS adaptive algorithm subjected to a symmetric dead-zone-type nonlinearity at the adaptive filter output," *Signal Process.*, vol. 88, pp. 1485–1495, 2008.
- [28] O. J. Tobias and R. Seara, "On the LMS algorithm with constant and variable leakage factor in a nonlinear environment," *IEEE Trans. Signal Process.*, vol. 54, no. 9, pp. 3448–3458, 2006.
- [29] N. J. Bershad, "On error-saturation nonlinearities in NLMS adaptation," *IEEE Trans. Signal Process.*, vol. 57, no. 10, pp. 4105–4111, 2009.



- [30] H. Hamidi, F. Taringoo, and A. Nasiri, “Analysis of FX-LMS algorithm using a cost function to avoid nonlinearity,” *Proc. 5th Asian Control Conf.*, pp. 1168–1172, 2004.
- [31] A. Stenger and W. Kellermann, “Nonlinear acoustic echo cancellation with fast converging memory-less preprocessor,” *Proc. IEEE Int. Conf. Acoustics, Speech, and Signal Processing (ICASSP)*, pp. 805–808, 2000.
- [32] S. Miyoshi and Y. Kajikawa, “Statistical-mechanical analysis of the FXLMS algorithm with nonwhite reference signals,” *Proc. IEEE Int. Conf. Acoustics, Speech, and Signal Processing (ICASSP)*, pp. 5652–5656, 2013.
- [33] K. Motonaka, T. Koseki, Y. Kajikawa, and S. Miyoshi, “Statistical-mechanical analysis of adaptive Volterra filter with the LMS algorithm,” *IEICE Trans. Fundam. Electron. Commun. Comput. Sci.*, vol. E104-A, no. 12, pp. 1665–1674, Dec. 2021.
- [34] K. Kugiyama and S. Miyoshi, “Statistical-mechanical analysis of adaptive Volterra filter for nonwhite input signals,” *IEICE Trans. Fundam. Electron. Commun. Comput. Sci.*, vol. E107-A, no. 1, pp. 87–95, Jan. 2024.
- [35] H. Nishimori, *Statistical Physics of Spin Glasses and Information Processing: An Introduction*, Oxford University Press, New York, 2001.
- [36] S. Miyoshi and Y. Kajikawa, “Statistical-mechanics approach to the Filtered-X LMS algorithm,” *Electron. Lett.*, vol. 47, no. 17, pp. 997–999, Aug. 2011.
- [37] S. Miyoshi and Y. Kajikawa, “Statistical-mechanics approach to theoretical analysis of the FXLMS algorithm,” *IEICE Trans. Fundam. Electron. Commun. Comput. Sci.*, vol. E101-A, no. 12, pp. 2419–2433, Dec. 2018.
- [38] V. J. Mathews, “Adaptive polynomial filters,” *IEEE Signal Process. Mag.*, vol. 8, no. 3, pp. 10–26, 1991.
- [39] S. Miyoshi, “Statistical-mechanical analysis of adaptive filter with clipping saturation-type nonlinearity,” *IEEE Trans. Signal Process.*, vol. 70, pp. 4867–4882, Oct. 2022. (Open Access)
- [40] A. Chambolle, R. A. DeVore, N. Lee, and B. J. Lucier, “Nonlinear wavelet image processing: variational problems, compression, and noise removal through wavelet shrinkage,” *IEEE Trans. Image Process.*, vol. 7, no. 3, pp. 319–335, March 1998.
- [41] A. Beck and M. Teboulle, “A fast iterative shrinkage-Thresholding algorithm for linear inverse problems,” *SIAM J. Imaging Sciences*, vol. 2, no. 1, pp. 183–202, 2009.
- [42] J. Claerbout and F. Muir, “Robust modeling with erratic data,” *Geophysics*, vol. 38, no. 5, pp. 826–844, 1973.
- [43] E. J. Candès, J. Romberg and T. Tao, “Robust uncertainty principles: exact signal reconstruction from highly incomplete frequency information,” *IEEE Trans. Inf. Theory*, vol. 52, no. 2, pp. 489–509, Feb. 2006.
- [44] D. L. Donoho, “Compressed sensing,” *IEEE Trans. Inf. Theory*, vol. 52, no. 4, pp. 1289–1306, April 2006.
- [45] B. Widrow and M. E. Hoff, Jr., “Adaptive switching circuits,” *IRE WESCON Conv. Rec.*, Pt. 4, pp. 96–104, 1960.
- [46] A. Engel and C. V. Broeck, *Statistical Mechanics of Learning*, Cambridge University Press, Cambridge, 2001.
- [47] O. J. Tobias, J. C. M. Bermudez, and N. J. Bershad, “Mean weight behavior of the Filtered-X LMS algorithm,” *IEEE Trans. Signal Process.*, vol. 48, no. 4, pp. 1061–1075, Apr. 2000.

- [48] O. J. Tobias, J. C. M. Bermudez, R. Seara, and N. Bershad, "An improved model for the second moment behavior of the Filtered-X LMS algorithm," *Proc. IEEE Adaptive Syst. Signal Process., Commun., Contr. Symp.*, Lake Louise, AB, Canada, pp. 337–341, Oct. 2000.