

# Literary and Colloquial Tamil Dialect Identification

M. Nanmalar<sup>1</sup>, P. Vijayalakshmi<sup>1</sup>, and T. Nagarajan<sup>2</sup>

<sup>1</sup>Department of ECE, Sri Sivasubramaniya Nadar College of Engineering, Chennai, India.

<sup>2</sup>Department of CSE, Shiv Nadar University Chennai, India.

## 1 Abstract

Culture and language evolve together. With respect to Tamil, the form of the language that people use nowadays has come a long way from its origins. These days, the old literary form of Tamil is used commonly for writing and the contemporary colloquial Tamil is used for speaking. Human-computer interaction applications require Colloquial Tamil (CT) to make it more accessible and easy for the everyday user and, it requires Literary Tamil (LT) when information is needed in a formal written format. Continuing the use of LT alongside CT in computer aided language learning applications will both preserve LT, and provide ease of use via CT, at the same time. Hence there is a need for the conversion between LT and CT dialects, which demands as a first step, dialect identification. Dialect Identification (DID) of LT and CT is an unexplored area of research. There is a considerable research potential in this area, because, i) LT is standardised while CT is not fully standardised and, ii) they have only subtle differences. Five methods are explored in our work, which originated from the preliminary work using Gaussian Mixture Model (GMM) for dialect identification of LT and CT, which offered a motivation with an identification accuracy of 87%. In the current work, keeping the nuances of both these dialects in mind, one other implicit method - Convolutional Neural Network (CNN); two explicit methods - Parallel Phone Recognition (PPR) and Parallel Large Vocabulary Continuous Speech Recognition (P-LVCSR); two versions of the proposed explicit Unified Phone Recognition method (UPR-1 and UPR-2), are explored. These methods vary based on: the need for annotated data, the size of the unit, the way in which modelling is carried out, and the way in which the final decision is made. Even though the average duration of the test utterances is less - 4.9s for LT and 2.5s for CT - the systems performed well, offering the following identification accuracies: 87.72% (GMM), 93.97% (CNN), 89.24% (PPR), 94.21% (P-LVCSR), 88.57 (UPR-1), 93.53% (UPR-1 with P-LVCSR), 94.55 (UPR-2), and 95.61% (UPR-2 with P-LVCSR).

**Keywords:** *dialect identification, literary and colloquial Tamil, implicit and explicit methods, statistical machine learning, neural network*

## 2 Introduction

Tamil is an ancient language that was chiseled to a state of beauty and perfection. It is used by more than 80 million people around the world. Apart from the state of Tamil Nadu, India, it is one of the official languages of Sri Lanka and Singapore. There is a significant Tamil speaking minority in Malaysia, Myanmar and the United States of America.

With such a vast heritage and linguistic excellence, the language evolved over time, but still retained its identity. The traditional literary form of the language, from here on called Literary Tamil (LT), possessed richness but is currently used only in the written form of the language, in formal circumstances. The current colloquial form of the language, from here on called Colloquial Tamil (CT), is widely used as a way of vocal communication, but is not popular in the written form. Hence, we are left with a need to preserve and develop the old and the new respectively. In order to preserve and teach the richness of the traditional literary form of the language, computers would need to understand and process the literary form. In order to improve human communication with computers, computers would need to understand the colloquial form of the language. This naturally leads us to the task of bridging the old and the new by finding ways to convert LT to CT and vice-versa. To aid conversion, the input form of the language must first be classified. When considering the differences and similarities between LT and CT, they are quite analogous to two dialects. Hence, classifying

Table 1: DID systems developed for Dravidian languages in literature.

|                  | Telugu [35]                                    | Kannada [5]                               | Malayalam [37]   |
|------------------|--|---|--|
| No. of dialects  | 3  | 5   | 2  |
| Features         | Mel Frequency Cepstral Coefficients            | Spectral and Prosodic features            | Spectral and Prosodic features                                     |
| Classifier       | Gaussian Mixture Model and Hidden Markov Model | Support Vector Machine and Neural Network | Artificial Neural Networks, Support Vector Machine and Naive Bayes |
| Database         | New database developed                         | New database developed                    | New database developed   |
| Best performance | 84.5%  | 99.24%                                    | 90.2%  |

them can be considered a dialect identification task.

Although there is no specific definition of what colloquial Tamil should be like (no standard grammar or lexicon), we define it as, ‘that which is acceptable, understandable and neutral to the majority of Tamil speakers’. It is the language that is used by the people from different regions and social backgrounds and hence is popular in, and popularized by, the media [32]. This colloquialism is an inevitable process that every language goes through and hence must be addressed specifically.

Dialect Identification (DID) is an utterance-level variable-length sequence classification task. We aim to extract the maximum information out of a single utterance to make a decision. In one sense, DID is more challenging than spoken Language Identification (LID) because of the lack of much dissimilarity between dialects. It can also be considered a difficult case of language ID, where it is applied to a group of closely related languages that share a common character set [39]. Dialects are mostly similar, in that, there is a reasonable level of mutual intelligibility, but they also vary in some characteristics. We aim to capture minute differences, like attempting to distinguish between identical twins. Since the authors’ native language is Tamil, they were able to learn the nuances of the different dialects of the language.

Existing work on Indian LID has not reached a critical level when compared to western and european languages [1]. While this is true for LID systems built on Indian languages, even though there exists a considerable number of them, the fact is even more relevant for Indian dialects for which not much research interest exists at the moment. This is due to the lack of datasets for Indian dialects. For this reason, there aren’t many DID systems in Indian languages, especially Tamil, to which the current work could be directly compared to. But a comparison can be made with respect to dialect identification in other Indian languages, or LID systems in general. Amongst the Dravidian languages — Tamil, Telugu, Kannada and Malayalam — DID systems for Telugu [35], Kannada [5] and Malayalam [37] have been addressed in literature. The details of these systems are provided in Table 1. The apparent need to address the dialects in Tamil is carried out in the current work considering a commonly spoken dialect in Tamil, namely colloquial Tamil.

LID systems focussed on Indian languages, using various techniques, can be found in [13, 15, 28, 30, 34]. LID systems in which Tamil is one of the target languages can be found in [13, 15, 16, 19, 28, 30, 34, 36]. When considering all these LID systems in literature, both generative (GMM or Hidden Markov Model (HMM)), and discriminative (Support Vector Machine (SVM) or Neural Network) models are found to be in use. The features used include, Mel Frequency Cepstral Coefficients (MFCC), prosodic features and Linear Predictive Coefficients (LPC). It should be pointed out that in almost all of these cases [13, 15, 16, 28, 30, 34], the LID performance of Tamil is highest amongst all the target languages included in the system. Similarly, from zissman’s comparison of four approaches [40], we can see that Tamil is the only language which is not confused with other languages, when tested with both 45 and 10 second utterances.

From these evidences, it could be said of Tamil that it has distinct language cues which helps LID systems identify it accurately. But at the same time, in [13], Tamil is confused with Malayalam and Telugu, which are both Dravidian languages. This seems to point to the fact that identifying Tamil is a tougher task when similar languages are included, and hence there is confusion. It would be fair to say that this confusion is even more so in the case of dialects. However, from the analysis and experiments in the current work, we find that the task of identifying literary and colloquial Tamil dialects is achievable with the help of

conventional and proposed methods.

Further, in [38], it was concluded that when the glottal flow derivative of two speakers were interchanged, the dialects were interchanged as well. This is because significant speaker and dialect specific information such as noise, breathiness or aspiration, and vocalization is carried in the glottal signal. Based on these findings, it is suggested that even though a dialect identification task is usually considered to be closely associated with the language identification task, it may actually be more closely related to the task of speaker identification. Since MFCC is a feature that is commonly used in speaker identification, it offers another justification for the use of MFCC in dialect identification as well. In [27], it is suggested and proven that a significant part of the language is characterised by its vowels. This fact is in line with the proposal in the current work that, the nasal vowel carries one of the main cues that can distinguish between literary and colloquial dialects of Tamil.

The approaches to DID are similar to those used in LID [6]. Existing LID/DID systems can be classified into two major categories, namely Explicit and Implicit LID/DID systems, based on whether the system requires annotated corpora or not [23]. Explicit methods require annotated corpus and hence are not usually preferred if the aim is to identify many dialects or languages. However in the current work, we address only two dialects and thus have the advantage of working on both implicit and explicit systems. In this context, conventional methods have been evaluated, with and without modifications; and new methods have been proposed and evaluated.

Initially, implicit systems are built, because the speech data can be used as such without annotation. In this regard, Gaussian Mixture Models (GMM) and Convolutional Neural Networks (CNN)-based classifiers are built. GMM-based classification [6] is one of the simplest ways to identify dialects and the system offered a reasonable performance. One of the reasons for good performance in this case may be the unique characteristic of CT - nasalized vowels [25]. Use of Gaussian mixture models for dialect/language identification is quite common in literature [13, 15, 27, 28, 30, 36]. In [15, 27, 30], GMM is the main modelling technique with MFCC, vowel information, and prosody being used as the main feature in these three systems respectively. In [28], GMM is compared with GMM-UBM (Universal Background Model), while in [13], it is compared with HMM and Artificial Neural Networks (ANN). In [36], it is combined with phone recognition and SVM. All these methods yield good performance in general, but it is agreed that even though GMM is successfully employed for speaker recognition, its language identification performance has consistently lagged that of phone-based approaches [36].

Generally, DID/LID does not perform well if the data is noisy. The speech corpus used in the current work is collected from scratch. Part of it is purposefully recorded in a mildly noisy environment, to evaluate whether the systems work even in the presence of noise. It is claimed that CNN works well on noisy data [7]. Hence a CNN-based system is developed and evaluated. Here, one dimensional(1D)-CNN is utilized. A major motivation for using 1D-CNN is that the rhythmic and prosodic characteristic differences of literary and colloquial speech are reflected only across time. We believe that the network learns these patterns by convolving along time. In [4], 1D-CNN is used to learn features from the magnitude spectrum of speech frames in order to classify shouted speech from normal speech. In the current work, we use MFCC features to train the network as in [21]. Whereas, [7] and [24] extract features using CNN, but use other methods such as GMM-ivector and SVM for classification respectively. The manner in which 1D-CNN is adapted to learn from MFCC is detailed in Section 5.2.

The simplest systems require only acoustic data, but in order to build better ones, phonetic transcription is also required [27]. Working on only two dialects offered the motivation to develop some explicit systems as well. In this regard, the annotated corpus, that is required for explicit systems, is built. This task is particularly difficult in the case of CT. The reasons for which will be discussed in Section 4. The results are analysed and compared. The following approaches and its variants are evaluated: Parallel Phone Recognition (PPR), Parallel-Large Vocabulary Continuous Speech Recognition (P-LVCSR), and Unified Phone Recognition (UPR).

Among the various approaches, phone-recognition approach offers considerable promise, as it incorporates sufficient knowledge of the phonology of the dialects to be identified [29]. Considering the conventional explicit systems, Phone Recognition Followed by Language Modeling (PRLM) and Parallel PRLM methods are quite popular and are recommended when the transcribed data is limited. On the other hand, if a good amount of transcribed data is available for each dialect, Parallel Phone Recognition (PPR) can be utilized [6]. More use of PPR can be found in [30] and [16]. In [23] and [11], parallel recognition method, but with syllable-like and variable length subword units, instead of phones, are used. In [16], a set of large phone-based ergodic HMMs are trained for each language and the language is identified as that associated with the

model set having the highest acoustic likelihood. Here too, Tamil obtained the highest score. The issues in PPR for LID are studied in [30]. In the current work, three different variations of PPR are built, and their performances evaluated.

So far, implicit systems with no memory (or temporal relationships) and explicit systems with memory, but smaller units (phone) of knowledge, were addressed. Application of higher knowledge sources to improve the performance of DID follows. Full sentence recognition leads to better performance than the same system using recognition of phonemes alone [9]. A comparison of LID systems based on phone level and word level outputs with and without language model can be found in [33]. Here, it was demonstrated that the word-based system with trigram modelling of words offered superior performance than a phone-based system. Dragon systems has argued that LVCSR is the best way to extract information from a given speech signal [20]. Even in the current work, this conclusion remained true and this method offered performance better than PPR and other implicit methods.

In addition to the methods above, we propose two methods based on LVCSR named UPR-1 and UPR-2. These methods are inspired from the P-LVCSR method, but the modelling technique and decision making method is different. Unlike P-LVCSR, UPR-1 and UPR-2 use the idea of universal modelling and word-based classification techniques. To improve the performance of UPR-1, UPR-2 evaluates the word outputs again, to refine the decision. These systems offer performance on par with the P-LVCSR system.

The organisation of the paper is as follows. The nuances of literary and colloquial Tamil are detailed in Section 3. The details of the corpus, both text and speech, are provided in Section 4. The six methods are split into three categories. The first two methods, GMM and CNN, which are implicit methods, are detailed in Section 5. The two explicit systems based on parallel recognition are detailed in Section 6. The two proposed systems based on unified phone modelling are detailed in Section 7. The results are discussed in Section 8.

### 3 Nuances of Literary and Colloquial Tamil

A standard language can be thought of as possessing the following functions, as per [8]. They are,

- The unifying function, which gives it the ability to unite multiple dialect communities into a single one that corresponds to the standard language.
- The separating function, which distinctly separates it from other standard languages.
- The prestige function, which gives the prestige of using the standard language.
- The frame of reference function, which gives it the ability to objectively define correctness of the language.

Literary Tamil used in the current work satisfies all the functions of a standard language mentioned above. Over time, the literary form of Tamil eventually became archaic. Due to the presence of an implicit need in the society for a language that eases communication effort and is acceptable by all, the standard language evolved to produce colloquial Tamil. Some of the features of colloquial Tamil include the fact that it does not contain features pertaining to caste, religion, or region. All members of the community that can be identified with the standard form of language, irrespective of the dialect (whether Madurai Tamil, Kongu Tamil, Tirunelveli Tamil, Brahmin Tamil, etc.), understand and, most of the time, speak the colloquial version of Tamil.

Due to urbanization and intellectualization, literary Tamil has taken new forms, such as hyperlect (which is the Tamil used by the elite) or edulect (which is the Tamil used by the educated), which can be thought of as subclasses of colloquial Tamil. Irrespective of these recent developments, the status of classical literary Tamil has not been reached by the colloquial version. But, the problem lies in the fact that, even though LT has a prestigious status, after a certain point of time it was not used for oral communication. For informal oral communication, CT is used.

Colloquial Tamil does not possess a standard orthographic transcription or grammar. In [10], it is stated that “In the strictest sense, no spoken language can ever be fully standardized.” He goes on to say that writing and spelling are easily standardized, but the standardization of the spoken form of a language is an “ideology” - an idea, not a reality. With an absence of fully defined standards in colloquial Tamil, [12] talks about a restandardization that can be expected in the future, since the language possesses flexible stability. That is, a new version of the language with its own spoken form, that challenges and attempts to capture some of the domains of the older, can be expected. In [31], Shiffman points out that colloquial Tamil, which

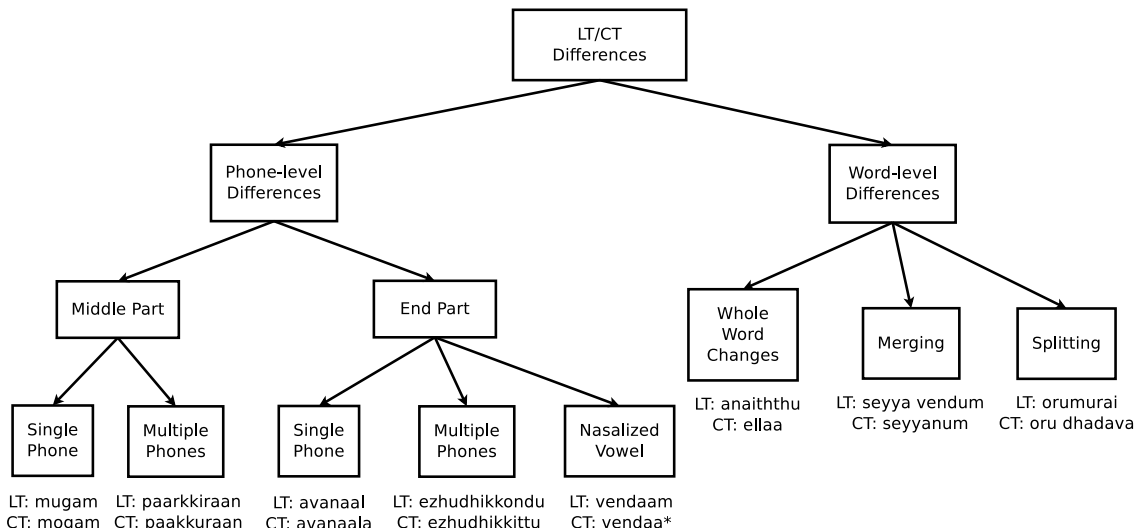

Figure 1: Differences between literary and colloquial Tamil

he calls spoken Tamil, has some set of standards. In the current work, we assume the same. The assumption is that there is an implicit standard for colloquial Tamil which is understood and accepted by most of Tamil speakers.

It must be noted that, there are a lot of similarities between literary and colloquial Tamil, but the distinguishing factors, or the differences, are comparatively less. Less because, the differences occur mostly at the subword level where a phoneme or a small phoneme sequence differs. Apart from this, there are also some cases when the whole word is different. At the phoneme level, the change can be observed with one or more phonemes. Usually this can be observed for the phonemes at the middle and/or towards the end. At the word level, the whole word differs. To clarify, the difference between the former and the latter can be explained in terms of a total lack of correlation between the phonemes of the equivalent literary and colloquial word. The differences at the word level can also occur across a pair of words. Here, the two words of one form (LT or CT) appear merged into one, in the other form; or a single word splits into two.

One unique feature in colloquial Tamil is the acoustic property called nasalization. Nasalization is the process in which a pair of phonemes in a word containing a vowel followed by a nasal consonant, is replaced by the nasalized version of the vowel alone. The end consonant is removed and the vowel is called a nasalized vowel. In classifying literary and colloquial Tamil, nasalization is a distinctive cue. Colloquial version of Tamil trades ‘ease of speech’ for ‘beauty and sophistication’. Two examples follow. The phoneme (/zh/) in Tamil, adds beauty and sophistication to literary Tamil. But it is replaced with its close sounding relative phones: (/l/) or (/lx/) for the sake of ease [14]. Another example is that of the two phones (/r/) and (/rx/) are considered seriously as possessing a difference, but the difference is simply ignored in most colloquial speech. From the above discussion we find that a lot of differences pertain to acoustic differences in general, and phone level differences. It leads to the conclusion that techniques that focus on these features work better. More details about the similarities and differences between literary and colloquial Tamil are provided in Figure 1.

## 4 Corpus

The corpus used in the current work is created from scratch due to the unique nature of the requirements. Both text and speech data in the corpus are collected, recorded, and annotated, for the current task.

### 4.1 Text Corpus

The first source of both literary and colloquial Tamil text data was the internet. Collecting literary Tamil text was simple. Since literary Tamil has a standard grammar and orthographic structure, it is well used in written form all over the internet in abundance. On the contrary, colloquial Tamil’s lenient standards make it difficult to have a standard written form. For a long time, until a few decades ago, there was no colloquial Tamil in literature. The earliest works using colloquial Tamil include genres like novels and short

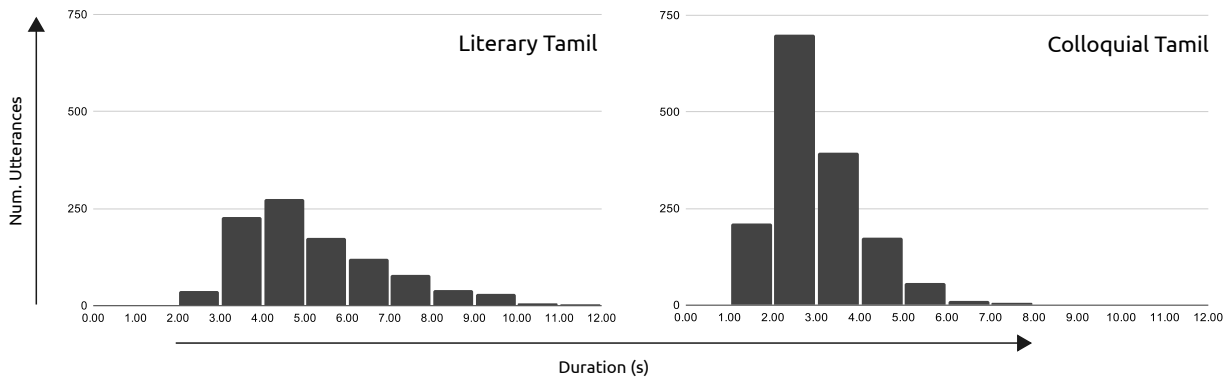

Figure 2: Histogram of LT and CT Utterance Sizes

stories. Many writers focussed on reformation of the society took to such language to depict the real life of people [31]. But there are some major problems. First is the lack of consistency of language across writings from different authors. Each one followed their own style and they also followed their own interpretation of colloquial Tamil. Second, is code switching, by which, the authors drifted from one dialect to another. Some writers may write purely in colloquial Tamil, while others may mix it partly with literary Tamil, still others may use region/religion-based dialects in between. Due to the factors mentioned above, text data for colloquial Tamil is comparatively very much limited and non-standardized on the internet. For the same reasons, colloquial Tamil data collection and correction proved to be very difficult in the current work. A lot of work was required in shaping the data into a standard form. It must be noted that this is not a parallel corpus, since manually collecting and correcting a parallel corpus is a tedious and time consuming process which seemed to take away the focus of the current work. It will be pursued in the future.

## 4.2 Speech Corpus

Speech data is collected from volunteers who work inside the institute of the authors. These volunteers are able to read and speak both literary and colloquial Tamil text. Totally, 79 volunteers contributed to this corpus. The speech data is collected from different age groups. These include bachelor and graduate students, research scholars and faculties of various ages. The audio is recorded using two different microphones in parallel - a condenser and a dynamic microphone. The reason for this is that the two have different frequency and gain characteristics. The condenser microphone is sensitive and tends to pick up more from the environment. The dynamic microphone is less sensitive to low gain and high frequency and usually has a better signal to noise ratio when compared to the condenser microphone, for the same environment. The recording environment is a computer laboratory which is not sound proofed. The noise levels are usually quite less, but with an air conditioning unit or a ceiling fan switched on, the noise levels can be higher. With an aim to record the speech in both noiseless and noisy environments, to reflect real life data and for better generalization, these appliances are switched on and off as needed for different sets of data.

Some pre-processing steps are performed on these recordings. For the sake of the comfort of the volunteers, the recording of each sentence in the corpus is not time limited. This leads to the presence of leading and trailing silences which need to be trimmed. Hence, silence trimming is the first step. According to [20], trimming silence is one of the simplest ways to obtain better results. The next step is the preparation of the annotated corpus using phonetic transcriptions and HMM-based viterbi alignment. The corpus is then separated into train and test sets that comprise approximately 70 and 30 percent of the total duration respectively. During this separation, it is ensured that no speaker in the training set is present in the testing set. Details of the corpus are provided in Table 2 and Table 3. In all, 4387 LT and 5214 CT utterances were recorded. Duration of the utterances in the test set plays a big role in the results obtained [6] [22]. It measures the efficiency of the dialect identification system. It is a measure of how well the system performs with minimal evidence. Duration of all the test utterances in the corpus is plotted as a histogram in Figure 2. The mean and variance of the duration of LT test utterances is 4.94(s) and 5.04(s) respectively and, for CT, it is 2.50(s) and 1.02(s) respectively.

Table 2: Details of the Speech Corpus - Male and Female speakers in Train and Test set

|                              | LT    |      | CT    |      |
|------------------------------|-------|------|-------|------|
|                              | Train | Test | Train | Test |
| Total no. of Male Speakers   | 21    | 3    | 20    | 6    |
| Total no. of Female Speakers | 43    | 12   | 37    | 15   |

Table 3: Details of the corpus. Duration of Train and Test utterances.

|       |                 | LT    | CT    |
|-------|-----------------|-------|-------|
| Train | Num. Hours      | 04:18 | 03:55 |
|       | Num. Utterances | 3371  | 3649  |
| Test  | Num. Hours      | 01:23 | 01:51 |
|       | Num. Utterances | 1016  | 1565  |

## 5 Implicit Systems

### 5.1 Dialect Identification using GMM

A quick and effortless first level experiment to verify the validity of the work was required since identification of colloquial Tamil is quite an unexplored area of research. The experiment need not require annotations and must validate the assumption that literary and colloquial Tamil can be considered two dialects. This preliminary work was required, because of the high similarities between LT and CT as discussed in Section 3. The ability of dialect identification systems to capture these fine differences, similar to a human being, was in question. Implementing this preliminary system based on GMM with positive results proved the proposed theory and enabled further work.

The Gaussian mixture models were built using 39 dimensional MFCC features. The probability of a training feature vector  $x_d$ , belonging to a particular dialect (either literary or colloquial Tamil), being generated by a Gaussian mixture model that corresponds to the same dialect, can be given by,

$$p(x_d | \lambda_d) = \sum_{i=1}^M w_i g(x_d | \mu_i, \Sigma_i), \quad (1)$$

where  $\lambda_d$  is the model, which comprises the following for each mixture component,

- mixture weights  $w_i$
- the means  $\mu_i$
- the covariance  $\Sigma_i$

The likelihood of a test utterance  $X$  of duration  $T$  is given by,

$$L(X | \lambda_d) = \sum_{t=1}^T \log p(x_t | \lambda_d), \quad (2)$$

where  $x_t$  denotes the feature frames of the utterance at time instants  $t$  and,  $d$  is the dialect which can take two values  $lt$  and  $ct$ .

The maximum likelihood classifier's hypothesis of the dialect is given by,

$$\hat{d} = \arg \max_{d=lt,ct} L(X | \lambda_d) \quad (3)$$

The number of mixtures were varied and the performance was evaluated. A correctness measure of 87.72% was obtained for 128 mixture components. The conclusion of this experiment was that, even with many similarities, the dialects have enough differences (like nasalized vowels) to be classified with the help of just the acoustic features [25].

## 5.2 Dialect Identification using CNN

A one dimensional convolutional neural network (1D-CNN) is developed. The convolutional neural network is not used to learn the features, but rather learn the patterns in the input features that are provided. The input feature is a 39 dimensional MFCC feature (13 Static + 13 Delta + 13 Acceleration). The number of timesteps/frames is to be kept constant in a CNN, hence a fixed number is to be calculated. This is carried out by computing the mean number of MFCC frames across all the utterances in the corpus, and then adding a small constant value to it. For the dataset in the current work, this is determined to be 440 frames, or 4.40s. When the number of frames in a particular utterance is lesser than this constant, zero padding is done, and when the size is more, the frames are truncated. This way, a fixed number of timesteps for each utterance is ensured. The constant is added to find the best trade-off between truncation and zero-padding. For each sample, a categorical label that tells the network whether the input sample belongs to LT/CT, is also provided for training the network.

The use of 1D-CNN for this task is explained below. Whether a CNN is 1D or 2D depends on whether the convolution operation is performed across one or two dimensions. In the current work, that dimension is only across time. The 39 dimensions of the MFCC are assumed to be the channels of the signal. Hence, the dot product that produces each value in the feature map is two dimensional. It can be given by,

$$y_i^l = f(x^l * K_i^l + b_i^l) \quad (4)$$

Where  $x$  is the input,  $K$  is the kernel,  $b$  is the bias, and  $y$  is the output of the  $i^{th}$  kernel and  $l^{th}$  layer. Here,  $x$  and  $K$  are actually two dimensional, where one of the dimensions is the number of channels. This is very similar to convolving a color image with three channels, with a kernel that also contains a third dimension whose size is equal to the number of channels in the input. For color images, the dot product is three dimensional. Further details of the proposed architecture, can be found in block diagram shown in Figure 3. It shows the size of the input and the intermediate feature maps generated by the 1D-CNN.

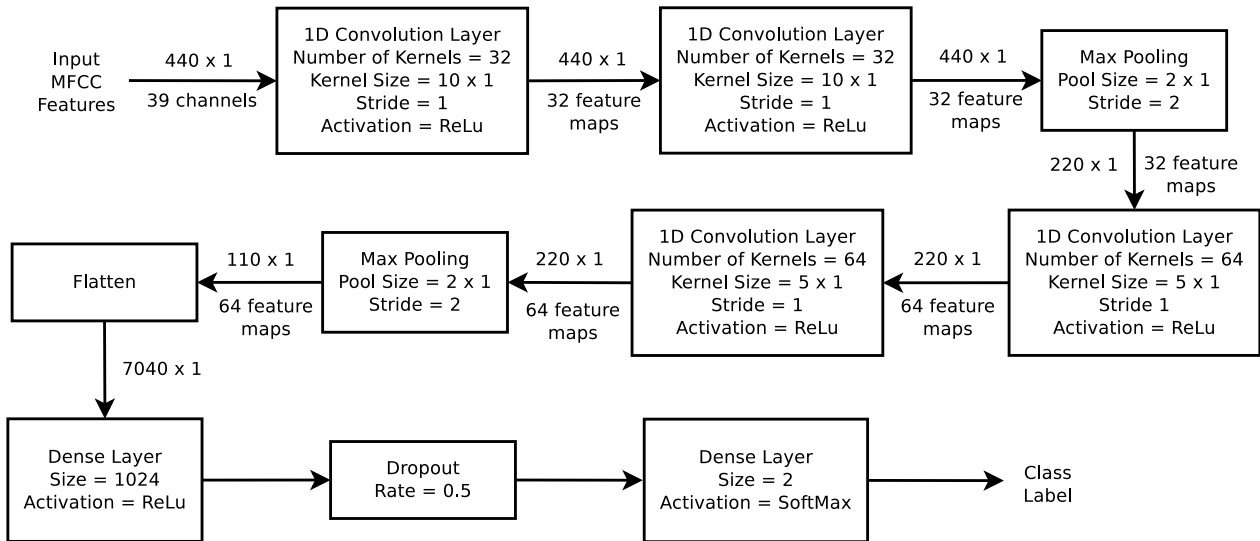

Figure 3: Block Diagram of the proposed 1D-CNN architecture for LT/CT DID

The network is built using two sets of convolutional layers. Each set contains two convolutional layers (totally four), a max-pooling layer and a dropout layer. The first two convolutional layers are made up of 32 filters with a kernel size of 10. The second set of convolutional layers are made up of 64 filters with a kernel size of 5. A rectified linear unit activation (ReLU) function is used in all the convolutional layers. Zero padding is assumed in all convolutional layers to maintain the size of the input at each layer. The pool size of the 1-dimensional max pooling layer is 2 and the rate of the dropout is 0.25. The output of these convolutional layers are fed to two fully connected dense layers, the last of which provides the output. The first dense layer consists of 1024 outputs and is activated by ReLU. The second (last) layer consists of the two outputs that we require (LT/CT) and uses softmax activation. Using this setup an identification accuracy of 93.97% is obtained.



## 6 Explicit Systems

Implicit systems mentioned so far learn from the speech directly without having the need to possess sequential information or linguistic knowledge. On the other hand, explicit systems use linguistic knowledge to build classifiers or identifiers. The phone recognizer present in all the methods that follow (PPR, P-LVCSR, UPR-1 and UPR-2) utilizes 39-dimensional MFCC features (13 static + 13 delta + 13 acceleration) which worked quite well in the preliminary GMM experiments. Cepstral mean subtraction was performed on the features to average out the environmental differences in the recorded speech data.

### 6.1 Dialect Identification using PPR

A parallel phone recognizer integrates the concept of phonology. The PPR models all the phonemes and builds a phone level language model for each dialect, using bigram statistics obtained from the transcription in the dataset. This differentiates it from PRLM where phone recognizer output is used to build the language model.

Two parallel recognizers are built - one for each dialect. For each dialect  $d$ , there exists  $N$  models  $(\lambda_{d1}, \lambda_{d2}, \dots, \lambda_{dN})$ , that correspond to each of the phonemes. Here, each phone model is built with three states and the number of mixture components for the models is chosen based on the number of examples of each phone. The set of models that correspond to all of the phonemes in a particular dialect is denoted as  $\lambda_{dn}$ . This differentiates it from the single model derived for the whole dialect, which is  $\lambda_d$  mentioned in the previous section. It must be noted that the value of  $N$  varies for each dialect, based on the number of phonemes present in the dialect.

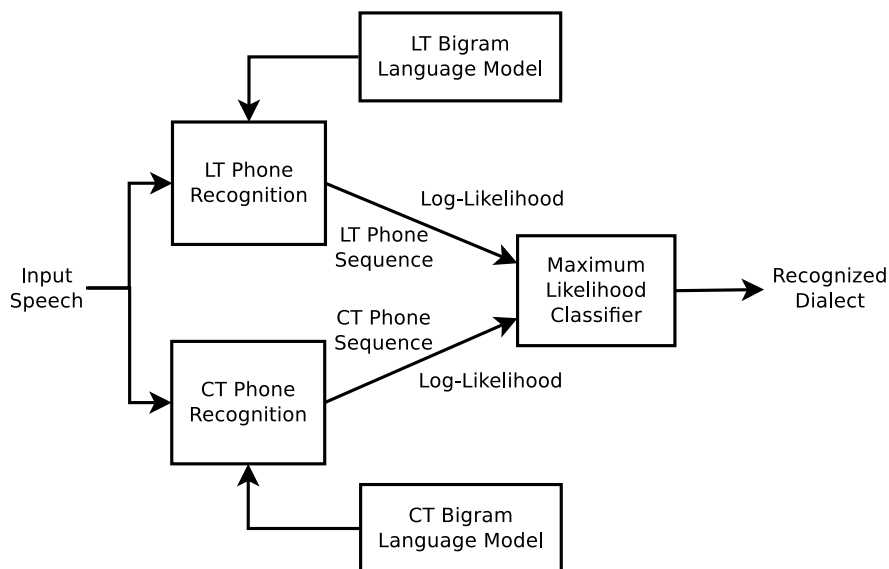

Figure 4: Block Diagram of a PPR System

For each test utterance, both recognizers are used to produce a phone sequence and its corresponding likelihood. The dialect  $\hat{d}$  is predicted using Viterbi decoding to decode the sequence of phonemes, by computing the log-likelihood score corresponding to the best path through the recognizer that belongs to each dialect,

$$\hat{d} = \arg \max_{d=lt,ct} L(\hat{p}_d | \lambda_{dn}), \quad (5)$$

where  $L(\hat{p}_d | \lambda_{dn})$  denotes the log likelihood of the viterbi path  $\hat{p}_d$  for dialect  $d$ . The accumulated likelihood scores are then used to identify the dialect. This process is illustrated in the block diagram shown in Figure 4. PPR is good at language identification since, when it comes to languages, there are considerable differences in the acoustic realization of the same phones. In addition to this, they also possess unique phones that differentiate it even further. However in the current scenario, the two dialects in focus have many (almost all) common phones. To explain further, LT has a total of 39 phones and CT has 40 phones. The 39 phones in LT are common to both LT and CT. The one unique phone in CT is a by-product of code switching of

CT to English. With this kind of a setup, the authors were skeptical about the application of PPR for the current work. But it still worked and yielded good performance. The reasons maybe the following,

- Word endings: Colloquial Tamil words mostly end in a vowel, when compared to LT, where only a few words contain this feature. It can be hypothesized that the vowels in these two dialects are modelled differently because of this factor. Vowels being an important distinguishing factor, could play a major role in classification.
- Effort in Speaking: There is a difference in the effort used by people to speak LT and CT. Native Tamil speakers speak CT effortlessly, while LT is spoken more rigidly. This creates the following differences:
  - Duration: There is a slight difference in the duration of similar sentences spoken in LT and CT. CT sentences tend to be slightly shorter.
  - Vowel Duration: The duration of the vowels specifically is reduced in CT.
  - Stress: LT being a formal language, requires the speakers to stress certain phones the way it is meant to be. CT maintains its casual approach and aims at efficiency than beauty. This aspect is explained with examples in Section 3.
  - Rhythm: One of the beauties of LT is its tendency to be rhythmic. CT does not have this feature and tends to be more spontaneous and free flowing.

These reasons help us understand why PPR worked, and why phone-based ideas in general will work.

### 6.1.1 Version 1 - Conventional PPR

A conventional PPR system, that contains both phone recognition and language modelling, was built. A language model that contains both unigram and bigram statistics of the phones is used. The identification efficiency/performance of this method is 85.24%. Considering the best scores of each method mentioned in the current work, GMM obtained the least score. Even though the score obtained with the first version of this system is the least amongst the PPR-based systems and is also lower than the score obtained using GMM; performance better than GMM can be obtained using slight modifications to this system, as can be seen in the sections that follow.

### 6.1.2 Version 2 - Unique Phone Inclusion

The reason for the slightly lesser performance of PPR - Version 1 is the lack of unique phones. Almost all the phones between LT and CT are similar. This problem can be addressed by highlighting/specifying some unique characteristics in the phones. As discussed in Section 3, CT has a unique characteristic in vowel sounds, called nasalization. Hypothetically, if the effect of nasalization can be understood and incorporated in the system, results could be boosted. In [2], it is concluded that specifying dialect unique sounds will allow the DID to classify both dialects accurately. Hence, in this version, the occurrences of nasalized vowels were located. This was carried out using the characteristics of nasalized vowels detailed in Section 3. Irrespective of the individual vowel, all nasalized vowels which come under this category were identified, grouped together and modelled. This unique model from CT provided an increase in performance as expected, with an identification score of 88.60%.

### 6.1.3 Version 3 - Language Model Exclusion

The conventional PPR system mentioned in Section 6.1.1, integrates the scores from acoustic modelling and language modelling to compute the final score. This is called acoustic-phonotactic decoding or simply, joint decoding [40]. This is done because the inclusion of language/dialect specific knowledge will make the system a better identifier. But here, in our case, the problem is the presence of similar phonemes and partly similar syntax between the two dialects. This factor introduces overlap in the corresponding language models which lead to lower performance. In this version, the decision is made using the scores from the acoustic models alone. As mentioned in Section 3, even though we have similar phone sets for both dialects, there are a lot of unique parameters which work implicitly and contribute to the DID process. This approach provided a further raise in performance, with an identification score of 89.24%, because acoustic data is the major source of information in speech.

## 6.2 Dialect Identification using P-LVCSR

Phonemes are smaller units and most of the differences at the phoneme level were exploited so far. To increase the performance further, higher level units like words and word sequences can be used to improve the identification results. These higher level units provide more evidence. In [3], the authors claim that when we deal with local dialects, working with isolated words is better than working with phone models. However in the current work, we identify the dialect from continuous speech. In this experiment, along with the advantages of phoneme modelling, the advantages of using a word-based lexicon is also utilized. P-LVCSR is similar to PPR, but the likelihood is conditioned by both the phone model and the list of possible words ( $W$ ) in the dialect.

$$\hat{d} = \arg \max_{d=lt,ct} \sum_{t=1}^T L(\hat{p}_d | \lambda_{dn}, W) \quad (6)$$

As mentioned in [6], word could be chosen as the unit of DID, which in turn can be divided into strings, in our case phonemes. In this scenario, the phone models capture all the fine details, while the word lexicon helps the system to obtain the larger picture by providing the sequence of phones in that word. If some of the phones in a particular word is recognized wrongly, the word-based lexicon helps the system to identify the right word despite the errors. The block diagram in Figure 5 represents the architecture of this method.

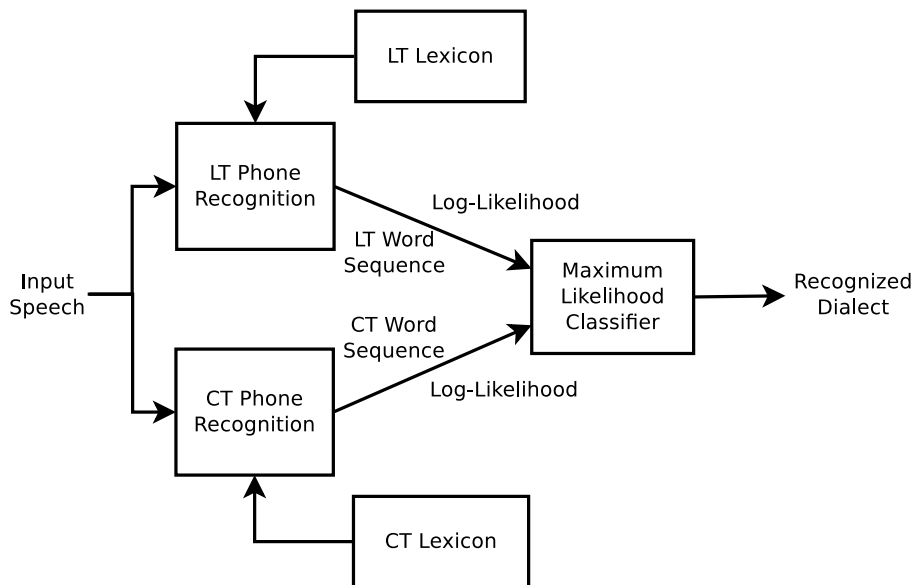

Figure 5: Block Diagram of a P-LVCSR System

In Figure 5, the phoneme recognizer is built using triphone models. During model creation, similar triphones were tied together and then mixture splitting was performed for 4, 8, 12 and 16 mixtures. Best results were obtained for 16 mixtures. This model configuration is maintained in the subsequent methods that follow (UPR-1 and UPR-2). The total number of triphones created from context independent phones are 3488 for LT and 3995 for CT. Lexicons are created for both dialects. LT lexicon contains 4879 entries whereas CT contains 4355.

From Figure 5, we can see that if an unknown test utterance is given, it is processed by both phone recognizers in parallel and, using the lexicon, a word sequence along with its accumulated likelihood is generated by each of the recognizers. The sequence which has the maximum likelihood is chosen as the output sequence. A point to be mentioned here from [18] is the claim that this method is a success because it works even in domains in which the recognition task, of acquiring accurate transcriptions, is too difficult. Similarly, the recognizers in the current work do not have commendable performance. They provide meaningless word sequences even if it is from the recognizer belonging to the right dialect. Still, P-LVCSR is a successful method for the current task because it focuses on finding the difference between the dialects rather than focusing on recognizing the words [9] [20] [18] [33]. It must be mentioned here that language models were not included in this method. The reason being that the amount of useful data for CT is limited, which the

authors aim to resolve in the future. The identification accuracy of this method is 94.21%, which is higher than PPR, GMM and CNN.

## 7 Proposed Explicit Systems - UPR

### 7.1 Motivation

All the methods mentioned above were originally developed to address the LID problem, but they can be adopted to the DID problem as well due to many similarities between both. Our experiments also prove that these methods work well for the case of literary and colloquial Tamil. But since we have knowledge of the dialects in focus, rather than adopting only generalized solutions, more fine tuned approaches can also be utilized. In PPR and P-LVCSR methods, models and lexicons are built separately for LT and CT. If a test utterance is provided to the system, the LT models and/or lexicon and the CT models and/or lexicon compete to provide two different phone/word sequences as outputs, with their corresponding likelihoods. Based on these outputs the corresponding dialect is identified.

The UPR method arises out of the intuition of having a unified system with a unified set of models and unified output. While the previous methods focused on the differences between LT and CT, the proposed method focuses on the commonness. To provide an analogy: the acoustic characteristics of literary and colloquial Tamil can be likened to two versions of the same car released at different time periods. Although they would differ in a few ways, namely in new features being added to, and some old features being removed from, the new version of the car; it would still essentially be the same car. Focusing such similarity/commonness between literary (old) and colloquial (new) Tamil into account, a unified phone recognition makes sense. For example, considering the phoneme /a/: both literary and colloquial Tamil have their own acoustic characteristic since it plays a different role in the corresponding dialects. Despite these differences, we can find considerable commonality between them and model them together. In the same way, the lexicon is also combined. That is, LT and CT words are put together to create a single unified dictionary.

A major advantage of using such a unified system is that, when the data consists of utterances that have both LT and CT words together, instead of having exclusively LT or CT words, they can be modelled as such and considerable performance can be achieved even in this scenario. Although it is simple to collect LT text data from the web, as mentioned in Section 4.1, it is not always possible to collect ‘pure’ LT text data. This is due to the influence of colloquial Tamil in these modern day sources which are deemed to be written in literary Tamil. Similarly, and sometimes more severely, CT text data also has the same problem, as mentioned in Section 4.1. Public data from the internet (facebook, twitter, youtube comments, etc.) and some literature contain mixed data. Obtaining pure LT or CT utterances from these sources through classification and conversion using a natural language processing-based algorithm is not a trivial task. Besides, the algorithm itself will have its own shortcomings and this would be reflected in the processed data. The same is conveyed in [39] where, the authors working on arabic text dialect identification suggest that, even though dialects can be considered as two languages, it is not a trivial matter to automatically distinguish them. In the current work, to prevent such disorderliness in the data, for use in the explicit methods, considerable efforts were taken to pre-process the text manually, before recording the utterances. This is to make sure that each sentence is either pure LT or CT text. When working with a large corpus, proportionally more work would be required. However, the proposed method is a good solution for the issue discussed above. Here, pre-processing mixed text is not required, since the core intuition of the method is unification.

Here, all the 39 phones that are common to both LT and CT are modelled together, while the one unique phone in CT is modelled separately. Together, the unified phone recognition is performed with 40 models. Since this system contains only one recognizer, both the LT and CT lexicons are combined, just like how the phones were modelled together and produces only one output sequence. The dialect is identified from this sequence. The log likelihood of the sequence of words  $W$ , given the unified phone model  $\lambda_u$  and unified word list  $W_u$  is given as,

$$L(W | \lambda_u, W_u) = \sum_{t=1}^T \log p(x_t | \lambda_u, W_u). \quad (7)$$

Unique words between both LT and CT are retained in the unified lexicon. The unified lexicon contains 8907 entries in total. For recognition, both phone models and the lexicon play an equally important

Table 4: Simplified example of UPR output sequences demonstrating three cases of bias.  $W_i$  represents words in the output sequence.

|        | $W_1$ | $W_2$ | $W_3$ | $W_4$ | $W_5$ | Bias              |
|--------|-------|-------|-------|-------|-------|-------------------|
| Case 1 | LT    | LT    | LT    | CT    | LT    | Biased towards LT |
| Case 2 | CT    | LT    | CT    | CT    | LT    | Biased towards CT |
| Case 3 | LT    | CT    | CT    | LT    |       | Equi-probable     |

role. The output produced by the system is usually a meaningless sequence of literary and colloquial Tamil words. The dialect identification is performed based on the bias, which is given by,

$$\hat{d} = \arg \max_{d=lt,ct} count(W_d) \quad (8)$$

where,  $W_d$  is the number of words that belong to each dialect, and the dialect is determined using separate dictionaries/lexicons. A simplified example of this UPR output sequence is provided in Table 4. For an output sequence, if the number of words that belong to CT is more than that of LT, then it is biased towards CT, and hence the sentence will be identified as CT. If the sentence contains an equal number of LT and CT words, then it is considered as an equiprobable case and, is handled separately as a special case. The reason for this scenario could be i) inefficiency or, low performance of the recognition module ii) confusions due to combined lexicon. How this special case is handled, determines whether the system belongs to UPR-1 or UPR-2. The block diagram in Figure 6 explains these methods in detail.

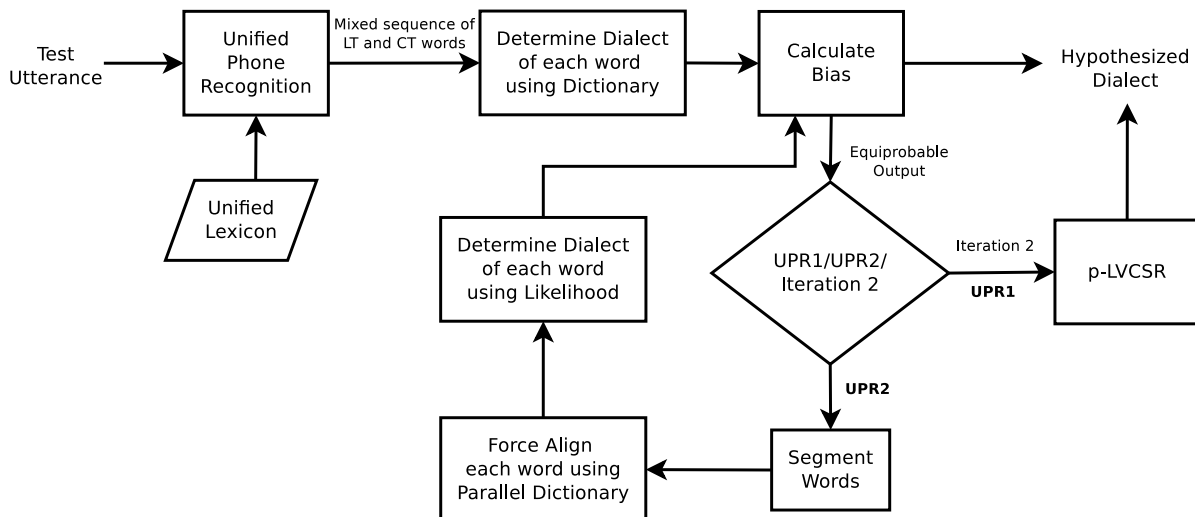

Figure 6: Block Diagram of the proposed UPR system showing both variations

## 7.2 Dialect Identification using UPR-1

In UPR-1, the special equiprobable case, mentioned in Section 7.1, is handled by utilizing the classification outputs of the P-LVCSR. In [17], it was concluded that fusing the results of their own method with that of an existing method provided better results than using just their method in isolation. In the same way, the identification accuracy of UPR-1 in isolation is 88.57%, but together with P-LVCSR the accuracy increases to 93.53%.

## 7.3 Dialect Identification using UPR-2

In UPR-1, a work around is used to solve the equiprobable constraint by using the results from P-LVCSR. But in UPR-2, the issue is addressed directly. The intuition behind this approach is that another round of recognition, i) from a different perspective and ii) with new knowledge, would refine the output. In this way, hopefully, a bias is added, the equilibrium is removed, and the dialect can be identified.

For example, assume a hypothetical equiprobable case where the result hinges on correctly identifying one of the words (say, target word), that was originally incorrectly identified by the unified phone

recognizer. A better decision can be reached if each of the words, including the target word, undergoes a reconfirmation process. Here, the words are segmented and processed using the information from the word label outputs obtained from the unified phone recognizer. The steps of the reconfirmation process is as follows:

1. Find the corresponding parallel word.
2. Phonetically align both the recognized and its parallel word using HMM-based forced Viterbi alignment.
3. The dialect of the word that has the maximum likelihood is chosen.

For each word segment  $x_{wt}$  in the utterance, and its estimated word  $w$ , find the likelihood of the sequence of phones in that word using Viterbi alignment, with respect to the same word and its parallel word in the other dialect. Here  $w_d$  is the word from each dialect.

$$L(w | x_{wt}, w_d) = \sum_{t=1}^T \log p(x_{wt} | \lambda_u, w_d) \quad (9)$$

Dialect of the word is given by,

$$\hat{d} = \arg \max_{d=lt, ct} L(w | x_{wt}, w_d) \quad (10)$$

Doing this, would change the dialect of the target word hence shifting the bias towards the actual dialect of the utterance.

In order to obtain the parallel word, a parallel dictionary is required. One that finds the corresponding CT word for an LT word and vice versa. This dictionary was created using linguistic conversion rules and manual conversion, due to the absence of a parallel corpus. Based on the phonotactic rules available in [32], LT to CT conversion was possible to a certain degree. But the reverse is not a trivial task since there is no established standard, hence CT to LT conversion was carried out manually. Like in all cases, here too, manual conversion is a time consuming process. This is a drawback of this method. Yet, UPR-2 can be made fully automatic if parallel corpus is available. To create one such corpus, considerable research effort is required. The authors are interested in pursuing this in the future. The scope of the current work is to showcase a proof of concept for the proposed method.

In some cases, the output still remains equiprobable. Although this is a very rare scenario, it is solved by using P-LVCSR output as in UPR-1. A block diagram of this process is shown in Figure 6. There is close to a 4% performance difference between the vanilla UPR-1 (88.57%) and UPR-2 (92.29%) methods, without the P-LVCSR step. It must be noted that, in this scenario, an equiprobable case is considered a negative result.

The following experiments were carried out on the basic unified phone recognition system - without P-LVCSR, to resolve issues that could further improve its performance.

### 7.3.1 Issue 1 - Same Parallel Word

In this case, the parallel word derived from the dictionary is the same as the recognized word. There are two ways to handle this. *Solution 1*: The class of the recognized word is retained as the final class of the word, which is the default method. *Solution 2*: The class of the recognized word is ignored and is not considered for the computation of the bias. The word ‘enna’ which is common in both LT and CT falls under this scenario. Using *Solution 2*, an improvement of about 2% was obtained. From 92.29% for basic UPR-2 to 94.07%.

### 7.3.2 Issue 2 - Alignment Unsuccessful

In some cases the derived parallel word, corresponding to the recognized word, is much longer than the recognized word. Based on the length of the original utterance, it may not be possible to align the derived parallel word with it, and no likelihood value would be obtained. Hence, in this case, the dialect of the recognized word is retained. Example: ‘paattutu’ (CT, recognized) and ‘paartukkondeu’ (LT, derived from parallel dictionary). Here the latter is much longer than the former and hence can cause errors during alignment. Using this solution improved the result from 94.07% to 94.40%.

Table 5: Identification Accuracies of each method

| Identification Accuracy |        |
|-------------------------|--------|
| GMM                     | 87.72% |
| CNN                     | 93.97% |
| PPR                     | 89.24% |
| P-LVCSR                 | 94.21% |
| UPR-1                   | 93.53% |
| UPR-2                   | 95.61% |

Table 6: Confusions in each method

|         | LT as LT | LT as CT | CT as LT | CT as CT |
|---------|----------|----------|----------|----------|
| GMM     | 0.88     | 0.12     | 0.13     | 0.87     |
| CNN     | 0.90     | 0.10     | 0.02     | 0.98     |
| PPR     | 0.89     | 0.11     | 0.11     | 0.89     |
| P-LVCSR | 0.95     | 0.05     | 0.06     | 0.94     |
| UPR-1   | 0.96     | 0.04     | 0.09     | 0.91     |
| UPR-2   | 0.97     | 0.03     | 0.06     | 0.94     |

### 7.3.3 Issue 3 - Inappropriate Parallel Word

In some cases, the parallel word in the dictionary may not be appropriate because of rule-based conversions. In such cases, the only option is to manually identify these problematic words and make the necessary corrections. Example: ‘wiyanddanar’ (LT, recognized) and ‘weyanddanar’ (CT, derived from parallel dictionary). Here, the appropriate CT word is ‘wiyandhaanga’. Making such manual changes improved the result from 94.40% to 94.55%.

After identifying these issues and fixing them, utilizing P-LVCSR offered a final improved result of 95.61% which is a near 1% improvement. This shows that both UPR-1 and UPR-2 are considerably successful in identifying two similar dialects: LT and CT. If more efforts are made towards improving the performance of the LVCSR and building parallel dictionaries, much better identification accuracies can be achieved.

## 8 Results and Discussion

The results of all the methods discussed are consolidated in Table 5. GMM being a preliminary and easy to develop implicit system, was the first method experimented. It offered a good score, but in comparison it is the lowest amongst all methods. Similar to GMM, CNN, although being a recently developed technique, does not require phonetically segmented data. It uses only acoustic features for learning, but the performance is better in comparison. All the four methods that follow require phonetic transcriptions since they model the individual phones. PPR offered the lowest performance amongst the explicit methods. Reason being the subtle differences between the phones of the two dialects. P-LVCSR, which is quite similar to PPR, offered better performance. This is due to i) word outputs in P-LVCSR providing better difference in accumulated likelihoods compared to phone outputs in PPR and, ii) higher level units as outputs in P-LVCSR uses more evidence from the language. Among the two variants of the proposed UPR method, which used a unified modelling scheme for both the dialects, UPR-1 on its own, without the P-LVCSR refinement, offered a performance that was close to GMM and PPR. The basic score of UPR-2 (without P-LVCSR), is much higher than that of UPR-1. It can also be seen that while P-LVCSR offers considerable improvement in performance in the case of UPR-1, it offers negligible performance improvement in the case of UPR-2, which speaks for the basic technique of UPR-2. Most of the methods discussed in the current work offer performances that are quite close to each other. The effects of these differences may not be visible in a real world scenario.

Table 6 shows the confusions in all six techniques. From the table we can infer that, a lot of confusions happen for colloquial Tamil. The reason is that, the average duration of a CT utterance is shorter in comparison [26]. If utterances with similar lengths, or a parallel corpus is available, this factor could be overlooked and a better analysis could be provided. An unique result can be observed for the case of CNN. Here we see that CNN handles CT better than all other methods. This could be because of the fact that CNNs learn the full utterance as a whole, rather than learning it frame by frame or, one phone label after

the other as in the case of GMM and the other methods respectively. This process could have captured the wholesome acoustic characteristics of the dialect. Another probable reason is that while pre-processing the utterances for CNN, the size of the data is kept constant by zero padding or truncating it. Hence removing the bias that the length of the sentence offers, as mentioned earlier in the case of other methods.

## 9 Conclusion

Dialect identification is impactful to both academia and the industry, as it can create a positive impact in the society. Colloquial Tamil and the other dialects of Tamil comprise an interesting area suitable for research exploration. In the current work, the DID of two similar dialects - with only subtle differences - in Tamil (LT and CT), using six different methods, are explored. These include two implicit (GMM and CNN), two explicit (PPR and P-LVCSR) and two proposed explicit systems (UPR-1 and UPR-2). A database of considerable size is collected from participants of different age groups and genders, using different microphones and in different environments. GMM and CNN being implicit methods, were easy to develop and they offer considerable performance. CNN works uniquely well for CT. PPR and P-LVCSR, being explicit systems, required annotation of the speech data. Two recognizers, for LT and CT, were developed for each technique. The performance of PPR is not comparable to the effort it takes to annotate the data, while P-LVCSR offered considerable performance, being a word-based system. The proposed methods, UPR-1 and UPR-2 which focus on the commonality between the dialects, are advantageous when organized data is not available. That is, if the recorded utterances contain multiple dialects (with similar phone-sets) together within the same utterance, UPR methods can be used without compromise. While UPR-1 is a basic method relying on the bias in the utterance, UPR-2 utilizes another level of confirmation using HMM-based forced Viterbi alignment, to identify the dialect. While the popular opinion in literature is that word-based methods offer best results, phone-based methods and methods based on only acoustic information also work well for the current task. When there is a limitation in the availability of a complete lexicon, phone-based systems can be used. When organized data is not available, then UPR methods can be used. If using language information is not desired, to eliminate manual efforts and computational costs, implicit methods can be used. Despite differences in the approach, all methods offered decent performances that are quite close to each other (around 90%).

## References

- [1] B. Aarti, S.K. Koppurapu, Spoken Indian language identification: a review of features and databases. *Sādhanā* 43(4), 1–14 (2018)
- [2] F.S. Alorifi, Automatic identification of Arabic dialects using hidden Markov models. Ph.D. thesis, University of Pittsburgh (2008)
- [3] L.M. Arslan, J.H. Hansen, Language accent classification in American English. *Speech Communication* 18(4), 353–368 (1996)
- [4] S. Baghel, M. Bhattacharjee, S. Prasanna, P. Guha, Shouted and Normal Speech Classification Using 1D CNN, in *International Conference on Pattern Recognition and Machine Intelligence*, pp. 472–480. Springer (2019)
- [5] N.B. Chittaragi, A. Limaye, N. Chandana, B. Annappa, S.G. Koolagudi, Automatic text-independent Kannada dialect identification system, in *Information Systems Design and Intelligent Applications*, pp. 79–87. Springer, Singapore (2019)
- [6] A. Etman, A.L. Beex, Language and dialect identification: A survey, in *2015 SAI Intelligent Systems Conference (IntelliSys)*, pp. 220–231. IEEE (2015)
- [7] S. Ganapathy, K. Han, S. Thomas, M. Omar, M.V. Segbroeck, S.S. Narayanan, Robust language identification using convolutional neural network features, in *Fifteenth Annual Conference of the International Speech Communication Association* (2014)
- [8] P.L. Garvin, The standard language problem: concepts and methods. *Anthropological Linguistics* pp. 28–31 (1959)



- [9] J.L. Hieronymus, S. Kadambe, Spoken language identification using large vocabulary speech recognition, in Fourth International Conference on Spoken Language Processing. ICSLP'96, vol. 3, pp. 1780–1783. IEEE (1996)
- [10] M. James, L. Milroy, Authority in language: Investigating language prescription and standardisation. London: Routledge & Kegan Paul 10 (1985)
- [11] A.S. Jayram, V. Ramasubramanian, T.V. Sreenivas, Language identification using parallel sub-word recognition, in 2003 International Conference on Acoustics, Speech and Signal Processing (ICASSP), vol. 1, pp. 32–35. IEEE (2003)
- [12] J.E. Joseph, Eloquence and power: The rise of language standards and standard languages. Burns & Oates (1987)
- [13] S. Jothilakshmi, V. Ramalingam, S. Palanivel: A hierarchical language identification system for Indian languages. Digital Signal Processing 22(3), 544–553 (2012)
- [14] E. Keane, Prominence in Tamil. Journal of the International Phonetic Association pp. 1–20 (2006)
- [15] S.G. Koolagudi, D. Rastogi, K.S Rao, Identification of language using mel-frequency cepstral coefficients (MFCC). Procedia Engineering 38, 3391–3398 (2012)
- [16] L.F. Lamel, J.L. Gauvain, Language identification using phone-based acoustic likelihoods, in 1994 International Conference on Acoustics, Speech and Signal Processing (ICASSP), vol. 1, pp. 293–296. IEEE (1994)
- [17] H. Lloyd-Thomas, E.S Parris, J.H. Wright, Recurrent substrings and data fusion for language recognition, in Fifth International Conference on Spoken Language Processing (1998)
- [18] S. Lowe, A. Demedts, L. Gillick, M. Mandel, B. Peskin, Language identification via large vocabulary speaker independent continuous speech recognition, in Human Language Technology: Proceedings of a Workshop held at Plainsboro, New Jersey, March 8-11, 1994 (1994)
- [19] P. Matejka, P. Schwarz, J. Cernocký, P. Chytil, Phonotactic language identification using high quality phoneme recognition, in Interspeech, pp. 2237–2240 (2005)
- [20] S. Mendoza, L. Gillick, Y. Ito, S. Lowe, M. Newman, Automatic language identification using large vocabulary continuous speech recognition, in 1996 International Conference on Acoustics, Speech and Signal Processing (ICASSP), vol. 2, pp. 785–788. IEEE (1996)
- [21] A.M. Moselhy, A.A. Abdelnaiem, LPC and MFCC performance evaluation with artificial neural network for spoken language identification. International Journal of Signal Processing, Image Processing and Pattern Recognition 6(3) (2013)
- [22] Y.K. Muthusamy, E. Barnard, R.A Cole, Automatic language identification: A review/tutorial. IEEE Signal Processing Magazine 11(4), 33–41 (1994)
- [23] T. Nagarajan, H.A. Murthy, Language identification using parallel syllable-like unit recognition. in 2004 International Conference on Acoustics, Speech and Signal Processing (ICASSP), vol. 1, pp. 401-404. IEEE (2004)
- [24] M. Najafian, S. Khurana, S. Shan, A. Ali, J. Glass, Exploiting convolutional neural networks for phonotactic based dialect identification, in 2018 International Conference on Acoustics, Speech and Signal Processing (ICASSP), pp. 5174–5178. IEEE (2018)
- [25] M. Nanmalar, P. Vijayalakshmi, T. Nagarajan, Literary and Colloquial Dialect Identification for Tamil using Acoustic Features, in 2019 IEEE Region 10 Conference (TENCON), pp. 1303–1306. IEEE (2019)
- [26] T. Niesler, D. Willett, Language identification and multilingual speech recognition using discriminatively trained acoustic models, in Multilingual Speech and Language Processing (2006)
- [27] F. Pellegrino, R. André-Obrecht, Automatic language identification: an alternative approach to phonetic modelling. Signal Processing 80(7), 1231–1244 (2000)

- [28] S. Potla, B. Vardhan, Spoken language identification using gaussian mixture model-universal background model in indian context. *International Journal of Applied Engineering Research* 13(5), 2694–2700 (2018)
- [29] V. Ramasubramanian, A.S. Jayram, T. Sreenivas, Language identification using parallel phone recognition, in *Workshop on Spoken Language Processing* (2003)
- [30] V.R. Reddy, S. Maity, K.S. Rao, Identification of Indian languages using multi-level spectral and prosodic features. *International Journal of Speech Technology* 16(4), 489–511 (2013)
- [31] H.F. Schiffman, Standardization or restandardization: the case for “standard” spoken tamil. *Language in Society* pp. 359–385 (1998)
- [32] H.F. Schiffman, *A reference grammar of spoken Tamil*. Cambridge University Press, UK (1999)
- [33] T. Schultz, I. Rogina, A. Waibel, LVCSR-based language identification, in *1996 International Conference on Acoustics, Speech and Signal Processing (ICASSP)*, vol. 2, pp. 781–784. IEEE (1996)
- [34] A. Shahina, B. Yegnanarayana, Language identification in noisy environments using throat microphone signals, in *2005 International Conference on Intelligent Sensing and Information Processing, 2005.*, pp. 400–403. IEEE (2005)
- [35] S. Shivaprasad, M. Sadanandam, Identification of regional dialects of telugu language using text independent speech processing models. *International Journal of Speech Technology* 23, 251–258 (2020)
- [36] E. Singer, P.A. Torres-Carrasquillo, T.P. Gleason, W.M. Campbell, D.A. Reynolds, Acoustic, phonetic, and discriminative approaches to automatic language identification, in *Interspeech* (2003)
- [37] A. Sunija, T. Rajisha, K. Riyas, Comparative study of different classifiers for Malayalam dialect recognition system. *Procedia Technology* 24, 1080–1088 (2016)
- [38] L.R. Yanguas, T.F. Quatieri, Implications of glottal source for speaker and dialect identification, in *1999 International Conference on Acoustics, Speech and Signal Processing (ICASSP)*, vol. 2, pp. 813–816. IEEE (1999)
- [39] O.F. Zaidan, C. Callison-Burch, Arabic dialect identification. *Computational Linguistics* 40(1), 171–202 (2014)
- [40] M.A. Zissman, Comparison of four approaches to automatic language identification of telephone speech. *IEEE Transactions on Speech and Audio Processing* 4(1), 31 (1996)