

The Database and Benchmark for Source Speaker Verification Against Voice Conversion

Ze Li^{1,2}, Yuke Lin^{1,2}, Tian Yao³, Hongbin Suo³, Ming Li^{1,2}

¹School of Computer Science, Wuhan University, Wuhan, China ²Suzhou Municipal Key Laboratory of Multimodal Intelligent Systems, Duke Kunshan University, Kunshan, China ³AI Center, OPPO, Beijing, China

ming.li369@dukekunshan.edu.cn

Abstract

Voice conversion systems can transform audio to mimic another speaker’s voice, thereby attacking speaker verification systems. However, ongoing studies on source speaker verification are hindered by limited data availability and methodological constraints. In this paper, we generate a large-scale converted speech database and train a batch of baseline systems based on the MFA-Conformer architecture to promote the source speaker verification task. In addition, we introduce a related task called conversion method recognition. An adapter-based multi-task learning approach is employed to achieve effective conversion method recognition without compromising source speaker verification performance. Additionally, we investigate and effectively address the open-set conversion method recognition problem through the implementation of an open-set nearest neighbor approach. The resource and evaluation codes can be found in here¹.

Index Terms: source speaker verification, voice conversion, anti-spoofing

1. Introduction

Automatic Speaker Verification (ASV) systems aim to verify the identities of speakers from their voice samples. In recent years, ASV has been used in many applications with the advancements in deep neural networks. Deep learning-based ASV systems[1, 2] have demonstrated impressive performance across various scenarios. However, the development of synthetic speech technology poses a significant threat to the security of ASV systems. Advanced voice conversion (VC) techniques can generate realistic fake voices, making deep learning based ASV systems vulnerable to spoofing attacks.

VC technology involves transforming the original speaker’s speech into speech with a new target speaker’s timbre while maintaining the content unchanged. In recent years, scholars and research institutions have organized and conducted the Automatic Speaker Verification Spoofing and Countermeasures Challenges [3, 4, 5, 6] series of competitions and developed various defense strategies [7, 8] to combat VC spoofing attacks. However, these strategies are typically used to distinguish between genuine and spoofed speech and do not consider the functionality of identifying the attacker (source speaker) in the converted speech.

Cai et al.’s research [9] indicates that existing VC techniques are not perfect, and the converted speech still retains some aspects of the source speaker’s speech style. They astutely captured this observation and successfully introduced the

identification of the source speaker by training converted audio with source speaker labels for source speaker verification.

Since the concept of source speaker verification is new, no open-source datasets are available to support this task. In this paper, we construct a large-scale dataset of converted speech by 16 well-performed VC methods, i.e., AGAIN-VC [10], FreeVC [11], MediumVC [12], StyleTTS [13], TriAAN-VC [14], VQMIVC [15], KNN-VC [16], SigVC [17], BNE-PPG-VC [18], DiffVC [19], S2VC [20], YourTTS [21], ControlVC[22], Diff-HierVC[23], LVC-VC[24] and Wav2vec-VC[25]. We train a batch of baseline systems using the MFA-Conformer [26] model with the converted speech dataset.

In addition to the source speaker information, the converted speech also leaves traces of conversion methods. Due to essential differences among different VC methods, we can extract these conversion traces to identify the conversion method and to further process the converted speech. Based on this view, we introduce a related task—conversion method recognition [27]. We employ a multi-task learning approach using an Adapter-based MFA-Conformer model [28] for both source speaker verification and conversion method recognition. Since obtaining training sets for all possible conversion methods is not feasible, we extend the closed-set conversion method recognition task to the open-set conversion method recognition task and employ an open-set nearest neighbor(OSNN)[29] method for evaluation.

We summarize our main contributions as follows:

- We generate and release a large-scale converted speech database with 16 common VC methods and train a batch of baseline systems for source speaker verification.
- We introduce a related task called conversion method recognition and employ a multi-task learning approach to simultaneously tackle the source speaker verification task and the conversion method recognition task.
- For the open-set conversion method recognition, we address it by adopting an open-set nearest neighbor approach.

2. Methods

2.1. Adapter-based Multi-Task Learning

While the objective of source speaker verification and conversion method recognition differs, these tasks are interrelated since the converted speech sample contains both source speaker information and information about the speech conversion method. To achieve dual objectives in a single stroke, we design a multi-task learning approach to concurrently identify the source speaker and the specific method.

In multi-task learning, adapters [30, 31] are a common technique to simultaneously learn multiple related but distinct tasks within a single model. The fundamental idea of adapters is to in-

¹<https://sstc-challenge.github.io/>

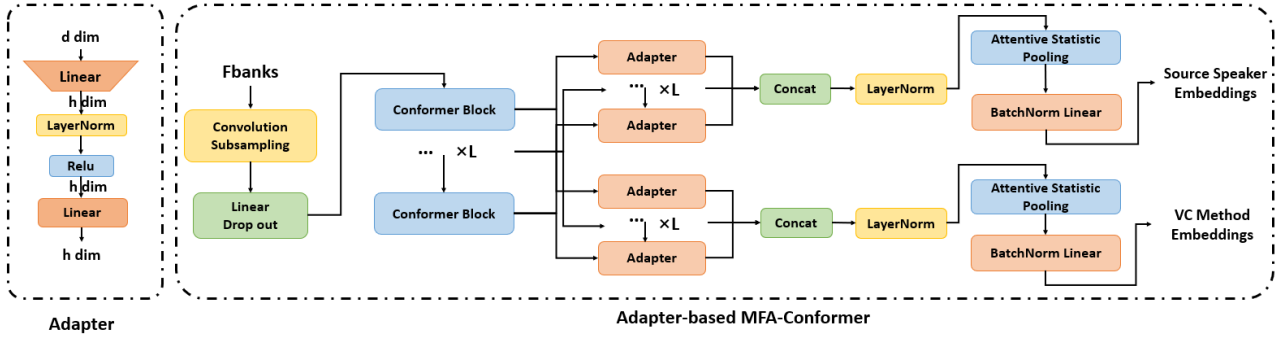

Figure 1: Adapter and Adapter-based MFA-conformer model structure.

introduce tiny, task-specific parameter sets between different layers of the model, allowing parameter sharing across different tasks and facilitating a multi-task learning process with minimum cost.

As shown in Fig 1, we employ the Adapter-based MFA-Conformer model[28] by adding an adapter after each conformer block in the MFA-Conformer architecture.

These adapters fine-tune the outputs from each layer of the conformer model and align them more closely with the target task. In detail, the frame-level output from the i^{th} conformer layer, denoted as $h_i \in R^{d \times T}$, is transformed by the adaptor A_i , and then we concatenate the output feature maps from each adapter and feed them into a LayerNorm layer:

$$h'_i = A_i(h_i), \quad i = 1, 2, \dots, L \quad (1)$$

$$H = \text{Concat}(h'_1, h'_2, \dots, h'_L) \quad (2)$$

2.2. Open-set voice conversion methods recognition

Recognition of VC methods present in the training set is straightforward. However, distinguishing the unseen methods poses a great challenge, given the impossibility of encompassing all VC techniques globally within our training data.

During training, utterances from the same VC method tend to cluster together, while those from different methods are scattered. Therefore, audio samples of VC methods in the training set will be similar to samples from known categories. In contrast, audio samples from unseen methods will not be sufficiently similar to samples from known categories. Furthermore, similarity can be calculated by comparing the Euclidean distances to different categories. Based on this theory, we introduce the open-set nearest neighbor(OSNN)[29] classification method, as shown in Fig 2. The steps of this method are as follows:

- Step 1. Extract all method embeddings $\mathbf{Z} \in R^{N \times d}$ from the training set with the trained method recognition model, and randomly partition them into two subsets at a ratio of 1:9, denoted as TS_1 and TS_9 .
- Step 2. Take the subset TS_9 and calculate the average of embeddings for each method to obtain the class center of each method.
- Step 3. Calculate the Euclidean distance from test sample \mathbf{x} to each class center, and compute the ratio of distances R between its two nearest neighbor centers C_i and C_j . In which, C_i represents the nearest neighbor, and C_j represents

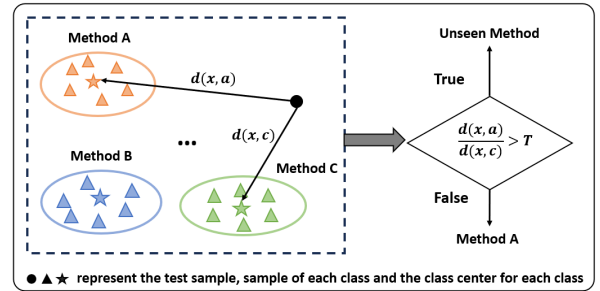

Figure 2: Open-set VC methods recognition based on OSNN method.

the second nearest neighbor:

$$d(\mathbf{x}, \mathbf{y}) = \sqrt{\sum_{i=1}^n (\mathbf{x}_i - \mathbf{y}_i)^2} \quad (3)$$

$$R = d(\mathbf{x}, C_i) / d(\mathbf{x}, C_j) \quad (4)$$

- Step 4: Given a specified threshold T , if the distance ratio R is less than the threshold, consider the test sample belonging to method i ; otherwise, consider the sample belonging to an unseen method.

The threshold T is determined by the subset TS_1 . We gradually increase the value of T from 0 to 1. Similarly, we perform Step 3 and Step 4 on this part of the data and calculate the average recognition accuracy at different thresholds. Finally, we select the threshold where the accuracy begins to stabilize as the final threshold T . As shown in Fig 3, the recognition accuracy increases rapidly as the threshold increases from 0 to 0.4. However, after the threshold reaches 0.4, the increase in accuracy becomes less pronounced. Therefore, we choose 0.4 as the final value for the threshold T .

3. Experiments

3.1. Database

We utilize Librispeech[32] as the source speaker dataset and VoxCeleb[33, 34] as the target speaker dataset. Within Librispeech, the train-clean section, comprising 132,553 utterances from 1,172 speakers, is chosen as training set. The dev-clean subset, consisting of 2,703 utterances from 40 speakers, is designated as the development set. While the test-clean subset,

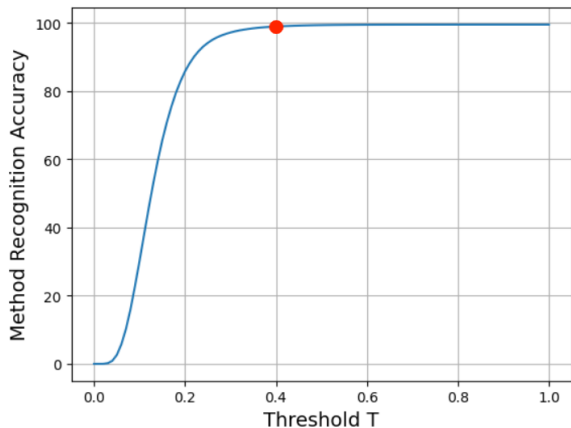

Figure 3: The accuracy of conversion method recognition on the subset $T S_1$ using different thresholds T ($0 < T < 1$).

with 2,620 utterances from 40 speakers, serves as the testing set. In VoxCeleb, our training data is sourced from the VoxCeleb2 development set, encompassing 1,092,009 utterances from 5,994 speakers. For development set, we utilize the VoxCeleb1 test set, consisting of 4,847 utterances from 40 speakers. While a subset of VoxCeleb1 development set, consisting of 4,510 utterances from 40 speakers, serves as the testing set.

To generate converted speech, we adopt the method proposed by Cai [9]. For each target speech, three source speech samples are randomly selected for voice conversion, simulating attacks from three distinct attackers on the same target speech. To optimize storage efficiency without compromising training data diversity, we partition the VoxCeleb training set into ten equal size subsets while preserving the number of speakers. Each VC method then utilizes one of these subsets as the target speech set for generating converted speech. The total number of converted speech samples for training in each VC method is approximately 327,600. For development and testing, the number of converted speech samples for each VC method is 14,622 and 13,530, respectively.

We introduce 16 any-to-any VC methods to generate the large-scale converted speech dataset as shown in Table 1. For SigVC, details of SigVC model can be found in [17], and we use the in-house implementation.

Table 1: Train and test sets and repositories for each VC method

Method	Train set	Dev set	Test set	Repository
AGAIN-VC	Train-1	Dev-1	Test-1	KimythAnly/AGAIN-VC
FreeVC	Train-2	Dev-2	Test-2	OlaWod/FreeVC
MediumVC	Train-3	Dev-3	Test-3	BrightGu/MediumVC
StyleTTS	Train-4	Dev-4	Test-4	yl4579/StyleTTS-VC
TriAAN-VC	Train-5	Dev-5	Test-5	winddori2002/TriAAN-VC
VQMIVC	Train-6	Dev-6	Test-6	Wendison/VQMIVC
SigVC	Train-7	Dev-7	Test-7	-
KNN-VC	Train-8	Dev-8	Test-8	bshall/knn-vc
BNE-PPG-VC	-	Dev-9	Test-9	liusongxiang/ppg-vc
DiffVC	-	Dev-10	Test-10	huawei-noah/Speech-Backbones
S2VC	-	Dev-11	Test-11	howard1337/S2VC
YourTTS	-	Dev-12	Test-12	Edresson/YourTTS
ControlVC	-	-	Test-13	MelissaChen15/control-vc
Diff-HierVC	-	-	Test-14	hayeong0/Diff-HierVC
LVC-VC	-	-	Test-15	wonjune-kang/lvc-vc
Wav2vec-VC	-	-	Test-16	prairie-schooner/wav2vec-vc

* All the repositories can be retrieved in the <https://github.com>.

For evaluation, We divide the enrollment and test utterance into four scenarios: (1) the same source speaker and the same target speaker, (2) the different source speakers and the same target speaker, (3) the same source speaker and the different target speakers, and (4) the different source speakers and the different target speakers. We randomly generate enrollment and test pairs according to these four scenarios and ensure that the number of pairs for each scenario is the same to create a balanced set of trials. The total number of trials for development and testing sets is 350,928 and 324,720, respectively.

3.2. Model usage

We employ two systems for model training: ResNet34[35] and MFA-Conformer [26]. For ResNet34, we configure the channels of residual blocks as $\{64, 128, 256, 512\}$. The ResNet’s output feature maps are aggregated with a global statistics pooling layer that calculates each feature map’s means and standard deviations. For the MFA-Conformer, we reduced the number of Conformer layers by half while increasing the sampling rate from 1/4 to 1/2[28], building upon the usage of a small-sized conformer encoder. The adapter structure consists of two linear layers followed by Layer Normalization and Rectified Linear Unit (ReLU) activation function as shown in Fig 1. The first linear layer projects the input data from dimension D to a hidden layer size of 128 and another linear layer is utilized to map the 128-dimensional feature representation to another 128-dimensional space. The acoustic features are 80-dimensional log Mel-filterbank energies with a frame length of 25ms and a hop size of 10ms. The extracted features are mean-normalized before feeding into the deep speaker network.

3.3. Training details

We adopt the on-the-fly data augmentation [36] to add additive background noise or convolutional reverberation noise for the time-domain waveform. The MUSAN [37] and RIR Noise [38] datasets are used as noise sources and room impulse response functions, respectively. To further diversify training samples, we apply amplification or playback speed change (pitch remains untouched) to audio signals.

Network parameters are updated using AdamW optimizer [39] with cosine decay learning rate schedule. The initial learning rate starts from $1.0e-3$, and the minimum learning rate is $1.0e-5$. We perform a linear warm-up learning rate schedule at the first epoch to prevent model vibration and speed model training. The input frame length is fixed at 200 frames. For the source speaker verification task, we employ the ArcFace classifier, with the margin and scale parameters set as 0.2 and 32, respectively. For the conversion method recognition task, we utilize a linear classifier. Additionally, we employ a pre-training strategy on the VoxCeleb2 development set to allow the model to initially learn general features, so as to obtain better performance on subsequent tasks.

4. Results

Table 3 compares the performance of our two baseline systems on source speaker verification. In this experiment, we train both models using only training set Train1 and test them on the Dev-1 test set. It can be observed that although the MFA-Conformer model has only 8.68M parameters, which is two-fifths of ResNet34, its EER on the test set reaches 9.41%, significantly better than the 13.14% of ResNet34. Additionally, we can see that the strategy of initializing model parameters with pre-

Table 2: The source speaker verification results on development sets based on the half small MFA-Conformer system with different training sets and different training strategies. VC-2 represent training set mixed by two training sets of Train-1 and Train-2. VC-4 represent training set mixed by four training sets of Train-1, Train-2, Train-3 and Train-4. VC-8 represent training set mixed with all 8 training sets of converted speech. Source speaker verification results are reported on equal error rate (EER).

	Dev-1	Dev-2	Dev-3	Dev-4	Dev-5	Dev-6	Dev-7	Dev-8	Dev-9	Dev-10	Dev-11	Dev-12
Train-1	8.480%	46.094%	35.578%	42.562%	44.958%	44.487%	49.520%	49.016%	48.804%	49.665%	37.827%	48.722%
Train-2	37.776%	7.739%	26.392%	31.536%	26.227%	34.926%	44.964%	49.016%	41.860%	46.707%	26.584%	26.794%
Train-3	31.701%	27.636%	7.444%	31.913%	27.783%	32.955%	45.908%	44.429%	44.909%	47.769%	20.053%	31.087%
Train-4	31.758%	35.797%	30.917%	6.824%	31.483%	37.245%	46.515%	46.604%	45.181%	48.702%	32.904%	36.132%
Train-5	25.556%	21.134%	21.334%	26.169%	6.762%	30.950%	45.638%	43.766%	41.534%	47.125%	18.911%	24.791%
Train-6	41.167%	28.037%	29.510%	33.572%	31.898%	12.562%	45.921%	44.090%	37.635%	40.063%	28.991%	32.621%
Train-7	42.318%	32.272%	37.068%	39.504%	37.140%	37.312%	31.002%	42.853%	39.910%	43.277%	36.121%	36.239%
Train-8	34.661%	21.058%	26.702%	31.615%	24.558%	35.098%	39.848%	28.083%	38.831%	40.668%	25.567%	25.312%
VC-2	8.753%	7.918%	23.786%	30.158%	24.512%	35.097%	44.984%	43.187%	41.651%	46.484%	23.579%	25.866%
VC-4	8.953%	8.386%	7.696%	7.405%	23.258%	33.859%	44.174%	42.955%	43.160%	47.291%	22.135%	25.798%
VC-8	9.397%	8.619%	7.671%	7.594%	7.507%	12.885%	32.484%	28.795%	34.045%	45.772%	17.209%	20.808%
Multi-VC-8	13.219%	12.518%	10.332%	10.968%	11.091%	16.799%	38.469%	35.695%	46.653%	46.308%	18.925%	45.818%
+ Adapter	9.575%	8.421%	7.629%	7.700%	7.403%	12.841%	32.113%	27.911%	32.595%	44.527%	17.409%	20.828%

trained weights from VoxCeleb2 indeed improves model performance effectively, with the MFA-Conformer model achieving an EER of 8.48%.

Table 3: Comparison of performance between ResNet34-GSP and MFA-Conformer half small. Trained solely with training set Train-1, and tested on the Dev-1.

Model	Parameters	Dev-1
ResNet34-GSP + VoxCeleb2 pre-train	21.54M	13.14% 10.68%
MFA-Conformer half small + VoxCeleb2 pre-train	8.68M	9.41% 8.48%

Table 2 and 4 reports the source speaker verification results based on the half small MFA-Conformer system. The performances are displayed from two aspects: different training set and different training strategies.

Table 4: The source speaker verification results on testing sets based on the half small MFA-Conformer system with VC-8.

Test-1	Test-2	Test-3	Test-4	Test-5	Test-6	Test-7	Test-8
9.786%	10.645%	6.999%	7.606%	6.732%	10.756%	32.902%	29.303%
Test-9	Test-10	Test-11	Test-12	Test-13	Test-14	Test-15	Test-16
34.593%	45.415%	18.714%	22.501%	36.657%	20.368%	9.530%	27.308%

As we can see, when training and testing with generated speech from the same VC model, systems trained on Train-1~Train-6 all achieved good EER results, which are 8.480%, 7.739%, 7.444%, 6.824%, 6.762%, 12.562% respectively. Due to the significant removal of source speaker information by the SigVC and KNN-VC VC methods, extracting the source speaker information for verification from converted speech generated by both systems is more challenging. Therefore, systems trained on Train-7 and Train-8 ultimately achieve degraded results, with EER values of 31.002% and 28.083%, respectively.

Due to the inherent differences among various conversion methods, speech generated by different conversion methods can be considered data from different domains. When training data from different domains are mixed, it inevitably leads to a slight decrease in performance on each domain. We can observe that as the number of conversion methods increases, the EER of systems trained on Train-1, VC-2, VC-4, and VC-8 on the Dev-

1 set reduce, with values of 8.480%, 8.753%, 8.953%, and 9.397% respectively. However, the generalization ability of system tends to improve when exposed to a greater variety of conversion types. For example, we can observe that systems trained on Train-1, VC-2, and VC-4 exhibit decreasing EER values on the Dev-5 set, with values of 44.958%, 24.512%, and 23.258%, respectively. Similar trends are evident across other development sets, suggesting an enhanced performance for previously unseen conversion methods.

For multi-task learning, the differences among different tasks are clear. System Multi-VC-8 extends the system VC-8 by simultaneously performing source speaker verification and method recognition on the extracted embeddings, its performance in source speaker verification significantly degrades. On the development sets of each VC method, the EER experiences a performance decrease of 3-4 points. After we add the adapter module, due to the ability of the adapter to fine-tune the outputs of each layer of the consistency model and align them more closely with the target task. We can see that the system maintains comparable performance to system VC-8 on the source speaker verification task while achieving 100% recognition accuracy on the seen methods as shown in Table 5. Furthermore, for the open-set method recognition problem, we employed the OSNN method. It can be observed that the system ultimately achieves an average recognition accuracy of 98.36% on the seen methods and 99.16% on the unseen methods.

Table 5: Average method recognition accuracy of the seen and the unseen VC methods on the development sets.

Model	Average Acc. on Seen Methods	Average Acc. on Unseen Methods
Multi-VC-8 with Adapter	100%	-
+ OSNN	98.36%	99.16%

5. Conclusion

In this paper, we generate and release a large-scale converted speech database with 16 common any-to-any VC methods and train a batch of baseline systems based on MFA-Conformer for source speaker verification. Also, we introduce a related task called conversion method recognition and employ an adapter-based multi-task learning approach to simultaneously learn the source speaker verification task and the conversion method

recognition task. Furthermore, we investigate and address the open-set conversion method recognition problem through an open-set nearest neighbor approach. Our future work will focus on leveraging accurately identified VC method information to enhance the performance of source speaker verification.

6. References

- [1] D. Snyder, D. Garcia-Romero, G. Sell, D. Povey, and S. Khudanpur, "X-vectors: Robust dnn embeddings for speaker recognition," in *Proc. of ICASSP*, 2018, pp. 5329–5333.
- [2] B. Desplanques, J. Thienpondt, and K. Demuynck, "ECAPA-TDNN: Emphasized Channel Attention, Propagation and Aggregation in TDNN Based Speaker Verification," in *Proc. of Interspeech*, 2020, pp. 3830–3834.
- [3] Z. Wu, T. Kinnunen, N. Evans, J. Yamagishi, C. Hanilçi, M. Sahidullah, and A. Sizov, "Asvspoof 2015: the first automatic speaker verification spoofing and countermeasures challenge," in *Proc. of Interspeech*, 2015.
- [4] T. Kinnunen, M. Sahidullah, H. Delgado, M. Todisco, N. Evans, J. Yamagishi, and K. A. Lee, "The asvspoof 2017 challenge: Assessing the limits of replay spoofing attack detection," in *Proc. of Interspeech*, 2017.
- [5] M. Todisco, X. Wang, V. Vestman, M. Sahidullah, H. Delgado, A. Nautsch, J. Yamagishi, N. Evans, T. Kinnunen, and K. A. Lee, "Asvspoof 2019: Future horizons in spoofed and fake audio detection," in *Proc. of Interspeech*, 2019.
- [6] J. Yamagishi, X. Wang, M. Todisco, M. Sahidullah, J. Patino, A. Nautsch, X. Liu, K. A. Lee, T. Kinnunen, N. Evans *et al.*, "Asvspoof 2021: accelerating progress in spoofed and deepfake speech detection," *arXiv preprint arXiv:2109.00537*, 2021.
- [7] Z. Wu, N. Evans, T. Kinnunen, J. Yamagishi, F. Alegre, and H. Li, "Spoofing and countermeasures for speaker verification: A survey," *Speech Commun.*, vol. 66, pp. 130–153, 2015.
- [8] F. Alegre, A. Amehraye, and N. Evans, "Spoofing countermeasures to protect automatic speaker verification from voice conversion," in *Proc. of Interspeech*, 2013, pp. 3068–3072.
- [9] D. Cai, Z. Cai, and M. Li, "Identifying source speakers for voice conversion based spoofing attacks on speaker verification systems," in *Proc. of ICASSP*, 2023, pp. 1–5.
- [10] Y.-H. Chen, D.-Y. Wu, T.-H. Wu, and H.-y. Lee, "Again-vc: A one-shot voice conversion using activation guidance and adaptive instance normalization," in *Proc. of ICASSP*, 2021, pp. 5954–5958.
- [11] J. Li, W. Tu, and L. Xiao, "Freevc: Towards high-quality text-free one-shot voice conversion," in *Proc. of ICASSP*, 2023, pp. 1–5.
- [12] Y. Gu, Z. Zhang, X. Yi, and X. Zhao, "Mediumvc: Any-to-any voice conversion using synthetic specific-speaker speeches as intermediate features," *arXiv preprint arXiv:2110.02500*, 2021.
- [13] Y. A. Li, C. Han, and N. Mesgarani, "Styletts: A style-based generative model for natural and diverse text-to-speech synthesis," *arXiv preprint arXiv:2205.15439*, 2022.
- [14] H. J. Park, S. W. Yang, J. S. Kim, W. Shin, and S. W. Han, "Triaan-vc: Triple adaptive attention normalization for any-to-any voice conversion," in *Proc. of ICASSP*. IEEE, 2023, pp. 1–5.
- [15] D. Wang, L. Deng, Y. T. Yeung, X. Chen, X. Liu, and H. Meng, "VQMIVC: Vector Quantization and Mutual Information-Based Unsupervised Speech Representation Disentanglement for One-Shot Voice Conversion," in *Proc. of Interspeech*, 2021, pp. 1344–1348.
- [16] M. Baas, B. van Niekerk, and H. Kamper, "Voice conversion with just nearest neighbors," in *Proc. Interspeech*, 2023.
- [17] H. Zhang, Z. Cai, X. Qin, and M. Li, "Sig-vc: A speaker information guided zero-shot voice conversion system for both human beings and machines," in *Proc. of ICASSP*, 2022, pp. 6567–65 571.
- [18] S. Liu, Y. Cao, D. Wang, X. Wu, X. Liu, and H. Meng, "Any-to-many voice conversion with location-relative sequence-to-sequence modeling," *IEEE/ACM Transactions on Audio, Speech, and Language Processing*, vol. 29, pp. 1717–1728, 2021.
- [19] V. Popov, I. Vovk, V. Gogoryan, T. Sadekova, M. S. Kudinov, and J. Wei, "Diffusion-based voice conversion with fast maximum likelihood sampling scheme," in *Proc. of ICLR*, 2022.
- [20] J. hao Lin, Y. Y. Lin, C.-M. Chien, and H. yi Lee, "S2VC: A Framework for Any-to-Any Voice Conversion with Self-Supervised Pretrained Representations," in *Proc. of Interspeech*, 2021, pp. 836–840.
- [21] E. Casanova, J. Weber, C. D. Shulby, A. C. Junior, E. Gölge, and M. A. Ponti, "Yourtts: Towards zero-shot multi-speaker tts and zero-shot voice conversion for everyone," in *Proc. of ICML*. PMLR, 2022, pp. 2709–2720.
- [22] M. Chen and Z. Duan, "Controlvc: Zero-shot voice conversion with time-varying controls on pitch and speed," *arXiv preprint arXiv:2209.11866*, 2022.
- [23] H.-Y. Choi, S.-H. Lee, and S.-W. Lee, "Diff-hiervc: Diffusion-based hierarchical voice conversion with robust pitch generation and masked prior for zero-shot speaker adaptation," *International Speech Communication Association*, pp. 2283–2287, 2023.
- [24] W. Kang, M. Hasegawa-Johnson, and D. Roy, "End-to-end zero-shot voice conversion with location-variable convolutions," *arXiv preprint arXiv:2205.09784*, 2022.
- [25] J. Lim and K. Kim, "Wav2vec-vc: Voice conversion via hidden representations of wav2vec 2.0," in *Proc. of ICASSP*, 2024, pp. 10 326–10 330.
- [26] Y. Zhang, Z. Lv, H. Wu, S. Zhang, P. Hu, Z. Wu, H. yi Lee, and H. Meng, "MFA-Conformer: Multi-scale Feature Aggregation Conformer for Automatic Speaker Verification," in *Proc. of Interspeech*, 2022, pp. 306–310.
- [27] J. Yi, J. Tao, R. Fu, X. Yan, C. Wang, T. Wang, C. Y. Zhang, X. Zhang, Y. Zhao, Y. Ren *et al.*, "Add 2023: the second audio deepfake detection challenge," *arXiv preprint arXiv:2305.13774*, 2023.
- [28] D. Cai and M. Li, "Leveraging asr pretrained conformers for speaker verification through transfer learning and knowledge distillation," *arXiv preprint arXiv:2309.03019*, 2023.
- [29] P. R. Mendes Júnior, R. M. De Souza, R. d. O. Werneck, B. V. Stein, D. V. Pazinato, W. R. De Almeida, O. A. Penatti, R. d. S. Torres, and A. Rocha, "Nearest neighbors distance ratio open-set classifier," *Machine Learning*, vol. 106, no. 3, pp. 359–386, 2017.
- [30] J. Pfeiffer, I. Vulić, I. Gurevych, and S. Ruder, "Mad-x: An adapter-based framework for multi-task cross-lingual transfer," in *Proc. of EMNLP*, 2020, pp. 7654–7673.
- [31] J. Pilault, A. E. hattami, and C. Pal, "Conditionally adaptive multi-task learning: Improving transfer learning in {nlp} using fewer parameters & less data," in *Proc. of ICLR*, 2021.
- [32] V. Panayotov, G. Chen, D. Povey, and S. Khudanpur, "Librispeech: an asr corpus based on public domain audio books," in *Proc. of ICASSP*, 2015, pp. 5206–5210.
- [33] A. Nagrani, J. S. Chung, and A. Zisserman, "Voxceleb: a large-scale speaker identification dataset," in *Proc. of Interspeech*, 2017.
- [34] J. S. Chung, A. Nagrani, and A. Zisserman, "VoxCeleb2: Deep Speaker Recognition," in *Proc. of Interspeech*, 2018, pp. 1086–1090.
- [35] K. He, X. Zhang, S. Ren, and J. Sun, "Deep residual learning for image recognition," in *Proc. of CVPR*, 2016, pp. 770–778.
- [36] W. Cai, J. Chen, J. Zhang, and M. Li, "On-the-Fly Data Loader and Utterance-Level Aggregation for Speaker and Language Recognition," *IEEE/ACM Transactions on Audio, Speech, and Language Processing*, pp. 1038–1051, 2020.
- [37] D. Snyder, G. Chen, and D. Povey, "MUSAN: A Music, Speech, and Noise Corpus," *arXiv:1510.08484*.

- [38] T. Ko, V. Peddinti, D. Povey, M. Seltzer, and S. Khudanpur, "A study on data augmentation of reverberant speech for robust speech recognition," in *Proc. of ICASSP*, 2017, pp. 5220–5224.
- [39] I. Loshchilov and F. Hutter, "Fixing weight decay regularization in adam," in *Proc. of ICLR*, 2019.