

# On the composable security of weak coin flipping

Jiawei Wu (吴家为)<sup>1</sup>, Yanglin Hu (胡杨林)<sup>1</sup>, Akshay Bansal<sup>2</sup>, and Marco Tomamichel<sup>1,3</sup>

<sup>1</sup>Centre for Quantum Technologies, National University of Singapore, Singapore

<sup>2</sup>Department of Computer Science, Virginia Polytechnic Institute and State University, United States

<sup>3</sup>Department of Electrical and Computer Engineering, National University of Singapore, Singapore

Weak coin flipping is a cryptographic primitive in which two mutually distrustful parties generate a shared random bit to agree on a winner via remote communication. While a stand-alone secure weak coin flipping protocol can be constructed from noiseless communication channels, its composability has not been explored. In this work, we demonstrate that no weak coin flipping protocol can be abstracted into a simple black box resource with composable security. Despite this, we also establish the overall stand-alone security of weak coin flipping protocols under sequential composition.

## 1 Introduction

### Motivation and background

Cryptographic systems or protocols are expected to guarantee security even when composed with multiple other cryptographic systems. To illustrate this, consider a cryptographic protocol designed to perform secure communication between two parties while leaking at most the length of the communicated message. One possible way to construct such a scheme is to first use a system that generates and distributes secret keys amongst the users and then use another system that pads the key with the intended message to be sent to the receiver (the so-called one-time pad). While it is relatively straightforward to see that a buggy implementation that compromises the security of key distribution or one-time pad would result in overall insecure communication, it is at times difficult to formally argue that the final composition results in a secure communication channel when both the constituent systems (key distribution and one-time pad) are assumed secure in isolation. Indeed, it might seem natural to use small accessible information of the distributed key as the security criterion for key distribution. However, the fact that key distribution using this criterion is secure in isolation does not imply that the final communication protocol is secure [1], due to the data locking effect [2]. We thus say that composability fails for this security criterion.

Several frameworks have been proposed that are intended to analyze compositions of cryptographic systems, starting with Canetti's seminal Universally Composable (UC)

---

Jiawei Wu (吴家为): [constchar0212@gmail.com](mailto:constchar0212@gmail.com)

Yanglin Hu (胡杨林): [yanglin.hu@u.nus.edu](mailto:yanglin.hu@u.nus.edu)

Akshay Bansal: [akshaybansal14@gmail.com](mailto:akshaybansal14@gmail.com)

Marco Tomamichel: [marco.tomamichel@nus.edu.sg](mailto:marco.tomamichel@nus.edu.sg), <https://marcotom.info/>

security framework [3, 4]. Since then, several extensions and variants have emerged (see, e.g., [5, 6, 7, 8]). We focus here on the model of Abstract Cryptography (AC) by Maurer and Renner [9, 10]. In contrast to the previous frameworks, the latter is a top-down axiomatic approach and is intended to provide better insights via abstraction of a given complex cryptographic system and will thus be most suitable for our purposes. The security in the AC framework is built on simulation-based security. Here, for a given system to be deemed secure, it suffices to ensure that all adversarial attacks on the system can be simulated on an ideal system. Therefore, to prove the security of any multi-party protocol in the AC framework, one needs to show the existence of such a simulator simulating all possible adversary attacks.

The cryptographic setting we consider in this work is a two-party primitive called weak coin flipping (WCF). Informally speaking, in WCF two mutually distrustful parties, say Alice and Bob, need to agree on a binary outcome even though the two parties have opposite preferences. The protocol is deemed secure if it produces a fair coin toss in case both parties are honest and a dishonest party can at most bias the honest party’s outcome towards their preference. The WCF task is fundamentally different from the other commonly studied tasks such as strong coin flipping (SCF), bit commitment (BC), oblivious transfer, or more generally, secure function evaluation. While the latter protocols are shown to be insecure with an unbounded adversary [11, 12, 13, 14, 15], it is possible to construct weak coin flipping protocols with quantum communication that exhibit almost perfect security with arbitrarily small bias [16]. The explicit protocols which are shown to have an arbitrarily small bias are developed in [17, 18, 19]. The security notion employed in these results, known as information-theoretic security, allows an adversary to enjoy unlimited resources (i.e. the adversary has no restrictions on its computational power or use of memory, etc.). It is well-studied for a range of different cryptographic tasks and, in most cases, is stronger than other commonly studied security definitions such as computational [20, 21, 22], bounded storage [23, 24, 25] or even game-based [26, 27], where an adversary can perform attacks in only some prescribed ways.

Previously, it was shown that WCF enjoys information-theoretic stand-alone security, i.e., it is secure as a single protocol instance in isolation [16, 17, 18, 19]. However, while WCF itself is of limited interest, it is mostly a powerful tool in constructing optimal protocols for several other primitives such as bit commitment [28] and strong coin flipping [29]. However, such constructions would require more than stand-alone security and it is still unclear if WCF protocols have composable security when combined with other cryptographic protocols.

## Contributions

Our main contributions encompass two negative theorems and one positive theorem. In Theorem 5, we demonstrate the impossibility of constructing a typical black-box WCF resource analogous to the widely-used SCF resource [30] (see Definition 4) from noiseless communication channels in the AC framework. This WCF resource generates a random bit for both parties, allowing the cheating party to learn the bit in advance and bias it towards their preferred direction. It was shown that the widely-used SCF resource cannot be achieved in the AC framework [31], but the result for the similar WCF resource remains unknown until this work. We state Theorem 5 here informally.

**Theorem 1** (Informal). *The typical black-box WCF resource with composable security cannot be constructed from noiseless communication channels in the AC framework.*

To prove Theorem 5, we show that WCF protocols using noiseless communication

channels are vulnerable to the man-in-the-middle attack when composed in parallel. As a result, the typical black-box WCF resource cannot be constructed by any WCF protocol from noiseless communication channels in the AC framework.

Theorem 5 shows the impossibility of the typical black-box WCF resource in the AC framework. However, we can still define an alternative WCF resource at the cost of increasing the interaction complexity. Nevertheless, such an alternative WCF resource that can be constructed from noiseless communication channels must be extremely complicated in terms of its interaction complexity, as is shown in Theorem 6. Replacing an actual protocol with an ideal resource intends to simplify the analysis; therefore, it is meaningless to study such an alternative WCF resource. Here is the informal statement of Theorem 6.

**Theorem 2** (Informal). *Any black-box WCF resource with composable security constructed from noiseless communication channels in the AC framework must have high interaction complexity.*

The proof of Theorem 6 consists of two steps. First, we show that an alternative WCF resource with composable security constructed from noiseless communication channels implies a WCF protocol with the same interaction complexity as the alternative WCF resource. Then together with the exponential lower bound on the interaction complexity of WCF protocols, we conclude that a WCF resource with a low interaction complexity can not exist.

Next, we extend the classical version of the sequential composition theorem [32, Theorem 7.4.3] to the quantum case. We find a sufficient condition called global security where WCF and other modules can be composed into a larger system with stand-alone security. A composition between WCF and other components is globally secure if there is no correlation between the outcomes of WCF and other components. We thus show in Theorem 10 that global security holds when WCF and all other components are composed in a strict causal order. That is, there is no other component running concurrently with WCF. The constructions for optimal SCF and optimal BC exactly satisfy global security.

**Theorem 3** (Informal). *A primitive constructed from WCF with stand-alone security under strict sequential composition maintains its stand-alone security.*

The idea to prove Theorem 10 is by contradiction. Assume that there is some correlation between outcomes of WCF with stand-alone security and other components under sequential composition. Using the information carried from previous components to WCF, we can construct an attack breaking the stand-alone security of WCF. This contradicts our assumption and thus proves Theorem 10.

## Related work

*Causality in the composable framework.* Some early works [33, 34] developed the paradigm that only allows for sequential composition, where protocols are executed one after another. Canetti [3] relaxed “sequential” composition to modular composition in the UC framework, where the former is a special case of the latter. The AC framework [9, 10] takes a top-down hierarchy. Only the connection of abstract systems is considered at the top level, and the execution order is left at the lower level specification. Under the AC framework, the causal box model [35] provides the causal order specification that allows for quantum superposition of different orders.

*Concerning concurrent composition.* Literature [24, 25] addresses the difficulty of concurrent parallel composition in the UC framework and the bounded storage model. The

composability of BC was discussed in [36]. They define the weak binding security of BC in a stand-alone rather than composable manner and propose a counterexample where the string commitment constructed from multiple instances of BC is insecure. In a previous model of general cryptographic protocols [32, Section 7.3], concurrent calls to an oracle (resource) are also forbidden. This restriction primarily stems from the formulation of syntax in that model rather than an explicit security concern.

*Coin flipping within the AC framework.* To study the composability of SCF, Demay and Maurer [30] propose an SCF resource and prove that it can be constructed from a BC resource. However, this resource is shown to be impossible to construct from noiseless communication channels, even in a relativistic setting [31].

## 2 Preliminaries

### 2.1 The abstract cryptography framework

The building blocks of the framework are resources, converters (protocols), and distinguishers. Resources are cryptographic functionalities, and converters transform one resource into another. Distinguishers distinguish resources from each other. The framework is feasible to describe multiparty functionalities, but we only focus on two-party ones here.

- A *resource*, denoted by  $R$ , has one interface accessible to each party. Each party can send inputs, receive outputs, perform operations and give instructions via the corresponding interface. In two-party cryptography, it is necessary to consider three different behaviours  $R$ ,  $R_A$  and  $R_B$  of a resource, where  $R$ ,  $R_A$  and  $R_B$  correspond to the case where both are honest, where Alice is dishonest, and where Bob is dishonest, respectively. We use  $\mathcal{R} = (R, R_A, R_B)$  to denote a resource compactly.
- A *converter*, denoted by a lower-case Greek letter  $\alpha$ , is a cryptographic system with an inner interface connected to an interface of a resource and an outer interface to a party. The set of all converters is denoted by  $\Sigma$ . Each party can instruct the converter on the outer interface to execute specific tasks on the inner interface. A converter  $\alpha$  can convert one resource  $R$  into another resource  $S$  by connecting its inner interface to one interface of the resource  $R$ . The interfaces of the resource  $S$  consist of the unconnected interface of the resource  $R$  and the outer interface of the converter  $\alpha$ . We denote the connection between the converter  $\alpha$  and the left-side (right-side) interface of the resource  $R$  by  $\alpha R$  ( $R\alpha$ ).
- A *protocol*  $\pi = (\pi_A, \pi_B)$  consists of Alice's converter  $\pi_A$  and Bob's converter  $\pi_B$ .  $\pi_A$  and  $\pi_B$  are operations that honest Alice and Bob should follow when building one resource from another. By connecting each converter to the corresponding interface, the protocol  $\pi$  can build a required resource  $S$  from a given resource  $R$  if  $S = \pi_A R \pi_B$ . For example, suppose  $R$  is a binary symmetric channel resource and  $(\pi_A, \pi_B)$  is an encoder-decoder pair corresponding to a proper error-correcting code. Then one can construct a noiseless channel resource as  $S = \pi_A R \pi_B$ .
- A *distinguisher*, denoted by  $\mathcal{D}$ , is an agent who can access both interfaces of a resource. Given one of two resources  $R$  and  $S$  uniformly at random, a distinguisher guesses whether the resource is  $R$  or  $S$  by interacting with it. The distinguishing advantage of the above task is defined as

$$d(R, S) = \sup_{\mathcal{D}} |\Pr[\mathcal{D}(R) = 0] - \Pr[\mathcal{D}(S) = 0]|. \quad (1)$$

The distinguishing advantage is a pseudo metric between two resources, satisfying the symmetry and triangle inequality properties. When  $d(R, S) \leq \delta$ , we also write  $R \approx_\delta S$ .

With these building blocks, we define composable security for two-party functionalities.

**Definition 1** (Composable security). *A protocol  $\pi = (\pi_A, \pi_B)$  constructs resource  $\mathcal{S} = (S, S_A, S_B)$  out of resource  $\mathcal{R} = (R, R_A, R_B)$  with distinguishing advantage  $\delta$  if the following conditions are satisfied*

1. *Correctness*

$$S \approx_\delta \pi_A R \pi_B. \quad (2)$$

2. *Security against dishonest Bob*

$$\exists \sigma_B \in \Sigma, S_B \sigma_B \approx_\delta \pi_A R_B. \quad (3)$$

3. *Security against dishonest Alice*

$$\exists \sigma_A \in \Sigma, \sigma_A S_A \approx_\delta R_A \pi_B. \quad (4)$$

This construction is denoted by  $\mathcal{R} \xrightarrow{\pi, \delta} \mathcal{S}$ . Alternatively, we say that  $\mathcal{S}$  is an abstraction of  $\pi$  based on  $\mathcal{R}$ , or that  $\mathcal{S}$  abstracts  $\pi$  based on  $\mathcal{R}$ .

In the previous definition,  $\sigma_A$  and  $\sigma_B$  are called simulators. Intuitively, the simulators here ensure that any valid cheating strategy for resource  $\mathcal{R}$  could be mapped onto some cheating strategy for resource  $\mathcal{S}$ . For instance, if dishonest Bob deviates from the protocol  $\pi_B$  by following  $\pi'_B$  instead, then, according to Eq. (3), this is equivalent to the action  $\sigma_B \pi'_B$  on resource  $S_B$ . For a detailed description of simulators and the related security notions in cryptography, we refer to the tutorial [37].

When  $\mathcal{R}$  is a noiseless communication channel, the conditions can be simplified as

$$S \approx_\delta \pi_A \pi_B, \quad (5)$$

$$\exists \sigma_B \in \Sigma, S_B \sigma_B \approx_\delta \pi_A, \quad (6)$$

$$\exists \sigma_A \in \Sigma, \sigma_A S_A \approx_\delta \pi_B. \quad (7)$$

## 2.2 The quantum comb model

A quantum comb [38, 39] is a general quantum information processing system with internal memory that processes the incoming messages one by one. An example of quantum comb is shown in Fig. 1. It is common to model the building blocks in the AC framework as quantum comb. If a protocol can be modeled with the quantum comb model (QCM), it is called a QCM protocol. Note that all existing WCF protocols can be classified as QCM protocols.

The interaction complexity of a QCM protocol  $\pi$ , denoted by  $\text{Intcom}(\pi)$ , is defined as its communication rounds. As an example, for a protocol  $\pi$  modeled by Fig. 1,  $\text{Intcom}(\pi) = n$ . For resources such as  $S_A$  and  $S_B$ , their interaction complexity refers to the communication rounds at the adversary's side. For example, the interaction complexity of WCF resource  $S_A$  in Fig 3(b) is the rounds at the left side, which is 1.

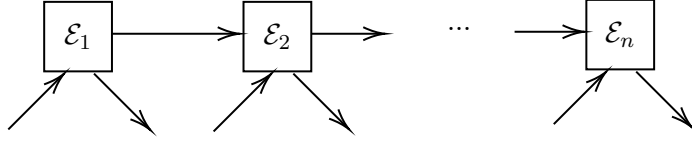

Figure 1: An example of quantum comb.  $\mathcal{E}_i$  is a quantum operation. The lines with an arrow are quantum states. The unconnected lines are pairs of input and output messages.

### 2.3 The causal box model

The causal box model [35] is a more general specification of building blocks in the AC framework. The causal box model presents the causal structure of the messages sent or received by these building blocks. The quantum comb model can be treated as a special case of the causal box model.

In the causal box model, the abstract blocks are modeled as causal boxes. A causal box is an information processing system with input and output wires. Each message on a wire is described by a quantum state on space  $\mathcal{H} \otimes l^2(\mathcal{T})$ , where  $\mathcal{T}$  is a partially ordered set (poset) corresponding to the order of messages and  $l^2(\mathcal{T})$  is the set of all functions  $\mathcal{T} \rightarrow \mathbb{C}$  with bounded  $L^2$  norm. Note that  $\mathcal{T}$  cannot be simply interpreted as time, which is totally ordered. For generality, a wire may contain arbitrarily many messages. Therefore, the wire space is defined as the Fock space of the message space

$$\mathcal{F}_{\mathcal{H}}^{\mathcal{T}} := \bigoplus_{n=0}^{\infty} \vee^n (\mathcal{H} \otimes l^2(\mathcal{T})), \quad (8)$$

where  $\vee^n \mathcal{H}$  denotes the symmetric subspace of  $\mathcal{H}^{\otimes n}$  and  $l^2(\mathcal{T})$  is the space of square summable sequence on  $\mathcal{T}$ . Sometimes we abuse the notation by writing  $\mathcal{F}_{\mathcal{H}_A}^{\mathcal{T}}$  as  $\mathcal{F}_A^{\mathcal{T}}$ . With this definition, wires can be merged or split, i.e., for  $\mathcal{H}_A = \mathcal{H}_{A_1} \oplus \mathcal{H}_{A_2}$ ,

$$\mathcal{F}_A^{\mathcal{T}} = \mathcal{F}_{A_1}^{\mathcal{T}} \otimes \mathcal{F}_{A_2}^{\mathcal{T}}. \quad (9)$$

A causal box is formally defined as a completely positive and trace-preserving (CPTP) map from the input wire  $X$  to the output wire  $X'$ . This map should further respect the causality condition, i.e., the output message at  $t' \in \mathcal{T}$  only depends on the input messages at  $t \in \mathcal{T}$  where  $t \preceq t'$ . A precise definition can be found in Appendix A.

The composition of causal boxes consists of parallel composition and loops. The parallel composition of causal boxes  $\Phi$  and  $\Psi$ ,  $\Phi \parallel \Psi$  is defined as the map  $\Phi \otimes \Psi$ . Due to Equation (9), this map's input and output space are still valid wires. A loop connects segments with the same dimension of the input and output wires. An interface labelled by  $x$  of a resource or a converter  $\Phi$ , denoted by  $\text{int}_x(\Phi)$ , is specified by a set of wires, possibly including both input and output wires. For example, the inner and outer interfaces of a converter  $\alpha$  are denoted by  $\text{int}_{in}(\alpha)$  and  $\text{int}_{out}(\alpha)$ , respectively. Two interfaces  $\text{int}_a(\Phi), \text{int}_b(\Psi)$  are compatible if there exists a bijection  $P : \text{int}_a(\Phi) \leftrightarrow \text{int}_b(\Psi)$  such that each pair of wires consists of an input wire and an output wire with the same dimension.

### 2.4 Weak coin flipping

Here we formulate WCF protocols with causal boxes.

**Definition 2** (Weak coin flipping protocol). *A weak coin flipping protocol using noiseless communication channels is a pair of converters  $\pi = (\pi_A, \pi_B)$  with compatible inner interfaces.  $\pi_A$  ( $\pi_B$ ) has one output wire on the outer interface and only outputs a single*

classical bit at  $t_a$  ( $t_b$ ). The poset  $\mathcal{T}$  of the protocol is bounded both from above and below, i.e.,  $\exists t_0 \in \mathcal{T}$ , such that  $\forall t \in \mathcal{T}$ , it holds that  $t_0 \preceq t$ ,  $t \preceq t_a$  and  $t \preceq t_b$ .

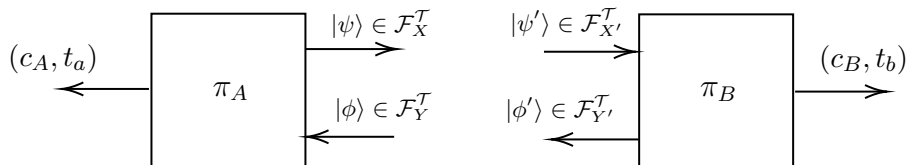

Figure 2: A general model for coin flipping protocol using noiseless communication channels. The message spaces  $X, Y$  and  $X', Y'$  are of the same dimension, respectively.

In a WCF protocol, we say Alice wins if  $c_A = c_B = 0$  while Bob wins if  $c_A = c_B = 1$ , which means Alice only wants to prevent Bob from biasing  $c_A$  towards 1 and Bob only wants to prevent Alice from biasing  $c_B$  towards 0.

Notably, in the definition of weak coin flipping, players are not allowed to abort, whereas in strong coin flipping, aborting is required. This distinction arises because, in the weak coin flipping scenario, if a player detects malicious behavior, they can simply declare themselves the winner.

**Definition 3** (Stand-alone security of WCF). *Let  $\epsilon \leq z$  and  $z \in [0, \frac{1}{2}]$ . A coin flipping protocol  $\pi = (\pi_A, \pi_B)$  is a  $z$ -unbalanced  $\epsilon$ -biased WCF protocol (with stand-alone security), denoted by  $\text{WCF}(z, \epsilon)$ , if the following conditions are satisfied:*

(S1) *The composition  $\pi_A \pi_B$  by connecting the inner interface of  $(\pi_A, \pi_B)$  outputs  $(c_A, c_B)$  with a probability of*

$$\Pr[c_A = c_B = 0] = z, \quad \Pr[c_A = c_B = 1] = 1 - z. \quad (10)$$

(S2) *For any converter  $\alpha$  compatible with the inner interface with  $\pi_B$ , the composition  $\alpha \pi_B$  outputs  $c_B = 0$  with a probability of*

$$\Pr[c_B = 0] \leq z + \epsilon. \quad (11)$$

(S3) *For any converter  $\beta$  compatible with inner interface with  $\pi_A$ , the composition  $\pi_A \beta$  outputs  $c_A = 1$  with a probability of*

$$\Pr[c_A = 1] \leq 1 - z + \epsilon. \quad (12)$$

We call a protocol balanced if  $z = \frac{1}{2}$  and unbiased if  $\epsilon = 0$ .

### 3 Weak coin flipping is not universally composable secure

This section shows that WCF cannot be universally composable secure in the AC framework. The result contains two parts. First, we consider a specific WCF resource derived from a simple but widely adapted SCF resource [30] and show that this specific WCF resource cannot be constructed from noiseless communication channel. Nevertheless, this result does not exclude the existence of other types of resources that can be constructed with, say, the protocol in [18]. Then our second result shows that, for any WCF protocol with enough stand-alone security, there does not exist any useful abstraction. Usefulness here means that the resource fully expresses the functionality of WCF and its interaction complexity is low.

### 3.1 Impossibility for a specific resource

**Definition 4** ( $z$ -unbalanced  $\epsilon$ -biased WCF resource). *Let  $\epsilon \in [0, z]$  and  $z \in [0, \frac{1}{2}]$ . A  $z$ -unbalanced  $\epsilon$ -biased WCF resource is characterized by a tuple  $\mathcal{S} = (S, S_A, S_B)$ , as is shown in Figure 3.*

1.  $S$  describes the case when both Alice and Bob are honest. In this case, both party obtains a random bit  $c$  satisfying

$$\Pr[c = 0] = z, \quad \Pr[c = 1] = 1 - z. \quad (13)$$

2.  $S_A$  describes the case when Alice is dishonest and Bob is honest.  $S_A$  outputs a random bit  $c'$  subject to the distribution  $(z, 1 - z)$  at  $t'_0$  and receives two bits  $b', p'$  at  $t'_1$  at the left interface. Then it outputs a bit  $c_B$  at the right interface. If  $p' = 1$ , then  $c_B = 1$ , else the probability distribution of  $c_B$  follows

$$\Pr[c_B = b'] = \frac{\epsilon}{1 - z}, \quad \Pr[c_B = c'] = 1 - \frac{\epsilon}{1 - z}. \quad (14)$$

The causality condition is  $t'_0 \prec t'_1 \prec t_b$ .

3.  $S_B$  works similarly as  $S_A$ . The causality condition is  $t''_0 \prec t''_1 \prec t_a$ .

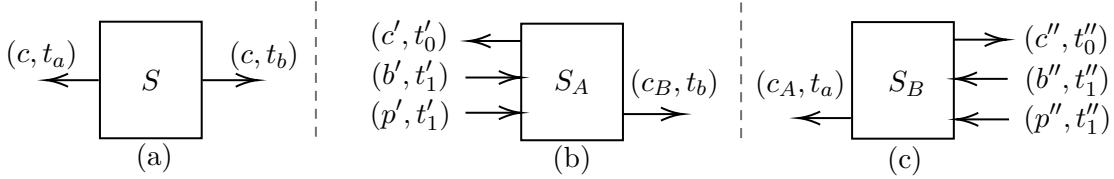

Figure 3: (a), (b) and (c) respectively show the components  $S, S_A, S_B$  of the WCF resource  $\mathcal{S}$ . Every message is assigned an element of the order set to indicate the causal order.

The resource in Definition 4 is a reasonable and simple WCF resource. The following theorem indicates that it cannot be constructed from noiseless communication channel.

**Theorem 5.** *There does not exist a protocol  $\pi = (\pi_A, \pi_B)$  which can construct an  $z$ -unbalanced  $\epsilon$ -biased WCF resource  $\mathcal{S} = (S, S_A, S_B)$  with a distinguishing advantage  $\delta < \frac{1}{3}z(1 - z - \epsilon)$ .*

*Proof.* Suppose that there is a protocol  $\pi = (\pi_A, \pi_B)$  that constructs an ideal  $z$ -unbalanced  $\epsilon$ -biased WCF resource  $\mathcal{S} = (S, S_A, S_B)$  with a distinguishing advantage  $\delta$  (without loss of generality we assume  $z \in [0, \frac{1}{2}]$ ). Combining the security conditions for Alice and Bob, respectively, followed by the triangle inequality, we obtain

$$\exists \sigma \in \Sigma, S_B \sigma S_A \approx_{2\delta} \pi_A \pi_B, \quad (15)$$

where  $\sigma = \sigma_B \sigma_A$ . Applying the correctness followed again by the triangle inequality, we proceed to

$$\exists \sigma \in \Sigma, S_B \sigma S_A \approx_{3\delta} S. \quad (16)$$

This relation is illustrated in Figure 4.

We now show that, however, there does not exist  $\sigma$  such that  $\delta < \frac{1}{12}$ . Note that the best choice of causal order for  $\sigma$  is  $t'_0 \prec t'_1, t'_0 \prec t''_1, t''_0 \prec t'_1, t''_0 \prec t''_1$  since it can maximize the use of information of  $c', c''$ .



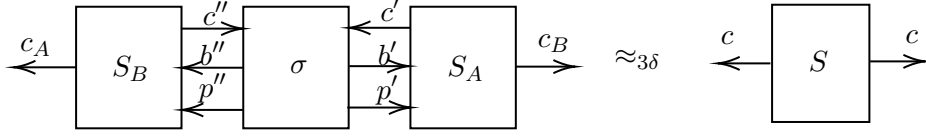

Figure 4: The composition of two ideal WCF resources.

The most general operation of  $\sigma$  is to apply a probabilistic map  $\mathcal{M}_\sigma : (c', c'') \mapsto (b', b'', p', p'')$ . Because  $S$  must output  $c_A = c_B = c$  while  $S_B \sigma S_A$  might output  $c_A \neq c_B$ , a distinguisher  $\mathcal{D}_0$  which only checks if  $c_A = c_B$  to distinguish  $S$  and  $S_B \sigma S_A$  will provide a lower bound to the distinguishing advantage. That is,  $\mathcal{D}_0(\cdot)$  outputs 1 if  $c_A = c_B$  and else 0. Consider the following map on three cases of the input.

1.  $\Pr[c' = c'' = 0] = z^2$  or  $\Pr[c' = c'' = 1] = (1 - z)^2$ . Because the bits are already the same, the box  $\sigma$  outputs  $p' = 0, b' = c', p'' = 0, b'' = c''$  to keep  $c_A$  and  $c_B$  the same. We have  $c_A = c_B = 0$  or  $c_A = c_B = 1$ .
2.  $\Pr[c' = 0, c'' = 1] = z(1 - z)$ . The box  $\sigma$  outputs  $p' = 1, p'' = 0$  to force the outcome  $c_A = c_B = 1$ . We have  $c_A = c_B = 1$ .
3.  $\Pr[c' = 1, c'' = 0] = z(1 - z)$ . The box  $\sigma$  outputs  $b' = p' = b'' = p'' = 0$  to force the outcome  $c_A = c_B = 0$  with probability  $\frac{\epsilon}{1-z}$ .

This strategy of  $\sigma$  is obviously the optimal one to maximize distinguishing probability under distinguisher  $\mathcal{D}_0$ , which is

$$\Pr[c_A \neq c_B] = \Pr[c_A = 1, c_B = 0] + \Pr[c_A = 0, c_B = 1] = z(1 - z - \epsilon). \quad (17)$$

For any box  $\sigma$ , we have the lower bound on distinguishing advantage:

$$d(S_B \sigma S_A, S) \geq |\Pr[\mathcal{D}_0(S) = 1] - \Pr[\mathcal{D}_0(S_B \sigma S_A) = 1]| \geq z(1 - z - \epsilon). \quad (18)$$

Together with the relation in Equation (16), we have

$$\delta \geq \frac{1}{3}z(1 - z - \epsilon). \quad (19)$$

which shows that  $\pi$  cannot construct  $\mathcal{S}$  with a vanishing distinguishing advantage.  $\square$

By setting  $\epsilon = 0, z = \frac{1}{2}$ , we conclude that there does not exist a protocol  $\pi$  that constructs an ideal balanced unbiased WCF resource  $\mathcal{S}$  with a distinguishing advantage  $\delta < \frac{1}{12}$ .

### 3.2 Impossibility for a general resource

The composable security is defined by comparing between the ideal resource and the actual protocol. Theorem 5 denies the possibility of constructing an actual protocol close to the ideal WCF resource in Definition 4. However, if we modify the definition of the ideal WCF resource into a presumably more complicated one, then there might still exist some protocol that constructs this more complicated resource.

To address this possibility, it is crucial to determine what properties a WCF resource must possess to be useful in general. For a WCF resource  $\mathcal{S} = (S, S_A, S_B)$ , we propose the following conditions:

- **Fully expressing.** A resource  $\mathcal{S}$  for  $\text{WCF}(z, \epsilon)$  is fully expressing if
  1.  $S$  outputs the same value  $c$  at each side subject to distribution:  $\Pr[c = 0] = z, \Pr[c = 1] = 1 - z$ .
  2. For any converter  $\alpha$ , the composition  $\alpha S_A$  outputs bit 0 at the right interface with probability at most  $z + \epsilon$ .
  3. For any converter  $\beta$ , the composition  $S_B \beta$  outputs bit 1 at the left interface with probability at most  $1 - z + \epsilon$ .
- **Simple.** By simplicity of resources, we typically refer to the process of abstracting away specific details of a resource that reduces its overall interaction complexity and allows to study it in a more general context. Here we take the interaction complexity  $\text{Intcom}(S_A), \text{Intcom}(S_B)$  (defined in Section 2.2) to quantify it.

Next, we will show that a fully expressing and simple WCF resource cannot be constructed from noiseless communication channels. Specifically, Theorem 6 states that, if a fully expressing resource for  $\text{WCF}(z, \epsilon)$  with small  $\epsilon$  can be constructed from noiseless communication channels, then its interaction complexity cannot be low.

**Theorem 6.** *Let  $\pi$  be a QCM  $\text{WCF}(\frac{1}{2}, \epsilon)$  protocol, and  $\pi$  constructs a fully expressing resource  $\mathcal{S} = (S, S_A, S_B)$ . Then the interaction complexity of  $\mathcal{S}$  satisfies*

$$\min\{\text{Intcom}(S_A), \text{Intcom}(S_B)\} \geq \exp(\Omega(1/\sqrt{\epsilon})). \quad (20)$$

To prove Theorem 6, we need a proposition rewritten from [40, Theorem 8.2].

**Proposition 7.** *If  $\pi$  is a QCM  $\text{WCF}(\frac{1}{2}, \epsilon)$  protocol, then*

$$\text{Intcom}(\pi) \geq \exp(\Omega(1/\sqrt{\epsilon})). \quad (21)$$

*Proof of Theorem 6.* Without loss of generality, we can assume  $\text{Intcom}(S_B) \leq \text{Intcom}(S_A)$ . Since  $\mathcal{C} \xrightarrow{\pi} \mathcal{S}$ , there exist converters  $\sigma_A, \sigma_B$  such that  $\pi_A \pi_B \approx S$ ,  $\pi_A \approx S_B \sigma_B$ , and  $\pi_B \approx \sigma_A S_A$ . Construct a new protocol  $\pi' = (\pi'_A, \pi'_B)$  with  $\pi'_A = S_B, \pi'_B = \sigma_B \sigma_A S_A$ . Because resource  $\mathcal{S}$  is fully expressing, we conclude that  $\pi'$  is also a  $\text{WCF}(\frac{1}{2}, \epsilon)$  protocol. By Proposition 7,

$$\text{Intcom}(S_B) = \text{Intcom}(\pi') \geq \exp(\Omega(1/\sqrt{\epsilon})). \quad (22)$$

□

Some parts of the argument in the above proof are of more general interest. That is, if there exists a resource  $\mathcal{S}$  that abstracts a two-party protocol  $\pi$ , it implies the existence of another protocol  $\pi'$  with the same interaction complexity as the resource  $\mathcal{S}$ . Furthermore, if the resource reduces the interaction complexity of  $\pi$ , then  $\pi'$  is a better protocol than  $\pi$  in terms of interaction complexity. An example is delegated quantum computation (DQC), where the client aims to delegate computation to the server while maintaining privacy. The  $S_A$  (against dishonest client) of DQC resource [41] abstracting the protocol in [42, 43] has no interaction in either side, because it is just trivial to talk about a dishonest client. This implies the existence of a simple DQC protocol with no interaction, wherein the client performs all the computation herself.

## 4 Security of weak coin flipping under composition

Section 3 highlights the difficulties when formulating the security of WCF in the AC framework. Fortunately, despite these difficulties, there is a prospect of attaining positive outcomes regarding the composability of such protocols. This section starts with the limitation of the stand-alone security definition (Definition 3) in the context of composition. Specifically, for the construction of unbalanced WCF from a balanced one, we propose a condition (Inequality (26)) which, while implicit, is essential in the security proof of the unbalanced WCF protocol depicted in [29]. Subsequently, we introduce global security as an extension of the stand-alone definition to encompass possible interdependencies between the outputs of the WCF protocol and other components in a larger system. Furthermore, we establish the condition under which global security is maintained.

### 4.1 Stand-alone security is not sufficient

For a cryptographic task, some security definitions seem fine from a stand-alone viewpoint but may present some loopholes when composed with other protocols. For example, the accessible information criteria for quantum key distribution falls short of providing composable security due to the data-locking effect[2, 1]. This issue is similar to WCF. In particular, a WCF protocol  $\pi = (\pi_1, \pi_2)$  (where  $\pi_1$  and  $\pi_2$  are used instead of  $\pi_A$  and  $\pi_B$  to avoid confusion in subsequent protocol description) may find its stand-alone security insufficient for the upper-level task.

To illustrate, consider an attacking strategy for an unbalanced WCF protocol  $\mu = (\mu_A, \mu_B)$  constructed from two instances of balanced WCF protocol  $\pi = (\pi_1, \pi_2)$ . The protocol  $\mu$  aims to model the scenario where Alice and Bob are concurrently running two instances of WCF with an undetermined execution order. Assume the protocol  $\pi$  follows the quantum comb model [39, 38] with  $n + 1$  (assume that  $n$  is odd without loss of generality) rounds of communication, where Alice and Bob send messages alternately. Then  $\pi_1$  and  $\pi_2$  can be characterized by the ordered set  $\mathcal{T}_\pi$  shown in Figure 5b, where the subset  $\{t_i\}_{i=0}^n$  is totally ordered. The comb model further requires that

**(R1)** Messages are sent by  $\pi_1$  and accepted by  $\pi_2$  only at  $t_i$  where  $i$  is even.

**(R2)** Messages are sent by  $\pi_2$  and accepted by  $\pi_1$  only at  $t_i$  where  $i$  is odd.

The details of these causal boxes are shown in Appendix A.3.

The protocol  $\mu$  is constructed by connecting two independent instances of  $\pi$  with the converter  $\eta = (\eta_A, \eta_B)$ , as shown in Figure 5a. The converter  $\eta_A$  accepts a classical bit  $c_A$  at position  $t_n$  from  $\pi_1$  and a classical bit  $c'_A$  at position  $t'_b$  from  $\pi'_2$  and outputs  $c''_A$  at position  $t_A$ , where  $c''_A = c_A \wedge c'_A$ .

We demonstrate that the stand-alone security of  $\mu$  can be compromised even if that of  $\pi$  is maintained. As per [29, Lemma 4], if  $\pi$  is a  $\text{WCF}(\frac{1}{2}, \epsilon)$  protocol and  $\epsilon < 1/6$ ,  $\mu$  is expected to be a  $\text{WCF}(\frac{3}{4}, \frac{3}{2}\epsilon)$  protocol. However, this expectation is not met as there exists a strategy for a dishonest Bob to win the game with probability  $\frac{1}{2}$ . Before elaborating on this strategy, we introduce the delay box, denoted by  $\Theta_f$ . This box essentially transforms a message at position  $t$  to a future position  $t'$  according to some delay function  $f$ . For a rigorous definition of delay box, see Appendix A.3.

Consider the parallel composition of delay boxes  $\theta = \theta_1 \parallel \theta_2$  depicted in Figure 6. The delay functions are defined as

$$f_1 : \{t_i \in \mathcal{T}_\pi \mid i \text{ is even}\} \rightarrow \mathcal{T}_{\theta_1}, t_i \mapsto t'_i, \quad (23)$$

$$f_2 : \{t'_i \in \mathcal{T}'_\pi \mid i \text{ is odd}\} \rightarrow \mathcal{T}_{\theta_2}, t'_i \mapsto t_i. \quad (24)$$

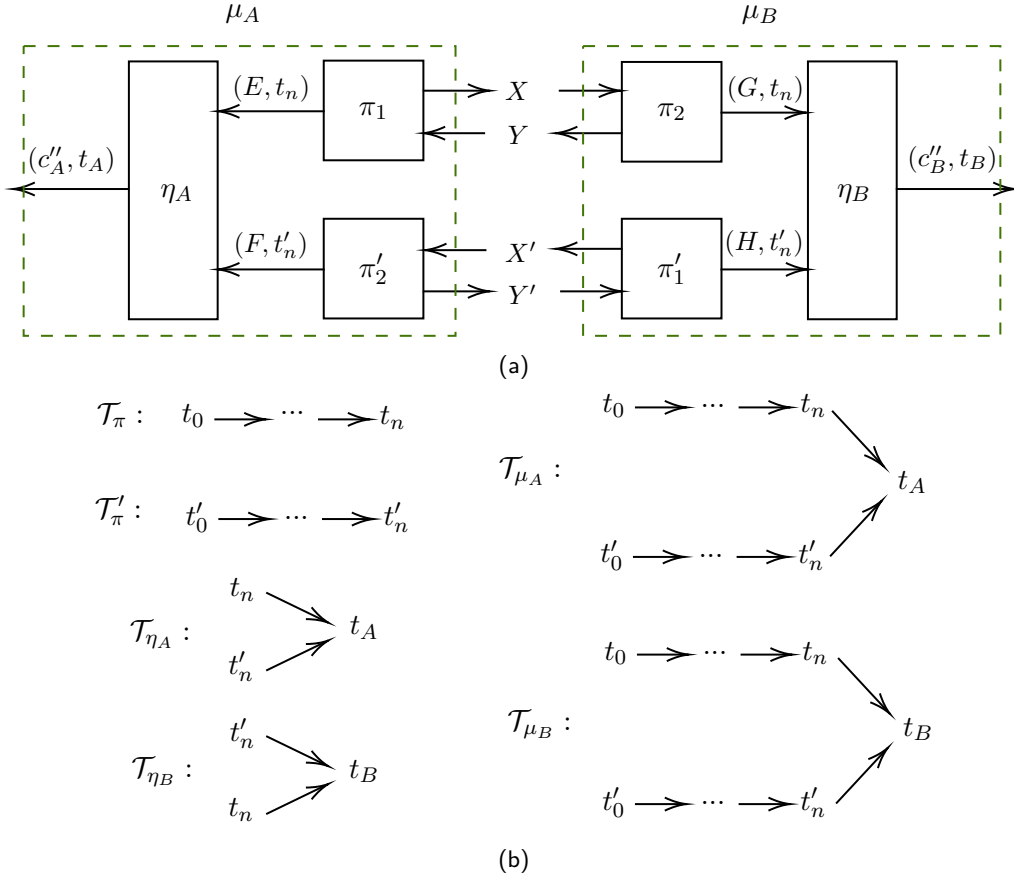

Figure 5: (a) The protocol  $\mu = (\mu_A, \mu_B)$  is constructed from protocol  $\pi$ ,  $\pi'$  and  $\eta$ .  $\eta = (\eta_A, \eta_B)$  is a pair of converters and the two instances  $\pi' = (\pi'_1, \pi'_2)$  and  $\pi = (\pi_1, \pi_2)$  are the same except the ordered sets  $\mathcal{T}'_\pi, \mathcal{T}_\pi$  are independent. (b) This figure shows the Hasse diagram of the posets  $\mathcal{T}_\pi, \mathcal{T}'_\pi, \mathcal{T}_{\eta_A}, \mathcal{T}_{\eta_B}, \mathcal{T}_{\mu_A}, \mathcal{T}_{\mu_B}$ . The Hasse diagram depicts the order relation with directed edge and omits the transitive and reflexive connections for simplicity. The poset  $\mathcal{T}_{\mu_A}$  is obtained by union of  $\mathcal{T}_\pi, \mathcal{T}'_\pi, \mathcal{T}_{\eta_A}$ , which is defined in Definition 17. The poset of  $\mathcal{T}_{\mu_B}$  is obtained similarly.

Proposition 8 shows that Figure 6a emulates a WCF protocol between Alice and herself. See Appendix B.1 for the proof.

**Proposition 8.** *The box  $(\pi_1 \parallel \pi'_2)\theta$  has the same output distribution as  $\pi_1 \pi_2$ .*

Since  $\pi = (\pi_1, \pi_2)$  is a balanced WCF protocol, the distribution of the final output  $c'_A$  is  $P_{c'_A} = (1/2, 1/2)$ , which contradicts our expectation that  $\mu$  is a  $\text{WCF}(\frac{3}{4}, \frac{3}{2}\epsilon)$  protocol.

This example suggests that a stronger criterion is necessary to guarantee the safe composition of WCF protocols. To achieve a  $\text{WCF}(\frac{3}{4}, \frac{3}{2}\epsilon)$  protocol, it is essential that for any box connected to the inner interface of  $\pi_1 \parallel \pi'_2$ , the output satisfies

$$\forall x \in \{0, 1\}, \Pr[c'_A = 1 | c_A = x] \leq \frac{1}{2} + \epsilon. \quad (25)$$

More generally, to construct an unbalanced WCF protocol  $\text{WCF}(z, \epsilon')$  for arbitrary  $z \in [0, \frac{1}{2}]$  with  $n$  instances of protocol  $\pi$ , the following condition is needed:

$$\forall i \in [n], \forall x_1^{i-1} \in \{0, 1\}^{i-1}, \Pr[c_{A,i} = 1 | c_{A,1} = x_1, \dots, c_{A,i-1} = x_{i-1}] \leq \frac{1}{2} + \epsilon, \quad (26)$$

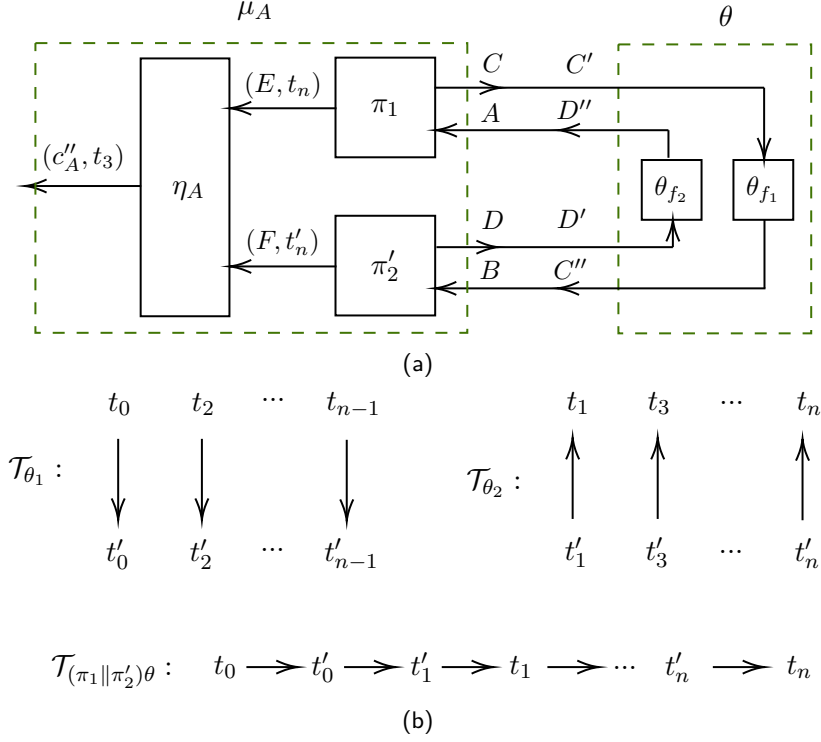

Figure 6: (a) This figure shows the connection of  $\mu_A$  and delay box  $\theta$ . The box  $\theta = \theta_1 \parallel \theta_2$  is a parallel composition of two delay boxes. (b) This figure shows the Hasse diagram of the ordered sets  $\mathcal{T}_{\theta_1}$ ,  $\mathcal{T}_{\theta_2}$  and  $\mathcal{T}_{(\pi_1 \parallel \pi'_2)\theta}$ .

where  $x_1^i = x_1 x_2 \dots x_i$  and the result of the  $i$ th instance is denoted by  $c_{A,i}$ . Notably, inequality (26) is an implicit but crucial condition for the security of unbalanced WCF protocol introduced in [29].

## 4.2 Global security

What is the sufficient condition for Inequality (26) to hold? More broadly speaking, what is the safe way to compose WCF protocols? Despite negative results discussed in Section 3 on the possibility of abstracting WCF as a black-box abstraction, there are still certain ways of composition, satisfying Inequality (26). To explore this, we generalize Inequality (26), introduce the concept of global secrecy and specify the sufficient condition for it.

**Definition 9** (Global security of WCF in a larger system). *Let  $\pi$  be a WCF( $z, \epsilon$ ) protocol and  $\eta$  be a protocol that only outputs classical messages  $K_A, K'_A, K_B, K'_B \in \mathbb{N}$  at its outer interface, where  $K_A, K_B$  are output before  $C_A, C_B$  and  $K'_A, K'_B$  are output after  $C_A, C_B$ . For a new protocol  $\xi = (\xi_A, \xi_B)$  with  $\xi_A = \pi_A \parallel \eta_A, \xi_B = \pi_B \parallel \eta_B$  (denoted by  $\xi = \pi \parallel \eta$ ), the WCF protocol  $\pi$  is said to be globally secure in  $\xi$  if:*

1. For any box  $\alpha$  compatible with the inner interface of  $\xi_A$ :  $\forall k \in \mathbb{N}, \Pr[C_A = 1 | K_A = k] \leq z + \epsilon$ ,
2. For any box  $\beta$  compatible with the inner interface of  $\xi_B$ :  $\forall k \in \mathbb{N}, \Pr[C_B = 0 | K_B = k] \leq 1 - z + \epsilon$ .

The global security defined above is a property of the whole composed system  $\pi \parallel \eta$  rather than the protocol  $\eta$  alone. For some protocols  $\eta$  and  $\eta'$ , a protocol  $\pi$  may be globally secure in  $\pi \parallel \eta$  but not in  $\pi \parallel \eta'$ .

Notably, global security in this definition is much weaker than the universal composability in the AC framework. It is not within any composable framework and only applies to the scenario where the system composed with WCF in parallel takes no input from the outer interface. This assumption is even stricter than the non-interactive assumption in the bounded storage model [24]. Therefore, global security of all components in a larger system only ensures the stand-alone security of the larger system.

The following theorem formulates the intuition that the WCF protocol is not affected by other boxes as long as we forbid any other interaction when the WCF protocol is active.

**Theorem 10.** *Let  $\pi$  be a  $\text{WCF}(z, \epsilon)$  protocol and  $\eta$  be any protocol with only classical output at the outer interface.  $\xi = \pi \parallel \eta$  is their parallel composition with the ordered set  $\mathcal{T}$ . Then  $\pi$  is globally secure in the protocol if there exists a partition  $\mathcal{T}_1, \mathcal{T}_2, \mathcal{T}_3$  of  $\mathcal{T}$  such that*

- (C1)  $\forall t_1 \in \mathcal{T}_1, t_2 \in \mathcal{T}_2, t_3 \in \mathcal{T}_3, t_1 \prec t_2 \prec t_3$ ;
- (C2)  $\eta$  only accepts input and produces output on set  $\mathcal{T}_1 \cup \mathcal{T}_3$ , while  $\pi$  only accepts input and produces output on set  $\mathcal{T}_2$ .

The proof of Theorem 10 is in Appendix B.2. The proof idea is by contradiction. If the adversary can break the global security of the composed protocol, then the adversary can also break the stand-alone security of the WCF protocol, which contradicts the fact and thus completes the proof. Theorem 10 establishes the sufficient condition that the WCF protocols can be composed while maintaining the overall stand-alone security.

For more complicated functionalities, it is usually easy to construct asymmetric imperfect protocols in which one party can cheat more than the other party. Unbalanced WCF protocols make it possible for two parties to fairly choose one of these asymmetric imperfect protocols at random. This results in a less asymmetric imperfect protocol. Therefore, unbalanced WCF protocols play a key role in constructing optimal protocols of more complicated functionalities such as SCF and BC [29, 28]. An unbalanced  $\text{WCF}(z, \epsilon')$  protocol can be constructed from balanced  $\text{WCF}(\frac{1}{2}, \epsilon)$  protocols where  $z = 0.b_1b_2\dots b_n$  is in binary representation, as is shown in Figure 7.

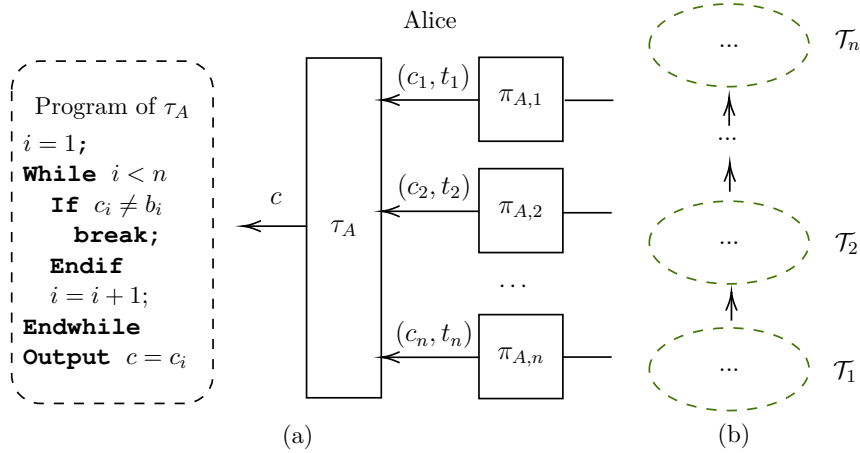

Figure 7: (a) This figure shows Alice part of the unbalanced WCF protocol  $\eta_A = \tau_A(\pi_{A,1} \parallel \dots \parallel \pi_{A,n})$  constructed from balanced protocols  $\pi$ . It runs  $n$  instances of  $\pi_A$  and processes their result in  $\tau_A$ . The program of  $\tau_A$  is presented in the dashed box. Bob's part works similarly. (b) This figure shows the form of the Hasse diagram of  $\eta_A$ , where  $\mathcal{T}_i$  is the posets for instance  $\pi_{A,i}$ . The instances of  $\pi_A$  run in a time-sequential way.

As an example, we apply Theorem 10 to this construction to prove the stand-alone security of the unbalanced WCF protocol in Corollary 11. The idea is to prove the stand-alone security of  $\tau_i(\pi_1 \parallel \dots \parallel \pi_i)$  constructed from  $\tau_{i-1}(\pi_1 \parallel \dots \parallel \pi_{i-1})$  and  $\pi_i$  using Theorem 10 recursively. The detailed proof can be found in Appendix B.3.

**Corollary 11.** *Let  $z \in [0, \frac{1}{2}]$ . The unbalanced WCF protocol shown in Figure 7 is a WCF( $z, \epsilon'$ ) protocol with  $\epsilon' = 2\epsilon + o(\epsilon)$ .*

## 5 Acknowledgement

We thank Christopher Portmann and Vilasini Venkatesh for useful discussions. This research was initiated while AB was hosted at CQT. This research is supported by the National Research Foundation, Singapore and A\*STAR under its CQT Bridging Grant and its Quantum Engineering Programme (NRF2021-QEP2-01-P06). AB acknowledges the partial support provided by Commonwealth Cyber Initiative (CCI-SWVA) under the 2023 Cyber Innovation Scholars Program.

## A Causal box model

In this appendix, we introduce necessary concepts related to the causal box model. Part of this section is from [35].

### A.1 Causal box

Let  $\mathcal{T}$  be a partially ordered set (poset). That is,  $\mathcal{T}$  is a set equipped with a binary relation  $\preceq$  that is reflexive, antisymmetric and transitive. For  $x, y \in \mathcal{T}$ ,  $x \prec y$  if  $x \preceq y$  and  $x \neq y$ . Denote  $\mathcal{T}^{\preceq t} = \{x \in \mathcal{T} \mid x \preceq t\}$ .

**Definition 12** (Cuts). *A subset  $\mathcal{C}$  of poset  $\mathcal{T}$  is a cut if it takes the form*

$$\mathcal{C} = \bigcup_{t \in \mathcal{C}} \mathcal{T}^{\preceq t}. \quad (27)$$

*A cut is bounded if  $\exists t \in \mathcal{T}, \mathcal{C} \subseteq \mathcal{T}^{\preceq t}$ . The set of all cuts of  $\mathcal{T}$  is denoted by  $\mathfrak{C}(\mathcal{T})$ . The set of all bounded cuts of  $\mathcal{T}$  is denoted by  $\bar{\mathfrak{C}}(\mathcal{T})$ .*

**Lemma 13** (An equivalent condition for cut). *A subset  $\mathcal{C}$  of a poset  $\mathcal{T}$  is a cut if and only if  $t \in \mathcal{C} \Rightarrow \forall x \preceq t, x \in \mathcal{C}$ .*

*Proof.* If  $\mathcal{C}$  is a cut, for  $t \in \mathcal{C}$  and  $x \preceq t$ , we have  $x \in \mathcal{T}^{\preceq t}$ , thus  $x \in \mathcal{C}$ . If  $\forall t \in \mathcal{C}, \forall x \preceq t, x \in \mathcal{C}$ , then  $\forall x \in \mathcal{T}^{\preceq t}, x \in \mathcal{C}$ . We have  $\forall t \in \mathcal{C}, \mathcal{T}^{\preceq t} \subseteq \mathcal{C}$ , thus  $\mathcal{C} = \bigcup_{t \in \mathcal{C}} \mathcal{T}^{\preceq t}$ .  $\square$

**Definition 14** (Causality function). *A function  $\chi : \mathfrak{C}(\mathcal{T}) \rightarrow \mathfrak{C}(\mathcal{T})$  is a causality function if:*

$$\forall \mathcal{C}, \mathcal{D} \in \mathfrak{C}(\mathcal{T}), \quad \chi(\mathcal{C} \cup \mathcal{D}) = \chi(\mathcal{C}) \cup \chi(\mathcal{D}), \quad (28)$$

$$\forall \mathcal{C}, \mathcal{D} \in \mathfrak{C}(\mathcal{T}), \quad \mathcal{C} \subseteq \mathcal{D} \implies \chi(\mathcal{C}) \subseteq \chi(\mathcal{D}), \quad (29)$$

$$\forall \mathcal{C} \in \bar{\mathfrak{C}}(\mathcal{T}) \setminus \{\emptyset\}, \quad \chi(\mathcal{C}) \subsetneq \mathcal{C}, \quad (30)$$

$$\forall \mathcal{C} \in \bar{\mathfrak{C}}(\mathcal{T}), \forall t \in \mathcal{C}, \exists n \in \mathbb{N}, \quad t \notin \chi^n(\mathcal{C}), \quad (31)$$

Using cuts and causality function, we can formally define causal box.

**Definition 15** (Causal box). *A causal box is a system with input wire  $X$  and output wire  $Y$ , defined as a set of CPTP maps:*

$$\Phi := \{\Phi^{\mathcal{C}} : \mathfrak{T}(\mathcal{F}_X^{\mathcal{T}}) \rightarrow \mathfrak{T}(\mathcal{F}_Y^{\mathcal{C}})\}_{\mathcal{C} \in \bar{\mathfrak{C}}(\mathcal{T})}, \quad (32)$$

where  $\mathfrak{T}(\mathcal{H})$  denotes the set of all trace class operators on the Hilbert space  $\mathcal{H}$ . These maps must be mutually consistent

$$\forall \mathcal{C}, \mathcal{D} \in \bar{\mathfrak{C}}(\mathcal{T}), \mathcal{C} \subseteq \mathcal{D} : \Phi^{\mathcal{C}} = \text{tr}_{\mathcal{D} \setminus \mathcal{C}} \circ \Phi^{\mathcal{D}} \quad (33)$$

and respect causality, i.e., there exists a causality function  $\chi : \mathfrak{C}(\mathcal{T}) \rightarrow \mathfrak{C}(\mathcal{T})$  such that

$$\Phi^{\mathcal{C}} = \Phi^{\chi(\mathcal{C})} \circ \text{tr}_{\mathcal{T} \setminus \chi(\mathcal{C})}. \quad (34)$$

Alternatively, the causal box  $\Phi$  can be described in Choi-Jamiołkowski (CJ) representation. To be precise, the Choi operator  $R_{\Phi}^{\mathcal{C}}$  for the CPTP map  $\Phi^{\mathcal{C}}$  is a sesquilinear semi-definite form on  $\mathcal{F}_Y^{\mathcal{C}} \otimes \mathcal{F}_X^{\chi(\mathcal{C})}$  such that

$$R_{\Phi}^{\mathcal{C}}(\psi_Y \otimes \psi_X, \varphi_Y \otimes \varphi_X) = \langle \psi_Y | \Phi^{\mathcal{C}}(|\bar{\psi}_X\rangle\langle\bar{\varphi}_X|) | \varphi_Y \rangle. \quad (35)$$

where  $|\bar{\psi}\rangle = \sum_i |i\rangle\langle\psi|i\rangle$  for a fixed basis  $\{|i\rangle\}_i$ .

## A.2 Connection of causal boxes

Causal boxes can be connected by parallel composition and loop.

**Definition 16** (Parallel composition of causal box). *Let  $\Phi = \{\Phi^{\mathcal{C}}\}_{\mathcal{C} \in \bar{\mathfrak{C}}(\mathcal{T})}$  and  $\Psi = \{\Psi^{\mathcal{C}}\}_{\mathcal{C} \in \bar{\mathfrak{C}}(\mathcal{T})}$  be two causal boxes. The parallel composition of them, denoted by  $\Phi \parallel \Psi$  is defined as*

$$\Gamma := \{\Phi^{\mathcal{C}} \otimes \Psi^{\mathcal{C}}\}. \quad (36)$$

The above definition of parallel composition implicitly requires the causal boxes  $\Phi$  and  $\Psi$  share the same partially ordered set  $\mathcal{T}$ . However, a general causal box may not contain the information of the causal structure of some other causal box, that is, there is no such common set  $\mathcal{T}$ . In this case, to make the composition possible, we propose a more general version of parallel composition. Before that, we introduce the union of posets that might have intersection.

A poset  $\mathcal{T}$  can be treated as a tuple of a set and a partial order relation  $\mathcal{T} = (\mathfrak{S}, \preceq)$ . We define the union of two posets as follows.

**Definition 17** (Union of partial orders). *Let  $\mathcal{T}_1 = (\mathfrak{S}_1, \preceq_1)$  and  $\mathcal{T}_2 = (\mathfrak{S}_2, \preceq_2)$  be two compatible posets. Let the relation on the set  $\mathfrak{S} = \mathfrak{S}_1 \cup \mathfrak{S}_2$  be  $\preceq = \preceq_1 \sqcup \preceq_2$ . Then  $x \preceq y$  if and only if there exists a sequence  $\{a_i\}_{i=0}^n \subseteq \mathfrak{S}_1 \sqcup \mathfrak{S}_2$  such that  $a_1 = x$ ,  $a_n = y$  and  $\forall i \in [n]$  either  $a_{i-1} \preceq_1 a_i$  or  $a_{i-1} \preceq_2 a_i$ . The union of posets, denoted by  $\mathcal{T}_1 \sqcup \mathcal{T}_2$ , is then defined as*

$$\mathcal{T}_1 \sqcup \mathcal{T}_2 := (\mathfrak{S}_1 \cup \mathfrak{S}_2, \preceq_1 \sqcup \preceq_2) = (\mathfrak{S}, \preceq) \quad (37)$$

In the above definition,  $\mathcal{T}_1$  and  $\mathcal{T}_2$  are said to be compatible if  $\preceq_1 \sqcup \preceq_2$  is still a partial order.

After introducing the union of posets, we are ready to define the parallel composition of two causal boxes with compatible posets.



**Definition 18** (Parallel composition of causal boxes with arbitrary compatible ordered sets).  $\Phi = \{\Phi^C\}_{C \in \bar{\mathcal{C}}(\mathcal{T}_1)}$  and  $\Psi = \{\Psi^C\}_{C \in \bar{\mathcal{C}}(\mathcal{T}_2)}$  are causal boxes defined on compatible partially ordered set  $\mathcal{T}_1$  and  $\mathcal{T}_2$  respectively, which can have arbitrary intersection.  $\Phi$  has input wire  $X_1$  and output wire  $Y_1$ .  $\Psi$  has input wire  $X_2$  and output wire  $Y_2$ . The parallel composition of  $\Phi$  and  $\Psi$ , denoted by  $\Gamma = \Phi \parallel \Psi$ , is defined on the new poset  $\mathcal{T} = \mathcal{T}_1 \sqcup \mathcal{T}_2$  as

$$\Gamma := \{\Gamma^C\}_{C \in \bar{\mathcal{C}}(\mathcal{T})}, \quad (38)$$

$$\Gamma^C := \Phi^{C_1} \otimes \Psi^{C_2} \circ \text{tr}_{\mathcal{F}_{X_1}^{\mathcal{T} \setminus \mathcal{T}_1} \otimes \mathcal{F}_{X_2}^{\mathcal{T} \setminus \mathcal{T}_2}}, \quad (39)$$

where  $C_1 = \mathcal{T}_1 \cap C$ ,  $C_2 = \mathcal{T}_2 \cap C$ .

Lemma 19, 20 and 21 suggest that Definition 18 is well defined.

**Lemma 19.** For compatible posets  $\mathcal{T}_1$  and  $\mathcal{T}_2$ , if  $\mathcal{C}$  is a cut in  $\mathcal{T}_1 \sqcup \mathcal{T}_2$ , then  $C_1 = \mathcal{C} \cap \mathcal{T}_1$  and  $C_2 = \mathcal{C} \cap \mathcal{T}_2$  are cuts in  $\mathcal{T}_1$  and  $\mathcal{T}_2$  respectively.

*Proof.* Notice that

$$C_1 = \mathcal{C} \cap \mathcal{T}_1 = \bigcup_{t \in \mathcal{C}} (\mathcal{T}^{\preceq t} \cap \mathcal{T}_1).$$

Assume  $t' \in \mathcal{T}^{\preceq t} \cap \mathcal{T}_1$ , then by Definition 17,  $\forall x \in \mathcal{T}_1, x \preceq_1 t' \Rightarrow x \preceq t \Rightarrow x \in \mathcal{T}^{\preceq t} \cap \mathcal{T}_1$ . According to Lemma 13,  $\mathcal{T}^{\preceq t} \cap \mathcal{T}_1$  is a cut in  $\mathcal{T}_1$ . As the union of cuts,  $C_1$  is also a cut. The same argument follows for  $C_2$ .  $\square$

**Lemma 20** (Existence of causality function). Let  $\Gamma = \Phi \parallel \Psi$  with the poset  $\mathcal{T} = \mathcal{T}_1 \sqcup \mathcal{T}_2$  be the parallel composition of causal boxes  $\Phi$  and  $\Psi$  with compatible posets  $\mathcal{T}_1$  and  $\mathcal{T}_2$ . There exists a causality function  $\chi$  on  $\mathcal{C}(\mathcal{T})$  such that:

$$\Gamma^C = \Gamma^C \circ \text{tr}_{\mathcal{F}_{X_1 \oplus X_2}^{\chi(C)}} \quad (40)$$

*Proof.* Assume  $\chi_1$  and  $\chi_2$  are causality functions for  $\Phi$  and  $\Psi$ , respectively. Construct the function  $\chi : \mathcal{C}(\mathcal{T}) \rightarrow \mathcal{C}(\mathcal{T})$  such that  $\chi(C) = \chi_1(C \cap \mathcal{T}_1) \cup \chi_2(C \cap \mathcal{T}_2)$ , then it is easy to verify the conditions in Definition 14.  $\square$

**Lemma 21** (Associativity). For boxes  $\Phi, \Psi, \Theta$  with compatible posets  $\mathcal{T}_\Phi, \mathcal{T}_\Psi, \mathcal{T}_\Theta$ ,

$$(\Phi \parallel \Psi) \parallel \Theta = \Phi \parallel (\Psi \parallel \Theta). \quad (41)$$

*Proof.* This lemma follows directly from Definition 18.  $\square$

**Definition 22** (Loop). Let  $\Phi = \{\Phi^C : \mathfrak{I}(\mathcal{F}_{AB}^T) \rightarrow \mathfrak{I}(\mathcal{F}_{CD}^C)\}_{C \in \bar{\mathcal{C}}(\mathcal{T})}$  be a causal box such that  $\dim \mathcal{H}_B = \dim \mathcal{H}_C$  is its CJ representation. Let  $\{|k_C\rangle\}$  and  $\{|l_C\rangle\}$  be any orthonormal bases of  $\mathcal{F}_C^C$  and  $\{|k_B\rangle\}$  and  $\{|l_B\rangle\}$  be corresponding bases of  $\mathcal{F}_C^C$ . The new box by looping from wire B to wire C, denoted by  $\Psi = \Phi^{C \hookrightarrow B}$ , is a set of maps  $\{\Psi^C : \mathfrak{I}(\mathcal{F}_A^T) \rightarrow \mathfrak{I}(\mathcal{F}_D^C)\}$  with CJ representation

$$R_\Psi^C(\psi_D \otimes \psi_A, \varphi_D \otimes \varphi_A) \quad (42)$$

$$= \sum_{k,l} R_\Phi^C(k_C \otimes \psi_D \otimes \psi_A \otimes \bar{k}_B, l_C \otimes \varphi_D \otimes \varphi_A \otimes \bar{l}_B), \quad (43)$$

where the conjugate  $|\bar{\psi}\rangle = \sum_i |i_B\rangle \langle \psi | i_B\rangle$  is taken with respect to the base  $|i_B\rangle$  of  $\mathcal{F}_B^T$  on which the CJ representation is defined.

### A.3 Delay box

**Definition 23** (Delay function). Let  $\mathcal{T}$  be a poset and  $\mathcal{G} = \{t \in \mathcal{T} \mid \exists t' \in \mathcal{T}, t \prec t'\}$  is a subset of  $\mathcal{T}$ . A function  $f : \mathcal{G} \rightarrow \mathcal{T}$  is a delay function on  $\mathcal{T}$  if for any  $t \in \mathcal{G}$ ,  $t \prec f(t)$ .

**Proposition 24.** If  $\mathcal{T}$  is a finite set, a delay function  $f$  on  $\mathcal{T}$  induces a causality function

$$\chi_f(\mathcal{C}) = \bigcup_{t:f(t) \in \mathcal{C}} \mathcal{T}^{\leq t}. \quad (44)$$

It is easy to verify  $\chi_f$  is a causality function by definition.

**Definition 25** (Delay box). A delay box derived from a delay function  $f : \mathcal{G} \rightarrow \mathcal{T}$  with input wire  $X$  and output wire  $X'$  is denoted by  $\Theta_f = \{\Theta_f^{\mathcal{C}} : \mathfrak{T}(\mathcal{F}_X^{\chi_f(\mathcal{C})}) \rightarrow \mathfrak{T}(\mathcal{F}_{X'}^{\mathcal{C}})\}_{\mathcal{C} \in \bar{\mathcal{C}}(\mathcal{T})}$ .  $\mathcal{H}_X$  and  $\mathcal{H}_{X'}$  are of the same dimension.  $\Theta_f^{\mathcal{C}}$  is defined as the following isometry:

$$U_f^{\mathcal{C}} = \bigoplus_{n=0}^{\infty} \left( \sum_{i \in I} |i\rangle_{X'} \langle i|_X \otimes \sum_{t \in \chi_f(\mathcal{C})} |f(t)\rangle \langle t| \right)^{\otimes n}, \quad (45)$$

for some bases  $\{|i\rangle_X\}_{i \in I}$  and  $\{|i\rangle_{X'}\}_{i \in I}$  of spaces  $\mathcal{H}_X$  and  $\mathcal{H}_{X'}$ .

$\theta_1$  is a delay box from input wire  $C'$  to output wire  $C''$  and is derived from  $f_1$  defined in Equation 23. Then,  $U_{f_1}^{\mathcal{C}}$  is an isometry between  $\mathcal{F}_{C'}^{\chi_{f_1}(\mathcal{C})}$  and  $\mathcal{F}_{C''}^{\mathcal{C} \cap \mathcal{T}_{\pi'}}$

## B Proofs

### B.1 Proof of Proposition 8

Since the protocol  $\pi$  is restricted to the comb model, we can assume that  $\pi_1$  only outputs at the set  $\mathcal{T}_{\pi}^{\text{even}} = \{t_i \in \mathcal{T}_{\pi} \mid i \text{ is even}\}$  and  $\pi_2$  only outputs at set  $\mathcal{T}_{\pi}^{\text{odd}} = \{t_i \in \mathcal{T}_{\pi} \mid i \text{ is odd}\}$ .

For simplicity, where the cut  $\mathcal{C}$  is obvious, denote for  $X = B, C, C', C'', E$

$$\hat{X} = \mathcal{F}_X^{\mathcal{C} \cap \mathcal{T}_{\pi}^{\text{even}}}, \quad (46)$$

$$\tilde{X} = \mathcal{F}_X^{\mathcal{C} \cap \mathcal{T}_{\pi'}^{\text{even}}}, \quad (47)$$

where  $\mathcal{T}_{\pi}$  is the poset for  $\pi = (\pi_1, \pi_2)$  and  $\mathcal{T}_{\pi'}$  is the partial order for  $\pi' = (\pi'_2, \pi'_1)$ . And denote the wire space of  $X = A, D, D', D'', F$  by

$$\hat{X} = \mathcal{F}_X^{\mathcal{C} \cap \mathcal{T}_{\pi}^{\text{odd}}}, \quad (48)$$

$$\tilde{X} = \mathcal{F}_X^{\mathcal{C} \cap \mathcal{T}_{\pi'}^{\text{odd}}}. \quad (49)$$

For  $\mathcal{C} \in \mathcal{C}(\mathcal{T}_{\pi})$ ,  $\{|i\rangle_{\hat{A}}\}$  is a orthonormal base of space  $\mathcal{F}_A^{\chi_{\pi}(\mathcal{C})}$ , The Choi-Jamiolkowski (CJ) representation of the box  $\pi_1$  is a sesquilinear form  $R_{\pi_1}^{\mathcal{C}}$  satisfying

$$R_{\pi_1}^{\mathcal{C}}(\psi_{\hat{C}} \otimes \psi_{\hat{E}} \otimes \psi_{\hat{A}}, \varphi_{\hat{C}} \otimes \varphi_{\hat{E}} \otimes \varphi_{\hat{A}}) = \langle \psi_{\hat{C}} | \langle \psi_{\hat{E}} | \Pi_1^{\mathcal{C}}(|\bar{\psi}_{\hat{A}}\rangle \langle \bar{\varphi}_{\hat{A}}|) |\varphi_{\hat{E}}\rangle |\varphi_{\hat{C}}\rangle, \quad (50)$$

where  $\Pi_1^{\mathcal{C}}$  is the CPTP map for box  $\pi_1$  on cut  $\mathcal{C}$  and the conjugate of  $\bar{\psi}_{\hat{A}}, \bar{\varphi}_{\hat{A}}$  is taken on basis  $\{|i\rangle_{\hat{A}}\}$ . We only care about the effect of  $R_{\pi_1}^{\mathcal{C}}$  on space  $\hat{A}, \hat{C}, \hat{E}$  because of the conditions **(R1)**, **(R2)** required by the comb model.

For  $\mathcal{C} \in \mathcal{T}_{\pi}$ , assume that the wire  $B, C$  are connected with respect to the bases  $\{|k_{\hat{C}}\rangle\}, \{|l_{\hat{C}}\rangle\}$  of  $\hat{C}$  and the bases  $\{|k_{\hat{B}}\rangle\}, \{|l_{\hat{B}}\rangle\}$  of  $\hat{B}$ , the wire  $D, A$  are connected with

respect to the orthonormal bases  $\{|p_{\hat{D}}\rangle\}$ ,  $\{|q_{\hat{D}}\rangle\}$  of  $\hat{D}$  and the orthonormal bases  $\{|p_{\hat{A}}\rangle\}$ ,  $\{|q_{\hat{A}}\rangle\}$  of  $\hat{A}$ . The CJ representation of  $\pi_1\pi_2$  is

$$\begin{aligned} & R_{\pi_1\pi_2}^{\mathcal{C}}(\psi_{\hat{E}} \otimes \psi_{\hat{F}}, \varphi_{\hat{E}} \otimes \varphi_{\hat{F}}) \\ &= \sum_{k,l,p,q} R_{\pi_1}^{\mathcal{C}}(k_{\hat{C}} \otimes \psi_{\hat{E}} \otimes \bar{p}_A, l_{\hat{C}} \otimes \varphi_{\hat{E}} \otimes \bar{q}_{\hat{A}}) R_{\pi_2}^{\mathcal{C}}(p_{\hat{D}} \otimes \psi_{\hat{F}} \otimes \bar{k}_{\hat{B}}, q_{\hat{D}} \otimes \varphi_{\hat{F}} \otimes \bar{l}_{\hat{B}}) \end{aligned} \quad (51)$$

For  $\mathcal{C}' \in \mathfrak{C}(\mathcal{T}_{\theta_1})$ ,  $\{|i\rangle_{\hat{C}'}\}$  is a base of space  $\mathcal{F}_{\mathcal{C}'}^{\chi_{\theta_1}(\mathcal{C}'})}$ , and  $\{|i\rangle_{\hat{C}''}\}$  is a base of space  $\mathcal{F}_{\mathcal{C}''}^{f_1(\chi_{\theta_1}(\mathcal{C}'))}$  such that  $U_{f_1}|i\rangle_{\hat{C}'} = |i\rangle_{\hat{C}''}$ <sup>1</sup>. The CJ representation of the delay box  $\theta_1$  is

$$\begin{aligned} & R_{\theta_1}^{\mathcal{C}'}(\psi_{\hat{C}''} \otimes \psi_{\hat{C}''} \otimes \alpha_{\hat{C}'}, \varphi_{\hat{C}''} \otimes \varphi_{\hat{C}''} \otimes \beta_{\hat{C}'}) \\ &= \langle \psi_{\hat{C}''} | \Theta_1^{\mathcal{C}'} (|\bar{\alpha}_{\hat{C}'}\rangle \langle \bar{\beta}_{\hat{C}'}|) | \varphi_{\hat{C}''} \rangle \cdot \langle \psi_{\hat{C}''} | \Omega_{\hat{C}''} \rangle \langle \Omega_{\hat{C}''} | \varphi_{\hat{C}''} \rangle \\ &= \langle \psi_{\hat{C}''} | \bar{\alpha}_{\hat{C}''} \rangle \langle \bar{\beta}_{\hat{C}''} | \varphi_{\hat{C}''} \rangle \cdot \langle \psi_{\hat{C}''} | \Omega_{\hat{C}''} \rangle \langle \Omega_{\hat{C}''} | \varphi_{\hat{C}''} \rangle, \end{aligned} \quad (52)$$

where  $\bar{\alpha}_{\hat{C}''} \in \mathcal{F}_{\hat{C}''}^{\mathcal{C}'}$  and  $\bar{\beta}_{\hat{C}''} \in \mathcal{F}_{\hat{C}''}^{\chi(\mathcal{C}'})$  have the same coefficients in the bases of  $\{|i\rangle_{\hat{C}''}\}$  and  $\{|i\rangle_{\hat{C}'}\}$ . Since the state on space  $\hat{C}''$  is always a vacuum state, we omit the arguments  $\psi_{\hat{C}''}, \varphi_{\hat{C}''}$  of  $R_{\theta_1}^{\mathcal{C}'}$  and the second term of Equation (52) in the remaining part of the paper.

For all  $\mathcal{C} \in \mathfrak{C}(\mathcal{T}_{\pi_1\theta_1})$ , wire  $C$  and  $C'$  are connected with respect the bases  $\{|k_{\hat{C}'}\rangle\}$  and  $\{|l_{\hat{C}'}\rangle\}$  such that  $|k_{\hat{C}'}\rangle \cong |k_{\hat{C}}\rangle, |l_{\hat{C}'}\rangle \cong |l_{\hat{C}}\rangle$ . the CJ representation of the composition box  $\bar{\pi}_1 = \pi_1\theta_1$  is,

$$\begin{aligned} & R_{\bar{\pi}_1}^{\mathcal{C}}(\gamma_{\hat{C}''} \otimes \psi_{\hat{E}} \otimes \psi_{\hat{A}}, \eta_{\hat{C}''} \otimes \varphi_{\hat{E}} \otimes \varphi_{\hat{A}}) \\ &= \sum_{k,l} R_{\pi_1}^{\mathcal{C}_1}(k_{\hat{C}} \otimes \psi_{\hat{E}} \otimes \psi_{\hat{A}}, l_{\hat{C}} \otimes \varphi_{\hat{E}} \otimes \varphi_{\hat{A}}) R_{\theta_1}^{\mathcal{C}_2}(\gamma_{\hat{C}''} \otimes \bar{k}_{\hat{C}'}, \eta_{\hat{C}''} \otimes \bar{l}_{\hat{C}'}) \end{aligned} \quad (53)$$

$$= \sum_{k,l} R_{\pi_1}^{\mathcal{C}_1}(k_{\hat{C}} \otimes \psi_{\hat{E}} \otimes \psi_{\hat{A}}, l_{\hat{C}} \otimes \varphi_{\hat{E}} \otimes \varphi_{\hat{A}}) \langle \gamma_{\hat{C}''} | k_{\hat{C}''} \rangle \langle l_{\hat{C}''} | \eta_{\hat{C}''} \rangle \quad (54)$$

$$= R_{\pi_1}^{\mathcal{C}_1} \left( \sum_k \langle k_{\hat{C}''} | \gamma_{\hat{C}''} \rangle k_{\hat{C}} \otimes \psi_{\hat{E}} \otimes \psi_{\hat{A}}, \sum_l \langle l_{\hat{C}''} | \eta_{\hat{C}''} \rangle l_{\hat{C}} \otimes \varphi_{\hat{E}} \otimes \varphi_{\hat{A}} \right) \quad (55)$$

$$= R_{\pi_1}^{\mathcal{C}_1}(\gamma_{\hat{C}} \otimes \psi_{\hat{E}} \otimes \psi_{\hat{A}}, \eta_{\hat{C}} \otimes \varphi_{\hat{E}} \otimes \varphi_{\hat{A}}), \quad (56)$$

where  $|\gamma_{\hat{C}}\rangle = (\sum_k |k_{\hat{C}}\rangle \langle k_{\hat{C}''}|) |\gamma_{\hat{C}''}\rangle$  and  $|\eta_{\hat{C}}\rangle = (\sum_l |l_{\hat{C}}\rangle \langle l_{\hat{C}''}|) |\eta_{\hat{C}''}\rangle$ . Equation (53) follows from Definition 18, Equation (54) follows from Equation (52) and Equation (55) follows from the sesquilinearity.

Similarly, for all  $\mathcal{C} \in \mathfrak{C}(\mathcal{T}_{\pi_2'\theta_2})$ , wire  $D$  and  $D'$  are connected with respect the bases  $\{|p_{\hat{D}'}\rangle\}$  and  $\{|q_{\hat{D}'}\rangle\}$  such that  $|p_{\hat{D}'}\rangle \cong |p_{\hat{D}}\rangle, |q_{\hat{D}'}\rangle \cong |q_{\hat{D}}\rangle$ . The CJ representation of the box  $\bar{\pi}_2' = \pi_2'\theta_2$  is

$$R_{\bar{\pi}_2'}^{\mathcal{C}}(\lambda_{\hat{D}''} \otimes \psi_{\hat{F}} \otimes \psi_{\hat{B}}, \omega_{\hat{D}''} \otimes \varphi_{\hat{F}} \otimes \varphi_{\hat{B}}) \quad (57)$$

$$= R_{\pi_2'}^{\mathcal{C}_1}(\lambda_{\hat{D}} \otimes \psi_{\hat{F}} \otimes \psi_{\hat{B}}, \omega_{\hat{D}} \otimes \varphi_{\hat{F}} \otimes \varphi_{\hat{B}}), \quad (58)$$

where  $|\lambda_{\hat{D}}\rangle = (\sum_p |p_{\hat{D}}\rangle \langle p_{\hat{D}''}|) |\lambda_{\hat{D}''}\rangle$  and  $|\omega_{\hat{D}}\rangle = (\sum_q |q_{\hat{D}}\rangle \langle q_{\hat{D}''}|) |\omega_{\hat{D}''}\rangle$ .

<sup>1</sup>This is possible because  $\mathcal{F}_{\mathcal{C}'}^{\chi_{\theta_1}(\mathcal{C}'})} \simeq \mathcal{F}_{\mathcal{C}''}^{f_1(\chi_{\theta_1}(\mathcal{C}'))}$ .

Notice that, for all  $\mathcal{C} \in \bar{\mathcal{C}}(\mathcal{T}_{(\pi_1 \parallel \pi'_2)})$ , we have the relation chain of the base vectors

$$\begin{aligned}
|k_{\hat{B}}\rangle &\cong |k_{\hat{B}}\rangle \cong |k_{\hat{C}}\rangle \cong |k_{\hat{C}'}\rangle \cong |k_{\hat{C}''}\rangle, \\
|l_{\hat{B}}\rangle &\cong |l_{\hat{B}}\rangle \cong |l_{\hat{C}}\rangle \cong |l_{\hat{C}'}\rangle \cong |l_{\hat{C}''}\rangle, \\
|p_{\hat{A}}\rangle &\cong |p_{\hat{A}}\rangle \cong |p_{\hat{D}}\rangle \cong |p_{\hat{D}'}\rangle \cong |p_{\hat{D}''}\rangle, \\
|q_{\hat{A}}\rangle &\cong |q_{\hat{A}}\rangle \cong |q_{\hat{D}}\rangle \cong |q_{\hat{D}'}\rangle \cong |q_{\hat{D}''}\rangle.
\end{aligned} \tag{59}$$

The first column of  $\cong$  follows naturally by simply substituting  $t_i \in \mathcal{T}_\pi$  with  $t'_i \in \mathcal{T}_{\pi'}$ . The second column is defined by the connection of  $\pi_1, \pi_2$ . The third column is defined by the connection inside  $\bar{\pi}_1$  and  $\bar{\pi}'_2$ . The fourth column follows from the effect of delay boxes  $\theta_1$  and  $\theta_2$ .

Then for  $\mathcal{C} = \mathcal{T}_{(\pi_1 \parallel \pi'_2)\theta}$ , we choose the bases  $\{|k\rangle_{\hat{C}''}\}, \{|l\rangle_{\hat{C}''}\}, \{|k\rangle_{\hat{B}}\}, \{|l\rangle_{\hat{B}}\}$  for the connection of  $C'', B$  and the bases  $\{|p_{\hat{D}''}\}\}, \{|q_{\hat{D}''}\}\}, \{|p_{\hat{A}}\}\}, \{|q_{\hat{A}}\}\}$  for the connection of  $D'', A$ . The CJ representation of the final box  $\bar{\pi}_1 \bar{\pi}'_2$  is

$$R_{\bar{\pi}_1 \bar{\pi}'_2}^{\mathcal{T}_{(\pi_1 \parallel \pi_2)\theta}}(\psi_{\hat{E}} \otimes \psi_{\hat{F}}, \varphi_{\hat{E}} \otimes \varphi_{\hat{F}}) \tag{60}$$

$$= \sum_{k,l,p,q} R_{\bar{\pi}_1}^{\mathcal{T}_{\pi_1}}(k_{\hat{C}''} \otimes \psi_E \otimes \bar{p}_A, l_{\hat{C}''} \otimes \varphi_{\hat{E}} \otimes \bar{q}_A) R_{\bar{\pi}'_2}^{\mathcal{T}_{\pi'_2}}(p_{\hat{D}''} \otimes \psi_{\hat{F}} \otimes \bar{k}_{\hat{B}}, q_{\hat{D}''} \otimes \varphi_{\hat{F}} \otimes \bar{l}_{\hat{B}}) \tag{61}$$

$$= \sum_{k,l,p,q} R_{\bar{\pi}_1}^{\mathcal{T}_{\pi_1}}(k_{\hat{C}} \otimes \psi_E \otimes \bar{p}_A, l_{\hat{C}} \otimes \varphi_{\hat{E}} \otimes \bar{q}_A) R_{\bar{\pi}'_2}^{\mathcal{T}_{\pi'_2}}(p_{\hat{D}} \otimes \psi_{\hat{F}} \otimes \bar{k}_{\hat{B}}, q_{\hat{D}} \otimes \varphi_{\hat{F}} \otimes \bar{l}_{\hat{B}}). \tag{62}$$

where  $\mathcal{C}'_1 = \mathcal{C} \cap \mathcal{T}_\pi$  and  $\mathcal{C}'_2 = \mathcal{C} \cap \mathcal{T}_{\pi'}$ . Since  $R_{\pi_2}$  and  $R_{\pi'_2}$  have the same effect on their respective spaces, there exist isomorphisms from  $\hat{B}, \hat{F}, \hat{D}$  to  $\tilde{B}, \tilde{F}, \tilde{D}$  such that

$$R_{\bar{\pi}'_2}^{\mathcal{T}_{\pi'_2}}(p_{\hat{D}} \otimes \psi_{\hat{F}} \otimes \bar{k}_{\hat{B}}, q_{\hat{D}} \otimes \varphi_{\hat{F}} \otimes \bar{l}_{\hat{B}}) = R_{\tilde{\pi}'_2}^{\mathcal{T}_{\pi'_2}}(p_{\tilde{D}} \otimes \psi_{\tilde{F}} \otimes \bar{k}_{\tilde{B}}, q_{\tilde{D}} \otimes \varphi_{\tilde{F}} \otimes \bar{l}_{\tilde{B}}). \tag{63}$$

Note that the isomorphisms here are exactly the ones used in the first column of Equation (59). Then we have

$$R_{\bar{\pi}_1 \bar{\pi}'_2}^{\mathcal{T}_{(\pi_1 \parallel \pi_2)\theta}}(\psi_{\hat{E}} \otimes \psi_{\hat{F}}, \varphi_{\hat{E}} \otimes \varphi_{\hat{F}}) = R_{\bar{\pi}_1 \tilde{\pi}'_2}^{\mathcal{T}_{(\pi_1 \parallel \pi_2)\theta}}(\psi_{\hat{E}} \otimes \psi_{\tilde{F}}, \varphi_{\hat{E}} \otimes \varphi_{\tilde{F}}) \tag{64}$$

## B.2 Proof of Theorem 10

We first simplify the adversarial box and prove this theorem by contradiction. Let  $\alpha$  be a box connected with the parallel composition  $\pi_A \parallel \eta_A$ , as shown in Figure 8a. For convenience,  $c_A, K_A$  are relabeled as  $E, K$ . Let  $\mathcal{T}$  be the ordered set of  $\pi_A \parallel \eta_A$ . Without loss of generality, we can assume the final box  $(\pi_A \parallel \eta_A)\alpha$  is defined on the ordered set  $\mathcal{T}$ , because any extra element  $t$  introduced by  $\alpha$  has no effect on  $\pi_A \parallel \eta_A$ .

According to the condition (C1) and (C2), the wire  $(V_1, W_1)$ ,  $(B, D)$  and  $(V_2, W_2)$  are effective only on  $\mathcal{T}_1$ ,  $\mathcal{T}_2$  and  $\mathcal{T}_3$ , respectively. Let  $\{\Phi_\alpha^{\mathcal{C}}\}_{\mathcal{C} \in \bar{\mathcal{C}}(\mathcal{T})}$  be the set of CPTP maps corresponding to  $\alpha$ . Since we are only interested in the final output, we set  $\mathcal{C} = \mathcal{T}$ . By [35, Lemma 9], the map  $\Phi_\alpha^{\mathcal{T}}$  can be decomposed into three maps  $\Phi_{\alpha_1}^{\mathcal{T}} : V_1 \mapsto W_1 Q_1$ ,  $\Phi_{\alpha_2}^{\mathcal{T}} : B Q_1 \mapsto D Q_2$  and  $\Phi_{\alpha_3}^{\mathcal{T}} : V_2 Q_2 \mapsto W_2$  that satisfy

$$\Phi_\alpha^{\mathcal{T}} = (\text{id}_{W_1} \otimes \text{id}_D \otimes \Phi_{\alpha_3}^{\mathcal{T}}) \circ (\text{id}_{W_1} \otimes \Phi_{\alpha_2}^{\mathcal{T}} \otimes \text{id}_{V_2}) \circ (\Phi_{\alpha_1}^{\mathcal{T}} \otimes \text{id}_B \otimes \text{id}_{V_2}). \tag{65}$$

Here  $\Phi_{\alpha_1}^{\mathcal{T}}$ ,  $\Phi_{\alpha_2}^{\mathcal{T}}$  and  $\Phi_{\alpha_3}^{\mathcal{T}}$  can be seen as the map of some boxes  $\alpha_1$ ,  $\alpha_2$  and  $\alpha_3$ , respectively. Similarly, the box  $\eta_A$  is split into  $\eta_{A1}$  and  $\eta_{A2}$ . Let  $\Phi_{\eta_{A1}}^{\mathcal{T}}$  and  $\Phi_{\eta_{A2}}^{\mathcal{T}}$  be the map of

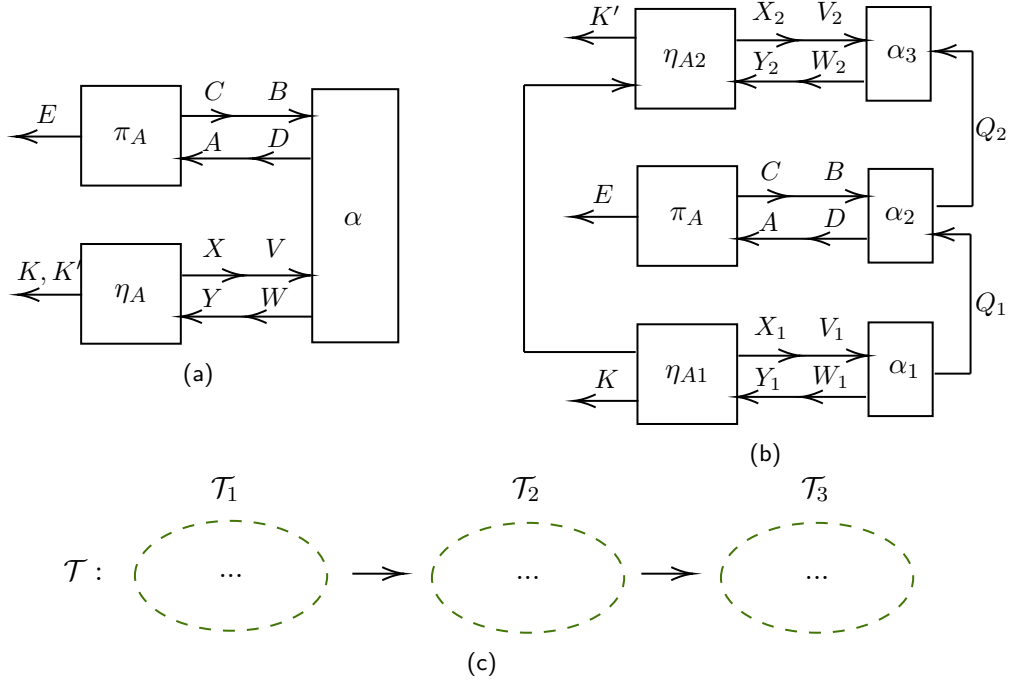

Figure 8: (a) The basic connection. (b) An equivalent form of the box. The wire  $X, Y, V, W$  are split into  $X_1, X_2, Y_1, Y_2, V_1, V_2, W_1, W_2$ . (c) Causal order of the box  $(\pi_A \parallel \eta_A)\alpha$ .

connected boxes  $\eta_A\alpha_1$  and  $\pi_A\alpha_2$ . Denote  $\bar{Q} = \mathcal{F}_Q^T$ , then the output of  $\Phi_{\eta_A\alpha_1}^T$  is a classical-quantum state  $\rho_{\bar{Q}K} = \sum_k P_K(k)|k\rangle\langle k| \otimes \rho_{\bar{Q}}^k$ .  $\Phi_{\pi_A\alpha_2}^T$  is a map from  $\mathfrak{T}(\bar{Q})$  to the classical bit  $E$ , which can be represented as a binary POVM measurement  $\{M_0, M_1\}$ . Then the conditional probability is  $P_{E|K}(e|k) = \text{tr}(M_e \rho_{\bar{Q}}^k)$ .

Assume  $\exists k \in \mathbb{N}, \Pr[E = 1|K = k] \geq z + \epsilon$ , then  $\text{tr}(M_e \rho_{\bar{Q}}^k) \geq z + \epsilon$ . Consider a box  $\gamma$  that outputs state  $\rho_{\bar{Q}}^z$  and has no input. The box  $\pi_A\alpha_2\gamma$  will output  $E = 1$  with probability larger than  $z + \epsilon$ , which contradicts the stand-alone security. Therefore, the first condition in Definition 9 is satisfied. The second condition follows similarly.

### B.3 Proof of Corollary 11

We denote the fractional part of  $z$  as a binary string  $b_1^n$ . We denote the set  $I = \{i \in \mathbb{N} \mid b_i = 1\}$  as a string  $a_1^{|I|}$  and the set  $I' = \{i \in \mathbb{N} \mid b_i = 0\}$  as a string  $a_1^{|I'|}$  in ascending order. The  $i$ th WCF protocol  $\pi_i$  as well as the other WCF protocols  $\pi_1 \parallel \dots \parallel \pi_{i-1}$  and  $\pi_{i+1} \parallel \dots \parallel \pi_n$  output classical bits and follow strict temporal orders. Therefore, we obtain global security of  $\pi_i$  according to Theorem 10

$$\Pr[C_i = 0 | C_1^{i-1} = c_1^{i-1}] \leq \frac{1}{2} + \epsilon, \quad (66)$$

$$\Pr[C_i = 1 | C_1^{i-1} = c_1^{i-1}] \leq \frac{1}{2} + \epsilon. \quad (67)$$

We first argue that a cheating party needs to maximize the winning probability of each  $\pi_i$  in order to maximize the final winning probability. At each step  $\pi_i$ , if  $b_i = 1$ , Alice wins with certainty if  $C_i = 0$  while wins with a probability smaller than 1 if  $C_i = 1$ ; if  $b_i = 0$ , Alice wins with a non-zero probability if  $C_i = 0$  while loses with certainty if  $C_i = 1$ . Therefore, a cheating Alice strives to win at each step  $\pi_i$  in order to finally win with the

highest probability. It is the same for Bob. In conclusion, considering global security in Inequality (67), Alice's winning probability is no larger than the case when

$$\Pr [C_i = 0 | C_1^{i-1} = b_1^{i-1}] = \frac{1}{2} + \epsilon, \quad (68)$$

and Bob's winning probability is no larger than the case when

$$\Pr [C_i = 1 | C_1^{i-1} = b_1^{i-1}] = \frac{1}{2} + \epsilon. \quad (69)$$

We will use the above probabilities to compute the upper bound on Alice and Bob's optimal winning probability.

For a cheating Alice,

$$\Pr[\text{Alice wins}] = \sum_{i=1}^{|I|} \Pr [C_1^{a_i} = (b_1^{a_i-1}, 0)] \quad (70)$$

$$= \sum_{i=1}^{|I|} \Pr [C_{a_i} = 0 | C_1^{a_i-1} = b_1^{a_i-1}] \prod_{j=1}^{a_i-1} \Pr [C_j = b_j | C_1^{j-1} = b_1^{j-1}] \quad (71)$$

$$\leq \sum_{i=1}^{|I|} \left(\frac{1}{2} + \epsilon\right)^{a_i-i+1} \left(\frac{1}{2} - \epsilon\right)^{i-1}, \quad (72)$$

where  $C_1^0 = b_1^0$  is a certain event and Inequality (72) follows from Inequality (67). Similarly, for a cheating Bob, we obtain

$$\Pr[\text{Bob wins}] = \sum_{i=1}^{|I'|} \Pr [C_1^{a'_i} = (b_1^{a'_i-1}, 1)] \quad (73)$$

$$= \sum_{i=1}^{|I'|} \Pr [C_{a'_i} = 1 | C_1^{a'_i-1} = b_1^{a'_i-1}] \prod_{j=1}^{a'_i-1} \Pr [C_j = b_j | C_1^{j-1} = b_1^{j-1}] \quad (74)$$

$$\leq \sum_{i=1}^{|I'|} \left(\frac{1}{2} + \epsilon\right)^{a'_i-i+1} \left(\frac{1}{2} - \epsilon\right)^{i-1}, \quad (75)$$

where we again apply Inequality (67) in (75). Then the bias is

$$\epsilon'_A = |\Pr[\text{Alice wins}] - z| \leq \sum_{i=1}^{|I|} \left(\frac{1}{2} + \epsilon\right)^{a_i-i+1} \left(\frac{1}{2} - \epsilon\right)^{i-1} - \frac{1}{2^{a_i}} \leq \sum_{i=1}^{|I|} \frac{2(a_i - 2i + 2)}{2^{a_i}} \epsilon + o(\epsilon). \quad (76)$$

We have omitted the absolute value because the winning probability of a cheating Alice is larger than that of an honest Alice,  $\Pr[\text{Alice wins}] \geq z$ . Note that

$$\sum_{n=i}^{\infty} \frac{n}{2^n} = \frac{i+1}{2^{i-1}}. \quad (77)$$

When  $|I| = 1$ ,

$$\epsilon'_A \leq \frac{2a_1}{2^{a_1}} \epsilon + o(\epsilon) \leq \epsilon + o(\epsilon). \quad (78)$$

When  $|I| \geq 2$ ,

$$\epsilon'_A \leq \frac{2a_1}{2^{a_1}}\epsilon + \frac{1}{2} \sum_{i=2}^{|I|} \frac{(a_i - 2)}{2^{a_i - 2}}\epsilon + o(\epsilon) \leq \frac{2a_1}{2^{a_1}}\epsilon + \frac{1}{2} \sum_{i=2}^{\infty} \frac{i - 2}{2^{i - 2}}\epsilon + o(\epsilon) \leq 2\epsilon + o(\epsilon). \quad (79)$$

In conclusion, for Alice,

$$\epsilon'_A = |\Pr[\text{Alice wins}] - z| \leq 2\epsilon + o(\epsilon). \quad (80)$$

Similarly for Bob,

$$\epsilon'_B = |\Pr[\text{Bob wins}] - z| \leq 2\epsilon + o(\epsilon). \quad (81)$$

The final bias is

$$\epsilon' = \max\{\epsilon'_A, \epsilon'_B\} \leq 2\epsilon + o(\epsilon) \quad (82)$$

## References

- [1] Robert König, Renato Renner, Andor Bariska, and Ueli Maurer. “Small accessible quantum information does not imply security”. *Phys. Rev. Lett.* **98**, 140502 (2007).
- [2] D. P. DiVincenzo, M. Horodecki, D. W. Leung, J. A. Smolin, and B. M. Terhal. “Locking classical correlations in quantum states”. *Phys Rev Lett* **92**, 067902 (2004).
- [3] Ran Canetti. “Security and Composition of Multiparty Cryptographic Protocols”. *Journal of Cryptology* **13**, 143–202 (2000).
- [4] Ran Canetti. “Universally composable security: A new paradigm for cryptographic protocols”. In Proceedings 42nd IEEE Symposium on Foundations of Computer Science. Pages 136–145. IEEE (2001).
- [5] Ran Canetti, Yevgeniy Dodis, Rafael Pass, and Shabsi Walfish. “Universally composable security with global setup”. In Theory of Cryptography: 4th Theory of Cryptography Conference, TCC 2007, Amsterdam, The Netherlands, February 21-24, 2007. Proceedings 4. Pages 61–85. Springer (2007).
- [6] Dominique Unruh. “Universally composable quantum multi-party computation”. In Henri Gilbert, editor, Advances in Cryptology – EUROCRYPT 2010. Pages 486–505. Berlin, Heidelberg (2010). Springer Berlin Heidelberg.
- [7] Ran Canetti and Jonathan Herzog. “Universally composable symbolic security analysis”. *Journal of cryptology* **24**, 83–147 (2011).
- [8] Ran Canetti, Asaf Cohen, and Yehuda Lindell. “A simpler variant of universally composable security for standard multiparty computation”. In Rosario Gennaro and Matthew Robshaw, editors, Advances in Cryptology – CRYPTO 2015. Pages 3–22. Berlin, Heidelberg (2015). Springer Berlin Heidelberg.
- [9] Ueli Maurer and Renato Renner. “Abstract cryptography”. In Bernard Chazelle, editor, Innovations in Computer Science - ICS 2011, Tsinghua University, Beijing, China, January 7-9, 2011. Proceedings. Pages 1–21. Tsinghua University Press (2011). url: <https://crypto.ethz.ch/publications/files/MauRen11.pdf>.
- [10] Ueli Maurer. “Constructive Cryptography – A New Paradigm for Security Definitions and Proofs”. In Sebastian Mödersheim and Catuscia Palamidessi, editors, Theory of Security and Applications. Pages 33–56. Lecture Notes in Computer Science Berlin, Heidelberg (2012). Springer.

- [11] Hoi-Kwong Lo. “Insecurity of quantum secure computations”. *Phys. Rev. A* **56**, 1154–1162 (1997).
- [12] Hoi-Kwong Lo and H. F. Chau. “Is quantum bit commitment really possible?”. *Phys. Rev. Lett.* **78**, 3410–3413 (1997).
- [13] Dominic Mayers. “Unconditionally Secure Quantum Bit Commitment is Impossible”. *Phys. Rev. Lett.* **78**, 3414–3417 (1997).
- [14] Hoi-Kwong Lo and H.F. Chau. “Why quantum bit commitment and ideal quantum coin tossing are impossible”. *Physica D: Nonlinear Phenomena* **120**, 177–187 (1998).
- [15] Andris Ambainis, Harry Buhrman, Yevgeniy Dodis, and Hein Rohrig. “Multiparty quantum coin flipping”. In Proceedings of the 19th IEEE Annual Conference on Computational Complexity. Page 250–259. CCC '04USA (2004). IEEE Computer Society.
- [16] Carlos Mochon. “Quantum weak coin flipping with arbitrarily small bias” (2007). arXiv:0711.4114 [quant-ph].
- [17] Atul Singh Arora, Jérémie Roland, and Stephan Weis. “Quantum weak coin flipping”. In Proceedings of the 51st Annual ACM SIGACT Symposium on Theory of Computing. Pages 205–216. STOC 2019 New York, NY, USA (2019). Association for Computing Machinery.
- [18] Atul Singh Arora, Jérémie Roland, and Chrysoula Vlachou. “Analytic quantum weak coin flipping protocols with arbitrarily small bias”. In Proceedings of the 2021 ACM-SIAM Symposium on Discrete Algorithms (SODA). Pages 919–938. Proceedings. Society for Industrial and Applied Mathematics (2021).
- [19] Atul Singh Arora, Jérémie Roland, Chrysoula Vlachou, and Stephan Weis. “Solutions to quantum weak coin flipping” (2022).
- [20] Daniel J Bernstein, Johannes Buchmann, and Erik Dahmen. “Post-Quantum Cryptography”. Springer. Dordrecht (2008).
- [21] Ivan Damgård and Carolin Lunemann. “Quantum-secure coin-flipping and applications”. In Mitsuru Matsui, editor, Advances in Cryptology – ASIACRYPT 2009. Pages 52–69. Berlin, Heidelberg (2009). Springer Berlin Heidelberg.
- [22] Urmila Mahadev. “Classical homomorphic encryption for quantum circuits”. *SIAM Journal on Computing* **52**, FOCS18–189–FOCS18–215 (2023).
- [23] Ivan B. Damgård, Serge Fehr, Louis Salvail, and Christian Schaffner. “Cryptography in the bounded-quantum-storage model”. *SIAM Journal on Computing* **37**, 1865–1890 (2008).
- [24] Stephanie Wehner and Jürg Wullschleger. “Composable Security in the Bounded-Quantum-Storage Model”. In Luca Aceto, Ivan Damgård, Leslie Ann Goldberg, Magnús M. Halldórsson, Anna Ingólfssdóttir, and Igor Walukiewicz, editors, Automata, Languages and Programming. Pages 604–615. Lecture Notes in Computer Science–Berlin, Heidelberg (2008). Springer.
- [25] Dominique Unruh. “Concurrent Composition in the Bounded Quantum Storage Model”. In Kenneth G. Paterson, editor, Advances in Cryptology – EUROCRYPT 2011. Pages 467–486. Lecture Notes in Computer Science–Berlin, Heidelberg (2011). Springer.
- [26] Dan Boneh and Victor Shoup. “A graduate course in applied cryptography” (2020).



- [27] David Nowak. “A framework for game-based security proofs”. In Sihan Qing, Hideki Imai, and Guilin Wang, editors, *Information and Communications Security*. Pages 319–333. Berlin, Heidelberg (2007). Springer Berlin Heidelberg.
- [28] Andre Chailloux and Iordanis Kerenidis. “Optimal Bounds for Quantum Bit Commitment”. In 2011 IEEE 52nd Annual Symposium on Foundations of Computer Science. Pages 354–362. (2011).
- [29] André Chailloux and Iordanis Kerenidis. “Optimal Quantum Strong Coin Flipping”. In 2009 50th Annual IEEE Symposium on Foundations of Computer Science. Pages 527–533. (2009).
- [30] Grégory Demay and Ueli Maurer. “Unfair coin tossing”. In 2013 IEEE International Symposium on Information Theory. Pages 1556–1560. (2013).
- [31] V Vilasini, Christopher Portmann, and Lídia del Rio. “Composable security in relativistic quantum cryptography”. *New Journal of Physics* **21**, 043057 (2019).
- [32] Oded Goldreich. “Foundations of cryptography”. Volume 2. Cambridge University Press. (2004).
- [33] Silvio Micali and Phillip Rogaway. “Secure Computation”. In Joan Feigenbaum, editor, *Advances in Cryptology — CRYPTO ’91*. Pages 392–404. Lecture Notes in Computer Science Berlin, Heidelberg (1992). Springer.
- [34] Donald Beaver. “Foundations of Secure Interactive Computing”. In Joan Feigenbaum, editor, *Advances in Cryptology — CRYPTO ’91*. Pages 377–391. Lecture Notes in Computer Science Berlin, Heidelberg (1992). Springer.
- [35] Christopher Portmann, Christian Matt, Ueli Maurer, Renato Renner, and Björn Tackmann. “Causal Boxes: Quantum Information-Processing Systems Closed Under Composition”. *IEEE Transactions on Information Theory* **63**, 3277–3305 (2017).
- [36] Jędrzej Kaniewski, Marco Tomamichel, Esther Hänggi, and Stephanie Wehner. “Secure bit commitment from relativistic constraints”. *IEEE Transactions on Information Theory* **59**, 4687–4699 (2013).
- [37] Yehuda Lindell. “How to simulate it—a tutorial on the simulation proof technique”. *Tutorials on the Foundations of Cryptography: Dedicated to Oded Goldreich* Pages 277–346 (2017).
- [38] Gus Gutoski and John Watrous. “Toward a general theory of quantum games”. In *Proceedings of the Thirty-Ninth Annual ACM Symposium on Theory of Computing*. Page 565–574. STOC ’07 New York, NY, USA (2007). Association for Computing Machinery.
- [39] Giulio Chiribella, Giacomo Mauro D’Ariano, and Paolo Perinotti. “Theoretical framework for quantum networks”. *Physical Review A* **80**, 022339 (2009).
- [40] Carl A. Miller. “The impossibility of efficient Quantum weak coin flipping”. In *Proceedings of the 52nd Annual ACM SIGACT Symposium on Theory of Computing*. Pages 916–929. STOC 2020 New York, NY, USA (2020). Association for Computing Machinery.
- [41] Vedran Dunjko, Joseph F. Fitzsimons, Christopher Portmann, and Renato Renner. “Composable Security of Delegated Quantum Computation”. In Palash Sarkar and Tetsu Iwata, editors, *Advances in Cryptology – ASIACRYPT 2014*. Pages 406–425. Lecture Notes in Computer Science Berlin, Heidelberg (2014). Springer.

- [42] Anne Broadbent, Joseph Fitzsimons, and Elham Kashefi. “Universal Blind Quantum Computation”. In 2009 50th Annual IEEE Symposium on Foundations of Computer Science. Pages 517–526. (2009).
- [43] Joseph F. Fitzsimons. “Private quantum computation: An introduction to blind quantum computing and related protocols”. *npj Quantum Information* **3**, 1–11 (2017).