

Paving the Path to a Green and Self-Powered Internet of Things

Mahyar Shirvanimoghaddam, Kamyar Shirvanimoghaddam, Mohammad Mahdi Abolhasani, Majid Farhangi, Vahid Zahiri Barsari, Hangyue Liu, Mischa Dohler, and Minoo Naebe

Abstract—Internet of things (IoT) is a revolutionizing technology which aims to create an ecosystem of connected objects and embedded devices and provide ubiquitous connectivity between trillions of not only smart devices but also simple sensors and actuators. Although recent advancements in miniaturization of devices with higher computational capabilities and ultra-low power communication technologies have enabled the vast deployment of sensors and actuators everywhere, such an evolution calls for fundamental changes in hardware design, software, network architecture, data analytic, data storage and power sources. A large portion of IoT devices cannot be powered by batteries only anymore, as they will be installed in hard to reach areas and regular battery replacement and maintenance are infeasible. A viable solution is to scavenge and harvest energy from environment and then provide enough energy to the devices to perform their operations. This will significantly increase the device life time and eliminate the need for the battery as an energy source. This survey aims at providing a comprehensive study on energy harvesting techniques as alternative and promising solutions to power IoT devices. We present the main design challenges of IoT devices in terms of energy and power and provide design considerations for a successful implementations of self-powered IoT devices. We then specifically focus on piezoelectric energy harvesting and RF energy harvesting as most promising solutions to power IoT devices and present the main challenges and research directions. We also shed light on the security challenges of energy harvesting enabled IoT systems and green big data.

Index Terms—Energy harvesting; Internet of Things (IoT); RF energy harvesting; piezoelectric.

I. INTRODUCTION

RECENT advancements in miniaturization of devices with higher computational capabilities and ultra-low power communication technologies are driving forces for the ever growing deployment of embedded devices in our surroundings. This will transform every physical object, or *thing*, into an information source with the potential to communicate with every other thing in the network. This ecosystem of connected things are called *Internet of Things (IoT)* which aims at transforming the world into a fully digital and inter-connected world.

M. Shirvanimoghaddam is with the Centre for IoT and Telecommunications, School of Electrical and Information Engineering, The University of Sydney, NSW, Australia (email: mahyar.shm@sydney.edu.au).

K. Shirvanimoghaddam and M. Naebe are with The Institute for Frontier Materials, Deakin University, VIC, Australia (email: {kshirvani, minoo.naebe}@deakin.edu.au).

M. M. Abolhasani is with Chemical Engineering Department, University of Kashan, Kashan, Iran (email: abolhasani@kashanu.ac.ir).

M. Farhangi, V. Zahiri Barsari, and H. Liu are with the School of Electrical and Information Engineering, The University of Sydney, NSW, Australia (email: {mfar8291, vzah5643, hliu7760}@uni.sydney.edu.au).

M. Dohler is with the Centre for Telecommunications Research, Department of Informatics, King's College London, UK (email: mischa.dohler@kcl.ac.uk).

IoT applications and services cover almost any sector where embedded devices can replace human in performing tasks. Examples are home automation, agriculture, smart cities, industrial automation, healthcare, remote monitoring, and many more. IoT provides a network of connected devices that real time information can be shared and used in order to enhance life quality, improve industry processes, energy efficiency, and level of services. IoT significantly improves supply chain efficiencies and develop new services for retailers [1]. Such a network of inter-connected devices enables the factories to get humans and enterprise systems more involved with the machines in the whole supply chain system. This will improve the total revenue and improve customer satisfaction, and bring the customer experience into a whole new level. Fig. 1 shows a wide range of IoT applications and services.

Gartner estimated that the total number of IoT devices will reach 8.4 billion in 2017. This is equivalent to about 31 percent increase from 2016, and will reach 20.4 billion by 2020 [2]. Only a small fraction of these devices will be our smart phones and computers and a majority of them perform simple tasks such as sensing and transmitting a small amount of data once in a while. Major industries will be equipped with embedded smart sensors to gather data from their machinery to better track inventory and manage machines. This will significantly increase efficiency, revenue, and save costs and even lives. Intel reported that IoT technology will worth about USD 5.2 trillion globally, where healthcare and manufacturing will share USD 2.5 trillion and USD 2.3 trillion, respectively [3].

Devices in IoT are usually divided into two main categories. Basic devices only provide basic services of sensor reading and/or actuation tasks, and some limited support for user interaction. They have basic processing and communication capabilities with limited memory and they are usually running with small batteries. Basic devices are usually used in *massive IoT* applications, such as consumer electronics and smart metering. In massive IoT, devices must have very low power consumption and the network should provide long coverage. Also due to the massive scale of the system, the devices should be of low cost and maintenance. On the other hand, advanced devices are capable of running complex tasks and usually support cellular and wide area network connections. Examples of advanced devices are smart phones and laptops. These devices are widely used in *critical IoT* applications, with high demands for reliability, availability, and low latency.

Powering the IoT devices is a major challenge, which becomes crucial with the fast development of relative technologies [4]. In fact in many IoT applications, devices need to be powered in a self-sufficient and sustainable fashion. Most of the devices will be battery operated due to cost, convenience,

size, and the fact that they are implemented in hard-to-reach areas. In many IoT applications, long life time of the devices is of prominent need, as the battery maintenance is not feasible due to cost, inconvenience, and the size of the networks. Recent studies showed that more than 3 billion batteries are discarded in the USA every year [5], and the penetration of IoT technologies in every sector will exacerbate this problem.

The trend so far to improve energy efficiency and propose viable solutions for long-life time devices for IoT has been mainly focused on two main directions. First, is to reduce the energy consumption of every component of the device in any operation mode, including embedded sensors, microprocessors, and transceivers. Second, is to increase battery efficiency and have smaller yet more efficient batteries. While in many cases these trends have achieved significant improvements, there are still major challenges which have not been solved yet. In fact, the IoT applications which only rely on batteries require battery replacement; otherwise node failure will dramatically drop the system performance. Battery replacement is however not a feasible option due to cost and physical operations.

Energy harvesting (EH) provides several solutions for powering IoT. EH techniques harvest energy from different energy sources in the environment, such as thermal, vibrations, solar, and radio frequency (RF) signal energy. This provides a potentially unlimited power supply for IoT devices and significantly increases the device life-time. Energy harvesting market has experienced a huge growth from \$131.4 million in 2012 to \$4.2 billion in 2019¹. The main reasons behind this growth are 1) the demand for micro-power generation to charge thin film batteries, 2) recent advancements in energy storage devices, i.e., batteries and super-capacitors, 3) the efficiency of EH devices have significantly improved and 4) the fact that the price of super-capacitors and thin-film batteries dramatically decrease. There are also significant cost reductions, which makes them suitable choices for a wide adoption in IoT applications.

Energy harvesting has been widely studied in the context of wireless sensor networks (WSNs) [7] and wireless body area networks (WBANs) [8] in the literature. These studies have mainly focused on 1) energy harvesting technologies [9], [10], 2) power management mechanisms [11], [12], 3) challenges and practical issues of energy harvesting for WSNs [13], and 4) sensor node design [14]. However, due to unique requirements of emerging IoT applications and the differences between IoT in general and WSNs, there is a major need to study and investigate the EH techniques for the specific uses for IoT. IoT devices may interact with multiple network tiers to deliver their messages and receive feedbacks and act upon the command received from the network. Also, most studies on EH techniques for WSNs have focused on short-range communication technologies, which might not be suitable for many IoT applications. In fact, several low-power wide area networks (LPWAN) have been proposed and implemented to provide long coverage and high capacity IoT services. The IoT Global Forecast & Analysis 2015-2025, from Machina

Sector	Applications	Locations	Devices
Building	Commercial/Institutional	Office, Education, Retail, Hospitality, Healthcare, Airports, Stadiums	HVAC, Transport, Fire & Safety, Lighting, Security, Access, etc.
	Industrial	Process, Clean Room, Campus	
Energy	Supply/ Demand	Power Gen., Trans. & Dist., Low Voltage, Power Quality, Energy Management	Turbines, Wind-mills, UPS, Batteries, Generators, Meccas, Drills, Fuel Cells, etc.
	Alternatives	Solar, Wind, Co-generation, Electrochemical	
	Oil/Gas	Rigs, Derricks, Well, heads, Pumps, Pipelines	
Consumer & Home	Infrastructure	Wiring, Network Access, Energy Management	Digital Camera, Power systems, Dishwashers, Desktop computers, Washers/Dryers, Lighting, TVs, MP3, game consoles, etc.
	Awareness & Safety	Security, Alert, Fire Safety, Environ. Safety, Elderly, Children, Power Protection	
	Convenience & Entertainment	HVAC/Climate, Lighting, Appliances, Entertainment	
Healthcare & Life Science	Care	Hospital, FR, Mobile POC, Clinic, Labs, Doctor Office	MRI, PDAs, Implants, Surgical Equipments, Telemedicine, etc.
	In Vivo/Home	Implant, Home Monitoring Systems	
	Research	Drug Discovery, Diagnostics, Labs	
Industrial	Distribution	Pipelines, Mar handling, Conveyance	Pumps, Valves, Conveyors, Pipelines, Motors, Drives, Conveying, Fabrication, Assembly/Packaging, Vessels/trains, etc.
	Converting/Discrete	Metals, Paper, Rubber/Plastic, Metalworking, Electronics, Assembly/Test	
	Fluid Process	Retro-Chem., Hydro, Carbons,	
	Resource Automation	Mining, Irrigation, Agricultural, Woodland	
Transportat	Non-Vehicular	Air, Rail, Marine	Vehicles, Lights, Stops, Signage, Tolls, etc.
	Vehicles	Consumer, Commercial, Construction, Off-Hiway	
	Trans Systems	Tolls, Traffic Management, Navigation, Parking	
Retail	Specialty	Fuel Stations, Gaming, Bowling, Cinemas, Discos, Special Events	POS terminals, Cash Registers, Vending Machines, Sings, etc.
	Hospitality	Hotels, Restaurants, Bars, Cafes, Clubs	
	Stores	Supermarkets, Shopping Centers, Single Site, Distribution Centers	
Security & Public Safety	Surveillance	Radar/Satellite, Environ, Military Security, Unmanned	Fighters, Battlefields, Jeeps, Cars, Ambulances, Homeland Security, Fire safety, etc.
	Equipment	Weapons, Vehicles, Ships, Aircrafts, Gear	
	Tracking	Human, Animal, Postal, Food/Health, Packaging, Baggage	
	Public Infrastructure	Water treatment, Env./Building Monitoring	
IT & Networks	Emergency Service	Equips, Personnel, Police, Fire, Regulatory	
	Public	Service, E-commerce, data Centres, Mobile Carriers, Fixed Carriers, ISPs	Servers, Storage, PCs, Routers, Switches, Laptops, etc.
	Enterprise	IT/Data Centre, Office, Private Networks	

Fig. 1. IoT Sectors. The information in this figure has been obtained from [6].

Research expects that 11% of IoT connections in 2025 to use LPWAN connectivity technologies [15]. This shows the need for the comprehensive study of self-powered solutions for emerging IoT applications which are enabled using LPWAN technologies. This paper reviews several energy harvesting techniques, provides insights on the design of suitable self-powered IoT devices, discusses pros and cons of each EH technique, provides some detailed discussions on the piezoelectric energy harvesting materials and design for self-powered IoT, and finally discusses the future challenges of self-powered IoT. The paper is of survey nature aiming at paving the path to a green and self-powered IoT ecosystem.

The remainder of the paper is organized as follows. In Section II, we briefly introduce Internet of Things and different applications and requirements. Section III provides a comprehensive overview of energy in IoT ecosystem, where we also discuss about IoT devices, energy harvesting use cases in IoT. In Section IV, different approaches to power IoT devices are studied and pros and cons for each approach are explained. In Section V, we focus on piezoelectric energy harvesting and provide a comprehensive study on piezoelectric effect, mode

¹<https://pitchengine.com/pitches/59354ec3-359e-4476-89ef-2ce639997a21>

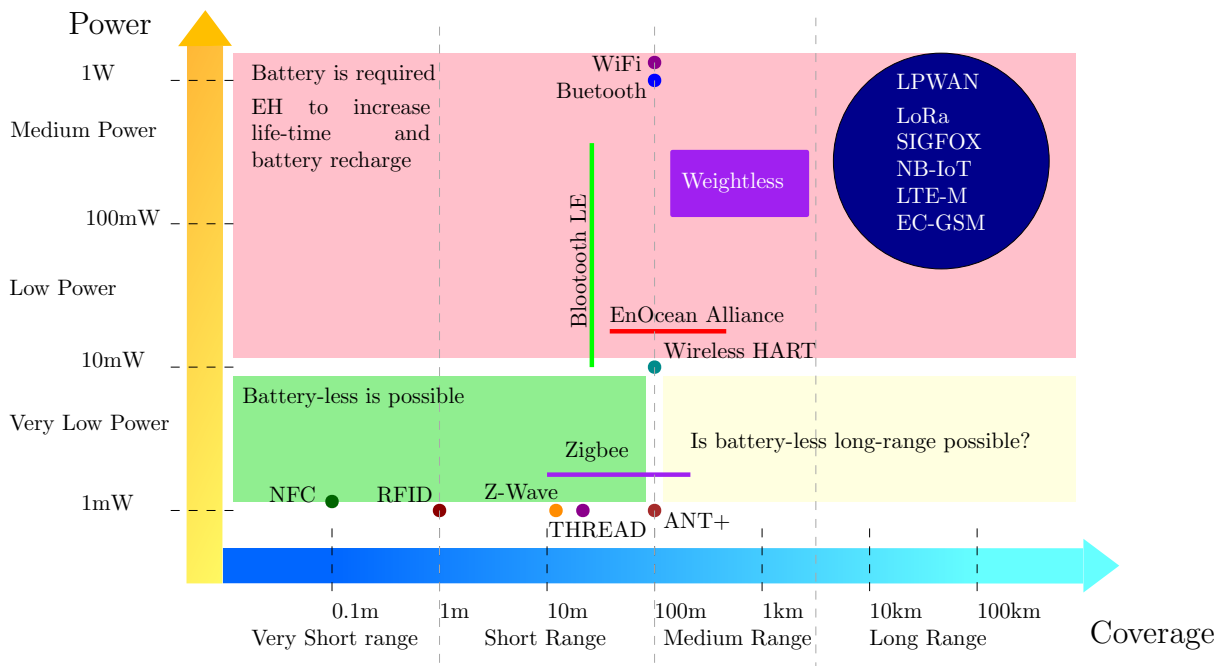

Fig. 2. Power consumption versus coverage for different wireless technologies.

of use, and piezoelectric materials. In Section VI, we focus on RF energy harvesting for IoT and discuss about the challenges and research directions. Security challenges of EH-enabled IoT systems are discussed in Section VII. We also briefly explain the green big data concept and shed light on the challenges and future research directions. Finally, Section IX concludes the paper.

II. AN OVERVIEW ON IoT

Internet of Things has attracted enormous attention from both industry and research sectors. This is mainly because of huge opportunities that IoT will create in near future. IoT goes beyond personal computers and mobile phones, and converts every physical object to an information source and connect them to the Internet or local area networks. IoT services are mainly categorized into *massive IoT* and *critical IoT*. In Massive IoT, countless devices will send data to the servers via Internet or local networks. The devices therefore should operate with low power, low complexity, and of course must be of low cost. Critical IoT has completely different requirements such as, high reliability, availability and low latency; therefore more complex devices are required. Remote health care and traffic safety and control are examples of critical IoT services.

The third generation partnership project (3GPP) has identified 4 different application family types, see Fig. 7 of massive IoT applications which will rely on LPWAN solutions. These include [16]:

- 1) Type 1 is tracking, assisted living, remote health monitoring, wearables and bicycle tracking. They require 5 years battery life, which can be also supported by energy harvesting for battery recharge, medium coverage, and latency of about 30 seconds (lower latency of 5 seconds is required for VIP tracking). They also require high mobility support.

- 2) Type 2 is industrial asset tracking, microgeneration, agricultural livestock and environmental near real time monitoring. They require 5 to 10 years battery life time, latency of less than 1 seconds, and medium coverage.
- 3) Type 3 mainly requires deep indoor coverage for smart metering, smart parking, smart building, home automation, and industrial machinery control. It also requires extended outdoor/rural coverage, for smart cities, waste management, agricultural stationary asset monitoring, and environmental sensor and data collection. They require very long battery life of 10 to 15 years, extended coverage, latency of 10 to 60 seconds, and low mobility support.
- 4) Type 4 is usually main powered, such as smart city lighting, home appliances and vending machines which are stationary. Low mobility support, indoor and outdoor coverage, and latency of less than 30 seconds are required. For vending machines latency of about 1 second is required.

Type 1, 2 and 3 are battery powered and require the battery life-time of 5 to 15 years. In Type 1 applications, the battery can be easily recharged, but for other types battery replacement/maintenance is an issue. 3GPP has also identified five challenges for the vast deployment of IoT services: 1) *device cost*, 2) *battery life*, 3) *coverage*, 4) *scalability*, and 5) *diversity* [17].

Machina Research [15] estimated that capillary or short-range wireless technologies will service more than 70% of all IoT devices. Most of these devices will be used in indoor environment and they have limited service demand and security requirements. From the market perspective, consumer electronics and building security and automation are the biggest short-range applications. It was also estimated that by 2025

more than 11% of IoT connections will use LPWAN [15]. Extended coverage GSM (EC-GSM), narrow band IoT (NB-IoT), and LTE for MTC (LTE-M) are three main solutions which have been proposed by 3GPP for massive IoT. These low power technologies were mainly designed to increase the battery life-time and the coverage, suitable for many IoT applications. Low power in this context refers to the ability of the IoT device to work for many years on a single battery charge. Long battery life-time is mainly achieved by defining new control and data channels and new power-saving and duty-cycling functionalities for IoT applications [17].

Fig. 2 shows the power requirement for several wireless technologies and their coverage. While short-range wireless communications operate over very low power which might be suitable for many IoT applications, they might not be feasible for applications that require long coverage. In fact, to have long coverage the transmit power needs to be increased. Several low-power solutions have been proposed so far, which the transmit power ranges from 0.2 to 1 watt. This is much higher than what many short-range wireless technologies require, which may hamper the success of implementing self-powered LPWAN systems. In fact, due to the large transmit power of most LPWAN technologies, batteries will remain an essential parts of IoT devices operating over LPWANs. Energy harvesting techniques will then play a key role in increasing the device life-time by providing a sustainable way to recharge the batteries.

A. System Models For Energy Efficient IoT

There have been several types of models and algorithms proposed aiming for low-power IoT. In the load control level, aiming for high energy efficient IoT applications with minimum performance sacrifice, and considering the dynamic load current range for different IoT applications, the Dynamic Voltage and Frequency Scaling (DVFS) [18] techniques have widely deployed in many IoT load circuits to deliver reliable, low ripple, rapid responsive characteristics. The techniques have been studied in terms of digital and analog linear regulators, or Low dropout regulators (LDOs) [19].

Sarder et al. [20] have proposed a system model for the energy efficient green-IoT. The model consists of physical devices, embedded web server, cloud environment that includes virtual environment and server application and interface and application repository, and according user group and application that has been divided into admin access application and client access application. The core idea in this scheme is energy saving based on their energy efficient scheduling algorithm that collaborate three modes on-duty mode, pre-off-duty mode and off-duty mode, as shown in Fig. 3. The capabilities under different stages vary, and should switch to different modes according to the commands received from the previously mentioned embedded web server. At the on-duty stage in this model, in order to reduce the energy consumption, the physical devices are only capable as either a relay node or a sink node, while the processing responsibilities at this stage have been shifted to the virtual environment in the aforementioned cloud environment which could also ensure

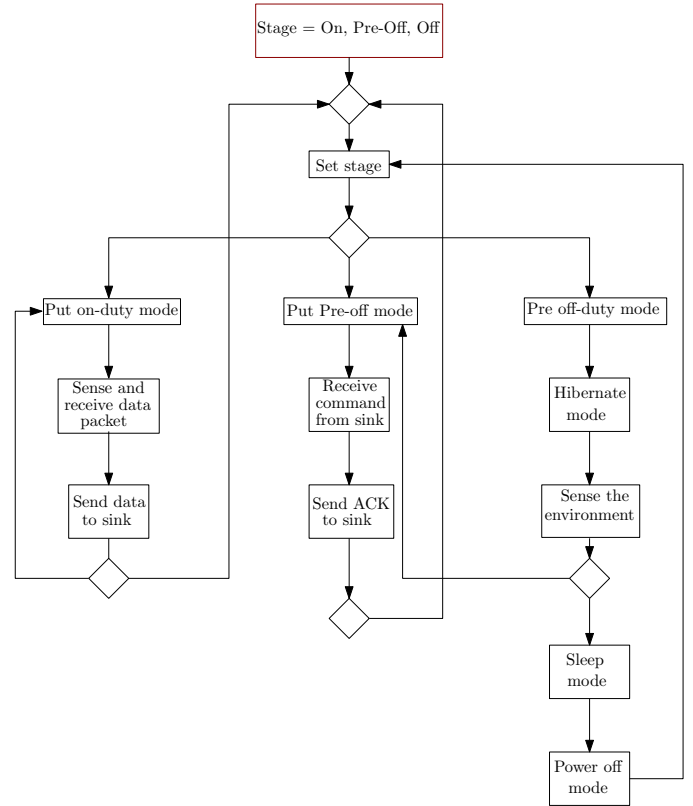

Fig. 3. Energy efficient algorithm activity diagram [20].

the quality of data processing and thus enhance the overall system performance. Moreover, the pre-off-mode in this scheme is only capable for sensing changes in the environment that required to be transmitted. On the other hand, the most energy efficient mode in this model is the off-duty mode that have three sub-modes including hibernate mode, sleep mode and power-off mode. The hibernate mode indicates the first stage of off-duty mode, at which the devices are still capable for sensing the changes in the environment and receiving changing requirements. The sleep mode indicates the further stage of off-duty mode, followed by the power-off mode, when the devices could only be woken up by direct triggering operation from the sink node.

However, there are a few potential issues here, the first one of which is the versatility of the scheme, as the low data capability and transmitting all the data to the cloud environment could not be suitable for many industrial applications. Moreover, the sophisticated multiple-mode scheme may affect the responding speed of the system, which is highly desired in many IoT applications.

B. Hardware-Based Techniques to Improve Energy Efficiency

Many studies have been conducted focusing on how to reduce energy consumption of IoT devices in terms of both hardware design and software application design for low-power and even ultra-low-power IoT applications. The design of low-power devices themselves have been popular in the IoT field. For example, Akella Kamakshi et al. [21] proposed a 0.2 V, 23 nW, fully on-chip CMOS ultra-low-power temperature sensor that is capable for resolution-power trade-off with wide

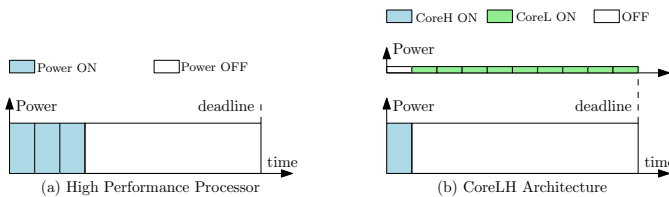

Fig. 4. Comparison between a High performance processor and proposed CoreLH architecture [27].

ranges of sampling rates and energy needs. Park et al. [22] introduced an architecture for special designed low-power microcontroller that is based on event-driven signal processing unit for rare event sampling devices. This microcontroller has reduced the energy consumption by 80% compared with conventional sensor with traditional data processing method. Texas Instruments (TI) have announced a new platform in 2015, named new SimpleLink ultra-low power wireless microcontroller platform. With this platform that supports multiple communication wireless technologies, the IoT network would be able to go battery-less with energy harvesting techniques [23].

In [24] it has been studied how designing of a system-on-a-chip (SoC) can mitigate the negative environmental effects of developing billions of IoT devices. SoCs are defined as battery less/ ultra-low-power single-chip devices to be implemented at low die area with high computing capability [24]. It has been reported that Ultra-low-voltage (0.3-0.5V) CMOS processors have shown promising speed performance requiring to be supplied by an embedded on-chip DC/DC converter. In other words, SoC concept demonstrates how combining the sensors and hardware accelerators on a single chip can mitigate the e-waste and carbon footprint and reduce the system energy consumption.

Subthreshold operation was studied in [25] to decrease the power consumption of the battery powered devices. Since the dynamic energy dissipation which can be expressed as CV^2DD is heavily depend on supply voltage. Thus, considerable power saving can be achieved when the supply voltage of the circuit is reduced below the transistors' threshold voltage. However, consequent lower current operation leads to increasing the propagation delay of the transistors and hence decreasing the system speed. Although, subthreshold operation can be used in low power wireless network or implantable medical devices, such systems are sensitive to variation of process parameters such as temperature and supply voltage. In [26], adaptive and low power circuit is proposed to control both frequency and supply voltage so that oscillation period can be adjusted to the critical path delay.

In [27] a novel core processor for IoT has proposed which consists CoreL and CoreH for low computation and high computation tasks respectively. CoreL is designed to be 4 times slower than CoreH which results the efficiency to be 3xhigher. Fig. 4 shows the task assigning to different cores in which a proper scheduler leads the CoreH to run 2 cycles and the rest of the task is run by CoreL. A 44% energy saving has been reported as the result of this architecture.

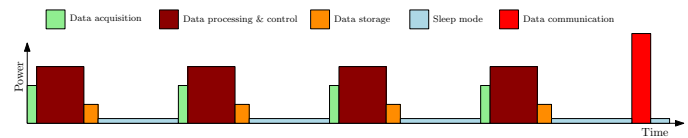

Fig. 5. Typical modes of operation for IoT devices [28].

C. Software-Based Techniques to Improve Energy Efficiency

One of the overlooked areas in IoT system energy efficiency is networking. In [29], an energy-aware routing protocol has been proposed based on modifying the objective function of the optimization in RPL, called *Green-RPL*. Network metrics has been used to minimize the carbon footprint and ensure Quality of Service (QoS) for demanding multimedia services through finding a path for data transmission with lower total energy consumption. It has been shown that overall energy efficiency of the network can be improved significantly by employing advanced and energy-aware routing methods. However, determining the actual power consumption of the nodes in a network can be challenging due to highly variable nature of wireless networks.

Wireless Sensor Network is one of the key enabling technologies in IoT implementations. In [30], a Compressed Sensing (CS) technique has been used to improve the energy efficiency of a Wireless Body Sensor Network (WBSN) for real-time ECG monitoring system. CS methods are based on the compression of the sensed data before sending them on the wireless channel. Employing appropriate compression methods, not only can shorten the wireless transmission time and reduce wireless transceivers power consumption, but also can reduce the overall consumed power by the processor itself, thus results in a longer battery life.

In [31], a framework for evaluating energy efficiency of cloud computing platform has been implemented and it has been shown that the virtualization technology can improve the total energy efficiency of the platform. In the proposed method, heterogeneous Virtual Machines (VMs) and mini clouds were used to perform the data processing at different layers of the cloud network with different processing capabilities. Applying this method can save up to 21% of the consumed power by the cloud network.

Controlling each node status is proposed in [20] to reduce the power consumption during idle time. A centralized webserver has been used to schedule the operational time for each node in the WSN. For each node in the network, 3 states can be selected: on-duty, pre-off duty and off-duty which are corresponding to full processing and communication capability, limited processing and transmission capability and minimized capabilities and power consumption, respectively. Through controlling the active and sleep time for each device in the network, a considerable amount of energy can be saved. J. Huang et al. [32] proposed a minimal energy consumption algorithm (MECA) to solve the energy efficiency optimisation problem in their proposed hierarchical IoT network framework. The algorithm deploys both K-mean clustering algorithm and the Steiner tree methodology and the system framework consists of sensing layer with objects, relay layer with relays and convergence layer with base stations. The

clustering algorithm is firstly deployed to select the closest relays in the IoT system framework for each cluster of objects in the sensing layer. After that, the MECA further process the algorithm for later deploying the Steiner tree algorithm. In order to do this, it assigns each edge with a weight through mapping the transmitting energy and receiving energy of the connected node pairs, and then based on which constructs a graph. Finally, with these steps done, the energy consumption tree could be developed by utilising the aforementioned Steiner tree methodology. It is worth mentioning here that the link weight deployed in this proposed scheme is the energy consumption rather than any other variables, in which way the energy efficiency is considered predominantly when for the optimal locations and numbers of the relays. This proposed algorithm, according to their tests, enables the system in balancing the network load and hence energy consumption as well as extending its lifespan.

Research has been also carried out to optimize the operations of the IoT devices and energy distribution based on variable control algorithms such that the energy could be utilised in the most efficient way possible [33]. The Silicon Labs has delivered power management tools with its sensing and wireless connectivity solutions, microcontrollers. Together with the application programming interfaces (API) provided by ARM, they built the integrated low-power IoT device platforms based on customisable power management API [34]. Technically the power consumption optimisations consider four stages of the IoT functional operations, from data acquisition, data processing and control to data storage, data transmission and communication. As shown in Fig. 5, these four stages essentially work in sequence under either two modes basically sleep mode and operation mode with a transition stage in between typically named wake-up.

Nonetheless, the energy saving requirements have also brought up some issues. For example, the low-power requirements usually sacrifice the capability of IoT devices to implement the cryptography algorithms since these algorithms often rely on heavy energy consumption [35].

III. ENERGY IN THE IOT ECOSYSTEM

IoT consists of several layers of devices, ranging from tiny devices to giant data centers. Fig. 6 shows some of energy consumers in the IoT ecosystem. In the large scale, there are data centers and network infrastructure, which consume huge amount of energy; expecting to dramatically increase in near future. In the small scale, there are traditional network devices, such as mobile phones and tablets, computers and home entertainment, and IoT specific devices, which are somehow new to the market and are expected to grow exponentially in terms of the numbers. Only a small fraction of these devices are powered by connecting to the main power, and most of them would be battery operated or self-powered and use energy harvesting technologies. These were enabled through technological advancements in miniaturization of electronic devices, low power processing, low power wireless communications, and battery and energy storage, and the continuing fall in their prices and sizes. However, the unique characteristics

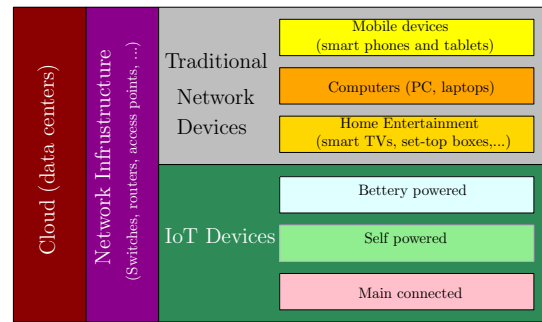

Fig. 6. Energy consumers in the IoT ecosystem.

of IoT systems open new challenges and problems in terms of energy, which are needed to be solved to enable sustainable and autonomous IoT systems and applications.

A. Characteristics of IoT Energy Sources

Here, we list these unique challenges of IoT systems and devices which must be carefully considered when designing the devices and communications protocols.

1) *Scalability*: The energy source for IoT devices must be **scalable**. For the vast deployment of IoT services and applications, the devices need to be placed in all kinds of locations to collect data and communicate with the gateways. The devices may be located in hard-to-reach areas, so they need to work autonomously without human intervention. They also require minimum maintenance; therefore, batteries are not viable solutions.

2) *Maintenance-free*: The energy source for most IoT applications must be **maintenance-free**. IoT and MTC use cases usually involve a large number of devices. Connecting these devices through wiring to the main power is not feasible, as it restrict device movements and also increase the total deployment cost. Batteries are not feasible either as regular battery maintenance is impractical due to the large number of devices, the cost associated with batteries and also the enormous scale of maintenance expenses.

3) *Mobility support*: Energy sources for many IoT application must **support mobility**. Many IoT devices are mobile, and the constant movement of the devices must be carefully considered when designing the devices and power management systems.

4) *Long life-time*: Many IoT applications required energy sources that supports **long life-time** with minimal maintenance. In some IoT applications, for example in structural health monitoring, embedded wireless sensors must be deployed inside the buildings, bridges, etc., and they are supposed to work for several decades. In these applications, both the energy storage and wireless connectivity must be optimized in order to maximize the lifetime of the device.

5) *Flexibility*: IoT energy sources must be **flexible in size and capacity** due to wide variety of IoT applications and services. For example in health monitoring applications, a tiny device will be implanted inside the human body to sense vital information and send it to a personal device. This requires long-lifetime tiny batteries or energy-harvesting enabled batteries. Many other applications, such as parking

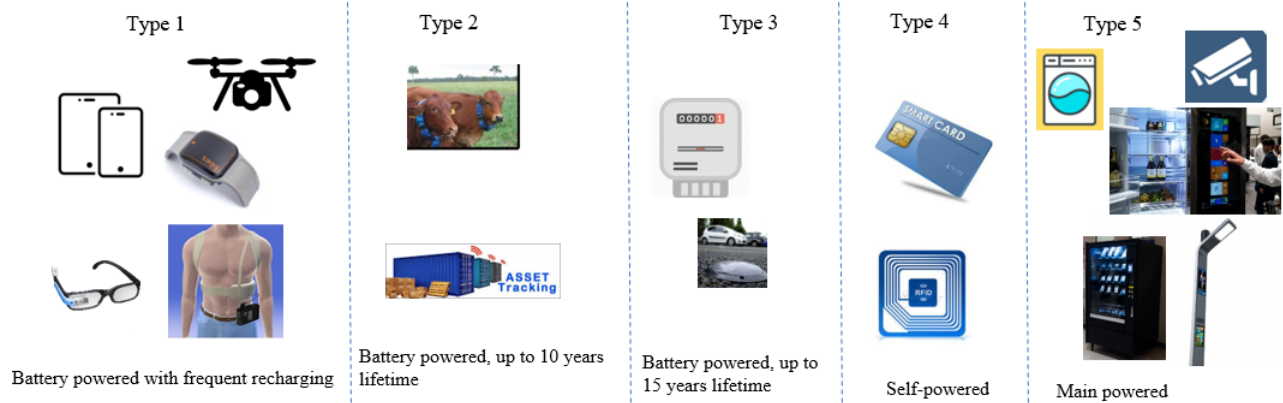

Fig. 7. Different types of IoT devices.

meters, may be connected to main power or can benefit from large photovoltaic cells due to their size and locations.

6) *Low-cost*: Many IoT applications will require a large number of devices to be installed. These devices, and accordingly their power sources, should be of low cost; otherwise the application will provide low revenue or is very expensive, which limit its popularity.

7) *Sustainability*: IoT will include trillions of devices, in different scales, and all of them consume power, which will affect our environment. IoT power solutions must be sustainable to avoid the depletion of natural resources in order to maintain an ecological balance. This further emphasizes the importance of energy harvesting power sources for IoT as alternatives to conventional non-environmentally friendly power sources.

8) *Environment-friendly*: The expansion of IoT services will negatively impact the environment due to a large number of battery discarding, e.g., more than 125,000 tons of batteries are discarded in USA every year. Discarded AA batteries would circle the earth six times which worsen the problem. Addressing this problem is of urgent priority and energy harvesting techniques provide several solutions.

B. Powering IoT Devices

Authors in [5] have divided the IoT devices into five categories as follows:

- Type I devices is wearable devices, such as smart watches and fitness monitors, which have longevity requirement of several days as the number of them per user is small and they can be regularly recharged.
- Type II devices are set-and-forget devices, such as home security, with the longevity requirement of several years and a user may have dozens of them, so regular replacement of batteries is inconvenient.
- Type III devices are semi-permanent devices, which are deployed in bridges, buildings, and infrastructures for monitoring purposes, and expected to work for more than a 10 years. Regular replacement of batteries infeasible.
- Type IV devices are battery-less and self powered devices, such as RFID tags and smart cards.

- The last type, i.e., Type V devices, are powered appliances, such as smart refrigerators, that are always connected to the main power.

Type II, III, and IV devices usually require long lifetime energy sources as regular battery replacement is infeasible due to the large number of devices or hard-to-reach areas where the devices are deployed. In fact, most of IoT devices need small-sized and high-energy density batteries for longer lifetime. This calls for major technological improvements in battery development. Energy harvesting (EH) techniques are interesting alternatives to batteries, which promise to enable autonomous and deployable IoT applications, in energy-rich environments [36]. Extracting energy from the environment, enables the devices to reincarnate once they have accumulated enough energy from the ambience. Energy harvesting is then become an excellent choice for applications, which require increased lifetime, battery-less functionality and ease of maintenance [37].

C. Energy Harvesting Use Cases in IoT

EH techniques use different sources of energy in the surrounding environment to harvest enough energy which is used later by the device for sensing, actuating, and communicating with the server. Solar, thermal, vibration, RF signals, and human body are only few examples of the available energy sources in the environment commonly used for energy harvesting. There are several scenarios where EH technologies can significantly enhance the system wide performance, in terms of energy, network life time, cost and maintenance. We divide these scenarios into three categories as detailed below.

First, energy harvesting is mostly useful in applications where devices are deployed in hard-to-reach areas, therefore, replacing the batteries for sensor nodes is almost impossible [39]. Wireless sensor networks (WSNs) have been widely studied for structural health monitoring, where the damage in aerospace [40], buildings [41], bridges [42], and mechanical infrastructures is detected by sensor nodes. The goal is to replace qualitative visual inspection and time-based maintenance procedures with a more autonomous condition-based damage assessment processes [43]. The aircraft health monitoring system using WSNs and energy harvesting techniques, including

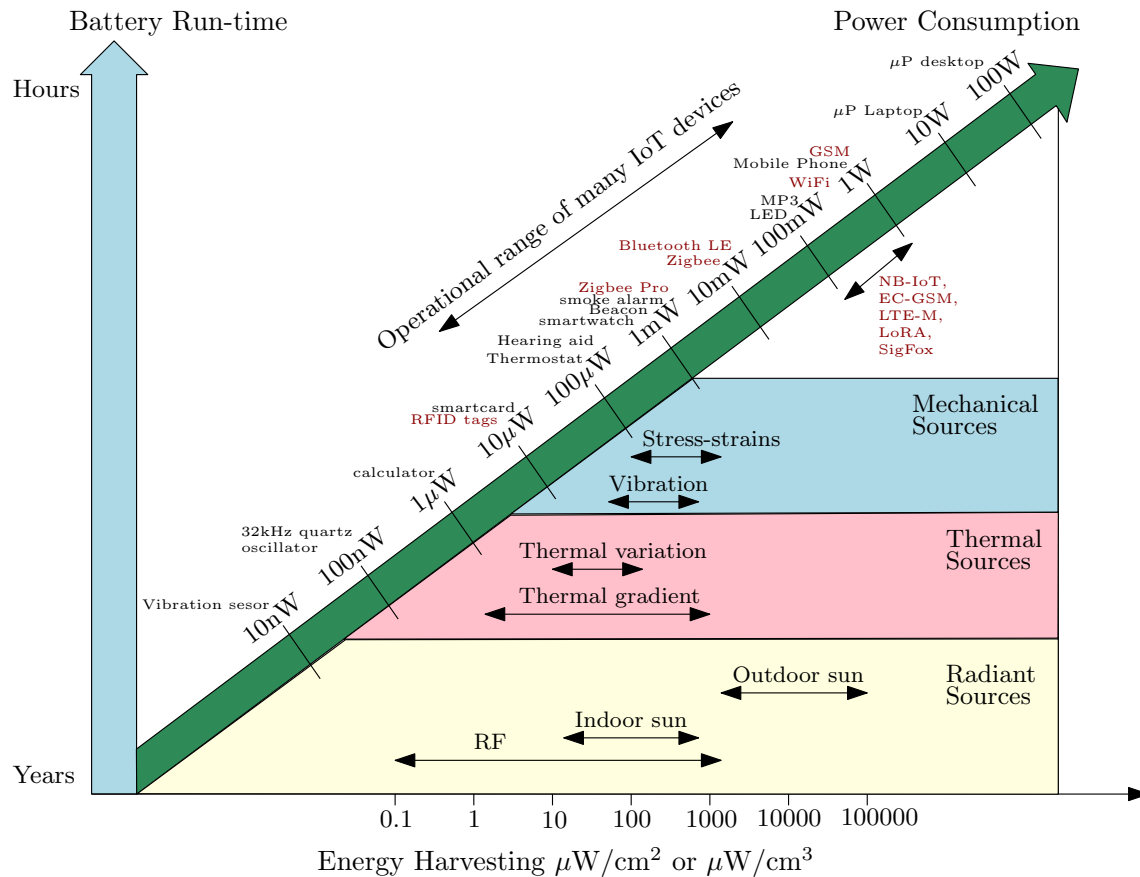

Fig. 8. Power consumption for various applications and power densities for various energy sources (data obtained from [38]). Power requirement for wireless technologies.

thermoelectric and vibration sources, was studied in [44]. Energy harvesting using piezoelectric and inductive devices was also proposed to monitor the health of a real railroad track in [45]. Another example where energy harvesting is crucial is body sensor networks, where the sensors are required to harvest energy for autonomous operation [46]–[49].

Second, energy harvesting can be used in applications which usually require too many devices and replacing their batteries is almost impossible or cost ineffective. Examples include electronic shelf labeling [50], body sensor networks, and massive IoT applications.

Third, in many applications there is no steady supply of electricity available. An example was discussed in [51], where energy harvesting was used in an agricultural setting to enable a delay tolerant wireless sensor network.

In many IoT applications, such as smart home or smart offices, intelligence transportation systems, smart grids, and industrial monitoring, a large number of devices will be installed everywhere, sometimes in hard-to-reach areas. These devices will be the major consumer of energy in near future due to the rapid growth of their numbers, and the use of energy harvesting will decrease our dependencies on fossil fuels and other traditional energy sources which are depleting very fast. Energy harvesting can also promote environment-friendly, clean technology that saves energy and reduces CO₂ emissions, which is a promising solution for achieving the next

generation smart city and sustainable society [39].

On the other hand, energy harvesting could save lots of energy in a wider scope, as it could hugely reduce the cost of modifications in the buildings and industries for wiring and maintenances. Energy rich environment, such as industries and vehicles, must be capitalized on this available energy, where the small amounts of energy from the environment would be sufficient to run sensor nodes. Advanced sensing techniques in industries will significantly increase the performance and competitiveness, as constant monitoring through embedded devices reduces the cost and energy consumption associated with system failure and maintenance [52]. This however cannot be achieved if the system requires cables or if the battery have to be regularly replaced [53], [54]. Wireless solutions and energy harvesting techniques provide a wide range of solutions for the sensors to become maintenance free. Some examples are the use of piezoelectric energy harvesters for vibration monitoring [55], solar energy harvesting for autonomous field sensors [56], and recently proposed multi-source energy harvester strategies for wireless sensor networks [57].

Fig. 8 shows power requirements of different applications and the power densities for various energy sources. As can be seen selecting the energy source for IoT applications, depends mainly on the application and the specific requirements of that. Silicon Lab [58] has recently identified 5 fundamental considerations for powering wireless IoT sensor products. These

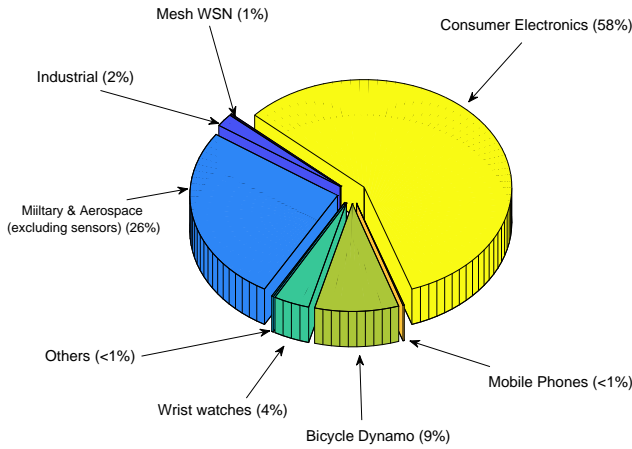

Fig. 9. Energy harvesting market 2011 [59].

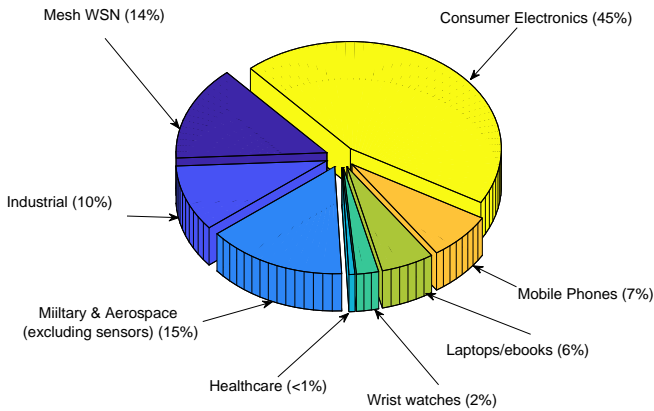

Fig. 10. Energy harvesting market 2017 [59].

include, 1) the target market and its specific requirements on cost, reliability, and network lifetime, 2) energy efficiency and the choice of wireless connectivity, 3) the required transmission strength, duration and duty-cycle between active and sleep states, 4) the sensor node and its power requirement and cost, and 5) the space constraints and storage energy.

D. Energy Harvesting Market Perspective

The global energy harvesting market reached \$880 million in 2014 and \$1.1 billion in 2015 and will continue to grow to \$4.4 billion by 2021 [60]. Fig. 9 and Fig. 10 show the energy harvesting market in 2011 and 2017, respectively. Consumer electronics cover the maximum share of the global EH market.

As shown in Fig. 9 and Fig. 10, Industrial and WSNs experience the fastest growth amongst energy harvesting sectors [61]. This is due to the vast deployment of miniaturized devices for industrial automation and monitoring, structural health monitoring, environmental monitoring, and home automation. In other words, the wide adoption of energy harvesting techniques in IoT applications has increased the share of EH market for IoT related sectors, such as industrial and WSNs. It is also important to note that the share of healthcare in EH

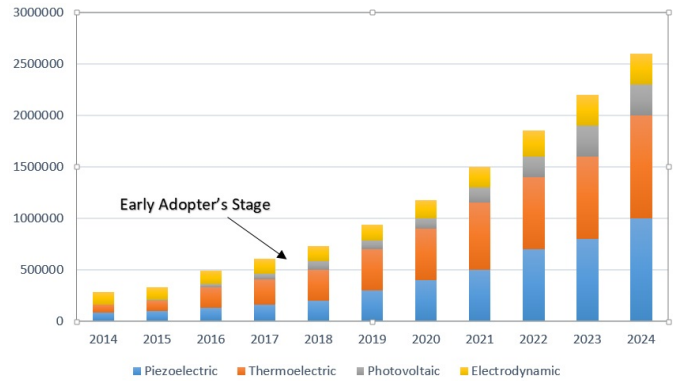

Fig. 11. Global energy harvesting market [59].

market is expected to grow very rapidly due to the popularity of IoT applications in helathcare.

The market for the piezoelectric energy harvesting is expected to grow significantly which is due to the highest reliability, efficiency and power output by size and cost offered by the piezoelectric energy devices harvesters against the other energy harvesting technologies (see Fig. 11, t). The market for industrial applications of piezoelectric energy harvesting is growing significantly due to its wide applications in oil and gas manufacturing, and more generally in industrial environments, where piezoelectric energy harvesting offers a cost-effective alternative to expensive wired infrastructure. Asia Pacific and North American countries are expected to show higher growth in the piezoelectric energy harvesting market over the forecast period [62].

The piezoelectric market can be segmented as industrial switches, consumer electronics, aerospace, healthcare, electronic locks, lighters and other electrical, military, pavements, roads, and railroads, push-button industrial sensors, remote controls, toys and gadgets, and vehicle sensors. Due to potential of piezoelectric nanogenerators for high-tech applications, fabrication of hybrid piezoelectric materials in fiber and powder form open new windows to overcome challenges associate with applying non-flexible materials in this field [63].

One of the main potential use cases of piezoelectric materials is in structural health monitoring. Tiny devices are installed in the structures, such as buildings, bridges, airplanes, and they are expected to continuously work for several years. Powering these devices with batteries is almost impossible as battery replacement is sometime impossible as the devices are out of reach. Battery replacement is not cost-effective and also battery size may be an issue in these applications. Piezoelectric materials provides an unlimited source of energy for these sensors, as structures are rich environments of vibrations. Piezoelectric actuators can be designed in different shapes and sizes; therefore has the potential to lift IoT technologies in structural health monitoring. healthcare industry is also considered as one of the main potential targets for piezoelectric materials. Implanted devices can be powered by piezoelectric materials instead of batteries, to increase the lifetime of these devices and make them comfortable for the patients. Wearable sensors, such as smart watches and fitness trackers, can be also powered by piezoelectric materials to convert human body motion into electricity to perform measurements and wireless

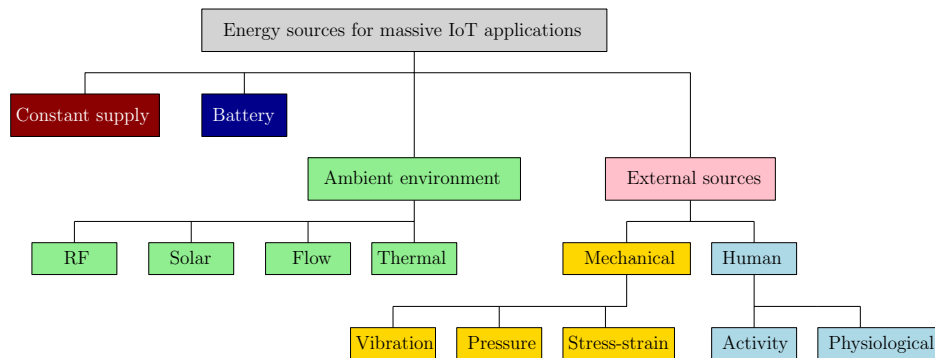

Fig. 12. Energy sources for IoT applications.

communication with personal devices.

Some of the key players in the piezoelectric energy harvesting market include Advanced Cerametrics, Boeing, Honeywell, ITT, Microstrain, Inc., Smart Material Corp., and Tokyo Institute of Technology [62]. As reported by IDTechEx, about \$145 million in 2018 will be spent on piezoelectric energy harvesting and by 2022 it will create a market of \$667 million [64].

IV. POWERING THE INTERNET OF THINGS

Fig. 12 shows the taxonomy of energy sources for IoT devices. They can be mainly categorized into four groups. The first and second groups are respectively main power and battery. The third group is the ambient environment, where the energy is harvested from the environment through solar, thermal, wind, and RF signal energy. The fourth group is the external sources, where the energy is extracted from mechanical movements or from the human body. It is important to note that an energy source may be categorized under different categories depending on the application. For example, mechanical vibration may be considered as an energy source from the ambient environment, when the sensors are attached to vibration-rich environment structures such as bridges. In this section, we review different energy sources for massive IoT applications, present their pros and cons, and the applications where they can be used.

A. Main Power

The devices in IoT, may be connected to a wired power supply. This is more suitable for IoT applications with fixed-location devices, where a constant power supply can be connected to the device through wires or cables. This however makes the devices immobile, which limits its application in massive IoT. Moreover, it is impractical to connect every device to the power supply through wires when the number of devices is very large. This option is only feasible when the number of devices is very small, and due to specific requirements of the devices is the only way to power the devices. Examples include video surveillance and monitoring applications, where a specific area is constantly monitored by a few high-quality cameras and the data is continuously sent to the security units. Another major application is smart

appliances, which are placed in fixed-locations in homes, so they can be connected to the main power.

B. Battery and Super-capacitors

Battery is the most common energy source which has been widely used in our everyday devices. The stored energy in batteries however is limited, therefore the battery-driven systems have a finite lifetime. It is also difficult and costly to regularly maintain and replace batteries especially when the nodes are remotely located or the number of nodes is very large. These are the main problems of battery-driven systems, which limit the use of batteries in some massive IoT applications.

There are two major approaches to solve these problems for IoT systems. First, one could consider higher battery capacity. But this indeed implies increased cost, which is of course not suitable for massive IoT applications. Second, low-duty cycle operation modes can be used to extend battery life time. This has been recently considered in the recent standards for cellular IoT applications, including LTE-M and NB-IoT [65], where the battery life-time was shown to extend to up to 10 years by introducing new duty-cycle operation modes to traditional LTE standard. Further modifications in the transmission have been considered in these standards, such as lower data rates, lower transmit peak power, and half-duplexing, to minimize energy wastage and optimize battery usage [65].

Table I shows different battery technologies which are commonly used and their respective efficiencies. Lithium batteries are the most efficient batteries which have the highest power densities and efficiencies which can provide higher battery lifetime, suitable for some IoT applications. However, massive IoT applications require the devices to be tiny and autonomous, which put strict limitations on the energy storage and power management of IoT devices. These make the batteries not viable solutions for them [37]. Non-rechargeable batteries cannot be solely used for many IoT applications due to ecological implications and the fact that they have only limited storage [37], [66]. Imprint Energy [67] developed 3D printed Zinc rechargeable batteries were developed by for powering IoT devices, which do not require heavy installation and can be formed into any shape; allowing for customized applications. These batteries are slim and flexible

TABLE I
DIFFERENT BATTERY TECHNOLOGIES AND THEIR EFFICIENCIES
[69]–[74].

Battery type	Nominal voltage (V)	Weight Density (Wh/kg)	Energy	Self-discharging rate level
SLA	6	26	high	high
NiCd	1.2	42	low	low
NiMH	1.2	100	high	high
Li-ion	3.7	165	Low	Low
Li-polymer	3.7	156	Low	Low
Li-MnO ₂	3	280	Low	Low
Li-(CF) _x	3	360~500	High	High
Li-FeS ₂	1.4~1.6	297	Very Low	Very Low
Li-SOCl ₂	3.5	500~700	Low	Low
BrCl, Li-BCX	3.7~3.8	350	Low	Low
Li-SO ₂ Cl ₂	3.7	330	Low	Low
Li-SO ₂	2.85	250	Low	Low
Li-I ₂	2.8	330	Low	Low

and customizations ensures the required capacity and voltage to avoid extra power conditioning [37]. Another solution which has low power density and high energy density is solid-state thin-film batteries suitable for long-term deployment of IoT devices. The flexibility of these batteries and the fact that they can be manufactured in IC packages have made them suitable candidates for many IoT applications that target low cost and ting device implementation [68]. Super-capacitors have been also considered to replace rechargeable batteries, which have unlimited charge-discharge cycle, but suffer from high self-discharge (up to 20% per day) [37].

Amongst those Lithium batteries shown in Table I, a popular battery for the IoT applications is Lithium Thionyl Chloride (Li-SOCl₂) battery. The features of this type of battery include long lifespan with low self-discharge rates, and most importantly the highest energy density comparing with other types of Lithium batteries. However, the battery charging techniques for this type of battery are tough due to the high output resistance of it and limited output current. Moreover, the energy efficient scheme often optimises the electronic circuit such that the batteries of IoT devices would be capable to burst to wake up and stabilise the voltage of the devices in a tiny time slot. But this operation would not only sag down the voltage of Lithium Thionyl Chloride battery but also reduce its lifespan.

Battery storage is a mature technology when compared with energy harvesting technologies, and the fact that batteries are available in different sizes and shapes, make them strong candidate for many massive IoT applications, which are expected to operate with ultra-low power and have limited life time, up to 10 years. Therefore, the battery technology still plays an important role in the IoT ecosystem for many years. The unique requirements of many IoT applications, open new challenges for battery providers.

C. RF Energy

In RF energy harvesting, the electricity is generated as a result of magnetic inductive coupling effect [75]. It is basically based on the induction of an open circuit voltage around the receive loop from a loop which carries a time varying current. The flux and the open-circuit voltage are mainly determined by the distance between the turns of the loops, the amplitude of the transmit loop current, and the dimension and distance between the loops [75]. The induced voltage at the receive

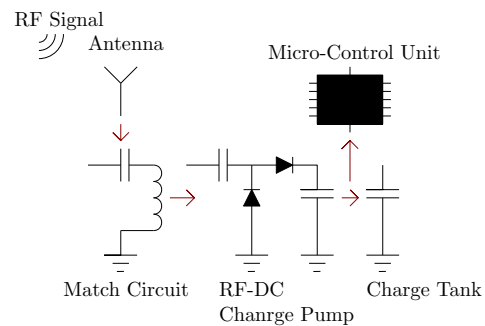

Fig. 13. RF energy harvesting circuit [78].

loop can be used to power a passive RFID tag or stored in a rechargeable battery.

Currently, we use this technology in electronic ID tags and smart cards, which are embedded with passive electronic devices and will be triggered when they are exposed to nearby energy rich sources which are transmitting RF signals. Considering the vast deployment of the devices in massive IoT, this solution may not be scalable as the environment needs to be flooded with RF radiation to power the nodes. Such radiations of RF signals would probably presents health risks for human beings.

Wireless energy harvesting (WEH) has been considered for powering IoT devices in [76] and improvements in terms of being wireless, availability of the RF energy, low cost and relatively easy implementation were shown. Sensor nodes which are powered by WEH usually consist of a transceiver and antenna element, a WEH unit which is responsible for scavenging RF energy and delivering a stable output power, a power management unit, and possibly an onboard battery (see Fig. 13). Recently, Freevolt proposed an innovative technology, called Low Energy Internet of Things (LE-IoT) devices, which can harvest RF energy from both short-range and cellular wireless networks, such 4G, WiFi and Digital TV [77].

Washington University [79] has developed a novel communication system Wi-Fi Backscatter, which aims to establish Internet connectivity for the IoT RF-powered devices. Nonetheless, the energy harvested from the RF signals is far less comparing with many harvesters that based on other energy sources. Therefore, the scalability of this type of harvesters is limited and these would be more suitable for powering auxiliary devices like Wi-Fi Backscatter.

Another emerging technology that enables the RF energy harvesting is using metamaterials instead of antennas. The concept of metamaterial is to use an architecture consists of many small-sized elements to manipulate the electromagnetic waves. This array of all elements called metamaterial which can be engineered and designed to behave very different compared to other known materials. For instance, a metamaterial can be designed to have a very high absorption coefficient and very low transmission and reflection coefficients. This leads to higher conversion efficiencies for metamaterial energy harvesters. In [80], an RF energy harvester was designed for 900MHz frequency consists of 5 elements reaching the efficiency of 36% at 70Ω load. The unique characteristics of metamaterials made them very attractive for scavenging energy from high frequency electromagnetic waves, optical beams and

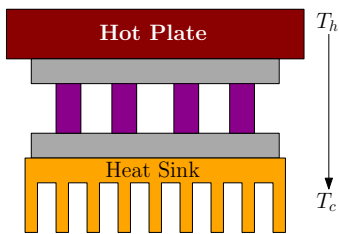

Fig. 14. Thermal energy generator.

even acoustic waves [81].

We will discuss about challenges and future research directions in RF energy harvesting in Section VI.

D. Thermal energy

A thermal energy generator (TEG) converts temperature differences into electrical energy. A TEG usually suffers from low efficiency (5-10%) which limits its widespread adoption [82], [83]. However it has a long life cycle and stationary parts. To extract the energy from a thermal source, a thermal difference is required (see Fig. 14); e.g, 30 degree difference in the temperature of hot and cold surfaces of the device in the room temperature, results in only up to 10% conversion efficiency [84].

As shown in [85], about $22 \mu\text{W}$ can be harvested from a human body which was used to derive a Seiko thermic wrist watch and charge a lithium-ion battery. Authors in [82], [86], [87] showed that efficiencies more than 10% can be achieved by using new thermoelectric materials and efficient modules. It was also shown that the power density can be scaled by the square of the temperature difference [88], which makes thermal energy harvesting more suitable for environments with large temperature differences, such as buildings with heaters.

In [89], a comparison between different thermal energy harvesting devices was provided and it was shown that 150 mW, 100 mW, and 0.026 mW thermal power can be harvested for room heater at 34 degree temperature difference [85], Flex thermal EH for 6 degree temperature difference [90], and wearable thermal EH for 6 degree temperature difference [91]. This study shows that existing commercial thermal energy generators are not sufficient at a low difference of temperature. Lead Zirconate Titanate (PZT) and Poly-Vinylidene Fluoride (PVDF) films were also used to develop pyroelectric cells to power low power RF transmitters; however, low efficiency was observed in these applications [92]–[94].

E. Solar and Photovoltaic Energy

Photovoltaic (PV) is considered as one of the most effective EH techniques to power IoT devices due to its power density, efficiency, and the flexibility in terms of different output voltage and current [95], [96]. When sunlight is directed to certain semiconductor materials, solar energy will be converted into DC power. This is called the photovoltaic (PV) effect. A solar cell is usually composed of silicon and when it is stroke by sunlight with enough energy, the electron and holes are separated and using an input an output regulator, electrons start to move towards the load [89]. To control the charging current to a battery or super-capacitor a maximum power point

tracking (MPPT) unit is necessary, which also maximize the efficiency of the PV cells.

Outdoor environments are exposed to sunlight and are generally more appropriate for PV energy harvesting [89], where for a typical outdoor illumination level of 500 W/m^2 , efficiencies of 15% to 25% can be achieved using polycrystalline and amorphous silicon cells [97]. Other indoor environments such as hospitals and stadiums can also benefit from this technology as they have many lightings. Authors in [97] reported PV energy efficiencies of 2% to 10% for indoor applications at illumination level of 10 W/m^2 .

Jiangtao et al. [98] proposed bidirectional visible light communication (VLC) technology named Retro-VLC, that enables battery-free IoT applications. The main ideas here include the low-power optimisation techniques, the bidirectional communication which is established on the shared light carrier between the uplink and the downlink and battery-free realised by energy harvesting utilising Photovoltaic cells. The implemented physical system essentially consists of a reader and a tag, which are integrated in the lighting infrastructure and IoT devices respectively. According to the circuit diagram, the receiving circuit of the tag, or ViTag-RX, contains light sensor that captures incoming light signals, amplifier that amplifies those signals, demodulator and comparator that demodulate and digitise the analog signals for later decoding in the microcontroller. On the other hand, the transmitting circuit of the ViTag, or ViTag-TX, includes the aforementioned microcontroller and a LCD driver that encodes and transmits the signals respectively. This design enables battery-free IoT applications with ultra-low power consumption that only a 12W bulb on the upstream (ViReader) is enough to power the downstream (ViTag) circuit. However, the range of this technology is very limited, that the maximum continuous effective working range is only around 2.5 meters according to their tests, which limit the scalability of this design. Moreover, the requirements on interference is highly restricted. Nonetheless, this design is still desirable for many IoT applications such as smart home IoT, intelligent traffic systems IoT, etc.

There are several problems with solar and PV energy harvesting technologies, which make them not suitable for the wide adoption in many IoT applications. First of all, the solar panel must receive enough light to be able to generate enough power for the device. Therefore, when there is no light or the light intensity is low and varying, the PV energy cannot be properly harvested and used. Second, to harvest solar or PV energy, a relatively large (compared to the device size) PV cell must be installed to harvest enough energy, even if the light intensity is large. This is maybe the biggest issue with the PV energy harvesting which limits its application in massive IoT, which mainly require tiny devices to be installed in different places, regardless of the light intensity. Third, when the light intensity is varying, a battery must be also considered to store energy and provide that energy to the device, when the light intensity is low. This is quite common in applications which are powered by solar cells, where the energy is stored in batteries during the day and then used at night for different applications.

F. Mechanical Energy

As shown in Fig. 12, electrical energy can be harvested from vibrations, pressure and stress-strain. Electromagnetic, electrostatic, and piezoelectric are three main mechanisms to generate electricity from mechanical sources [89]. In electromagnetic energy harvesting, the electric current is generated when a magnet moves across a coil. In piezoelectric materials, an electric potential is induced at the terminals of a piezoelectric material due to the polarization of ions in the crystal as a result of the strain. In electrostatic converters, the plates of a charged capacitor are pulled using the vibration, which then results in electrical energy due to the change in the capacitance. Piezoelectric energy harvesters has the highest energy density, that is higher energy can be produced for a given surface area, which is very important in micro scales, where most IoT devices are supposed to operate. Electrostatic mechanism requires separates voltage source and electromagnetic usually generate low voltages.

in [99], vibrational energy harvesting was used to power wireless sensors attached to the bridge, where the vibrations from the passing traffic on a bridge was used to generate electricity using linear electromagnetic generators. Electrostatic micro generators were also suggested in [100], where about 50 μW energy can be harvested from 0.1cm² surface area. Also in [101] a peak power of 3.25V was reported to be delivered for an electromagnetic transducer at the mechanical resonate frequency of 10.4Hz.

The authors in [84] have categorized the mechanical sources into, steady state sources, intermittent sources, human and machine motion, and Gyroscopic motion. The vibration source in steady state mechanical sources are based on the constant flow/motion of a liquid/object in either natural channel or pipes. This energy sources are usually used to generate electrical energy on a macro scale. However, similar concepts can be used to harvest energy on a micro scale, for example using blood flow and inhalation/exhalation in human to harvest energy as reported in [102]. Intermittent mechanical sources on the other hand are not steady and usually require an external object to trigger an event and thus produce the mechanical vibration. For example, the energy can be harvested from human activities such as walking, sitting, and sleeping [84]. Human body is considered as a mechanically-rich environment where different motions and forces can be effectively converted to power wireless devices. A comprehensive summary of the human-based energy harvesting systems was presented in [84].

We will provide more details on vibrational energy harvesting based on piezoelectric materials in the next section, where we explain the basic concept, the available piezoelectric materials and their characteristics, and a brief explanation of the newly developed material with high electrical properties.

G. Biofuels and Biobatteries

Biofuel cells has introduced a promising alternative source of sustainable electrical energy. These cells are working based on bio catalyzed chemical reactions to change chemical energy into electricity. Biofuel cells can be implanted in living organisms as micro-power sources, however, providing the

adequate amount of voltage and connectivity of such cells to the electronic devices has been intriguing for researchers.

In [103], it is reported that electrical energy has been extracted from implanted biofuel cell in lobsters body. Enzyme modified electrodes in a living lobster results producing electricity by biocatalytic oxidation of glucose and reduction of oxygen inside the body. Most biofuel cells can provide an open circuit voltage of 0.5V which is subject to deduction by drawing current from the cell. The low voltage problem can be addressed by two approaches: (i) assembling cells in series electrically (ii) collecting the produced energy in a capacitor and then release it as pulse.

Implantable biofuel cell can be used to power many IoT devices. Environmental monitoring applications where micro-electronic devices sense and send data wirelessly, or wireless transmitting devices can be carried by animals while taking energy from implanted biofuel cells in their body. More importantly, it can be widely used in biomedical applications, where the energy can be taken from human body to power implanted devices, e.g. pacemakers, eliminating the need for batteries. Millions of patients using implanted pacemaker suffer from the necessary surgeries for replacing batteries. The risk and cost of frequent surgeries can be mitigated by serving an implanted biofuel cell providing energy as long as the patient is alive.

H. Human Body

Human body is considered as a rich environment to scavenge energy to power wearable electronics [102], [104]. Wearable devices are very important in health monitoring applications, where sensor nodes are deployed on or implanted inside the human body, which form a network called wireless body are network (WBAN). As the battery replacement for wearable devices is inconvenient for people and sometimes impossible in cases when the devices are deployed inside the human body, the sensor nodes in WBAN must have very long lifetime. Therefore, energy harvesting from human body is favorable in these applications [89].

The power scavenging techniques from human body can be generally categorized to passive and active techniques. In passive human powered devices, the energy is harvested from normal activities of a person, such as orthopedic implants [105], motion of the heart, lungs and diaphragm [106]. In active energy harvesting, the person needs to perform some special activities or power generating motions. Flashlights which are powered by squeezing a lever is an example of active human powered devices [107]. As these activities may not be convenient, active human powering is not very practical for IoT applications, where the data is sent seamlessly and sometimes randomly to the server.

All the aforementioned energy harvesting techniques can be used to harvest energy from the human body. The main challenge is then to miniaturize them for the ease of human adoption [89]. A summary of potential WBAN energy sources was provided in [8]. The human body energy sources can be divided into two main categories: biochemical and biomechanical [8]. Biochemical sources include Glucose [108], Lactate [109], Potential hydrogen [110], and Endocochlear

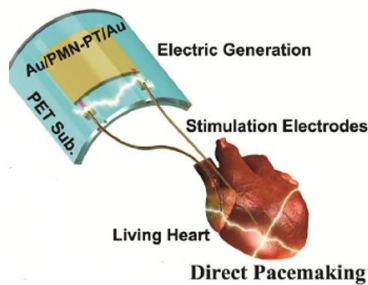

Fig. 15. Implanting integrated PMN-PT energy harvesting device and a pacemaker on the living heart [117].

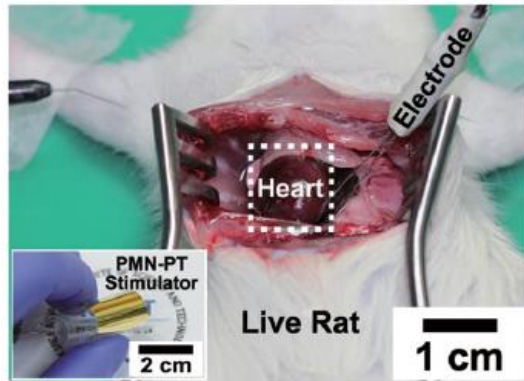

Fig. 16. Medical experiment on a living rat to verify the harvesting device [117].

potential [111], and biomechanical sources include heartbeat [112], blood pressure [113], breathing [106], and voluntary locomotion [8]. For example, in [102], [114] the energy was harvested during heel strike and in the bending of the ball of the foot using piezoelectric materials and also in [115], [116] the energy harvested from piezoelectric shoe insert was used to power RFIC tags. A summary of different applications and use cases of piezoelectric energy harvesting for wearable biosensors was provided in [107].

Artificial cardiac pacemaker is a device which can be implanted in human body to regulate the heartbeat using electrical impulses. This device is vital for people who suffer from sick sinus syndrome which causes abnormal heart rate. So far, batteries were the only options to power such implantable devices, however, limited lifespan of the batteries have made the surgical replacement inevitable. The replacement period can be as short as 3 to 6 years, which can be very harmful for probable infection or bleeding during surgery.

Many research works have been conducted to harvest energy from piezoelectric materials to supply the power required by pacemaker. For example, using different types of piezoelectric materials such as BaTiO_3 thin film [118] and lead Zirconate Titanate (PZT) [119] thin films have been used as flexible energy harvester to be installed on heart tissues for converting mechanical stress to electrical energy. However, their output current hardly exceeds a few micro amperes and therefore, they were not operable in powering a cardiac pacemaker which needs inputs of $100\mu\text{A}$ and 3V . In [117] a new approach to make self-powered artificial pacemaker has been reported which can supply maximum current and

voltage as $145\mu\text{A}$ and 8.2V respectively. By installing such device on a moving tissue, i.e. heart muscle Fig. 15, it can produce enough energy to supply implantable devices in body. As shown in Fig. 16, it is successfully implanted on a live rat to verify the output rate, where approximately 133.9W of energy was generated by kinetic energy from an adult. This amount of energy is a good source to power wearable sensors and personal services such as tracker, GPS, health care devices, etc.

I. A Brief Comparison between different Energy Harvesting Techniques for IoT

In Table II, we have briefly compared different energy harvesting techniques. Energy harvesting from environment is usually uncontrolled and unpredictable and in most cases the conversion efficiency is low. PV cells provides high power density, but they require constant exposure to light which limits their application in many IoT use cases. Temperature based energy harvesting is very limited and can be useful when high temperature difference is guaranteed. RF energy harvesting is also limited due to low efficiency in indoor environment and also in case of multipath. On the other side, mechanical energy harvesting, especially piezoelectric EH can achieve high power densities which is suitable for IoT applications where mechanical vibrations is constantly available.

In the rest of the paper, we will focus on vibrational energy harvesting and RF-based energy harvesting as promising solutions for massive IoT applications. Piezoelectric materials show high power density and recent technological advancements in developing new materials with enhances electrical properties make them very attractive energy sources for the Internet of things applications in vibration-rich environments.

V. PIEZOELECTRIC ENERGY HARVESTING

Piezoelectric energy harvesters provide the consistent source of energy and the potential of generating electricity from piezoelectric energy harvesters is higher than alternative energy harvesting technologies. In this section, we study piezoelectric phenomena to be able to compare existing piezoelectric materials in the market. Piezoelectric materials can be optimized based on the intended application, to deliver the required level of voltage or current, and can be manufactured in any shape or size.

A. The Piezoelectric Phenomena

The Heckman diagram shown in Fig. 17 provides an overview of the interactions between mechanical, thermal and electrical properties of solids [120], [121]. A pair of coupled effects is joined by a line, indicating that a small change in one of the variables produces a corresponding change in the other. We are interested in the interaction between the elastic and electrical variables, which is separated by the dashed ellipsoid in Fig. 17.

In 1880, Pierre and Jacques Curie measured surface charges that appeared on crystals of tourmaline, quartz, topaz, cane

TABLE II
ENERGY SOURCES AND THEIR ENERGY HARVESTING POTENTIAL [84].

Energy source	Classification	Power density	Weakness	Strength
Solar power	Radiant energy	100mW/cm ³	Require exposure to light, low efficiency for indoor devices	Can use without limit
RF waves	Radiant energy	0.02 mW/cm ² at 5km	Low efficiency for indoor	Limitless use
RF energy	Radiant energy	40 mW/cm ² at 10m	Low efficiency for out of line of sight	Limitless use
Body heat	Thermal energy	60 mW/cm ² at 5°C	Available only for high temperature difference	Easy to build using thermocouple
External heat	Thermal energy	135 mW/cm ² at 10°C	Available only for high temperature difference	Easy to build using thermocouple
Body motion	Mechanical energy	800 mW/cm ³	Dependent on motion	High power density, not limited on interior and exterior
Blood flow	Mechanical energy	0.93W at 100mmHg	Energy conversion efficiency is low	High power density, not limited on interior and exterior
Air flow	Mechanical energy	177 mW/cm ³	Low efficiency for indoor	High power density
Vibration	Mechanical energy	4 mW/cm ³	Has to exist at surrounding	High power density, not limited on interior and exterior
Piezoelectric	Mechanical energy	50 mJ/N	Has to exist at surrounding	High power density, not limited on interior and exterior

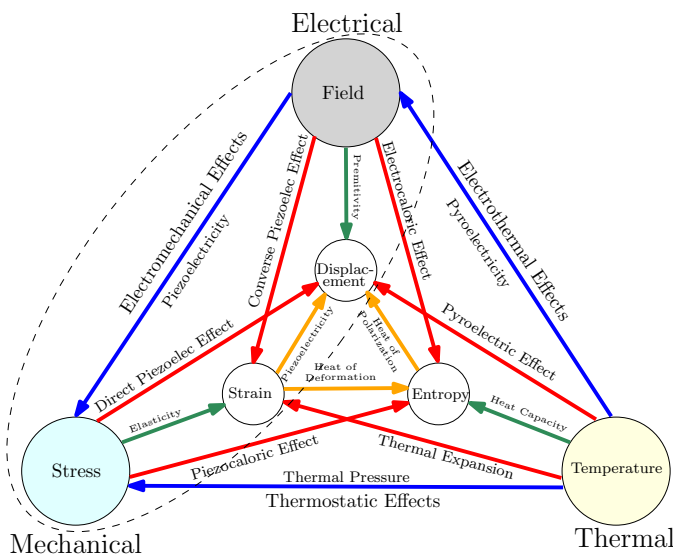

Fig. 17. A Heckman diagram representing the interrelationship between mechanical, thermal and electrical properties of materials [120].

sugar and Rochelle salt when they were subjected to an external mechanical stress, which is called the direct piezoelectric effect. In 1882, the inverse piezoelectric effect was confirmed by Jacques Curie, where the strain S was observed in response to an applied electric field of strength E . Fig. 18 shows direct and reverse piezoelectric effects. Piezoelectric materials show a small dimensional changes when exposed to an electric field, while some materials exhibit a reverse behaviour such that an electric polarization occurred when they are mechanically strained.

Direct piezoelectric effect is being considered as the main approach for harvesting energy from vibrations, where the external vibrations causes electrical charge on the terminal of the piezoelectric material [122]. The *monocrystal* and *polycrystalline* structure of same materials can be used to explain the piezoelectricity concept. As shown in Fig. 19-a the polar axes of all carriers are aligned in the same direction in a monocrystal. In polycrystal (Fig. 19-b) however, different regions within the material have different polar axes. The piezoelectric effect can be obtained by heating the polycrystal to the Curie point and then applying at a same time a strong

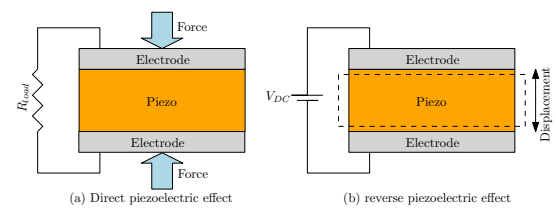

Fig. 18. Direct and reverse piezoelectric effects.

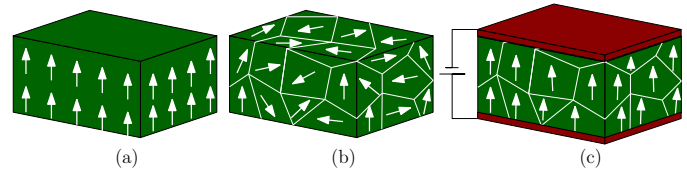

Fig. 19. Different polarization in crystals. (a) Monocrystal, (b) Polycrystal, and (c) Polarization.

electric field. The molecules can then move freely due to the heat which results in the re-arrangement of the dipoles due to the external field (Fig. 19-c). When the material is compressed, a voltage will appear between electrodes. The opposite polarity appears when the material is stretched (i.e., direct piezoelectric effect). On the other hand, when a voltage difference is applied the material will be deformed, and the material will vibrate when an AC signal is applied [123].

There are several figure of merit (FoM) for piezoelectric energy harvesting, but we only discuss about the power density which is more relevant to our topic. The power density, which is defined as the ratio of generated power over the active material volume or over the active material area. As shown in [107], the output power of a piezoelectric generator is proportional to the proof mass, the square of the acceleration magnitude of the driving vibrations, and inversely related to the frequency. As mentioned in [107], piezoelectric devices provide high voltages and low currents. However, using multiple layers of biomorphs, it is easy to design a system that produces voltages and currents in an appropriate range.

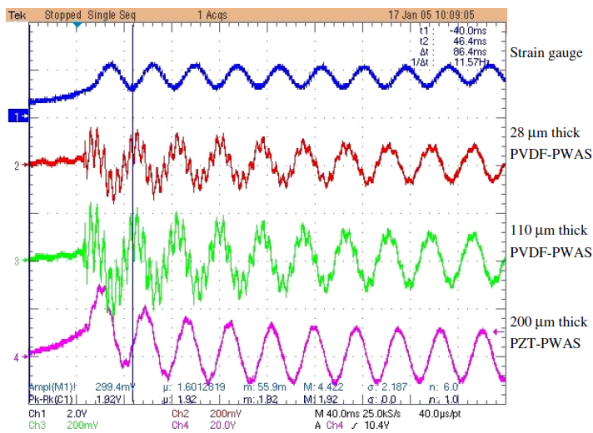

Fig. 20. Vibration signal recorded by strain gauge, PVDF-PWAS and PZT-PWAS [127].

B. Advancements in Piezoelectric Fabrication for Energy Harvesting

Various materials have been previously shown to demonstrate piezoelectric effect and used in several applications such as actuators, sensors, nanogenerators, atomic force microscopes (AFM), high voltage application, energy-harvesting devices, and medical applications. All of these technologies mainly rely on the mechanical energy harvesting [121]. A wide range of both natural and synthetic materials exhibit piezoelectricity. More than 200 piezoelectric materials are available now, where for each energy harvesting application a specific type can be used. Many biological tissues such as bone, intestine and tendon exhibit piezoelectricity. Some naturally occurring crystals, such as quartz, rochelle salt, cane sugar, topaz, sucrose are classified as natural piezoelectric materials. Lead zirconate titanate (PZT), zinc oxide (ZnO), barium titanate (BaTiO_3), gallium orthophosphate (GaPO_4), potassium niobate (KNbO_3), lead titanate (PbTiO_3), Lithium tantalate (LiTaO_3), langasite ($\text{La}_3\text{Ga}_5\text{SiO}_{14}$), sodium tungstate (Na_2WO_3) and PVDF are the main synthetic piezoelectric materials, which have been widely used.

Compared to crystals, PVDF piezo films offer wider frequency range, sensitivity and mechanical toughness. PZT is suitable for low-noise application, while PVDF is most suited to the high frequency and large bandwidth applications. In addition to this, due to structural and physical property and lower density of the PVDF ($1800\text{gr}/\text{cm}^3$ compared to $7600\text{gr}/\text{cm}^3$ for PZT) compared to PZT, PVDF is a preferred candidate for lightweight sensors with curved surfaces and tiny complex structure [124], [125]. Table III shows the comparison of piezoelectricity performance of ceramic and polymeric materials at different conditions.

In a research that carried out to compare the piezoelectricity of the PZT based and PVDF based sensors, the generated electric signals were recorded to analyse the frequency contents of the signals. The signals spectrum are shown in Fig. 20. As can be seen the first three natural frequencies are $f_1 = 29.7$ Hz, $f_2 = 181$ Hz, and $f_3 = 501$ Hz. As can be seen although PZT based sensor deliver higher voltages compared to PVDF based sensors, they are less responsive to the higher frequencies [127].

C. Design considerations for Piezoelectric-based EH-enabled IoT devices, Challenges, and Future Research Directions

We have conducted some research in the area of PVDF based piezoelectric materials. The primary focus has been on the investigation of fabrication methods for composite fibers and powder including nanomaterials. By changing the fabrication techniques, process parameters, starting materials, the piezoelectric, morphological, and mechanical performance of PVDF are completely varied. By tuning the process parameters, tailored PVDF fibres with the desired piezoelectric performance can be developed. To develop more efficient nanogenerator for energy harvesting from piezoelectric materials, we need to optimize the output performance to achieve a higher energy efficiency. In addition to piezoelectric performance, properties such as formability, corrosion/wear/fatigue resistance need to be considered in fabrication of flexible nanogenerators.

In what follows, we focus on the design considerations for piezoelectric energy harvesting IoT devices and provide some useful guidance in this regard. Some detailed design considerations for piezoelectric EH systems have been presented in [107].

1) *Unpredictable energy performance*: Energy harvesting from the environment is unpredictable; that is the amount of power which is produced in a particular time instance is random which makes it difficult to continuously deliver sufficient power to the device. Harvesting sources also have low energy potential and low conversion efficiency [128]. Therefore, there should be a power management module that balances the power generation with the power consumption. That is the load resistance should be chosen appropriately [107].

2) *Power budget*: Power budget [128] is the most important factor when discussing the available options for powering IoT devices. That is what is the required voltage and current for the IoT device? How these requirements are changing in different modes of operation, such as wake up, active, sleep or shut-down? As the largest power in IoT devices used when transitioning from deep sleep to active mode, the duty cycle or the update rate is also a crucial factor for choosing the right technique for powering the device. Minimizing the number of wake-up cycles and transmitting longer data bursts in each cycle is very important to increase the power efficiency [129].

3) *Physical Damage*: In a standard piezoelectric transducer which converts vibration to electricity, the printed-circuit boards of the electronics is subject to same vibration and can lead to premature failure. To avoid this, an accurate understanding of the generating environment, the power generated, and the time required, and the device power consumption and consumption time is required.

4) *Energy storage*: As the current and voltage levels generated from energy harvesting sources system are fairly low, the batteries and super-capacitors must be designed to charge effectively at low power levels. Leakage and internal drain must be minimized too [128]. As shown in [107], the size of the storage capacitor should be at least 100 times the capacitance of the piezoelectric device. There is a tradeoff

TABLE III
PERFORMANCE OF PIEZOELECTRIC MATERIALS AT DIFFERENT GEOMETRIES AND LOADING CONDITIONS [126].

Material	Ceramics				Polymers	
	ZnO	ZnO	PZT	PMN-PT	PVDF	P(VDF-TrFE)
Device Length (μm)	200	10	5	150	100-600	60
Diameter (nm)	4000	100	500	200-800	600-6500	200
Device area (mm^2)	N/A	225	6	50	N/A	157
V_{oc} (V)	0.035	35	0.7	6	0.01	3

between the required capacitance for the piezoelectric EH systems and the demand side [107].

5) *Power IC*: The power IC needs to carefully selected to match to the power generating element. That is the voltage/current/output characteristics of the power generating element output will differ according to the element, and it is necessary to choose a power IC that will provide optimal results [128].

6) *Output power*: In piezoelectric biomorphs, a dramatic fall in the output power is observed if there is a mismatch between the resonant frequency of the converter and that of the driving vibrations [107]. This has to be carefully considered when designing the IoT energy harvesting unit, so that the designed biomorph resonates at the frequency of the target vibrations. A magnets can be used to limit the vibrations of the device. However this solution is not viable as it adds bulk and cost and limits the broadband ability of the piezoelectric device. Pre-biasing the piezoelectric material is another approach to achieve a power gain up to 20 times.

7) *Oscillation proof mass*: The power output of piezoelectric materials is proportional to the oscillating proof mass. In order to increase the power output, the mass should be maximized by taking into account the space limitations and also the yield strain of the piezoelectric material [107].

8) *Operational bandwidth*: The output power of a piezoelectric energy harvester is inversely proportional to the bandwidth. The bandwidth is an important parameter when the piezoelectric harvesters is subject to unpredictable or uncontrollable ambient vibrations. The frequency of ambient vibrations is naturally uncontrollable, therefore narrow-bandwidth energy harvesters are impractical in most real applications.

Piezoelectric nanogenerators have not been widely used for massive IoT. The main reason is that the can provide electricity when there is enough mechanical vibration in the environment. The generated power is also unpredictable. However, they can be used as a supplementary technology to recharge the battery. The battery will remain the main supplier of energy to the device and the piezoelectric nanogenerator help recharging the battery. This is feasible for many IoT applications that have low data rate demand and perform very limited tasks. These devices can work with a single battery charge for 5-10 years and that is more than enough to harvest energy from the environment to keep charging the battery. The aim is to minimize the battery replacement and maintenance and piezoelectric nanogenerators are excellent options for this purpose.

These is no comprehensive study on the lifetime of IoT systems equipped with piezoelectric nanogenerators for battery recharging. Unlike the RF energy harvesting that the energy harvesting medium will interfere with the information transfer

medium which reduces the effective data rate, piezoelectric energy harvesting does not interfere with the information transfer and therefore does not limit the data rate. Further research in this area is required to better understand the dynamic of such systems so to be able to estimate the network lifetime and optimize the charging cycle of the device.

VI. RF ENERGY HARVESTING IN MASSIVE IoT: CHALLENGES AND FUTURE RESEARCH DIRECTION

EH techniques provide feasible power sources for a large number of small devices usually deployed in massive IoT scenarios. According to 3GPP, the massive IoT scenarios require low to moderate data rates with usually tolerable latency. The demand however is on the ultra low power consumption for extending the device and network lifetime.

Efficiency is a key factor for the RF energy harvesting system, where it is reported that higher efficiencies are achieved when higher power signals are transmitted. However, the maximum power should be limited to avoid health risks and also avoid interference on other networks. Recent developments of RF harvesting systems are reported to achieve efficiencies as high as 50% at sub-milliwatt power levels. Harvested energy from RF signals depends on the relevant distance between the transmitter-receiver pair, but the received energy is adversely affected in the presence of multipath and fading [130], [131].

There are several factors that may hamper the success of RF energy harvesting in IoT applications. The fact that the devices need to harvest wireless energy from the RF signal put restrictions on the network to constantly supply RF power to the device. This however increases the overall power consumption of the networks, especially at the base stations and dedicated RF generators (see Fig. 21). RF energy harvesting however is an interesting technique to serve a large number of IoT devices in massive IoT applications. In what follows we explain some major techniques for RF energy harvesting in massive IoT and discuss their challenges and future research directions.

A. Interference and Fairness

RF energy transfer can cause co-channel interference to the nodes in the network. To reduce the interference, interference management strategies should be developed. From the physical layer point of view, adaptive power control schemes can be useful to not only optimize the throughput, but also to improve the energy transfer efficiency. From the MAC layer perspective, dynamic multiple access techniques can be used to effectively schedule the data transmission and power transmission to avoid interference [132].

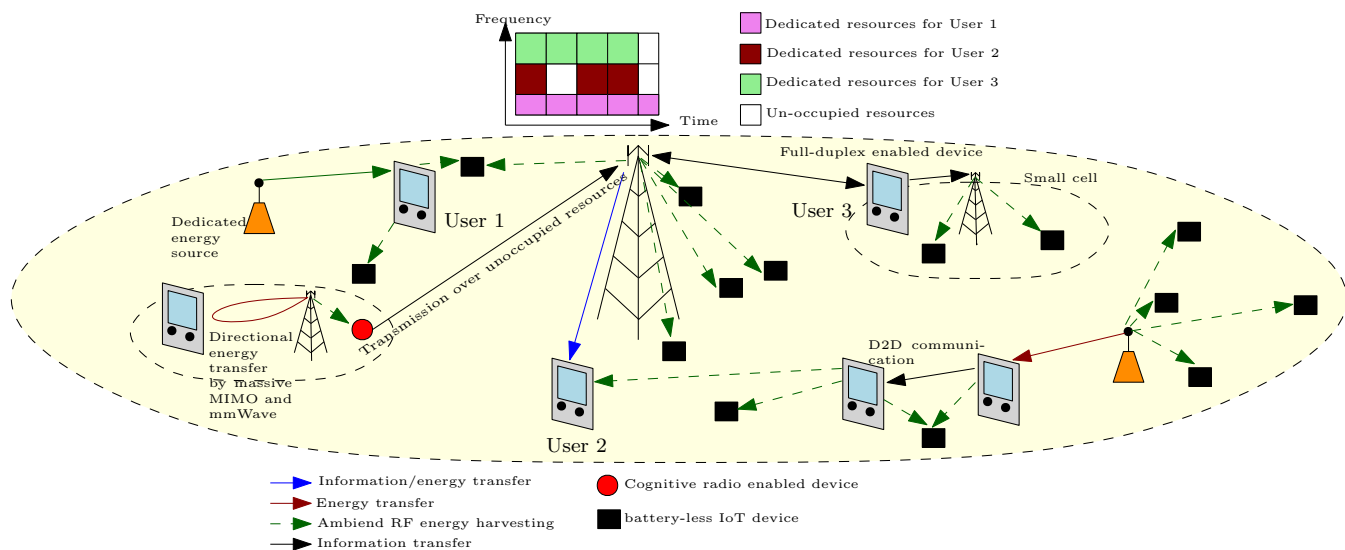

Fig. 21. RF-based energy harvesting in wireless cellular networks.

In massive IoT the interference problem become more challenging due to the large number of devices. There is still lack of fundamental studies on wirelessly powered massive IoT systems and most existing works tend to extend existing power management and multiple access techniques to these systems. Quality of service and device lifetime should be considered when designing RF-based IoT systems. Moreover, joint power control and multiple access and resource allocation should be considered to effectively minimize interference associated with RF energy harvesting.

In cellular based massive IoT systems, the cellular base station performs as the power beacon for IoT devices. More specifically, each time frame is divided into three time slots, namely *harvesting*, *downlink*, and *uplink* time slot. In the harvesting time slot, the base station send beacon signals, usually of higher power, so the devices can harvest energy. The same RF signal is sent to all devices and certainly those that are closer to the base station harvest more energy and it takes longer for cell-edge users to harvest enough energy. One cannot increase energy in such a way to charge the cell-edge users in one shot due to the maximum transmit power limit and the interference level. The base station also needs to perform a very complex resource allocation optimization to maximize the throughput. Stochastic geometry has been extensively used in the literature to analyse RF-enabled cellular IoT systems and provide insights on the system performance [133].

B. Energy and Radio Resource Management

RF energy harvesting has shown to be an effective approach to enable sustainable massive IoT systems. An IoT device may either harvest RF signal energy or decode the information via optimal switching rules. In such strategies, the device first harvest enough energy and then start transmitting/receiving information. This feature is very useful for massive IoT applications with bursty traffic. That is the device only reports the data upon receiving a request from the data centre/gateway. The device switches between two operation modes, namely

silent (or energy harvesting mode) and active (or data TX/RX mode). In many massive IoT applications, the device reports very infrequently which leaves enough time for the device to harvest enough energy from ambient RF signals. The harvested energy depend on the received signal strength and the time duration of the harvesting. The transmission range cannot be long as the IoT devices are usually low cost and have limited functionality.

For massive IoT there are two possible solutions to enable RF-based massive IoT systems. The first solution is to use a dedicated RF signal generator to beam the RF signal towards the devices and therefore harvest energy. The other solution is to harvest energy from ambient RF sources, like cellular, TV and WiFi signals. While this increase the system complexity as the RF harvesting circuit may need to work over a different spectrum and bandwidth, this solution has recently attracted interests for massive IoT. In fact, the devices harvest energy from ambient signals which are not intended for themselves. This scheme however is only feasible for short-distance and infrequent device-to-device communications.

Optimal strategies should be developed by jointly considering power control and resource allocation. Both systems level and per-user optimization should be considered for different IoT services, including delay sensitive and delay tolerant use cases.

C. User Mobility

In many IoT systems, the devices may be mobile and therefore their channel to the base station is constantly varying. This means that the harvesting node may not harvest enough energy due to the movement and therefore cannot send its data. The problem becomes more challenging when the device carries critical information with a strict latency requirement.

Most studies have focused on designing EH-enabled IoT systems where the devices have no mobility. In such scenarios, the system can be optimized to maximize the energy harvesting efficiency and network throughput. However, when the devices

are mobile, an additional factor will play a key role in the overall network performance. This factor is the outage due to insufficient energy at the devices. While this might be temporary, it might change the whole system dynamic that can lead to inefficient radio resource and power usage.

There is still a lack of comprehensive study on the dynamic of the IoT systems with mobile users powered by EH resources. RF-based energy harvesting seems a practical solution in mobile scenarios as the ambient RF energy is available everywhere. However, to maximize the systems performance the beamforming and radio resource allocation should be constantly updated due to changes in the channels. This will add extra communication overhead and accordingly extra energy consumption. Further research in this area is required to better understand the outage performance of RF-based IoT systems and develop novel low-complexity algorithms for dynamic optimization of power and radio resource allocation.

D. Cognitive-Radio (CR) Based IoT using EH Techniques

Cognitive radio (CR) technology enables devices to opportunistically access a spectrum primarily assigned to licensed users beforehand. Integrating RF-based energy harvesting with CR technology is of utmost importance which opens up new opportunities. It also creates many challenges which are different from traditional cognitive radio networks (CRNs).

In CR networks, a secondary user/device needs to sense the spectrum to find unused spectrum for its own utilization [134] (see Fig. 21). The sensing energy is an important factor that needs to be considered especially for low-power IoT devices which are operating with RF-based energy harvesting. Most existing works have neglected this energy in their proposed frameworks.

Another important aspect is the varying behaviour of the primary user. For example, User 2 in Fig. 21, may request for more data rate, therefore it occupies more radio resources. In this case the CR users (depicted by red circle in Fig. 21) need to wait more for finding unoccupied spectrum. The sensing process however is energy consuming and may deplete the battery very quickly, which might take long time to be recharged again by the ambient RF signal.

Secondary user may pose severe interference on the primary users due to the energy transfer phase for secondary users. What is clear though is that the primary users' transmissions is an opportunity for secondary users to harvest energy. However, secondary users' transmissions usually cause interference for primary users. Although several cooperative and non-cooperative strategies have been proposed to minimize the interference, these approaches mostly rely on the assumption that the user activities are known. For these cases and optimal sensing operation and time and power allocation can be derived.

Further research in this area is needed to better understand the dynamic of CR based EH-enabled IoT systems. Dynamic frame structure should be considered for these systems to be able to maximize the spectrum utilization and minimize the energy wastage due to unnecessary spectrum sensing by EH-based IoT devices. Power and radio resource management

should be optimized for more practical scenarios where the primary users' behaviour is changing. Statistical information of users activity should be taken into account to minimize the radio resource wastage and unnecessary spectrum sensing.

E. Heterogeneous Networks

In future cellular systems, there would be several layers of nodes, including macro and small base stations. While this makes the system more complex it brings many advantages, such as higher throughput and lower latency. In RF-enabled IoT systems this can be a useful feature of wireless networks as different layers are potential sources of RF energy. The design of multiple access and resource allocation in heterogeneous networks is challenging and require major investigation. The problem offers several interesting optimisations for power allocation, interference managements, and radio resource allocations.

Using multiple base stations with multiple antennas can significantly improve the overall system performance as it provides several energy sources for IoT devices. Multiple base stations can send power beacons at the same time, while the others operate over in the data TX/RX phases. Although the resource allocation will be more complex, the harvested energy will increase and the overall system throughput is expected to increase accordingly. This would be a feasible solution in 5G as a large number of small base stations are expected to be deployed by using small-cell technologies.

F. Massive MIMO and Millimetre Wave (mmWave) Communications

The RF signal used for energy harvesting should be kept at low power due to safety concerns. The efficiency of RF harvesting devices depend on the received power level and may vary from 0.4% to 70% for input power varying between -40 dBm to -5 dBm [135].

One interesting approach to increase the harvesting efficiency and reduce the interference is to use large antenna arrays. The RF signal can be directed using large antenna arrays and mmWave to mitigate the path-loss. This is however challenging when the direct line of sight path is not available, therefore advance signal processing techniques and beamforming [136] are required [135]. It also may put extra burden on the receiving node to communicate more with the base station to find the direct path.

Existing work on multi-antenna RF-enabled systems have mostly considered full channel state information (CSI) and to acquire that a certain amount of time should be allocated. Moreover, the user needs to use a portion of its harvested energy for sending training sequences assuming that the channel is reciprocal. However, the channel is usually not reciprocal. Existing techniques which rely on full CSI cannot be directly used for EF-enabled systems due to limited available energy in IoT devices. Further study in these areas is essential to fully understand the pros and cons of this approach and unleash the potential of mmWave and massive multiple-input multiple-output (MIMO) in the context of RF-enabled IoT systems. More effective CSI acquisition strategies should be considered

along with resource allocation to improve the efficiency of RF-enabled systems [135].

G. Half-duplex vs. Full-duplex

Wireless devices usually operates in a half-duplex mode, that is they do not transmit and receive at the same time. The main reason is to minimize the self-interference caused by the TX and RX circuits. However by using more sophisticated signal processing approaches effective self-interference cancellation can be developed and accordingly a full-duplex energy harvesting scenarios can be considered. This however comes with additional complexities which might not be suitable for many IoT devices. The main advantage of full-duplex systems is that the user can simultaneously harvest energy and transmit or receive information. Recent studies showed that full-duplex modes significantly improve the system throughput [132].

Imperfect self-interference cancellation however may lead to degradation of the throughput. Therefore, combination of full-duplex and half-duplex may be necessary to maintain a balance between throughput and energy efficiency. The associated complexity however may not be favourable for IoT use cases. More research in this area is necessary to develop low complexity schemes to enable device-level full-duplex mode. Moreover, dynamic resource allocation and power control should be fully investigated for dual mode scenarios.

H. Device-to-Device (D2D) Communications and Energy Economics

In D2D, devices are allowed to directly communicate with each other. This significantly helps to reduce the transmit power as the device transmits only to nearby devices. In D2D, direct communication with the base station may not be available, therefore relying only on harvesting energy from the signal transmitted by the base station is not feasible.

The same way that D2D communication enables data transfer between nearby devices, energy transfer between the devices should be enabled to create an adaptive and flexible wireless energy charging. This however may not be an option for low power wireless devices usually used in massive IoT scenarios. In particular in RF energy harvesting, the harvested energy depends on the received signal strength and the nearby devices may not be able to provide the required level of energy. IoT devices can request to harvest energy from more powerful devices nearby, however this requires an agreement between different sectors. In other words, the devices that request for energy from nearby devices need to pay for the service that they receive. it is still a major challenge in communication system especially in massive IoT systems to implement a low-cost and low-complexity transaction mechanisms to enable device to device interaction without the direct involvement of a third party such as the base station. Future research and development in this area are of utmost importance to fully unleash the potential of D2D-based EH enabled IoT systems.

Energy-efficient power control should be developed for D2D communications to enable cognitive radio-based IoT in cellular systems. In [137], a power control mechanism was designed where uplink resource blocks allocated to one cellular user

equipment are reused by multiple D2D pairs. Reducing the co-channel interference caused by resource sharing is however a significant challenge. Moreover, more thorough analysis and design should be developed when using EH techniques by taking into account the dynamic of energy harvesting and duty cycling.

VII. SECURITY CHALLENGES OF EH-ENABLED IOT SYSTEMS AND FUTURE RESEARCH DIRECTIONS

There are three main limiting factors which might lead to several potential security risks. These are mainly caused by the environment and impact the EH-enabled IoT devices. These include

1) *Unpredictable energy performance*: Energy harvesting from the environment is unpredictable; that is the amount of power which is produced in a particular time instance is random, which makes it difficult to continuously deliver sufficient power to the device. Harvesting sources also have low energy potential and low conversion efficiency [128]. Although the power management module and the effective use of battery or super-capacitors can partly solve this problem, this may lead to temporary security risks due service unavailability.

2) *Hazards and incidents*: The physical environment is very important in terms of reliability, possible hazards and incidents. In fact the device and EH circuit must be robust to real-world disruptions [128].

3) *Physical damage*: The physical property which is used to harvest energy from, can damage the associated electronics. For example, in a standard piezoelectric transducer which converts vibration to electricity, the printed-circuit boards of the electronics is subject to same vibration and can lead to premature failure. To avoid this, an accurate understanding of the generating environment, the power generated, and the time required, and the device power consumption and consumption time is required.

These limiting factors are potential sources of threats to the EH-enabled IoT systems. EH-enabled devices are vulnerable to malicious attacks that mainly limit accessing the energy resources. For example, IoT devices that are powered by PV cells may not receive enough sunlight, due to the blockage by a third-party, to perform their operations. Also, the target device might not be easily compromised, but the attackers could easily change other devices behavior or the surrounding environment, which have interdependence relationship to achieve their aims [138].

several papers in literature have studied the vulnerabilities, attacks and information leaks, and the design of security mechanism to provide security and privacy within the context of users and the devices. For a nice summary of these studies refer to [139]–[144]. These studies are however in their initial stages and lack applicability, and many problems remain open [138]. In particular, there is no unified framework to design a secure wireless systems based on EH techniques. When the devices are powered by EH sources, they are faced with an additional threat from the attacker who can change the environment. For example the RF source could be blocked and the devices cannot send their data anymore. In fact, the

more the devices are geared with the environment, the more they are vulnerable to the threats.

We conclude here that researchers need to investigate further to discover the new security threats and the root causes and new IoT features enabled by energy harvesting behind them. We need to design more generic and practical protective measures by taking into account the extra vulnerability added by energy harvesting mechanism. Relying only on energy harvesting techniques is a serious risk which should be carefully evaluated before investing in it. If there is no backup system, EH-enabled systems are not suitable for any application that deals with critical information and require high reliability, availability, and low end-to-end latency.

VIII. GREEN BIG DATA CHALLENGES

With the vast deployment of IoT applications and services, the amount of data which will be generated every second will be significantly increased. Big data is simply referred to huge or complex data that traditional data processing and analysis techniques are insufficient [145]. Big data is mainly categorized by 5 Vs, i.e., volume, variety, velocity, veracity, and value [146]. There are two main questions in big data; how to analyse the huge amount of data and how to resolve the issues related to sustainability and environment concerns [145].

There are mainly three layers in the big data market. The first layer is infrastructure layer, which mainly includes hardware components such as the external storage systems, servers, data centre networking infrastructure. The second layer is data organization, analytic, and management, which are mainly implemented in software. The service layer is actually the interface to external entities and applications.

The big data life cycle include data acquisition, data storage and data analytic. For data acquisition, the main trend now is to process the data as close as possible to the edge nodes. Technologies such as Fog computing [147], [148], are interesting technique to reduce the traffic load on the network. This will significantly reduce the data traffic and load on the data storage and servers too. There is also temporal correlation between the data generated over the same area, which can be taken into account when storing the data. Some innovative networking technologies, such as network function virtualization (NFV) [149] and software defined radio (SDN) [150], have been recently proposed in the big data era. These technologies provide flexible and customisable network architecture which can significantly reduce the energy consumption via dynamic resource management. There are still several challenging issues here that need to be solved in physical layer, medium access layer, and network layer [145].

The main energy consumers in big data are data centres and servers [145]. The increase energy consumption of these components will lead to a dramatic increase of green house emission which negatively impacts on environment. The problem becomes much bigger when we consider the data collection and acquisition by sensors and IoT devices. More storage capacity is needed to store various kind of big data. While distributed storage and recent advancements in this area may solve the storage problem, however these come with energy

and resource inefficiencies [151]. Moreover, big data analytics is required to analyze large-scale datasets. Although parallel computing and distributed schemes have been developed for this purpose, computational intensive big data analytics is one major consumer of energy [145]. Innovative infrastructures are required for efficient data analytic. Cloud computing [151] would be the way forward in order to leverage the potentials of distributed nodes in performing collaborative computing. While this has its own challenges, but it can be performed via low energy end devices operated by energy harvesting techniques.

IX. CONCLUSIONS

This paper reviews energy harvesting techniques for Internet of Things (IoT) services and applications. Over 50 billion multi-role devices, capable of sensing and actuating, will be installed by 2025, which shows a tremendous growth in the number of devices and creates new challenges and opportunities. A major burden is powering these devices, as using the main power and batteries is mostly restricted due to the small sizes of many devices and the fact that these devices are installed in hard-to-reach areas, where regular battery maintenance is impractical and very expensive. A viable solution is to use energy harvesting techniques to harvest energy from environment and provide enough energy to the devices to perform their operations. This will significantly increase the device life time and eliminate the need for the battery as an energy source. Different energy harvesting techniques were presented in this survey and pros and cons of each technique were discussed. As efficient energy harvesting technique, we focused on piezoelectric energy harvesting and radio frequency energy harvesting due. We briefly introduced the main concepts and design challenges for these technologies. As short-range wireless technologies are operating at mW power range, the development of battery-less IoT devices may be feasible. However, due to the large transmit power of most LPWAN technologies, which are expected to play key roles to provide massive IoT services, batteries will remain an essential parts of IoT devices operating over LPWANs. Energy harvesting techniques will then play key roles in increasing the device life-time by providing a sustainable way to recharge the batteries.

REFERENCES

- [1] Intel. (2017) The internet of things starts with intel inside. [Online]. Available: <https://www.intel.com/content/www/us/en/internet-of-things/overview.html?cv=1&session-id=a72c71a6dead059d17510ab183b548c4>
- [2] Gartner, Inc. (2014) Gartner says the internet of things will transform the data center. [Online]. Available: <http://www.gartner.com/newsroom/id/2684616>
- [3] Intel. Guide to iot, year = 2017, url = <http://www.intel.com/content/www/us/en/internet-of-things/infographics/guide-to-iot.html>, urldate = 2017-11-14.
- [4] K. Wang, Y. Wang, Y. Sun, S. Guo, and J. Wu, "Green industrial internet of things architecture: An energy-efficient perspective," *IEEE Communications Magazine*, vol. 54, no. 12, pp. 48–54, Dec. 2016.
- [5] H. Jayakumar, K. Lee, W. S. Lee, A. Raha, Y. Kim, and V. Raghunathan, "Powering the internet of things," in *Proceedings of the 2014 international symposium on Low power electronics and design*. ACM, 2014, pp. 375–380.

- [6] beecham research. (2017) M2M/IoT Sector Map. [Online]. Available: <http://www.beechamresearch.com/article.aspx?id=4>
- [7] F. Akhtar and M. H. Rehmani, "Energy replenishment using renewable and traditional energy resources for sustainable wireless sensor networks: A review," *Renewable and Sustainable Energy Reviews*, vol. 45, pp. 769–784, 2015. [Online]. Available: <http://www.sciencedirect.com/science/article/pii/S1364032115001094>
- [8] —, "Energy harvesting for self-sustainable wireless body area networks," *IT Professional*, vol. 19, no. 2, pp. 32–40, March 2017.
- [9] S. Chalasanani and J. M. Conrad, "A survey of energy harvesting sources for embedded systems," in *IEEE SoutheastCon 2008*. IEEE, 2008, pp. 442–447.
- [10] F. Yildiz, "Potential ambient energy-harvesting sources and techniques," 2009.
- [11] V. Raghunathan and P. H. Chou, "Design and power management of energy harvesting embedded systems," in *Proceedings of the 2006 international symposium on Low power electronics and design*. ACM, 2006, pp. 369–374.
- [12] D. Pimentel and P. Musilek, "Power management with energy harvesting devices," in *Electrical and Computer Engineering (CCECE), 2010 23rd Canadian Conference on*. IEEE, 2010, pp. 1–4.
- [13] W. K. Seah, Z. A. Eu, and H.-P. Tan, "Wireless sensor networks powered by ambient energy harvesting (wsn-heap)-survey and challenges," in *Wireless Communication, Vehicular Technology, Information Theory and Aerospace & Electronic Systems Technology, 2009. Wireless VITAE 2009. 1st International Conference on*. Ieee, 2009, pp. 1–5.
- [14] S. Sudevalayam and P. Kulkarni, "Energy harvesting sensor nodes: Survey and implications," *IEEE Communications Surveys & Tutorials*, vol. 13, no. 3, pp. 443–461, 2011.
- [15] MachinaResearch. (2016) Press release: Global internet of things market to grow to 27 billion devices, generating usd3 trillion revenue in 2025. [Online]. Available: <https://machinaresearch.com/news/press-release-global-internet-of-things-market-to-grow-to-27-billion-devices-generating-usd3-trillion-revenue-in-2025/>
- [16] GSMA, "3gpp low power wide area technologies white paper," Tech. Rep., 2016.
- [17] M. Shirvanimoghaddam, M. Dohler, and S. J. Johnson, "Massive non-orthogonal multiple access for cellular iot: Potentials and limitations," *IEEE Communications Magazine*, vol. 55, no. 9, pp. 55–61, 2017.
- [18] E. Le Sueur and G. Heiser, "Dynamic voltage and frequency scaling: The laws of diminishing returns," 2010.
- [19] M. D. Yin, J. Cho, and D. Park, "Pulse-based fast battery iot charger using dynamic frequency and duty control techniques based on multi-sensing of polarization curve," *Energies*, vol. 9, no. 3, p. 209, 2016.
- [20] S. F. Abedin, M. G. R. Alam, R. Haw, and C. S. Hong, "A system model for energy efficient green-iot network," in *International Conference on Information Networking (ICOIN)*. IEEE, 2015, pp. 177–182.
- [21] D. Akella Kamakshi, A. Shrivastava, and B. H. Calhoun, "A 0.2 v, 23 nw cmos temperature sensor for ultra-low-power iot applications," *Journal of Low Power Electronics and Applications*, vol. 6, no. 2, p. 10, 2016.
- [22] D. Park, J. M. Youn, and J. Cho, "A low-power microcontroller with accuracy-controlled event-driven signal processing unit for rare-event activity-sensing iot devices," *Journal of Sensors*, vol. 2015, 2015.
- [23] Texas Instruments. (2015) Ti makes battery-less iot connectivity possible with the industry's first multi-standard wireless microcontroller platform. [Online]. Available: <http://newscenter.ti.com/2015-02-25-TI-makes-battery-less-IoT-connectivity-possible-with-the-industrys-first-multi-standard-wireless-microcontroller-platform>
- [24] D. Bol, J. De Vos, F. Botman, G. de Streel, S. Bernard, D. Flandre, and J.-D. Legat, "Green socs for a sustainable internet-of-things," in *Faible Tension Faible Consommation (FTFC), 2013 IEEE*. IEEE, 2013, pp. 1–4.
- [25] I. J. Chang, S. P. Park, and K. Roy, "Exploring asynchronous design techniques for process-tolerant and energy-efficient subthreshold operation," *IEEE Journal of Solid-State Circuits*, vol. 45, no. 2, pp. 401–410, 2010.
- [26] S. Luetskemeier, T. Jungeblut, M. Pormann, and U. Rueckert, "A 200mv 32b subthreshold processor with adaptive supply voltage control," in *Solid-State Circuits Conference Digest of Technical Papers (ISSCC), 2012 IEEE International*. IEEE, 2012, pp. 484–486.
- [27] Z. Wang, Y. Liu, Y. Sun, Y. Li, D. Zhang, and H. Yang, "An energy-efficient heterogeneous dual-core processor for internet of things," in *Circuits and Systems (ISCAS), 2015 IEEE International Symposium on*. IEEE, 2015, pp. 2301–2304.
- [28] J. Henkel, S. Pagani, H. Amrouch, L. Bauer, and F. Samie, "Ultra-low power and dependability for iot devices (invited paper for iot technologies)," in *2017 Design, Automation & Test in Europe Conference & Exhibition (DATE)*. IEEE, 2017, pp. 954–959.
- [29] S. A. Alvi, G. A. Shah, and W. Mahmood, "Energy efficient green routing protocol for internet of multimedia things," in *Intelligent Sensors, Sensor Networks and Information Processing (ISSNIP), 2015 IEEE Tenth International Conference on*. IEEE, 2015, pp. 1–6.
- [30] H. Mamaghanian, N. Khaled, D. Atienza, and P. Vanderghyest, "Compressed sensing for real-time energy-efficient ecg compression on wireless body sensor nodes," *IEEE Transactions on Biomedical Engineering*, vol. 58, no. 9, pp. 2456–2466, 2011.
- [31] Z. T. Al-Azez, A. Q. Lawey, T. E. El-Gorashi, and J. M. Elmoghani, "Energy efficient iot virtualization framework with passive optical access networks," in *Transparent Optical Networks (ICTON), 2016 18th International Conference on*. IEEE, 2016, pp. 1–4.
- [32] J. Huang, Y. Meng, X. Gong, Y. Liu, and Q. Duan, "A novel deployment scheme for green internet of things," *IEEE Internet of Things Journal*, vol. 1, no. 2, pp. 196–205, 2014.
- [33] H. Chao, Y. Chen, and J. Wu, "Power saving for machine to machine communications in cellular networks," in *2011 IEEE GLOBECOM Workshops (GC Wkshps)*, Dec. 2011, pp. 389–393.
- [34] Silabs. (2015) Silicon labs and arm collaborate to drive the future of low-power arm mbed iot device platforms. [Online]. Available: <http://investor.silabs.com/releasedetail.cfm?releaseid=901283>
- [35] A. Saeed, A. Ahmadinia, A. Javed, and H. Larjani, "Intelligent intrusion detection in low-power iots," *ACM Transactions on Internet Technology (TOIT)*, vol. 16, no. 4, p. 27, 2016.
- [36] R. V. Prasad, S. Devasenapathy, V. S. Rao, and J. Vazifehdan, "Reincarnation in the ambiance: Devices and networks with energy harvesting," *IEEE Communications Surveys & Tutorials*, vol. 16, no. 1, pp. 195–213, 2014.
- [37] A. Somov and R. Giuffreda. (2015) Powering iot devices: Technologies and opportunities. [Online]. Available: <http://iot.ieee.org/newsletter/november-2015/powering-iot-devices-technologies-and-opportunities.html>
- [38] B. Franciscatto, "Design and implementation of a new low-power consumption DSRC transponder," Ph.D. dissertation, Universite Grenoble Alpes, 2014.
- [39] T. Tanaka, T. Suzuki, and K. Kurihara, "Energy harvesting technology for maintenance-free sensors," *Fujitsu Sci. Technol. J*, vol. 50, pp. 93–100, 2014.
- [40] T. Becker, M. Kluge, J. Schalk, K. Tiplady, C. Paget, U. Hilleringmann, and T. Otterpohl, "Autonomous sensor nodes for aircraft structural health monitoring," *IEEE Sensors Journal*, vol. 9, no. 11, pp. 1589–1595, 2009.
- [41] T. Torfs, T. Sterken, S. Brebels, J. Santana, R. van den Hoven, V. Spiering, N. Bertsch, D. Trapani, and D. Zonta, "Low power wireless sensor network for building monitoring," *IEEE Sensors Journal*, vol. 13, no. 3, pp. 909–915, 2013.
- [42] M. J. Whelan, M. V. Gangone, and K. D. Janoyan, "Highway bridge assessment using an adaptive real-time wireless sensor network," *IEEE Sensors Journal*, vol. 9, no. 11, pp. 1405–1413, 2009.
- [43] G. Park, T. Rosing, M. D. Todd, C. R. Farrar, and W. Hodgkiss, "Energy harvesting for structural health monitoring sensor networks," *Journal of Infrastructure Systems*, vol. 14, no. 1, pp. 64–79, 2008.
- [44] H. Bai, M. Atiquzzaman, and D. Lilja, "Wireless sensor network for aircraft health monitoring," in *Broadband Networks, 2004. BroadNets 2004. Proceedings. First International Conference on*. IEEE, 2004, pp. 748–750.
- [45] C. A. Nelson, S. R. Platt, D. Albrecht, V. Kamarajugadda, and M. Fateh, "Power harvesting for railroad track health monitoring using piezoelectric and inductive devices," in *The 15th International Symposium on Smart Structures and Materials & Nondestructive Evaluation and Health Monitoring*. International Society for Optics and Photonics, 2008, pp. 69 280R–69 280R.
- [46] H. Alemdar and C. Ersoy, "Wireless sensor networks for healthcare: A survey," *Computer Networks*, vol. 54, no. 15, pp. 2688–2710, 2010.
- [47] D. Mascareñas, E. Flynn, C. Farrar, G. Park, and M. Todd, "A mobile host approach for wireless powering and interrogation of structural health monitoring sensor networks," *IEEE Sensors Journal*, vol. 9, no. 12, pp. 1719–1726, 2009.
- [48] C. He, A. Arora, M. E. Kiziroglou, D. C. Yates, D. O'Hare, and E. M. Yeatman, "Mems energy harvesting powered wireless biometric sensor," in *2009 Sixth International Workshop on Wearable and Implantable Body Sensor Networks*. IEEE, 2009, pp. 207–212.

- [49] W. Y. Toh, Y. K. Tan, W. S. Koh, and L. Siek, "Autonomous wearable sensor nodes with flexible energy harvesting," *IEEE Sensors Journal*, vol. 14, no. 7, pp. 2299–2306, 2014.
- [50] P. De Mil, B. Jooris, L. Tytgat, R. Cateeuw, I. Moerman, P. Demeester, and A. Kamerman, "Design and implementation of a generic energy-harvesting framework applied to the evaluation of a large-scale electronic shelf-labeling wireless sensor network," *EURASIP journal on wireless communications and networking*, vol. 2010, no. 1, p. 1, 2010.
- [51] T. V. Prabhakar, A. U. Nambi Sn, H. Jamadagni, K. Swaroop, R. V. Prasad, and I. Niemegeers, "A novel dtn based energy neutral transfer scheme for energy harvested wsn gateways," *ACM SIGMETRICS Performance Evaluation Review*, vol. 38, no. 3, pp. 71–75, 2011.
- [52] M. D. Prieto, D. Z. Millan, W. Wang, A. M. Ortiz, J. A. O. Redondo, and L. R. Martinez, "Self-powered wireless sensor applied to gear diagnosis based on acoustic emission," *IEEE Transactions on Instrumentation and Measurement*, vol. 65, no. 1, pp. 15–24, 2016.
- [53] B. Aygün and V. Cagri Gungor, "Wireless sensor networks for structure health monitoring: recent advances and future research directions," *Sensor Review*, vol. 31, no. 3, pp. 261–276, 2011.
- [54] L. Hou and N. W. Bergmann, "Novel industrial wireless sensor networks for machine condition monitoring and fault diagnosis," *IEEE Transactions on Instrumentation and Measurement*, vol. 61, no. 10, pp. 2787–2798, 2012.
- [55] J. Hu, J. Jong, and C. Zhao, "Vibration energy harvesting based on integrated piezoelectric components operating in different modes," *IEEE transactions on ultrasonics, ferroelectrics, and frequency control*, vol. 57, no. 2, pp. 386–394, 2010.
- [56] A. Decker, "Solar energy harvesting for autonomous field devices," *IET Wireless Sensor Systems*, vol. 4, no. 1, pp. 1–8, 2014.
- [57] A. S. Weddell, M. Magno, G. V. Merrett, D. Brunelli, B. M. Al-Hashimi, and L. Benini, "A survey of multi-source energy harvesting systems," in *Proceedings of the Conference on Design, Automation and Test in Europe*. EDA Consortium, 2013, pp. 905–908.
- [58] Silicon Labs. (2015) Battery size matters. [Online]. Available: <https://www.silabs.com/Support%20Documents/TechnicalDocs/battery-life-in-connected-wireless-iot-devices.pdf>
- [59] IDTechEx. (2011) Energyharvesting and storage for electronic devices 2011–2021. [Online]. Available: <http://www.idtechex.com/research/reports/energy-harvesting-and-storage-for-electronic-devices-2011-2021-000270.asp>
- [60] BusinessWire. (2016) Global energy harvesting market worth usd 3.3 billion by 2020 - analysis, technologies & forecasts report 2016-2020 - research and markets. [Online]. Available: <http://www.businesswire.com/news/home/20160607006433/en/Global-Energy-Harvesting-Market-Worth-USD-3.3>
- [61] FutureMarketInsight. (2017) Energy harvesting market: Global industry analysis and opportunity assessment 2014 - 2020. [Online]. Available: <https://www.futuremarketinsights.com/reports/global-energy-harvesting-market>
- [62] TrancparancyMarketResearch. (2017) Piezoelectric energy harvesting market - global industry analysis, size, share, trends, analysis, growth and forecast, 2016 - 2023. [Online]. Available: <https://www.transparencymarketresearch.com/piezoelectric-energy-harvesting-market.html>
- [63] F. R. Fan, W. Tang, and Z. L. Wang, "Flexible nanogenerators for energy harvesting and self-powered electronics," *Advanced Materials*, 2016.
- [64] R. Das. (2012) Piezoelectric energy harvesting market to reach \$145 million in 2018. [Online]. Available: <https://www.energyharvestingjournal.com/articles/4664/piezoelectric-energy-harvesting-market-to-reach-145-million-in-2018>
- [65] "Cellular networks for massive IoT," Ericsson, Tech. Rep. Uen 284 23-3278, January 2016. [Online]. Available: https://www.ericsson.com/res/docs/whitepapers/wp_iiot.pdf
- [66] Element14 Community. (2015) Why the internet of things needs energy harvesting. [Online]. Available: <https://www.element14.com/community/groups/internet-of-things/blog/2015/07/28/how-energy-harvesting-can-keep-the-iiot-powered-up-and-growing>
- [67] Imprint Energy. (2016) Transforming the battery landscape. [Online]. Available: <http://www.imprintenergy.com/>
- [68] Cymbet. (2015) Enerchip smart solid state batteries. [Online]. Available: <http://www.cymbet.com/products/enerchip-solid-state-batteries.php>
- [69] H. R. Byon and Y. Zhao, "Aqueous lithium-iodine battery," in *Meeting Abstracts*, no. 2. The Electrochemical Society, 2014, pp. 104–104.
- [70] W. Greatbatch, C. Holmes, E. Takeuchi, and S. Ebel, "Lithium/carbon monofluoride (li/cfx): a new pacemaker battery," *Pacing and clinical electrophysiology*, vol. 19, no. 11, pp. 1836–1840, 1996.
- [71] I. Cowie. (2014) All about batteries, part 10: Lithium sulfur dioxide (liso2) — ee times. [Online]. Available: http://www.eetimes.com/author.asp?section_id=36&doc_id=1323439.
- [72] ——. (2014) All about batteries, part 7: Lithium thionyl chloride — ee times. [Online]. Available: http://www.eetimes.com/author.asp?section_id=36&doc_id=1322276
- [73] C. Menachem and H. Yamin, "High-energy, high-power pulses plus battery for long-term applications," *Journal of power sources*, vol. 136, no. 2, pp. 268–275, 2004.
- [74] W. Rowe. (2016) Iot battery outlook: Types of batteries for iot devices. [Online]. Available: <http://internetofthingsagenda.techtarget.com/feature/IoT-battery-outlook-Types-of-batteries-for-IoT-devices>
- [75] M. Safak, "Wireless sensor and communication nodes with energy harvesting," *Journal of Communication, Navigation, Sensing and Services (CONASENSE)*, vol. 1, no. 1, pp. 47–66, 2014.
- [76] P. Kamalinejad, C. Mahapatra, Z. Sheng, S. Mirabbasi, V. C. Leung, and Y. L. Guan, "Wireless energy harvesting for the internet of things," *IEEE Communications Magazine*, vol. 53, no. 6, pp. 102–108, 2015.
- [77] DRAYSON TECHNOLOGIES LTD. (2016) Rf energy harvesting for the low energy internet of things. [Online]. Available: <http://www.getfreevolt.com/>
- [78] R. J. Vyas, B. B. Cook, Y. Kawahara, and M. M. Tentzeris, "E-welp: A batteryless embedded sensor-platform wirelessly powered from ambient digital-tv signals," *IEEE Transactions on Microwave Theory and Techniques*, vol. 61, no. 6, pp. 2491–2505, June 2013.
- [79] B. Kellogg, A. Parks, S. Gollakota, J. R. Smith, and D. Wetherall, "Wi-fi backscatter: Internet connectivity for rf-powered devices," in *ACM SIGCOMM Computer Communication Review*, vol. 44, no. 4. ACM, 2014, pp. 607–618.
- [80] A. M. Hawkes, A. R. Katko, and S. A. Cummer, "A microwave metamaterial with integrated power harvesting functionality," *Applied Physics Letters*, vol. 103, no. 16, p. 163901, 2013.
- [81] S. Qi, M. Oudich, Y. Li, and B. Assouar, "Acoustic energy harvesting based on a planar acoustic metamaterial," *Applied Physics Letters*, vol. 108, no. 26, p. 263501, 2016.
- [82] J. Tervo, A. Manninen, R. Ilola, and H. Hänninen, "State-of-the-art of thermoelectric materials processing," *Ju lkaisija-Utgivare Publisher, Finland*, pp. 6–7, 2009.
- [83] Y. Zhao, J. S. Dyck, B. M. Hernandez, and C. Burda, "Enhancing thermoelectric performance of ternary nanocrystals through adjusting carrier concentration," *Journal of the American Chemical Society*, vol. 132, no. 14, pp. 4982–4983, 2010.
- [84] A. Z. Kausar, A. W. Reza, M. U. Saleh, and H. Ramiah, "Energizing wireless sensor networks by energy harvesting systems: Scopes, challenges and approaches," *Renewable and Sustainable Energy Reviews*, vol. 38, pp. 973–989, 2014.
- [85] X. Lu and S.-H. Yang, "Thermal energy harvesting for wsns," in *IEEE International Conference on Systems Man and Cybernetics (SMC)*. IEEE, 2010, pp. 3045–3052.
- [86] Z.-G. Chen, G. Han, L. Yang, L. Cheng, and J. Zou, "Nanostructured thermoelectric materials: Current research and future challenge," *Progress in Natural Science: Materials International*, vol. 22, no. 6, pp. 535–549, 2012.
- [87] N. Satyala, P. Norouzzadeh, and D. Vashaee, "Nano bulk thermoelectrics: Concepts, techniques, and modeling," in *Nanoscale Thermoelectrics*. Springer, 2014, pp. 141–183.
- [88] (2014) Thermo life energy corp. [Online]. Available: <http://www.poweredbythermolife.com/>
- [89] F. K. Shaikh and S. Zeadally, "Energy harvesting in wireless sensor networks: A comprehensive review," *Renewable and Sustainable Energy Reviews*, vol. 55, pp. 1041 – 1054, 2016.
- [90] V. Leonov, T. Torfs, P. Fiorini, and C. Van Hoof, "Thermoelectric converters of human warmth for self-powered wireless sensor nodes," *IEEE Sensors Journal*, vol. 7, no. 5, pp. 650–657, 2007.
- [91] Z. Wang, V. Leonov, P. Fiorini, and C. Van Hoof, "Realization of a wearable miniaturized thermoelectric generator for human body applications," *Sensors and Actuators A: Physical*, vol. 156, no. 1, pp. 95–102, 2009.
- [92] A. Cuadras, M. Gasulla, and V. Ferrari, "Thermal energy harvesting through pyroelectricity," *Sensors and Actuators A: Physical*, vol. 158, no. 1, pp. 132–139, 2010.
- [93] M. Ferrari, V. Ferrari, D. Marioli, and A. Taroni, "Modeling, fabrication and performance measurements of a piezoelectric energy converter for

- power harvesting in autonomous microsystems,” *IEEE transactions on instrumentation and measurement*, vol. 55, no. 6, pp. 2096–2101, 2006.
- [94] A. Harb, “Energy harvesting: State-of-the-art,” *Renewable Energy*, vol. 36, no. 10, pp. 2641–2654, 2011.
- [95] Y. Wang, Y. Liu, C. Wang, Z. Li, X. Sheng, H. G. Lee, N. Chang, and H. Yang, “Storage-less and converter-less photovoltaic energy harvesting with maximum power point tracking for internet of things,” *IEEE Transactions on Computer-Aided Design of Integrated Circuits and Systems*, vol. 35, no. 2, pp. 173–186, 2016.
- [96] M. Raju and M. Grazier. (2012) Ulp meets energy harvesting. [Online]. Available: http://www.extensionmedia.com/basecamp/54722/eecatlowpovermarch2011/ULP_MEETS_ENERGY_TI_v1.pdf
- [97] C. Ó. Mathúna, T. ODonnell, R. V. Martinez-Catala, J. Rohan, and B. OFlynn, “Energy scavenging for long-term deployable wireless sensor networks,” *Talanta*, vol. 75, no. 3, pp. 613–623, 2008.
- [98] J. Li, A. Liu, G. Shen, L. Li, C. Sun, and F. Zhao, “Retro-vlc: Enabling battery-free duplex visible light communication for mobile and iot applications,” in *Proceedings of the 16th International Workshop on Mobile Computing Systems and Applications*. ACM, 2015, pp. 21–26.
- [99] E. Sazonov, H. Li, D. Curry, and P. Pillay, “Self-powered sensors for monitoring of highway bridges,” *IEEE Sensors Journal*, vol. 9, no. 11, pp. 1422–1429, 2009.
- [100] T. Sterken, P. Fiorini, K. Baert, R. Puers, and G. Borghs, “An electret-based electrostatic/spl mu/-generator,” in *TRANSDUCERS, Solid-State Sensors, Actuators and Microsystems, 12th International Conference on, 2003*, vol. 2. IEEE, 2003, pp. 1291–1294.
- [101] E. Dallago, A. Danioni, M. Marchesi, V. Nucita, and G. Venchi, “A self-powered electronic interface for electromagnetic energy harvester,” *IEEE Transactions on Power Electronics*, vol. 26, no. 11, pp. 3174–3182, 2011.
- [102] T. Starner, “Human-powered wearable computing,” *IBM systems Journal*, vol. 35, no. 3.4, pp. 618–629, 1996.
- [103] K. MacVittie, J. Halánek, L. Halámková, M. Southcott, W. D. Jemison, R. Lobel, and E. Katz, “From cyborg lobsters to a pacemaker powered by implantable biofuel cells,” *Energy & Environmental Science*, vol. 6, no. 1, pp. 81–86, 2013.
- [104] N. S. Shenck and J. A. Paradiso, “Energy scavenging with shoe-mounted piezoelectrics,” *IEEE micro*, vol. 21, no. 3, pp. 30–42, 2001.
- [105] S. R. Platt, S. Farritor, K. Garvin, and H. Haider, “The use of piezoelectric ceramics for electric power generation within orthopedic implants,” *IEEE/ASME Transactions on Mechatronics*, vol. 10, no. 4, pp. 455–461, 2005.
- [106] C. Dagdeviren, B. D. Yang, Y. Su, P. L. Tran, P. Joe, E. Anderson, J. Xia, V. Doraiswamy, B. Dehdashti, X. Feng *et al.*, “Conformal piezoelectric energy harvesting and storage from motions of the heart, lung, and diaphragm,” *Proceedings of the National Academy of Sciences*, vol. 111, no. 5, pp. 1927–1932, 2014.
- [107] S. J. Roundy, “Energy scavenging for wireless sensor nodes with a focus on vibration to electricity conversion,” Ph.D. dissertation, University of California, Berkeley, 2003.
- [108] B. I. Rapoport, J. T. Kedzierski, and R. Sarpeshkar, “A glucose fuel cell for implantable brain–machine interfaces,” *PLoS one*, vol. 7, no. 6, p. e38436, 2012.
- [109] W. Jia, G. Valdés-Ramírez, A. J. Bandodkar, J. R. Windmiller, and J. Wang, “Epidermal biofuel cells: energy harvesting from human perspiration,” *Angewandte Chemie International Edition*, vol. 52, no. 28, pp. 7233–7236, 2013.
- [110] Z. L. Wang and W. Wu, “Nanotechnology-enabled energy harvesting for self-powered micro-/nanosystems,” *Angewandte Chemie International Edition*, vol. 51, no. 47, pp. 11 700–11 721, 2012.
- [111] L. Mateu and F. Moll, “Review of energy harvesting techniques and applications for microelectronics (keynote address),” in *VLSI Circuits and Systems II*, vol. 5837. International Society for Optics and Photonics, 2005, pp. 359–374.
- [112] A. Zurbuchen, A. Pfenninger, A. Stahel, C. T. Stoeck, S. Vandenberghe, V. M. Koch, and R. Vogel, “Energy harvesting from the beating heart by a mass imbalance oscillation generator,” *Annals of biomedical engineering*, vol. 41, no. 1, pp. 131–141, 2013.
- [113] M. J. Ramsay and W. W. Clark, “Piezoelectric energy harvesting for bio-mems applications,” in *Smart Structures and Materials 2001: Industrial and Commercial Applications of Smart Structures Technologies*, vol. 4332. International Society for Optics and Photonics, 2001, pp. 429–439.
- [114] N. G. Elvin and A. A. Elvin, “Vibrational energy harvesting from human gait,” *IEEE/ASME Transactions on Mechatronics*, vol. 18, no. 2, pp. 637–644, 2013.
- [115] P. D. Mitcheson, E. M. Yeatman, G. K. Rao, A. S. Holmes, and T. C. Green, “Energy harvesting from human and machine motion for wireless electronic devices,” *Proceedings of the IEEE*, vol. 96, no. 9, pp. 1457–1486, 2008.
- [116] D. Benasciutti and L. Moro, “Energy harvesting with vibrating shoe-mounted piezoelectric cantilevers,” in *Advances in Energy Harvesting Methods*. Springer, 2013, pp. 141–162.
- [117] G.-T. Hwang, H. Park, J.-H. Lee, S. Oh, K.-I. Park, M. Byun, H. Park, G. Ahn, C. K. Jeong, K. No *et al.*, “Self-powered cardiac pacemaker enabled by flexible single crystalline pmn-pt piezoelectric energy harvester,” *Advanced materials*, vol. 26, no. 28, pp. 4880–4887, 2014.
- [118] K.-I. Park, S. Xu, Y. Liu, G.-T. Hwang, S.-J. L. Kang, Z. L. Wang, and K. J. Lee, “Piezoelectric batio3 thin film nanogenerator on plastic substrates,” *Nano letters*, vol. 10, no. 12, pp. 4939–4943, 2010.
- [119] J. Kwon, W. Seung, B. K. Sharma, S.-W. Kim, and J.-H. Ahn, “A high performance pzt ribbon-based nanogenerator using graphene transparent electrodes,” *Energy & Environmental Science*, vol. 5, no. 10, pp. 8970–8975, 2012.
- [120] G. Heckmann, “Die gittertheorie der festen körper,” in *Ergebnisse der exakten naturwissenschaften*. Springer, 1925, pp. 100–153.
- [121] M. De Jong, W. Chen, H. Geerlings, M. Asta, and K. A. Persson, “A database to enable discovery and design of piezoelectric materials,” *Scientific data*, vol. 2, 2015.
- [122] O. Brand, G. K. Fedder, C. Hierold, J. G. Korvink, O. Tabata, D. Briand, E. Yeatman, and S. Roundy, *Micro energy harvesting*. John Wiley & Sons, 2015.
- [123] R. Caliò, U. B. Rongala, D. Camboni, M. Milazzo, C. Stefanini, G. de Petris, and C. M. Oddo, “Piezoelectric energy harvesting solutions,” *Sensors*, vol. 14, no. 3, pp. 4755–4790, 2014.
- [124] B. Lin and V. Giurgiutiu, “Modeling and testing of PZT and PVDF piezoelectric wafer active sensors,” *Smart Materials and Structures*, vol. 15, no. 4, p. 1085, 2006.
- [125] L. Capineri, L. Masotti, V. Ferrari, D. Marioli, A. Taroni, and M. Mazzoni, “Comparisons between PZT and PVDF thick films technologies in the design of low-cost pyroelectric sensors,” *Review of scientific instruments*, vol. 75, no. 11, pp. 4906–4910, 2004.
- [126] S. Crossley and S. Kar-Narayan, “Energy harvesting performance of piezoelectric ceramic and polymer nanowires,” *Nanotechnology*, vol. 26, no. 34, p. 344001, 2015.
- [127] B. Lin and V. Giurgiutiu, “Modeling and testing of PZT and PVDF piezoelectric wafer active sensors,” *Smart Materials and Structures*, vol. 15, no. 4, p. 1085, 2006.
- [128] Avnet. (2016) Powering the internet of things via energy harvesting. [Online]. Available: <http://design.avnet.com/axiom/powering-the-internet-of-things-via-energy-harvesting/>
- [129] Cypress Core&Code. (2015) Energy-harvesting devices replace batteries in iot sensors. [Online]. Available: <http://core.spansion.com/article/energy-harvesting-devices-replace-batteries-in-iot-sensors/#.WCkFC195aQ>
- [130] G. Yang, V. Y. Tan, C. K. Ho, S. H. Ting, and Y. L. Guan, “Wireless compressive sensing for energy harvesting sensor nodes,” *IEEE Transactions on Signal Processing*, vol. 61, no. 18, pp. 4491–4505, 2013.
- [131] H. Sharma and P. Balamuralidhar, “A transmission scheme for robust delivery of urgent/critical data in internet of things,” in *2013 Fifth International Conference on Communication Systems and Networks (COMSNETS)*. IEEE, 2013, pp. 1–7.
- [132] P. Ramezani and A. Jamalipour, “Toward the evolution of wireless powered communication networks for the future internet of things,” *IEEE Network*, vol. 31, no. 6, pp. 62–69, 2017.
- [133] M. A. Kishk and H. S. Dhillon, “Joint uplink and downlink coverage analysis of cellular-based rf-powered iot network,” *IEEE Transactions on Green Communications and Networking*, vol. 2, no. 2, pp. 446–459, 2018.
- [134] A. A. Khan, M. H. Rehmani, and A. Rachedi, “Cognitive-radio-based internet of things: Applications, architectures, spectrum related functionalities, and future research directions,” *IEEE wireless communications*, vol. 24, no. 3, pp. 17–25, 2017.
- [135] D. Niyato, D. I. Kim, M. Maso, and Z. Han, “Wireless powered communication networks: Research directions and technological approaches,” *IEEE Wireless Communications*, vol. 24, no. 6, pp. 88–97, 2017.
- [136] Y. Alsaba, S. K. A. Rahim, and C. Y. Leow, “Beamforming in wireless energy harvesting communications systems: A survey,” *IEEE*

Communications Surveys & Tutorials, vol. 20, no. 2, pp. 1329–1360, 2018.

- [137] K. Yang, S. Martin, C. Xing, J. Wu, and R. Fan, “Energy-efficient power control for device-to-device communications,” *IEEE Journal on Selected Areas in Communications*, vol. 34, no. 12, pp. 3208–3220, Dec. 2016.
- [138] W. Zhou, Y. Jia, A. Peng, Y. Zhang, and P. Liu, “The Effect of IoT New Features on Security and Privacy: New Threats, Existing Solutions, and Challenges Yet to Be Solved,” *IEEE Internet of Things Journal*, 2018.
- [139] S. Li, T. Tryfonas, and H. Li, “The internet of things: a security point of view,” *Internet Research*, vol. 26, no. 2, pp. 337–359, 2016.
- [140] J. Lin, W. Yu, N. Zhang, X. Yang, H. Zhang, and W. Zhao, “A survey on internet of things: Architecture, enabling technologies, security and privacy, and applications,” *IEEE Internet of Things Journal*, vol. 4, no. 5, pp. 1125–1142, 2017.
- [141] K. Fu, T. Kohno, D. Lopresti, E. Mynatt, K. Nahrstedt, S. Patel, D. Richardson, and B. Zorn, “Safety, security, and privacy threats posed by accelerating trends in the internet of things,” Technical Report. Computing Community Consortium. <http://cra.org/ccc/wp-content/uploads/sites/2/2017/02/Safety-Security-and-Privacy-Threats-in-IoT.pdf>, Tech. Rep., 2017.
- [142] R. Roman, J. Zhou, and J. Lopez, “On the features and challenges of security and privacy in distributed internet of things,” *Computer Networks*, vol. 57, no. 10, pp. 2266–2279, 2013.
- [143] S. Sicari, A. Rizzardi, L. A. Grieco, and A. Coen-Porisini, “Security, privacy and trust in internet of things: The road ahead,” *Computer networks*, vol. 76, pp. 146–164, 2015.
- [144] Y. Yang, L. Wu, G. Yin, L. Li, and H. Zhao, “A survey on security and privacy issues in internet-of-things,” *IEEE Internet of Things Journal*, vol. 4, no. 5, pp. 1250–1258, 2017.
- [145] J. Wu, S. Guo, J. Li, and D. Zeng, “Big data meet green challenges: Greening big data,” *IEEE Systems Journal*, vol. 10, no. 3, pp. 873–887, Sep. 2016.
- [146] D. Beulke *et al.*, “Big data impacts data management: The 5 vs of big data,” URL: <http://davebeulke.com/big-data-impacts-datamanagement-the-five-vs-of-big-data>, 2011.
- [147] A. Yousefpour, G. Ishigaki, R. Gour, and J. P. Jue, “On reducing iot service delay via fog offloading,” *IEEE Internet of Things Journal*, vol. 5, no. 2, pp. 998–1010, April 2018.
- [148] M. Chiang and T. Zhang, “Fog and iot: An overview of research opportunities,” *IEEE Internet of Things Journal*, vol. 3, no. 6, pp. 854–864, Dec 2016.
- [149] J. Li, J. Jin, D. Yuan, and H. Zhang, “Virtual fog: A virtualization enabled fog computing framework for internet of things,” *IEEE Internet of Things Journal*, vol. 5, no. 1, pp. 121–131, Feb 2018.
- [150] C. Li, Z. Qin, E. Novak, and Q. Li, “Securing sdn infrastructure of iot? fog networks from mitm attacks,” *IEEE Internet of Things Journal*, vol. 4, no. 5, pp. 1156–1164, Oct 2017.
- [151] R. Muoz, R. Vilalta, N. Yoshikane, R. Casellas, R. Martinez, T. Tsuritani, and I. Morita, “Integration of iot, transport sdn, and edge/cloud computing for dynamic distribution of iot analytics and efficient use of network resources,” *Journal of Lightwave Technology*, vol. 36, no. 7, pp. 1420–1428, April 2018.



Mahyar Shirvanimoghaddam (S’12-M’15) received the B.Sc. degree (Hons.) from the University of Tehran, Iran, in 2008, the M.Sc. degree (Hons.) from Sharif University of Technology, Iran, in 2010, and the Ph.D. degree from The University of Sydney, Australia, in 2015, all in electrical engineering. He held a post-doctoral research position with the School of Electrical Engineering and Computer Science, University of Newcastle, Australia. Since 2016, he has been with the School of Electrical and Information Engineering, The University of Sydney, as a Scholarly Teaching Fellow in telecommunications. His general research interests include channel coding techniques, cooperative communications, compressed sensing, machine-to-machine communications, and wireless sensor networks. He was selected as an Exemplary Reviewer of the IEEE Communication Letters and the IEEE Transaction on Communications.



Kamyar Shirvanimoghaddam is a PhD candidate in Institute for Frontier Materials, Deakin University, Australia. He worked as a materials scientist in different companies and universities since 2004 when he graduated from University of Tehran, Iran. As a doctoral candidate, he is focusing on develop a new periodical patterned CNT for high tech applications such as sensors and nanogenerators. His expertise includes Carbonaceous structure, composite materials, and piezoelectric polymers.



Mohammad Mahdi Abolhasani received his PhD degree in polymer engineering from Amirkabir University of Technology, Tehran, Iran. His PhD research work contributed to the demonstration of effects of nanofillers and dynamic vulcanization on crystalline polymorphism of PVDF. Then, he joined University of Kashan, Iran, as an assistant professor. His work at Kashan was focused on investigation of piezoelectric performance of PVDF films and fibers. In 2014, he did a Postdoc in Deakin University, Australia. In 2016, he received a fellowship from the Alexander von Humboldt Foundation for a project on high-K ferroelectric polymers for energy storage application. He is now a Postdoc researcher in Max-Planck institute for polymer research, Germany.



Majid Farhangi received the B.Sc. degree in Electrical Engineering from the IAUCTB, Tehran, Iran, in 2015. Currently, he is pursuing the Master of Electrical Engineering degree at the University of Sydney, Australia. His current research interests mainly focus on high-efficiency DC-DC converters, wireless power transmission and high frequency induction heating systems.



Vahid Zahiri Barsari received the B.S. degree in electrical engineering from IAUCTB, Tehran, Iran, in 2015. Currently, he is pursuing the Master of Electrical Engineering degree at the University of Sydney, Australia. His current research interests mainly focus on power electronics, power inverter and designing inductive power transfer systems for electric vehicles.



Hangyue Liu (S’16) received the B.E. degree from SouthWest Jiaotong University, Chengdu, China, in 2014 and the M.E. degree in electrical engineering from the University of Sydney, Sydney, Australia, in 2017. He is currently a research assistant with the School of Electrical and Information Engineering, University of Sydney, Sydney, Australia. His current research interests include demand response, energy management in residential buildings, and applications of IoT in smart grid.



Mischa Dohler (S'99-M'03-SM'07-F'14) is currently a Full Professor in Wireless Communications with Kings College London, the Head of the Centre for Telecommunications Research, and a co-founder and a member of the Board of Directors of the smart city pioneer Worldensing. He was a Distinguished Lecturer of the IEEE. He was the Editor-in-Chief of the Transactions on Emerging Telecommunications Technologies and the Transactions on the Internet of Things.

He is a frequent keynote, panel and tutorial speaker, and has received numerous awards. He has pioneered several research fields, contributed to numerous wireless broadband, IoT/M2M and cyber security standards, holds a dozen patents, organized and chaired numerous conferences, has more than 200 publications, and authored several books.

He acts as policy, technology and entrepreneurship adviser, examples being Richard Bransons Carbon War Room, House of Parliament UK, UK Ministry BIS, EPSRC ICT Strategy Advisory Team, European Commission, Tech London Advocate, ISO Smart City working group, and various start-ups. He is also an entrepreneur, angel investor, passionate pianist and fluent in 6 languages. He has talked at TEDx. He had coverage by national and international TV & radio; and his contributions have featured on BBC News and the Wall Street Journal.



Minoo Naebe received the the B.Sc. (Hons.) and M.S degrees from the Isfahan University of Technology (IUT), Isfahan, Iran, and the Ph.D. degree from Deakin University, Australia (2008). She is a Senior Research Fellow and the Theme Leader for High Performance Materials with Carbon Nexus, Institute for Frontier Materials, Deakin University. Her research interests include advanced polymer (nano) composites and fibres and applications in various industries aerospace, automotive, oil and gas.