

ACTIDS: An Active Strategy For Detecting And Localizing Network Attacks

Eitan Menahem, Gabi Nakibly, Yuval Elovici

Abstract—In this work we investigate a new approach for detecting attacks which aim to degrade the network's Quality of Service (QoS). To this end, a new network-based intrusion detection system (NIDS) is proposed. Most contemporary NIDSs take a passive approach by solely monitoring the network's production traffic. This paper explores a complementary approach in which distributed agents actively send out periodic probes. The probes are continuously monitored to detect anomalous behavior of the network. The proposed approach takes away much of the variability of the network's production traffic that makes it so difficult to classify. This enables the NIDS to detect more subtle attacks which would not be detected using the passive approach alone. Furthermore, the active probing approach allows the NIDS to be effectively trained using only examples of the network's normal states, hence enabling an effective detection of zero-day attacks. Using realistic experiments, we show that an NIDS which also leverages the active approach is considerably more effective in detecting attacks which aim to degrade the network's QoS when compared to an NIDS which relies solely on the passive approach. Lastly, we show that the false positives rate remains very low even in the face of Byzantine faults.

Index Terms—Anomaly-Based Network Intrusion Detection System, Active Probing, One-Class Learning, Ensemble Learning



1 INTRODUCTION

Network intrusion detection systems (NIDS) are key in the security architecture of many organizations. A typical NIDS inspects traffic flowing into, out of, or inside the target network while attempting to isolate a malicious activity. Broadly speaking, an NIDS tries to identify two types of malicious activities. The first type includes attacks carried over network traffic that target end nodes. One such example is a worm that aims to infect and take control over end nodes. Another example is a reconnaissance activity that scans active IP addresses or opens ports at some end nodes. The second type of attack targets the network itself. Attacks of this type include exhaustion of a link's bandwidth by overwhelming it with traffic as well as unauthorized modification of a network's routing process. The ultimate goal of such attacks is to degrade the QoS provided by the network to its users.

Traditionally, NIDSs are broadly classified based on the style of detection they use. Some systems rely on a precise description of the malicious activity, i.e., knowledge-based (signature-based) detection. Other systems rely on statistical modeling of the network's normal state and regard significant deviations from this state as attacks, i.e., anomaly-based detection.

The current paper addresses the problem of detecting QoS degrading attacks which target the network

itself, and further focuses on attack classes which have not yet been seen before, i.e., zero-day attacks. In order to detect new attack classes, an IDS should not rely on the description of known attacks (e.g., DNS poisoning or OSPF attacks), their specific features (e.g., increased number of failed TCP connections) or even on monitoring known attack surfaces (e.g., DNS cache or routing table), since a new attack class might exploit the vulnerabilities of previously unexplored attack surfaces, which might have significantly different features from those of previous attacks. Consequently, the knowledge-based IDS approach is not suitable for the task at hand. Hence, in the rest of the paper we focus on the anomaly-based detection approach.

Most anomaly-based NIDS take a passive approach. They rely exclusively on monitoring the network's production traffic and extracting the relevant features that indicate the progression of an attack. However, experience has shown that the immense variability of network traffic is a major stumbling block of the NIDS [1]. Such variability is demonstrated in many of the network's traffic features and consequently makes them very difficult to predict over short time scales (seconds to hours) and furthermore presents difficulties in detecting anomalies generated by the network attacks. In addition, a passive NIDS needs to process all the production traffic flowing through it. It has been shown that anomaly-based NIDS are unable to run at line rate in the network core [2]. In order to mitigate this problem, an NIDS may be deployed closer to the network edge where its visibility of the entire network traffic is reduced. Alternatively, packet flow sampling may be used, however, that can further

• E. Menahem, and Y. Elovici are with the Telekom Innovation Laboratories and information System Engineering Department, Ben-Gurion University, Be'er Sheva, 84105, Israel and G. Nakibly is with Rafael – Advanced Defense Systems Ltd., Haifa, Israel
Email: {eitanme,elovici}@post.bgu.ac.il, gabin@rafael.co.il

degrade the detection accuracy [3].

Our work takes a somewhat different approach and aims to complement the pitfalls of the passive approach. We propose to produce artificial probing traffic exchanged between various agents over the network. General QoS features are then extracted from the probing traffic, rather than from the production traffic. Lastly, anomalies are identified based on those features. The rationale of this approach is as follows. First, the probing traffic is much more predictable than the production traffic and therefore an abrupt change in one of the features gleaned from that traffic is most likely sourced at an anomaly of the network rather than a legitimate shift of traffic. This approach takes away much of the variability of network traffic which makes it so difficult to predict. Secondly, the probing traffic is treated by the network as regular production traffic and therefore probing traffic will be affected by network attacks as much as the production traffic is. Thus, the detection potential is not diminished.

Note that a fundamental property to this approach is that it detects anomalies produced by the attack *effects* on the network, such as changes in traffic delays or packet losses. This allows us to detect any attack, including zero-day attacks, as long as it affects the network's QoS parameters. In particular, we do not attempt to monitor the by-products effects of specific types of attacks, such as the increased number of failed TCP connections, increased traffic volume, shifts in port or IP distribution or changes to routing tables and DNS caches. This will allow us to identify a wide range of attacks which target the network, regardless of their nature or the techniques they employ. Examples of such attacks include but are not limited to: 1) subversion of the routing process in the network; 2) poisoning of basic network services, such as the DNS; and 3) overloading of the network's links or routers. Overall, our NIDS architecture aims to detect every attack that has some adverse effect on the service provided to users by the network.

Another key feature of our work is the use of one-class learning. Our NIDS is trained only on a normal network state. This means that network attack records and specifications are not required, further creating substantial operational benefits. The key assumption of this strategy is that it is possible to obtain a complete picture of almost all normal states in the network and thereby reliably infer that any other state is anomalous. This assumption is known as the Closed World assumption [4]. In general, the assumption is believed to be impractical for most real-life problems since it is impossible to cover all normal states. Nonetheless, our work focuses on the network's effects and the QoS it provides to its users. This QoS is generally regarded as stable and predictable to the extent that many network operators have commercial obligations to it under service level

agreements (SLAs). Therefore, our working assumption is that we can cover all normal network states with a high degree of confidence. Furthermore, it has been shown [5] that a deviation of network performance for operational purposes can be successfully detected using anomaly detection techniques.

1.1 Applicability

The NIDS architecture proposed in this work aims to identify and locate attacks that have an adverse effect on the network and service provided to its users. That is, our aim is not to find attacks on the network's end hosts that do not affect the network itself, such as the silent spread of a worm in the network, a slow port scan or a buffer-overflow that affects only the victim end host. Therefore, it is important to note that we do *not* aim to propose an alternative to existing detection approaches, but rather to complement them where they are less effective.

Our assumption is that the attacker's goal is to do one of the following: (a) inhibit or reduce the service provided by the network to its users (e.g., DoS attacks) or (b) modify services provided by the network (e.g., routing process or other basic services such as DNS). As mentioned above, we aim to detect all such attacks regardless of the specific techniques they employ or the protocol they use over the IP protocol.

Our approach may detect rare benign events that affect the network's QoS, such as a flash crowd, as anomalies. However, in section 5.7, we show that by using a simple method, our proposed NIDS can learn to ignore such benign anomalies with a very small cost of intrusion detection delay.

Our NIDS architecture identifies the location of the attack's effect, not the attack's traffic or its source. The rationale of this approach is based on the fact that the detection of the true source of a real-world attack demands elaborate forensic work conducted by a human expert. The findings or alerts of any NIDS are only the starting point to detecting the true source of the attack. This is especially true in the case of the common multi-stage attacks [6].

The proposed NIDS architecture is focused on intra-domain network settings, such as enterprise or ISP networks. In such a setting, the network operator has the ability to deploy the proposed distributed architecture. In addition, the operator has full knowledge of the network topology and the routes taken between every pair of end nodes. This knowledge is essential in order to deploy our proposed architecture efficiently.

1.2 One-Class Learning

One-class learning is a special case of machine learning whose main goal is to differentiate examples of the class of interest from all other examples. The one-class

classifier is trained from a training-set containing only the instances of that class. In network security, one-class classifiers most frequently train on the normal state of the network, i.e., they model the network’s normal state. There are two main features that make one-class classifiers attractive for network security. First, they do not require any labeled attack instances, which are very difficult and costly to attain and second, they can identify zero-day attacks, which are often the attacker’s weapon of choice.

1.3 One-Class Ensemble Learning

One of the contributions of this work is the application of meta learning ensemble to NIDS. The main idea behind this ensemble methodology is to weigh several individual classifiers (ensemble members) and to combine them via another classifier (combiner) to obtain a classifier that outperforms the ensemble members. Theoretically, an ensemble can benefit from any independent base-classifier that performs even slightly better than a random one (see the Condorcet Jury Theorem and [7]). Indeed, previous studies in supervised ensemble learning (e.g., [8]) show that combining classification models can produce a better classifier in terms of prediction accuracy.

In contrast to the research on supervised learning, progress in the theory of combining one-class classifiers has been limited. According to [9], up until 2008, this research field was relatively new and had not been thoroughly explored. In particular, in the setup of diverse ensemble members, only two combining methods were considered for one-class problems: the *fix-rule* [10], [11] and meta-learning [12] ensembles.

Meta-learning is a process of learning from basic classifiers (ensemble members); the inputs of the meta-learner are the outputs of the ensemble-member classifiers. The goal of meta-learning ensembles is to train a meta-model (meta-classifier) that will combine the ensemble members’ predictions into a single prediction. In order to create such ensembles, both the ensemble members and the meta-classifier need to be trained. Since the meta-classifier training requires already trained ensemble members, these must be trained first. The ensemble members are then used to produce outputs (classifications) from which the meta-level dataset (meta-dataset) is created. This dataset will be used for training the meta-classifier. The basic building blocks of meta-learning are the meta-features, which are measured properties of the ensemble members, e.g., an ensemble members’ predictions. A vector of meta-features comprises a meta-instance, i.e., meta-instance $\equiv \langle f_1^{meta}, \dots, f_k^{meta} \rangle$. A collection of meta-instances comprises the meta-training-set upon which the meta-classifier is trained.

Paper Outline

The rest of this paper is organized as follows. In Section 2 we present related work. In Section 3, we

introduce the proposed NIDS method. We then discuss the experimental setup and the network attacks used in the evaluation in Section 4 and present the results in Section 5. Finally, we close with conclusions in Section 6.

2 RELATED WORKS

In the past two decades, many anomaly-based NIDS schemes have been proposed. The common trend among these systems is that they model the network’s normal state by analyzing aspects of the production traffic, e.g., network flows [13], [14], [15], packet payload information [16], [17], [18], network event analysis [19], [20], [21] or management information base (MIB) aggregated information [22], [23], [24].

By depending solely on the production traffic (or its aggregations), of which they have no control, these NIDS take a passive approach and should hence be labeled “*passive-NIDS*.” The passive approach has many advantages like high data availability and simplicity. However, many drawbacks also exist. Sommer et al. [1] list five attributes of the network security domain that usually prohibit (passive) anomaly-based NIDS from being implemented or adopted in real networks. They argue that detecting attacks is a very different and more difficult task than the classic task of machine-learning. Their list of five attributes is as follows: First, “real-life” errors bear a very high cost in reality. Second, usually only a very limited training data is available. Third, there is a difference between the anomaly detector output and the operational meaning. Fourth, it is difficult to train a sound model of the network’s normal state because of the huge variance in the training data. Fifth, machine-learning NIDS cannot be evaluated in conditions sufficiently close to reality and therefore their benchmark results do not reflect their eventual performance on real networks.

In contrast to passive-NIDS, the active-NIDS approach, by which the NIDS relies on self-traffic incurred by probe sending, can overcome some of the aforementioned deficiencies. A fundamental property of the active-NIDS is that during the normal network operation, its probe features, such as *hop_count* and *average_round_trip_time*, are characterized by very low variability. This means that probes’ features are very predictable, thus can be modeled easily and effectively by training classifiers on limited size datasets, as we show in Section 5. While classification errors are not easy to avoid completely, maintaining the very costly false alarms at zero, while at the same time detecting every significant attack, is indeed possible, but at the cost of a detection time delay. In this study we demonstrate such a technique and measure its detection time delay (we refer to this as Time-to-Detect, denoted *TtD*).

Byzantine faults, which might occur due to unexpected network failures or topology changes, should

be detected by the NIDS if presenting a significant change from the network's normal state. We argue that these benign events should be addressed by the network operator and should not be counted as false alarms of the NIDS. In appendix 5.7, we demonstrate a method for reducing the detection of benign anomalies while still preserving the detection rate. The active-NIDS has full knowledge of the paths its probes travel during training time; therefore, when an anomaly occurs, it can localize the affected network devices by identifying the probes with anomalous features. Such a technique is given in Section 3.4.2. The anomaly localization feature provides the security specialist and the network operator with valuable information. Although this does not close the gap between anomaly detection output and operational meaning, it is a step closer to this goal.

Up until now, the active probing approach has been practiced mainly for network monitoring, fault localization and network diagnosis, e.g., [25], [26], [27]. Our survey found only two related studies. The first, by Barbhuiya et al. [28], presents a genuine NIDS, whereas the research by Barford et al. [5] is actually related to network QoS assurance, though is quite easy to translate for network-security purposes.

The active-NIDS studied by Barbhuiya et al. [28] sends address resolution protocol (ARP) probes to detect ARP spoofing attacks. The authors devised a formal model of the protocol state transitions with which they later detect anomalies. The main drawbacks of their method are that it is protocol-specific, namely, it is not sufficiently general to detect other classes of attacks and it protects the hosts only in the local network.

Barford et al. [5] also take the active probing approach but with the intentions of identifying network QoS anomalies and localizing anomalous links. Their ultimate goal is to detect and localize QoS anomalies that might occur on *any* existing path between *any* two measurement nodes. To do so, they must cover the entire network by a probing scheme. To avoid producing and analyzing $O(N^2)$ probes in each time unit, they limit the monitoring task to only k selected (with probability) paths in each time unit; since they assume that the anomalies are persistent, they are certain to detect them after finite time periods. Furthermore, they perform the anomaly detection and localization task in two stages; first an anomaly detection stage, followed by the anomaly localization stage.

While this approach works for QoS assurance, it is not entirely suitable for the network security domain, since network security attacks that cause link failures are intentional, malicious, and might be limited in time, while in operational networks, link failures tend to occur sporadically and are persistent.

Moreover, the two-phase detection and localization method has been criticized [29] as producing sub-optimal anomaly detection and localization perfor-

mance. An additional limitation of Barford et al.'s method is that they put no bound on the length of their probes, and by not doing so, they are usually required to send elevated numbers of probes to localize an anomalous link, in contrast to a short probing scheme, such as the one described in the present study.

3 THE PROPOSED METHOD

The new NIDS scheme, ACTIDS (Active Intrusion Detection System), is mainly characterized by five features: (1) dispatching of probe packets to generate network traffic, from which features are extracted; (2) hierarchical anomaly detection architecture, i.e., the network is partitioned into smaller disjointed sub-networks (a single autonomous anomaly classifier (local anomaly classifier) is linked with each network sub-network); (3) anomaly classifiers are trained on examples of the normal network state (i.e., *one-class*) so attack examples are not required during training; (4) anomaly detection and localization are performed simultaneously; and (5) in combining the predictions of the local anomaly classifiers, a state-of-the-art meta-learning ensemble is used.

3.1 Architecture

ACTIDS includes three main components: Agents, Sensors, and a Central Detection Server (CDS). The hierarchy is as follows. Each Sensor gathers information from multiple Agents, which are the elementary parts, and the CDS combines information from multiple Sensors. These three components are described in depth below.

Agent - lightweight software responsible for transmitting probe packets and extracting QoS statistics from incoming probe packets. The Agents are installed at selected hosts. The probe packets are standard IP packets which carry special protocol values in order to be distinguished from other packets at the network layer. Agents are linked to at least one Sensor.

Sensor - an anomaly detector overseeing a limited-size connected network section. During the setup phase (see 3.2), the network is partitioned into disjointed sections, each of which is assigned to a single Sensor. The Sensor, as can be seen in Figure 1, is made up of an Instance Creator module and a machine-learning anomaly classifier and is bound to Agents installed at its network section. The Instance Creator module continuously aggregates data from the bound Agents, and once every pre-defined time period, it produces an instance that is then classified by the anomaly classifier. The classification or anomaly score is a numerical value in the range of [0,1] which represents the likelihood of local anomaly and is outputted to the CDS, where it is combined with other Sensors' classifications.

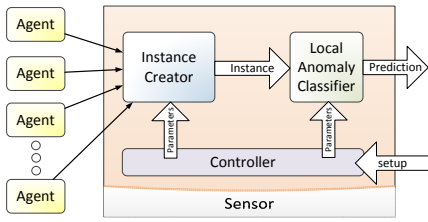

Fig. 1. The Sensor's conceptual architecture

Central Detection Server (CDS) - produces the global anomaly score, which indicates the security condition of the entire network. The CDS plays a role in all three states of the proposed NIDS. In the setup phase, the CDS has two functions. First, it determines the network partition, according to the *partition algorithm*; each partition holds a single Sensor. The CDS's second function during setup is to determine the probing scheme. During the training phase, the CDS's anomaly classifier is trained. Lastly, in the detection phase, the CDS produce a global anomaly score by combining anomaly scores produced by the Sensors.

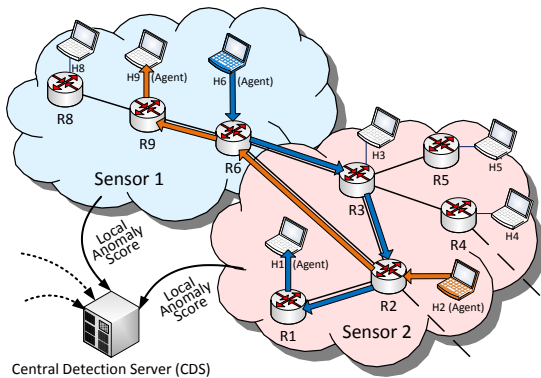

Fig. 2. Example of two probes, sent across two Sensors, which then send their corresponding local anomaly score to the CDS

ACTIDS has a three stage life cycle: setup, training, and prediction. All the aforementioned stages are fully automatic and require very limited user intervention. We now describe each of these stages.

3.2 Setup Phase

In the setup stage two pre-processes of ACTIDS are executed; the first determines the Sensors' partition while the second determines the probing scheme.

3.2.1 Local Anomaly Sensors

During the setup phase, the network is logically partitioned into sub-networks. A local anomaly detector (Sensor) is attached to each sub-network. Algorithm 1 establishes a set of disjoint Sensors, each of which contains up to *max_number_of_routers* routers.

Definition 1: (Probe). Probe is a special media that is sent between two Agents.

The Probes are used for extracting crude network features upon which anomalies are detected. Probes make a roundtrip, starting at the source Agent, traveling to the destination Agent at one of the adjacent Sensors, and then returning to the source. The roundtrip is necessary in order to avoid router time synchronization, which may be difficult to attain in real-life networks. A Probe can be made of any type of media which is appropriate for sending over the network, e.g., IP packet, ICMP packet or any application packet of choice. The source and destination hosts relate to different Sensors.

Definition 2: (Probe-Path). Probe-Path is a set of connected edges (v, e) which follow the shortest path between the Probe's source host and its destination host and back to the source host.

Definition 3: (Probe re-sending). Let T_{prs} denote the constant time interval between subsequent Probe re-sending.

3.2.2 Probe Dispatching Mechanism

The *Probing Mechanism* produces a list of Probes. Later, during the training and detection phases (the second and third stages of the proposed NIDS's life cycle, respectively), this Probe list is sent to enable Agents to measure statistics regarding the network's QoS. During the training and detecting stages, the Probes are re-sent once every fixed (configurable) period of time. A procedure for an automatic generation of a probing scheme is presented in Algorithm 2. We call this algorithm "the probing algorithm." The probing algorithm is the second and final algorithm related to the setup phase. The inputs for this algorithm are the Sensors' partition, a list of routers, and the Probe length, i.e., *probesLength*. The probing scheme algorithm follows three guidelines:

- 1) To increase the likelihood of detecting anomalies, Probe-Paths should cover as many of the network's edges as possible.
- 2) To reduce both Probe traffic and learning complexity, use as few Probes as possible.
- 3) To enable accurate detection of the anomaly source, Probe-Paths should be short, i.e., 4 or 6 edges.

These guidelines can be translated into an optimization problem in which we aim to cover all the network's edges with a minimal set of Probe-Paths over a bounded number of edges. A special case of this problem, in which no bound on the Probe-Paths' length exists, has been shown to be an instance of the NP-hard *Minimum Set Cover* problem [25]. However, covering all the network's edges is very likely to generate too much Probe traffic and increase the learning dimensionality, thus making the learning task too complex.

Our probing scheme uses only on the order of $O(|v|)$ Probe-Paths while attempting to cover most of the network devices. This is because each router sends, at most, a single Probe, whose path length is bound by the *pathLength* constant, as presented in Algorithm 2.

Such a probing scheme will generate sufficient information to detect attacks whose effects reach beyond the boundaries of a single Sensor. As the network attack affects a greater section of the network, and is therefore regarded as more severe from the perspective of the defender, the probability of the effect being captured by at least one Probe increases.

Algorithm 1: Partition the network into disjointed Sensors

Input: *NetworkTopology* : network's topology
Input: *max_routers* : the maximal number of routers in each Sensor
Output: *SensorsMap* : a list of Sensors
Routers \leftarrow ParseTopology (*NetworkTopology*)
SensorsMap \leftarrow \emptyset
foreach *r* in *Router* **do**
 Degree \leftarrow CalculateDegree (*r*)
Sort (*Routers*) by *Degree*;
while $|Routers| > 0$ **do**
 currentSensor \leftarrow createEmptySensor ()
 kernel \leftarrow deleteFirst (*Routers*);
 Add *Kernel* To *currentSensor*
 while $|currentSensor| \leq max_routers$ **do**
 nr \leftarrow DeleteNeighbor (*kernel*, *Routers*)
 Add *nr* To *currentSensor*
 Add *currentSensor* To *SensorsMap*

The *DeleteNeighbor(r,Routers)* routine extracts the neighbor router of *k* with the highest rank and deletes it from router group *Routers*.

Algorithm 2: Probe-Scheme Generation

Input: *RoutersMap*, *SensorsMap*, *probesLength*
Output: list of Probes
pl \leftarrow *probesLength*
ProbeList \leftarrow \emptyset
foreach *r* in *RouterMap* **do**
 srcS \leftarrow GetSensor (*r*, *SensorsMap*)
 Candidates \leftarrow RoutersAtDistance (*r*, *pl*)
 foreach *c* in *Candidates* **do**
 destS \leftarrow GetSensor (*c*, *SensorsMap*)
 if Not(*srcS*==*destS*) AND
 ExistProbeBetween(srcS,destS)=false **then**
 src \leftarrow *r*
 dest \leftarrow *c*
 ProbeList += New Probe(*src*, *dest*)
 end foreach

3.3 Training Phase

In this stage all the machine-learning models, i.e., the local anomaly detectors attached to the Sensors and the global anomaly classifier in the CDS, are trained. At the end of this stage, the proposed NIDS is ready for the detection phase. The training process comprises three distinct tasks: producing the training datasets, training the Sensors' classifiers, and training the global anomaly classifier. We now discuss each of these tasks.

Definition 4: (Classification Time). Let T_{cl} denote the constant time interval between behavior classifications of subsequent networks.

Prior to training the machine-learning-based classifiers, a set of appropriate training data is produced. This is achieved in several stages. First, the NIDS begins sending Probes across the network according to the pre-acquired Probe-Scheme. The Probe traffic is added to the network's normal chaotic traffic. As the Probes are re-sent once every T_{prs} during the entire training phase, they incur the traffic from which the Agents collect raw statistics. When an Agent receives a Probe, it extracts three raw features; *hop count*, *travel time*, and *num_lost_probes* and delivers them to the Sensor to which it is attached. The Sensor aggregates the received statistics until, once per T_{cl} ($T_{cl} \gg T_{prs}$), it computes the average and the variance of the data accumulated for the first two raw features, computes the *lost_probes percentage*, and constructs an instance. The instance is then added to the Sensor's private training-set. Next, the statistics at the Sensors are nullified and the process repeats until the end of the training phase, by which time all the training-sets contain the same number of instances. Table 1 presents the Sensors' training-set structure.

Next, when the Sensors' training-sets generation is done, the Sensors' classifiers are trained, each on its own private training-set. Lastly, ACTIDS uses the TUPSO ensemble scheme [12] to train the CDS's classifier, which is responsible for combining the Sensors' local anomaly score during the prediction phase.

Let $P_t^m = \langle p_{t,1}^m, \dots, p_{t,n}^m \rangle$ denote the vector containing the Sensors' predictions, p_1^m, \dots, p_n^m for time unit t , where n is the number of Sensors. TUPSO generates a special train-set for the CDS's combiner classifier by applying k dedicated aggregate functions (described in [12]), $f(\cdot)$, to P^m . Each such aggregation represents a single feature (i.e., column) in the combiner's train-set. Table 2 illustrates the general structure of the

	Probe: $R8 \rightarrow R2$...
Time Unit	Avg. Delay	Var. Delay	Avg. Hop Count	Var. Hop Count	% Lost Probes	...
1	$a_{1,1}$	$a_{1,2}$	$a_{1,3}$	$a_{1,4}$	$a_{1,5}$...
2	$a_{2,1}$	$a_{2,2}$	$a_{2,3}$	$a_{2,4}$	$a_{2,5}$...
...

TABLE 1

The Sensor's training-set structure. $a_{t,i}$ denotes the value of feature i at time unit t

Time Unit	$f_1(P_t^m)$	$f_2(P_t^m)$	$f_3(P_t^m)$...	$f_6(P_t^m)$	$f_7(P_t^m)$
1	$ma_{1,1}$	$ma_{1,2}$	$ma_{1,3}$...	$ma_{1,6}$	$ma_{1,7}$
2	$ma_{2,1}$	$ma_{2,2}$	$ma_{2,3}$...	$ma_{2,6}$	$ma_{2,7}$
...

TABLE 2

The training-set structure of the CDS's combiner

CDS's training-set. $ma_{t,i}$ denotes the value of feature i at time unit t .

3.4 Prediction Phase

The prediction phase represents the on-line state of the proposed NIDS. To generate the special traffic required by the proposed NIDS, the Agents continuously send Probes once every T_{prs} , according to the Probe-Scheme. Upon receiving the Probes, the Agents extract the same raw features as they did in the training phase. Each Agent adds the features it has extracted to the attached Sensor, where they are accumulated. Once every T_{cl} , each Sensor averages the accumulated values and generates a local instance. These instances are then classified by the Sensors' classifiers and their statistics are reset. Lastly, the predictions are combined by TUPSO, which outputs the ensemble prediction for time t , denoted as EP_t .

3.4.1 NIDS Output

The NIDS's ensemble output for time t , EP_t , is capable of classifying a snapshot of the network's behavior as it reflects the combined anomaly scores of the local Sensors. However, in situations where the NIDS Sensors are very sensitive, they may incur an erratic global prediction and thus induce false alarms (i.e., normal network behavior mistakenly classified as anomalous). To refine its classification quality, the presented NIDS uses the exponentially weighted moving average technique (EWMA) which produces smoother and conservative anomaly scores and, as a result reduces, the potential for false alarms. This, as we show in Section 5, is one of the factors responsible for incurring extremely low false-positive rates while at the same time allowing for a high detection rate. In a nutshell, the EWMA technique accumulates anomalous behavior evidence over time and, where there is sufficient evidence, will output an anomaly classification. The NIDS output, $NAS \in [0, 1]$, is computed as follows:

$$NAS_t = NAS_{t-1} + \xi * \Delta(t, p)$$

where $\Delta(t, p)$ is the difference between the weighted average of two time-series of the same length, $p/2$. The first series begins at $t - p$ and the second at $t - p/2$:

$$\Delta(t, p) = \frac{\sum_{i=0}^{\frac{p}{2}-1} (\frac{1}{\frac{p}{2}-i} * (EP_{t-\frac{p}{2}+i} - EP_{t-p+i}))}{\sum_{i=1}^{\frac{p}{2}} (\frac{1}{i})}$$

Variable t is a discrete time point with granularity t_{cl} , and p is the sum length of the time-series taken into consideration; $\xi \in \mathbb{R}^{>0}$ is the amplitude assigned to changes in the network behavior; NAS_t represents the likelihood of a network-wide anomaly in time t .

3.4.2 Localization Strategy

Identifying the location of an attack's effect is a task that the network operator has to deal with often. Finding the anomaly location can be highly valuable, particularly while the attack is on-going; this allows for measures which can be deployed to mitigate the attack. Identifying an attacks effect is also important in the post-attack period, as it may provide the forensic expert with helpful facts regarding the attacker's sources, such as attack propagation. In this section we explain how ACTIDS makes use of the hierarchical structure in order to pinpoint the location of attack's effect.

To identify the anomaly location, ACTIDS relies heavily on the independent ability of each Sensor to indicate the existence of a local anomaly. Once a Sensor detects anomalous behavior, it sends the CDS a computed (local) anomaly score along with a list of network components in the region of which it suspects has anomalous behavior. This list is produced by extracting the network components affecting the anomalous features. Next, the CDS processes the lists and produces a shortlist of suspected anomalous components.

Figure 3 exemplifies this for the case of R14 attacking R13. Assuming that, because of this attack, the values of three Probe features become anomalous: $R4 \rightarrow R20$, $R6 \rightarrow R13$ and $R28 \rightarrow R13$. This causes Sensors 2, 12, and 14 detect an anomaly. Each of these three Sensors will therefore compile a list of routers that have affected the Probes' values, i.e., the routers that exist in the path of the anomalous Probes. In our example, the reported lists contain: $\{R4, R13, R20\}$, $\{R28, R19, R13\}$, and $\{R6, R21, R13\}$ from Sensors S2, S12, and S14, respectively. Next, to find the anomalous network component(s), the CDS fuses these lists using a very simple rule: Let the maximal appearance of the network component be denoted as $maxApp$. It declares any network component in the reported lists that appears *more* than $maxApp/2$ as anomalous. In this example, R13 appears three times, while the remaining routers appear only once; therefore, only R13 is declared as anomalous. The above process is executed for every test instance; thus, on every classification, ACTIDS produces a list of network components suspected of being anomalous. The accuracy of this method depends on four factors: the number of Sensors, the length of the Probes, the anomaly detection accuracy of the Sensors, and lastly, the ability of the Sensor to discriminate between anomalous and normal features. Both the Sensors' size limit and the Probes' length were taken into

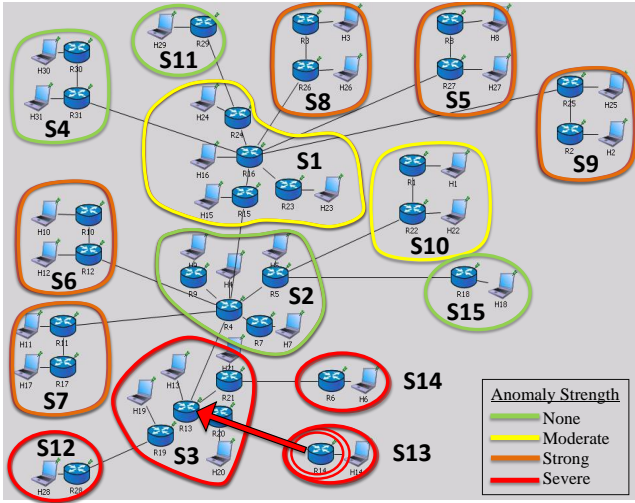

Fig. 3. Sensor scheme deployed on top of AS4755 network topology. In this example R13 is under attack. This attack incurs a network-wide anomaly detected in remote Sensors, such as S5 and S9

consideration in the design of ACTIDS, hence the limit of routers per Sensor and Probe-Path length were considered as well.

4 EXPERIMENTAL SETUP

In this section, we specify the conditions in which the proposed NIDS was investigated. First, we illustrate the network simulation used for executing the NIDS. Then, we describe the machine-learning algorithms that participated in the evaluation. Lastly, we present the performance metrics needed to measure the effectiveness of the NIDS.

The NIDS’s machine-learning modules were implemented within the WEKA machine-learning framework [4]. To evaluate the performance of the proposed NIDS, we used the OMNeT++ [30] simulation framework, which allows a network to be simulated with full IP stacks. We used real router-level ISP topologies, as mapped by the RocketFuel project [31]. Table 3 lists the ISP topologies used, which include between ten and several hundred routers. The traffic between the routers was generated based on the well-known gravity model [32]. In this model each router is randomly given a weight, and the average traffic volume between two routers is proportional to the product of their weights. The actual pattern of the generated traffic was based on the self-similar model, which is widely believed to be the model that best fits Internet traffic [33].

The simulation was executed for 4500 time units (TU); the simulation was run for 1020 TU before the NIDS was executed to ensure the OSPF converged, then it began to send probes at a rate of 25 per TU for the duration of the experiment, which was set to 3500 TU . The classification period, t_{cl} , was defined as 1 TU so that overall, the datasets (training-

Topology	Name	Routers	Links
AS1755	Ebone (Europe)	163	300
AS3257	Tiscali (Europe)	276	400
AS3356	Level3 (U.S.)	624	5,300
AS4755	VSNL (India)	11	12

TABLE 3

Properties of the autonomous systems used in the evaluation. Source: RocketFuel

and test-sets) contained 3480 instances. Since the Sensors contained differing numbers of data sources (i.e., number of Probes), their datasets varied by the number of features. Throughout the evaluation, we used $max_routers = 4$ and $probesLength = 4$ and a classification threshold $\Theta = 0.75$ over NAS , which was sufficiently high so as to produce zero false positives while maximizing the true-positive rate.

4.1 Attack Scenarios

In general, there are two ways for an attacker to harm the QoS of a network. The first way is to change the routes the normal production traffic takes. This way, the attacker may direct traffic through a narrow link or lengthen its route in order to increase the delay and the packet-loss the traffic experiences. The second way to harm the QoS of a network is to induce extra production traffic that would normally not have been generated. One example of this is a reflected SYN attack in which the attacker sends many spoofed SYN packets to various end hosts who respond with SYN-ACK packets. In this example, the extra traffic is induced by the attacker itself (SYN packets), as well as the victim end hosts (SYN-ACK packets). By inducing a high volume of traffic an attacker may exhaust the bandwidth of one or more links in the network.

We evaluated our NIDS only against attack scenarios of the first type, as it is considered more subtle and harder to detect. There are various ways for an attacker to implement such attacks. For example, he may advertise false routing advertisements in order to change the routing tables, he may poison a DNS cache in order to change the destination IP address of the traffic; or he may launch any application-specific impersonation attack in order to divert traffic to a false end host. From the network’s point of view, and consequently from our NIDS’s point of view, all such attacks have a similar effect, namely, traffic diversion.

To evaluate our NIDS’s effectiveness against traffic diversion attacks we executed two OPSF attacks, i.e., partially disconnecting and link-weight distortion attacks, and two DNS attack variants, i.e., DNS cache poisoning and authoritative DNS server poisoning (shown in Figure 4). The description of these four attack variants is given in [34]. These attacks are *currently* the most flexible and powerful way to achieve traffic diversion. Please note that ACTIDS is not a protocol-specific solution, i.e., it is not limited to the abovementioned protocols.

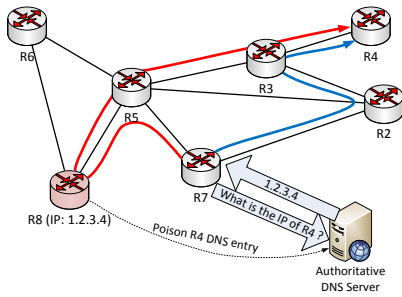

Fig. 4. An example of the authoritative DNS server poisoning attack, in which the affect of a single poisoned Authoritative DNS server entry is illustrated. The blue lines indicate the optimal routes, and the red lines indicate the routes that the packet would take due to the attack

4.2 Datasets

In each experiment related to the above mentioned attack scenarios, two datasets were generated: one training-set and one evaluation set. The training-set contained instances related to normal network behavior only, whereas the evaluation set contained instances related to normal and attacked periods (33.3% labeled “normal” and the remaining 66.67% labeled “attack”).

4.3 Classifiers

For evaluation purposes, we made use of three one-class algorithms: OC-PGA [35], 1-SVM [36], and AD-IFA (Attribute Distribution Function Approximation) [37]. We selected these base-classifiers because they represent the prominent families of one-class classifiers: density (OC-PGA) and boundary (OC-SVM). The OC-PGA algorithm is an adaptation for one-class learning from a well-known unsupervised algorithm [38] and the ADIFA algorithm is a univariate one-class anomaly detection algorithm based on meta-learning. In training the meta-classifier (the classifier of the global anomaly detector), we made use of ADIFA because it performed considerably better than the other learning algorithms.

4.4 Performance Metrics

In evaluating the NIDS, the following performance metrics were used: classification error rate, F-Score, area under the ROC curve (AUC), and Time-to-Detect and anomaly-localization score. These performance metrics provide sufficient information to assess the fitness of the proposed NIDS for detecting network anomalies originated by network attacks. Figure 5 depicts a network attack that begins at “attack start” time and ends after twelve T_{cl} time-units. Also shown is the corresponding predicted attack score produced by the NIDS (i.e., NAS).

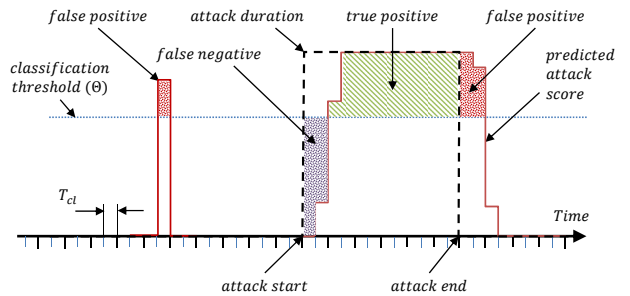

Fig. 5. A network attack surface and the corresponding predicted global network anomaly score over time

The classification *error rate* is the rate of incorrect predictions made by a classifier and is computed by the equation $error = (fp + fn)/(tp + tn + fp + fn)$, where tp , tn , fp and fn denote the number of true positive, true negative, false positive and false negative classifications of network behavior, respectively.

The *F-Score* is a performance measure used in many research domains such as data mining and information retrieval. It is defined by $F-Score = 2pr/(p + r)$, where p and r are classification precision and recall, respectively. To obtain a high score, both precision and recall must be high. Time-to-Detect (TtD) is a temporal metric that measures the time (in time-units, TU) from the commencement of a network attack to detection by the classifier (the NIDS). Usually there is a trade-off between TtD and false-positive rate (FPR). A low TtD (a good measure) typically comes at the price of a greater FPR, since the classifier is less able to distinguish between noise signals, which are erratic, and attack signals, which tend to be more stable.

The *Area under the ROC curve (AUC)* measures the effectiveness of the classifier. The ROC curve is a graph produced by plotting the true positive rate TPR (a.k.a *recall*) versus the false positive rate ($TPR = tp/(tp + fn)$, $FPR = fp/(fp + tn)$). The AUC value of the best possible classifier will be equal to unity. This would imply that it is possible to configure the classifier so that it will have 0% false positive and 100% true positive classifications. The worst possible binary classifier (obtained by flipping a coin for example) has AUC of 0.5. AUC is considered as an objective performance metric as it does not depend on the specific discrimination threshold used by the classifier.

Lastly, the anomaly-localization score (AL-Score) is an estimator that measures the extent to which the NIDS correctly identifies the source location of the anomaly. This measure is applicable for systems that can output a list of network components suspected of behaving anomalously. AL-Score is given by:

$$ALScore = 1 - \frac{\sum_{i=1}^{|An_{predicted}|} D(An_{predicted}^i, An_{real})}{\sum_{i=1}^{|v|} D(v_i, An_{real})}$$

where $D(v_i, U)$ computes the shortest path from node

v_i to the closest among nodes U ; $An_{predicted}^i$ is the i^{th} router in the group of routers predicted to be anomalous; and An_{real} is the group of victim routers.

5 EXPERIMENTAL RESULTS

In this section we present the empirical results, obtained by the proposed NIDS in the four of the above mentioned attack scenarios.

5.1 Probes Traffic Volume

The probes are the most important tool the proposed NIDS uses for identifying network anomalies. Unfortunately, they inevitably add some traffic to the network. By doing so, they might affect the NIDS measurements, or even, if a significant volume of probe traffic is produced, can reduce the network QoS. Therefore, it is imperative to quantify the probes' effect on the network. Fortunately, since the probes dispatching scheme, probes packet size, and the re-sending frequency remain constant during the entire on-line phase, computing the augmented network traffic volume is straightforward.

Table 4 summarizes the properties of the NIDS probes for the used network topologies. For calculating the probes traffic the following were assumed. A probe packet size is exactly 64 bytes, each probe is sent 25 times per second, and the bandwidth of every network link is 100Mb/s. The results indicate that the probes traffic volume is insignificant in terms of its capability to harm the network QoS.

Topology	#Probes (Probes/Sec)	Probe Traffic	
		(Bytes/Sec)	% of network's bandwidth
1755	125	8,000	0.004%
3257	75	4,800	0.005%
3356	1,375	88,000	0.007%
4755	350	22,400	0.006%

TABLE 4
Properties of the Probes traffic

5.2 Comparison with Passive Features

A basic assumption made in this study is that Probes' traffic features can yield a superior predictive model compared to passive-oriented feature sources. In this experiment we compared the Probes' features with two passive traffic features sources, i.e., link-based features and router-based features, with the intention of determining whether the primary assumption holds. In addition, we tested whether a mixture of feature sources can improve the NIDS classifiers' performance. As link-based features, *#bytes/sec* and *#packet/sec* features were extracted for each link, and as router-based features, three management-information-base (MIB) features were extracted for each router: *#packets_forwarded*, *#local_deliveries* and *#unroutable_packets*.

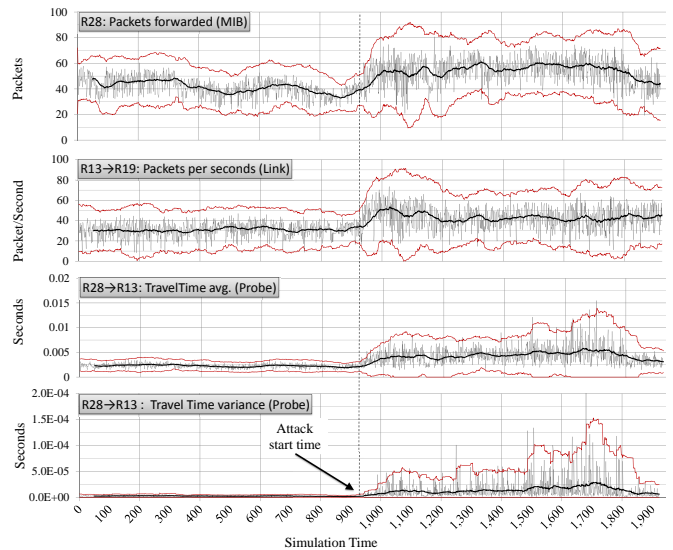

Fig. 6. Comparison between “passive” network features and “active” (probe) features

The NIDS was evaluated with both the partially disconnecting and the DNS cache poisoning attacks on the AS3356 and AS4755 network topology, respectively. We used only the ADIFA algorithm for training the Sensor classifiers.

Figure 6 presents a stacked plot of four aggregate features (each data-point is an average of 25 raw values), extracted by the proposed NIDS during a simulation run, in which a DNS cache poisoning attack was executed after 925 seconds. The upper most graph shows the *#packets_forwarded* feature, as measured in router R28, the second graph from the top shows the *#packets_forwarded* feature of the R13 ↔ R19 link, the third graph shows the R28 → R13 probe's round trip average *travel time*, and the graph at the bottom shows the variance of the *travel time* of the same probe. The data was captured at a simulation run, where a DNS cache poisoning attack was executed using the AS4755 topology. The gray graphs represent the raw data, the black bold graphs are the trend lines (using the moving average), and the red lines plot the three standard deviations range, computed from the raw value, over a historical time period of 60 seconds.

The graphs in Figure 6 lead to two conclusions. First, prior to the attack, both the MIB and Link features are much less stable compared to the two probe features. Second, the mean and variance of the probes raw data are much more affected by the attack, compared to both the MIB and Link raw features; while the average and variance of the raw MIB values increased due to the attack by 27% and 40% respectively, the average and variance of the probe's raw data (*travel time variance*) were increased by 426% and 1,680% respectively.

Continuing the comparison between the active and passive features, the next logical step is to study the classification performance of the proposed NIDS

Metric	Victim Router	Probes	Links	MIBs	Probe & Links	Probe & MIBs	Links & MIBs	All Features
FPR	R78	0.000	0.000	0.000	0.000	0.000	0.000	0.000
	R79	0.000	0.096	0.153	0.086	0.143	0.146	0.138
	R20	0.000	0.118	0.124	0.103	0.135	0.126	0.153
	R69	0.000	0.167	0.205	0.156	0.185	0.224	0.223
	R76	0.000	0.175	0.141	0.060	0.132	0.150	0.146
	Total	0.000	0.111	0.124	0.081	0.119	0.129	0.132
TPR	R78	0.990	0.968	0.722	0.988	0.989	0.901	0.988
	R79	0.989	0.664	0.989	0.989	0.988	0.988	0.986
	R20	0.885	0.998	0.990	0.994	0.990	0.990	0.990
	R69	0.329	0.787	0.342	0.723	0.346	0.606	0.591
	R76	0.989	0.993	0.990	0.991	0.990	0.988	0.989
	Total	0.836	0.882	0.806	0.937	0.861	0.894	0.909

TABLE 5

A comparison between ACTIDS features sources, based on TPR and FPR metrics

when using the different feature-set combinations. To this end, four scenarios of the partially-disconnecting attack were executed on the AS3356 topology, of which description is given in Table 6.

The results in Table 5 show that when trained using probe-based features, ACTIDS performed better compared to when trained on link-based or MIB-based features. A zero FPR was achieved only by using the probe-based features, while the other feature sources produced a considerably higher FPR.

In order to expand the generality of the above results, we plot ROC graphs by measuring the classification TPR and FPR of the proposed NIDS, for a range of classification thresholds. Figure 7 contains ROC graphs for the DNS cache poisoning attack, and Figure 8 contains ROC plots for the partially-disconnecting attack.

These ROC plots show that only the probe-feature group was able to produce a significant TPR (0.85 and 0.86 for the partially disconnecting and the DNS cache poisoning attacks, respectively) while, at the same time, inflicting no false positives at all.

These results are highly significant because they suggest that probe-based NIDS can successfully detect zero-day attacks, without needing to monitor the attack's traffic or the attack objective, such as the OSPF

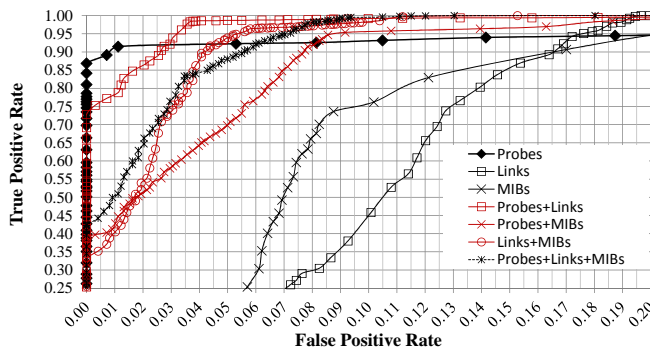

Fig. 7. ROC graphs for the DNS cache poisoning attack over the AS4755 topology

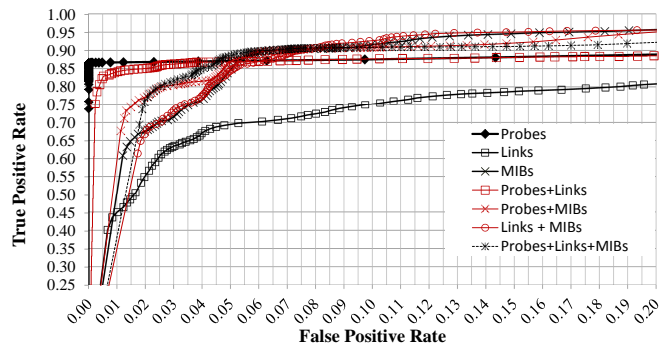

Fig. 8. ROC graphs for the partially-disconnecting attack over the AS3566 topology

routing table or the DNS cache. Interestingly, in both attack classes, the combination of probe features with either link or MIB features resulted with an inferior classification model, as long as zero FPR was required.

The following examines some additional aspects of the proposed NIDS. This examination is arranged in four sections, each of which deals with a different attack class.

5.3 Detecting Partially Disconnecting Attacks

In this experiment, ACTIDS is evaluated on attacks that logically disconnect half the victim(s) interfaces so that traffic can still pass or be routed through them on some interfaces. Hence the victim(s) are only partially “disconnected”. This experiment has two goals: first, to study the ability of the presented NIDS to detect network-based attacks with global effects; second, to determine which machine-learning algorithm is best suited for detecting the abovementioned attacks. Table 6 summarizes the attack scenarios and the attributes of their corresponding datasets.

Attack Scenarios		ACTIDS datasets	
Topology	Attacker → Victim	Sensors	Features Avg.
AS3257	R1 → R3, R1 → R6	4	12.5
AS1755	R2 → R11, R4 → R13, R9 → R15	4	22.5
AS4755	R14 → R13, R2 → R11, R2 → R16	15	12.06
AS3356	R75 → R78, R75 → R79 R77 → R20, R8 → R76	54	10.1

TABLE 6

Partially Disconnecting attack scenarios

The results in Table 7 show that ADIFA algorithm achieve a detection rate greater than 98% and that all three algorithms had no false-positive classifications: Their only classification errors were made during the attack period (false negative) when the NIDS was waiting to obtain “sufficient” global anomaly evidence.

Comparison of the two presented output functions reveals that EP (ensemble prediction output) is the most responsive measure for detecting attacks; however, it comes at the price of a higher FPR. In contrast, NAS has longer TtD than EP, but generates fewer

AS	Algorithm	TPR	FPR	% Error	F-Score	TtD	AL-Score
3257	1-SVM	0.981	0.000	0.014	0.990	49.000	0.946
	OC-PGA	0.980	0.000	0.014	0.990	50.500	0.945
	ADIFA	0.982	0.000	0.013	0.991	46.500	0.942
1755	1-SVM	0.981	0.000	0.014	0.990	49.000	0.951
	OC-PGA	0.980	0.000	0.014	0.990	51.000	0.950
	ADIFA	0.982	0.000	0.013	0.991	46.333	0.971
4755	1-SVM	0.981	0.000	0.014	0.990	49.000	0.982
	OC-PGA	0.681	0.000	0.229	0.710	49.667	0.980
	ADIFA	0.982	0.000	0.013	0.991	46.333	0.993
3356	1-SVM	0.981	0.000	0.014	0.990	48.667	0.988
	OC-PGA	0.793	0.000	0.149	0.856	48.333	0.986
	ADIFA	0.982	0.000	0.013	0.991	47.000	0.998
Total	1-SVM	0.981	0.000	0.014	0.990	48.909	0.969
	OC-PGE	0.847	0.000	0.110	0.877	49.818	0.967
	ADIFA	0.982	0.000	0.013	0.991	46.474	0.976
Total	<i>EP</i>	0.878	0.007	0.090	0.886	28.810	0.970
	<i>NAS</i>	0.934	0.000	0.047	0.951	48.492	

TABLE 7

Result table for the partially disconnecting attack class

false-positive classifications, which is usually a more important property for real NIDS.

5.4 Detecting Link Weight Distortion Attacks

Continuing further with the experimentation, we evaluate the proposed NIDS on the ‘Link Weight Distortion’ attack over three different scenarios. In the first two scenarios a single link weight is affected, whereas in the third, two links are simultaneously affected. Specifically, the implemented attack increased the target link’s weight (cost) by one orders of magnitude, to insure a global anomaly. The experiment was performed on the largest network topology, i.e., AS3356.

Affected Link	Algorithm	TPR	FPR	%Error	F-Score	TtD	AL-Score
R50↔ R79	1-SVM	0.000	0.000	0.667	0.0	n/a	n/a
	OC-PGA	0.913	0.000	0.062	0.955	33.0	0.984
	ADIFA	0.985	0.000	0.011	0.992	18.0	0.993
R79↔ R80	1-SVM	0.000	0.000	0.667	0.0	n/a	n/a
	OC-PGA	0.000	0.000	0.667	0.0	n/a	n/a
	ADIFA	0.468	0.000	0.379	0.637	136.0	0.994
R50↔ R79 R79↔ R80	1-SVM	0.000	0.000	0.667	0.0	n/a	n/a
	OC-PGA	0.990	0.000	0.667	0.995	25.0	0.984
	ADIFA	0.995	0.000	0.003	0.998	13.0	0.993

TABLE 8

Result table for the Link-Weight Distortion attack class

The results in Table 8 show that the Link Weight Distortion attack was, in general, harder to detect, when compared to the partially disconnecting attack. Consequently, when the proposed NIDS used the OC-PGA classifier, it did not detect one of the three attacks, and with the 1-SVM classifier it missed the attacks of all three scenarios. In contrast, when it used the ADIFA classifiers it detected all the attacks, and presented the best classification performance among the examined classifiers, with the shortest time-to-detect and the highest true positive detection rate.

5.5 Detecting DNS Cache Poisoning Attack

In this section we study the detection performance of the proposed NIDS on a simulated effect of the DNS cache poisoning. Specifically, we examine the

NIDS sensitivity using an increasing attack intensity, implemented by a series of experiments, each simulates an increased percentage of DNS poisoned entries at the victim routers. Five DNSs (routers) were subjected attacked during the experiment series to insure a substantial effect on the network’s QoS, even when only 10 percents of the DNS cache entries are poisoned. The experiment series was performed using the AS4755 topology. Router *R28* was used as the adversary, whereas the victims role was given to routers *R1*, *R2*, *R3*, *R8*, and *R9*.

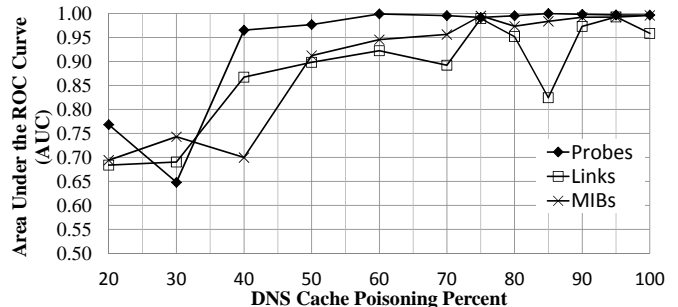

Fig. 9. AUC results for the proposed NIDS over different DNS cache poisoning percentage

The results in Figure 9 indicates that when the cache poisoning attack intensity was below 40 percent, non of the feature sets provided sufficient and robust information for intrusion detection. A change of trends started from an intensity around 40 to 50 percent. From this point and on, the Probe features incurred a detection AUC rate of above 0.95, which was greater than that of both the Link and MIB feature sets. It is important to note that until the attack reached the critical value of around 40 percents, the network QoS remained unharmed, as no evidence of increased delays, jitter or packet loss could be observed, either automatically or manually, from the extracted raw network data.

5.6 Detecting Authoritative DNS Server Poisoning Attacks

The current experiment studies the robustness of the proposed NIDS in detecting the authoritative DNS server poisoning attack. Unlike the DNS cache poisoning attack, every endpoint computer is subjected to the effect of the attack. Therefore, in order to generate a moderate, yet significant attack effect, only a single DNS entry was poisoned, so that only a small fraction of the global network traffic would be affected. In order to control the attack’s intensity, we limited the number of endpoints computers in the local network behind the victim router that are subjected to the attack. For example, if the local network contains 10 endpoint computers, and the attack intensity is 20 percents, only the traffic directed to a selected 2 endpoint-computers behind the victim router will be redirected

to the adversary. The experiment was conducted using the AS3257 topology, of which results are presented in Figure 10.

The results show that the QoS of the network had deteriorated, even when only 20 percents of the endpoint computers behind the victim router were affected. The greatest efficiency in the intrusion detection task was achieved by using the Probe features. In contrast, the Link features provided the least useful information among the three available feature sets. The MIB features provided a detection performance, similar to that achieved by the Probe features, only when the attack intensity was greater than 80 percents.

5.7 Handling Byzantine Faults

Byzantine Faults are benign network events in which some network elements perform significantly differently to that described by their nominal definition due to common reasons such as failed links, routers, switches or other network hardware. Naturally, these types of devices are monitored by the network service provider’s dedicated control channels, and therefore, detecting such events is not the focus of the present work. However, because these benign events might incur false detections for ACTIDS, we would like to study its ability to discriminate benign anomalies from anomalies that are the result of malicious activity.

The next experiment examines the extent to which ACTIDS detects benign anomalies and how it is trained to ignore such anomalies. To simulate benign routing anomalies, we incurred some link-failures during the simulation execution. To make the benign anomalies more interesting, the link-failures were designed to disconnect some critical links, i.e, non-redundant links between central routers, so that when executed the network would be strongly affected. Two links were chosen: $R76 \leftrightarrow R80$ and $R51 \leftrightarrow R80$. The links were disconnected at simulation time $TU_{start}=182, 2626$, and then were returned to full connectivity at $TU_{end}=1980$ and 3480 respectively.

In this experiment, performed over the AS3356 network, the NIDS’ classifiers were trained by the ADIFA

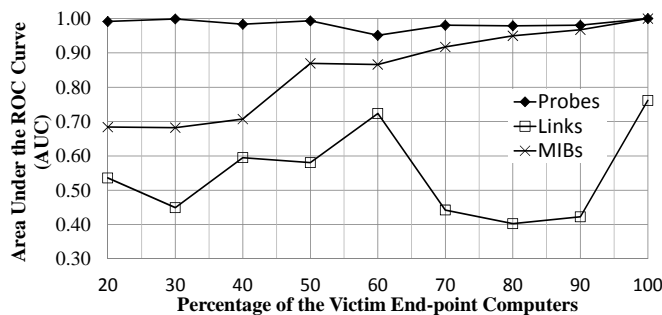

Fig. 10. AUC results for the proposed NIDS over different DNS cache poisoning percentage

algorithm on three sets of features: Probes (denoted P), Links (denoted L) and Probes + Links (denoted PL). Tr denotes a training-set containing normal network behavior instances, Tr_+ denotes training-sets that contain both normal and benign anomaly instances, and $valid.set$ represents a validation set incorporating both normal instances and attack (partially disconnecting) instances.

Training	Validation	Feature	FPR		TPR		FNR		TtD
			EP	NAS	EP	NAS	EP	NAS	
Tr	Tr_+	P	0.02	0	–	–	–	–	–
		L	0.26	0.19	–	–	–	–	–
		PL	0.72	0.67	–	–	–	–	–
Tr_+	Tr_+	P	0.01	0	–	–	–	–	–
		L	0.22	0.11	–	–	–	–	–
		PL	0.09	0.07	–	–	–	–	–
Tr_+	$valid.set$	P	0.02	0	1	0.99	0.00	0.01	28.5
		L	0.06	0	0.64	0.57	0.34	0.43	291.6
		PL	0.06	0	1	0.99	0.00	0.01	25.3

TABLE 9
The effect of Byzantine Faults on the NIDS classification performance

Table 9 shows that benign anomalies can indeed be falsely identified as network attacks and that the choice of training features has a large impact on the false detection rate. When trained with *Probes* features, ACTIDS had a 2% false detection rate; however, when trained with *Link* features, it had an imposing 26% false detection rate.

Continuing with the experiment, we explored how to mitigate the false detection. We believe that, by modeling benign anomalies as part of the normal state, ACTIDS will learn to ignore similar benign anomalies. For this reason, ACTIDS was trained upon both normal instances and link-failure instances. To evaluate the effect of these new conditions, ACTIDS was evaluated on normal and attack instances. The results are presented in the final three rows of Table 9. It appears that, in these new conditions, ACTIDS made much fewer detection errors, regardless of the feature-set used. Surprisingly, the results indicate that modeling benign anomalies, instead of rendering the NIDS less susceptible to any type of anomaly, did not harm the performance in any measurable way; the *recall* remained higher than 0.98 while maintaining a zero FPR and the *TtD* was not prolonged as expected.

6 SUMMARY AND CONCLUSIONS

In this paper we have presented a new active strategy for NIDS called ACTIDS. It detects and localizes network attacks by means of self-produced short-range probes, hierarchical anomaly detection and one-class ensemble learning.

We examined the proposed NIDS on 4 network topologies over 35 attack scenarios. The smallest network contained 9 routers, whereas the largest contained 82 routers. The experiments spanned five dimensions: attack class, features groups, topology, learning algorithm, and the NIDS output function. Our results show that the active approach can perform

better than the passive approach in detecting attacks that harm the QoS of the network. Experimented on the same platform, the active Probes features produced a considerably better classification performance, compared to the passive features. In particular, the Probe features incurred a zero false-detection rate (FPR), while achieving a true-detection rate (*recall*) of 85%. In order to produce such a high recall value, the NIDS, when trained on passive-related features, suffered from more than 10% false-detection classifications.

Another strength of the proposed NIDS is with its anomaly-localizing technique, which has been shown to be highly accurate and therefore, can serve as a powerful forensic tool for network operators and security experts.

The time taken for ACTIDS to detect a network attack was, on average, 46.8 seconds. This is an excellent result bearing in mind the zero-false-positives constraint and that network attacks, within the scope of this paper, are expected to last longer than an order of minutes.

REFERENCES

- [1] R. Sommer and V. Paxson, "Outside the closed world: On using machine learning for network intrusion detection," in *Security and Privacy (SP), 2010 IEEE Symposium on*, may 2010, pp. 305–316.
- [2] A. Lakhina, M. Crovella, and C. Diot, "Mining anomalies using traffic feature distributions," in *Proceedings of SIGCOMM, 2005*, pp. 217–228.
- [3] D. Brauckhoff, B. Tellenbach, A. Wagner, M. May, and A. Lakhina, "Impact of packet sampling on anomaly detection metrics," in *Proceedings of ACM SIGCOMM on Internet measurement, 2006*, pp. 159–164.
- [4] I. H. Witten and E. Frank, *Data Mining: Practical machine learning tools and techniques*, 2nd ed. San Francisco: Morgan Kaufmann, 2005.
- [5] P. Barford, N. Duffield, A. Ron, and J. Sommers, "Network performance anomaly detection and localization," in *INFOCOM 2009, IEEE*, april 2009, pp. 1377–1385.
- [6] D. D. Clark and S. Landau, "Untangling attribution," in *Workshop on Detering Cyberattacks: Informing Strategies and Developing Options for U.S. Policy*, 2010.
- [7] R. E. Schapire, "The strength of weak learnability," *Machine Learning*, vol. 5, pp. 197–227, 1990.
- [8] E. Menahem, L. Rokach, and Y. Elovici, "Troika - an improved stacking schema for classification tasks," *Inf. Sci.*, vol. 179, no. 24, pp. 4097–4122, 2009.
- [9] G. Giacinto, R. Perdisci, M. D. Rio, and F. Roli, "Intrusion detection in computer networks by a modular ensemble of one-class classifiers," *Information Fusion*, vol. 9, no. 1, pp. 69–82, 2008.
- [10] D. M. Tax and R. P. Duin, "Combining one-class classifiers," in *Proc. Multiple Classifier Systems, 2001*. Springer Verlag, 2001, pp. 299–308.
- [11] P. Juszczak and R. P. W. Duin, "Combining one-class classifiers to classify missing data," in *Multiple Classifier Systems, 2004*, pp. 92–101.
- [12] E. Menahem, L. Rokach, and Y. Elovici, "Combining one-class classifiers via meta-learning," *CoRR*, vol. abs/1112.5246, 2011.
- [13] W. Lee, S. J. Stolfo, P. K. Chan, E. Eskin, W. Fan, M. Miller, S. Hershkop, and J. Zhang, "Real time data mining-based intrusion detection," 2001.
- [14] O. Salem, S. Vaton, and A. Gravey, "A scalable, efficient and informative approach for anomaly-based intrusion detection systems: theory and practice," *Int. Journal of Network Management*, vol. 20, no. 5, pp. 271–293, 2010.
- [15] K. K. Gupta, B. Nath, and K. Ramamohanarao, "Layered approach using conditional random fields for intrusion detection," *IEEE Trans. Dependable Sec. Comput.*, vol. 7, no. 1, pp. 35–49, 2010.
- [16] H. Wang, D. Zhang, and K. G. Shin, "Change-point monitoring for the detection of dos attacks," *IEEE Trans. Dependable Sec. Comput.*, vol. 1, no. 4, pp. 193–208, 2004.
- [17] K. Hwang, M. Cai, Y. Chen, and M. Qin, "Hybrid intrusion detection with weighted signature generation over anomalous internet episodes," *IEEE Trans. Dependable Sec. Comput.*, vol. 4, no. 1, pp. 41–55, 2007.
- [18] N. Hubballi, S. Biswas, and S. Nandi, "Layered higher order n-grams for hardening payload based anomaly intrusion detection," in *ARES, 2010*, pp. 321–326.
- [19] R. Sommer, "Bro: An open source network intrusion detection system," in *DFN-Arbeitstagung über Kommunikationsnetze, 2003*, pp. 273–288.
- [20] J. Olivain and J. Goubault-Larrecq, "The orchids intrusion detection tool," in *CAV, 2005*, pp. 286–290.
- [21] F. Benali, N. Bennani, G. Gianini, and S. Cimato, "A distributed and privacy-preserving method for network intrusion detection," in *OTM Conferences (2), 2010*, pp. 861–875.
- [22] C.-M. Bao, "Intrusion detection based on one-class svm and snmp mib data," in *IAS, 2009*, pp. 346–349.
- [23] Y. F. Jou, F. Gong, J. G. Sargor, X. Wu, S. F. Wu, H. C. Chang, and F. Wang, "Design and implementation of a scalable intrusion detection system for the protection of network infrastructure," in *In DARPA Information Survivability Conference and Exposition, 2000*, pp. 25–27.
- [24] M. Nassar, R. State, and O. Festor, "A framework for monitoring sip enterprise networks," in *NSS, 2010*, pp. 1–8.
- [25] Y. Bejerano and R. Rastogi, "Robust monitoring of link delays and faults in ip networks," *IEEE/ACM Trans. Netw.*, vol. 14, no. 5, pp. 1092–1103, 2006.
- [26] L. Cheng, X. Qiu, L. Meng, Y. Qiao, and R. Boutaba, "Efficient active probing for fault diagnosis in large scale and noisy networks," in *INFOCOM, 2010*, pp. 2169–2177.
- [27] V. Singh, H. Schulzrinne, and K. Miao, "Dyswis: An architecture for automated diagnosis of networks," in *Network Operations and Management Symposium, 2008. NOMS 2008. IEEE*. IEEE, 2008, pp. 851–854.
- [28] F. A. Barbhuiya, S. Biswas, and S. Nandi, "An active des based ids for arp spoofing," in *SMC, 2011*, pp. 2743–2748.
- [29] E. Salhi, S. Lahoud, and B. Cousin, "Joint optimization of monitor location and network anomaly detection," in *LCN, 2010*, pp. 204–207.
- [30] A. Varga and R. Hornig, "An overview of the omnet++ simulation environment," in *SimuTools, 2008*, p. 60.
- [31] N. T. Spring, R. Mahajan, and D. Wetherall, "Measuring isp topologies with rocketfuel," in *SIGCOMM, 2002*, pp. 133–145.
- [32] J. P. Kowalski and B. Warfield, "Modelling traffic demand between nodes in a telecommunications network," in *in ATNAC, 1995*.
- [33] W. Leland, M. Taqqu, W. Willinger, and D. Wilson, "On the self-similar nature of ethernet traffic (extended version)," *Networking, IEEE/ACM Transactions on*, vol. 2, no. 1, pp. 1–15, feb 1994.
- [34] E. Menahem, G. Nakibly, and Y. Elovici, "Degrading the Network's Quality of Service via Traffic Diversion Attacks," <https://www.dropbox.com/s/tcz4g03xq844fae/TDA.pdf>, Tech. Rep., 12 2012.
- [35] A. Kontorovich, D. Hendler, and E. Menahem, "Metric anomaly detection via asymmetric risk minimization," in *SIMBAD, 2011*, pp. 17–30.
- [36] B. Schölkopf, J. C. Platt, J. Shawe-taylor, A. J. Smola, and R. C. Williamson, "Estimating the support of a high-dimensional distribution," 1999.
- [37] E. Menahem, A. Schlar, L. Rokach, and Y. Elovici, "Securing your transactions: Detecting anomalous patterns in xml documents," *CoRR*, vol. abs/1209.1797, 2012. [Online]. Available: <http://arxiv.org/abs/1209.1797>
- [38] E. M. Knorr and R. T. Ng, "A unified notion of outliers: Properties and computation," in *In Proc. of the International Conference on Knowledge Discovery and Data Mining*. AAAI Press, 1997, pp. 219–222.