

Microwave transmissions through superconducting coplanar waveguide resonators with different coupling configurations

ZHANG Si-Lei,^{1,2} LI Hai-Jie,¹ L. F. Wei*,^{1,3} FANG Yu-Rong,⁴ WANG Yi-Wen,¹
ZHOU Pin-Jia,¹ WEI Qiang,¹ CAO Chun-Hai,⁴ and XIONG Xiang-Zheng²

¹*Quantum Optoelectronics Laboratory,*

Southwest Jiaotong University, Chengdu 610031, China

²*Institute of Electromagnetic Field and Microwave Technology,*

Southwest Jiaotong University, Chengdu 610031, China

³*State Key Laboratory of Optoelectronic Materials Technologies,*

Sun Yat-sen University, Guangzhou 510275, China

⁴*Research Institute of Superconductor Electronics,*

Nanjing University, Nanjing 210093, China

(Dated: October 31, 2018)

Abstract

We design and fabricate two types of superconducting niobium coplanar waveguide microwave resonators with different coupling capacitors on high purity Si substrates. Their microwave transmissions are measured at the temperatures of 20 mK. It is found that these two types of resonators possess significantly-different loaded quality factors; one is 5.6×10^3 , and the other is 4.0×10^4 . The measured data are fitted well by classical ABCD matrix approach. We found that the transmission peak deviates from the standard Lorentzian with a frequency broadening.

PACS number(s): 84.40.Az, 74.78.Na, 85.25.Am

* weilianfu@gmail.com

In recent years much research attention has been paid to superconducting coplanar waveguide (SCPW) resonators due to their easy fabrications and many potential applications. A typical example is for the kinetic inductance detectors[1], which can work in optical-, UV-, and X-ray ranges[1–5]. Other applications include bifurcation- [6] and parametric amplification[7–9], as well as solid-state quantum computation[10, 11]. Technologically, CPW resonators can be easily fabricated due to their simple single-layer film structures: Their center strips and the relevant grounds are made in the same planes with the same material. Therefore, they are very convenient to be integrated into various parallel devices.

Usually, quasi-TEM modes propagate along the CPWs with sufficiently-narrow center strips. For the practical applications, two types of CPW resonators are mainly considered. The $\lambda/4$ shorted CPW resonators, one side is coupled to the feed line for measurement and the other side is shorted directly, are mainly used for kinetic inductance detectors. While, the $\lambda/2$ opened CPW resonators are mainly used in quantum information, solid-state quantum optics, and parametric amplifiers, etc.. In these structures, the resonators can be coupled outside via various capacitive configurations, such as finger, gap[12], and overlap ones, respectively. In this paper, we experimentally demonstrated the $\lambda/2$ opened Nb SCPW resonators with two types of coupled capacitors. By using the standard vector network analyzer we measured their microwave transmission coefficients S_{21} at low temperature 20 mK and obtained very different transport properties, which should be useful for the further applications.

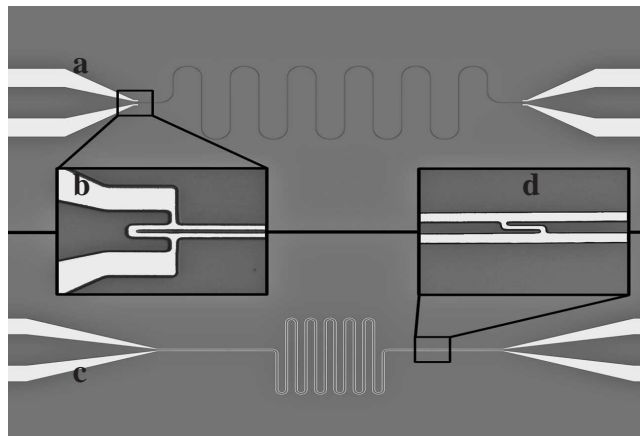

Fig. 1. The demonstrations of $\lambda/2$ Nb CPW resonators with different coupling configurations. (a) The resonator couples outside via two overlap capacitors shown in (b). (c) The resonator couples outside via two finger capacitors shown in (d). Here, the white region represents the applied Si substrates, and the grey region is the deposited metallization on the substrate.

The two types of Nb $\lambda/2$ CPW resonators designed and fabricated are shown in Fig. 1. Where, both of the resonators were fabricated on a high-purity Si wafer. The thickness of the Nb films deposited (by sputtering method) on the Si substrate is about $0.16 \mu\text{m}$, and then the desired structures are produced by the photolithographic technology. For the first CPW resonator (a), the center conductor has a width of $5 \mu\text{m}$, the gap between the center conductor and ground plane is also $5 \mu\text{m}$, and the length of the meandering resonator is $L_1 = 19.088\text{mm}$. The length of the coupling finger capacitors (b) at input/output ports is $L_f = 35 \mu\text{m}$, and the width d_1 of finger and the gap s_1 of the center conductor separated from ground plans is the same as the width w_1 of the center conductor, i.e., $s_1 = d_1 = w_1 = 5 \mu\text{m}$. While, the second CPW resonator shown in Fig. 1(c) has the relevant parameters: $L_2 = 18.258\text{mm}$, $w_2 = 20 \mu\text{m}$, $s_2 = 15 \mu\text{m}$, $d_2 = 7.5 \mu\text{m}$, the gap between the two fingers is $5 \mu\text{m}$, and the length of finger is $50 \mu\text{m}$.

The microwave transmissions through the resonators are measured in a ^3He - ^4He dilution refrigerator at the base temperature of 20mK . We use a 14GHz Agilent E5071C vector network analyzer (VNA) to measure the transmitted coefficient S_{21} (see Fig. 2). In order to avoid various non-linear effects, the two resonators are driven respectively by -60dBm and -50dBm input power. Theoretically, the fundamental frequency f of a $\lambda/2$ resonator can be evaluated as

$$f = \frac{c}{\sqrt{\epsilon_{eff}}} \frac{1}{2L}, \quad (1)$$

where c is speed of electromagnetic wave in vacuum, ϵ_{eff} is the effective permittivity (which is the function of the CPW geometry and the relative permittivity ϵ_r of substrate). And, $L = \lambda/2$ is the length of the resonator.

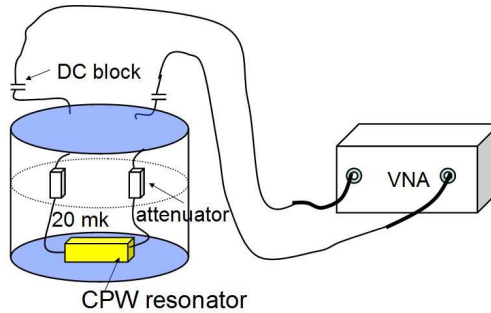

Fig. 2. Schematic diagram of the our low-temperature microwave measurement system. Gray boxes represent the attenuators.

The loaded quality factory Q_L of the resonator can be obtained by measuring its transmission coefficient S_{21} (dB), i.e., $Q_L = f_0/\Delta f$ with f_0 is the measured resonant frequency and Δf the 3dB bandwidth of the transmitted peak. Physically, the quality factory Q_L can also be expressed by

$$\frac{1}{Q_L} = \frac{1}{Q_{ext}} + \frac{1}{Q_{int}}, \quad (2)$$

with

$$Q_{ext} = \frac{\omega_0 R' C}{2}, \quad R' = \frac{1 + \omega_0^2 C_c^2 Z_L^2}{\omega_0^2 C_c^2 Z_L}, \quad \omega_0 = 2\pi f_0, \quad (3)$$

describing the influence from the outsides[13], and

$$Q_{int} = \frac{\pi}{2\alpha L}, \quad (4)$$

the internal losses. Above, C_c , α is the coupling capacitance and the internal losses of the resonator, respectively. Also, $Z_L = 50\Omega$ is the characteristic impedance of outside the microwave lines. Experimentally, the coupling coefficient $g = Q_{int}/Q_{ext}$, between the resonator and the microwave feed line[14], can be determined by observing the insertion loss of the resonator (i.e., the declination of peak from unity)[13]:

$$L_0 = -20 \log\left(\frac{g}{g+1}\right). \quad (5)$$

Here, $g = 1$, $g > 1$, and $g < 1$ refer to critically coupled, overcoupled, and undercoupled, respectively. Our measurements show that both of the two CPW resonators measured here are undercoupled. Furthermore, from Eqs. (2) and (5) and also the measured Q_L we can deliver the Q_{int} - and Q_{ext} parameters. Next, we can calculate the coupling capacitance C_c and the internal loss α .

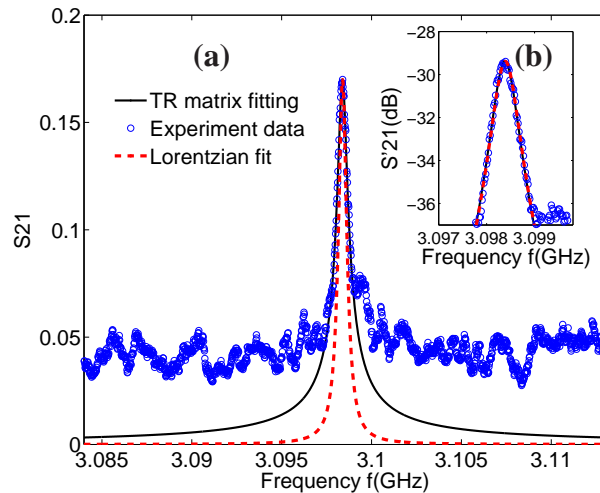

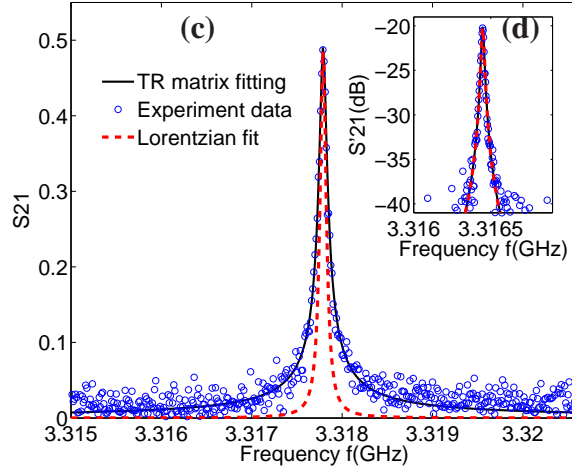

Fig. 3. Amplitude of the measured transmission coefficients S_{21} through: (a) the first $\lambda/2$ resonator and its dB format (b); (c) the second $\lambda/2$ resonator and its dB format (d). Here, the blue points are the measured data, and the black and red curves are fitted results by using transmission matrix (TR) theory and Lorentzian line shape. The data indicate the manifest background noise at the points deviated obviously from the resonance.

The measured S_{21} parameter can be fitted by the usual transmission ABCD matrix theory[14], i.e.,

$$S_{21} = \frac{2}{A + B/Z_L + CZ_L + D}. \quad (6)$$

Here, the ABCD parameters are determined by the equation

$$\begin{pmatrix} A & B \\ C & D \end{pmatrix} = T_z T_{cpw} T_z, \quad (7)$$

with

$$T_z = \begin{pmatrix} 1 & (j\omega C_c)^{-1} \\ 0 & 1 \end{pmatrix}, \quad \omega = 2\pi f, \quad (8)$$

and

$$T_{cpw} = \begin{pmatrix} \cos(\beta L) & jZ_{cpw} \sin(\beta L) \\ j(Z_{cpw})^{-1} \sin(\beta L) & \cos(\beta L) \end{pmatrix}. \quad (9)$$

Where, j is the imaginary unit, $\beta = \omega/v_p$, $v_p = 1/\sqrt{L_l C_l}$, and $Z_{cpw} = \sqrt{L_l/C_l}$ is the characteristic impedance with L_l , C_l being the inductance and capacitance per unit, respectively. Note that,

for the present case CPW has non-zero loss and thus β in Eq. (6) should be replaced by $(\alpha + j\beta)/j$. Practically, L_l and C_l can be calculated by using the so-called conformal techniques[15, 16]:

$$L_l = \frac{\mu_0}{4} \frac{K(k')}{K(k)}, C_l = 4\varepsilon_0\varepsilon_{eff} \frac{K(k)}{K(k')}, \quad (10)$$

where $\mu_0 = 4\pi \times 10^{-7}$ H/m and $\varepsilon_0 = 8.85 \times 10^{-12}$ F/m are the permeability and permittivity of free space, respectively. Also, $\varepsilon_{eff} = (\varepsilon_r + 1)/2$ with $\varepsilon_r = 11.9$ for the Si substrate. And, $K(k)$ represents the first kind complete elliptic integral with

$$k = \frac{w}{w + 2s}, k' = \sqrt{1 - k^2}. \quad (11)$$

With the above relations and the experimental data, we obtained $C_l \approx 1.46 \times 10^{-10}$ F/m for the first resonator, and $C_l \approx 1.58 \times 10^{-10}$ F/m for the second resonator.

Take into account cable losses (which is measured as 14dB), the L_0 in equation (5) is practically not the real insertion loss of the CPW resonator. We can also change Eq. (6) into the usual logarithmic units(dB), i.e., $S'_{21} = 20 \log_{10} |S_{21}|$ (dB). Consequently, C_c for each resonators can also be fitted by using the least-square method, and the results are listed in Table I. It is shown that, the fitted and the above calculation based Eq. (3) of the coupling capacitance C_c agree well; the deviations $\delta C_c = C'_c - C_c$ of the fitted C'_c compared to the theoretical calculations C_c are really small, e.g., $\delta C_c = -0.14\%$ for the first resonator and $\delta C_c = -0.5\%$ for the second resonator.

TABLE I: Main parameters of the two CPW resonators: f_0 and Q_L are the measured resonant frequency and the loaded quality factor, respectively. C_c is the fitted coupling capacitance.

Type	f_0 (GHz)	C_c (fF)	Q_L
1	3.09839	4.66	5.6×10^3
2	3.31779	2.90	4.0×10^4

Finally, we fit the peak shape of the measured S_{21} parameters by Lorentzian function

$$S_{21}(\omega) = A_0 \frac{(\omega_0/2Q_L)^2}{(\omega - \omega_0)^2 + (\omega_0/2Q_L)^2}, \quad (12)$$

with A_0 being the measured value of the S_{21} parameters at their the resonance points. Physically, A_0 represents how much power transport from one port to another in percentage so that we must minus the cable losses and insertion loss. Certainly, $A_0 = 1$ refers to the full power transmission.

It is seen from Fig. 3 that, the measured peak shape deviates the standard Lorentzian shape with certain frequency broadenings.

In conclusion, we have designed and fabricated two types of Nb $\lambda/2$ symmetrically coupled CPW resonators and measured their microwave transmission properties at the temperature of 20 mk for lower input powers. The measured data around the resonant points have been fitted well by using the usual ABCD matrix model and the relevant parameter such as the coupling capacitance C_c of the CPW resonators were determined. It was found that the measured transmission peak were not the standard Lorentzian shape. The reason of the found frequency broadenings would be investigated in detail in future. Finally, we found that the background noise is dominant at the non-resonant points, which should be further suppressed by using the further filtering technique.

Acknowledgements: This work was Supported by the National Natural Science Foundation of China under Grant Nos. 11174373, 11204249, and the National Fundamental Research Program of China, through Grant No. 2010CB923104. We thank Profs. Yu Yang and Wu Pei-Heng for kindly help and discussions.

-
- [1] P. K. Day, H. G. LeDuc, B. A. mazin, A. Vayonakis, J. Zmuidzinas 2003 *Nature* **425** 817
 - [2] B. A. Mazin, P. K. Day, H. G. LeDuc, A. Vayonakis, and J.Zmuidzinas 2002 *Proc. SPIE* **4849** 283.
 - [3] J. Zmuidzinas and P. L. Richards, 2004 *Proc. IEEE* **92** 1597.
 - [4] B. A. Mazin, M. E. Eckart, B. Bumble, S. Golwala, P. Day, J. Gao, and J. Zmuidzinas 2008 *J. Low Temp. Phys.* **151** 537.
 - [5] G. Vardulakis, S. Withington, D. J. Goldie, and D. M. Glowacka 2008 *Meas. Sci. Technol* **19** 015509.
 - [6] I. Siddiqi, R. Vijay, F. Pierre, C. M. Wilson, M. metcalfe, C. Rigetti, L. Frunzio, and M. H. Devoret 2004 *Phys. Rev. Lett* **93** 207002.
 - [7] E. Tholén, A. Ergül, E. Doherty, F. weber, F. Grégis, D. Haviland, 2007 *Appl. Phys. Lett* **90** 253509 .
 - [8] B. Yurke, L. R. Corruccini, P. G. Kaminsky, L. W. Rupp, A. D. Smith, A. H. Silver, R. W. Simon, and E. A. Whittaker, 1989 *Phys. Rev. A* **39** 2519.
 - [9] M. Castellanos-Beltran, and K. Lehnert 2007 *Appl. Phys. Lett* **91** 083509.
 - [10] H. L. Frunzio, A. Wallraff, D. Schuster, J. Majer, and R. Schoelkopf 2005 *IEEE Trans. Appl. Supercond.* **15** 860.
 - [11] M. Zhang and L. F. Wei, 2012 *CHIN. PHYS. LETT.* **29** 080301.

- [12] N. Zhao, S. J. Liu, H. Li, F. T. Li, W. Chen, 2012 *CHIN. PHYS. LETT.* **29** 088401.
- [13] M. Göppl, A. Fragner, M. Baur, R. Bianchetti, S. Filipp, J. M. Fink, P. J. Leek, G. Puebla, L. Steffen, and A. Wallraff, 2008 *J. Appl. Phys.* **104** 113904 .
- [14] D. M. Pozar, Microwave Engineering (Addison-Wesley Publishing Company, 1993).
- [15] S. Gevorgian, L. J. P. Linnser, and E. L. Kollberg 1995 *IEEE Trans. Microwave Theory Techn* **43(2)** 772
- [16] K. Watanabe, K. Yoshida, T. Aoki, and S. Kohjiro 1994 *Jap.J. Appl. Phys* **33** 5708