

VECTORIAL SOLUTIONS TO LIST MULTICOLORING PROBLEMS ON GRAPHS

YVES AUBRY, JEAN-CHRISTOPHE GODIN AND OLIVIER TOGNI

ABSTRACT. For a graph G with a given list assignment L on the vertices, we give an algebraical description of the set of all weights w such that G is (L, w) -colorable, called permissible weights. Moreover, for a graph G with a given list L and a given permissible weight w , we describe the set of all (L, w) -colorings of G . By the way, we solve the *channel assignment problem*. Furthermore, we describe the set of solutions to the *on call problem*: when w is not a permissible weight, we find all the nearest permissible weights w' . Finally, we give a solution to the non-recoloring problem keeping a given subcoloring.

1. INTRODUCTION

It is convenient to model cellular data and communication networks as graphs with each node representing a base station in a cell in the network and edges representing geographical adjacency of cells. Moreover, we associate to each vertex in the graph a set of calls in the cell served by the node corresponding to this vertex.

The *channel assignment problem* (see [8], [7] and [6]) is, at a given time instant, to assign a number $w(v)$ of channels to each node v in the network in such a way that co-channel interference constraints are respected, and the total number of channels used over all nodes in the network is minimized.

The problem is related to the following graph multicoloring problem: for a graph G with a given list assignment L , find the weights w such that G is (L, w) -colorable (see below for a precise definition of colorability). We will call such a weight w a *permissible weight*.

The purpose of this paper is to describe the set of all permissible weights w and then to give a construction of all (L, w) -colorings of G . In particular we solve the channel assignment problem which can be seen as: for a given graph G and a given weight w of G , find the weighted chromatic number $\chi(G, w)$ and furthermore find an $(\mathcal{L}_{\chi(G, w)}, w)$ -coloring of G (where $\mathcal{L}_{\chi(G, w)}(v) = \{1, 2, \dots, \chi(G, w)\}$ for every vertex v of G).

Additionally, the description of the set of all permissible weights enable us to solve the *on call problem*: when w is not a permissible weight, we find all the nearest permissible weights w' . This is the situation we meet when the network is exceptionally saturated as for the December 31st.

Finally, we consider the *non-recoloring problem* which arises when we want to extend a pre-coloring.

Date: October 15, 2018.

2010 Mathematics Subject Classification. 05C15, 05C38.

Key words and phrases. weighted graph, coloration, channel assignment problem.

Note that although all our proofs are constructive (and hence algorithms can be derived from them), the purpose of the present paper is not to compete with existing graph coloring algorithms such as those of Byskov [1, 2] for the unweighted case or the one of Caramia and Dell’Olmo [4] that computes the weighted chromatic number. Our setting is more ambitious since we consider the list coloring problem on weighted graphs, for which, to our knowledge, no general algorithm exists.

The paper is organized as follows. We develop a vectorial point of view in section 2. In particular for any color x arising in L we introduce the induced subgraph G^x of G whose vertices are those which have x as a color in their list. After introducing a partial order in \mathbb{N}^n , we define hyperrectangles built on a finite set of vectors. Then, we define the set $\vec{W}_{max}(G, L)$ of a graph G with a given list L : it is the set of sums of the maximal independent vectors of all the subgraphs G^x . This set will be a fundamental object in our results because it will be shown that this is the set of weight-vectors \vec{w} which give a maximal (L, w) -coloring of G . In Section 3 we consider a graph G with a given list L and a permissible weight w , and we describe the set $\mathcal{C}(G, L, w)$ of all (L, w) -colorings of G . It gives an explicit answer to the channel assignment problem as shown in Section 5. Then, Section 4 is devoted to the second main result, namely, for a graph G with a given list L , the characterization of the set $\vec{W}(G, L)$ of permissible weight-vectors \vec{w} (i.e. such that G is (L, w) -colorable). We prove (Theorem 7) that $\vec{W}(G, L)$ is the hyperrectangle of $\vec{W}_{max}(G, L)$. Section 6 is concerned with the *on call problem*. We describe the set of weights which give an answer to this problem. Section 7 focuses on the non-recoloring problem and Section 8 deals with some algorithmic considerations.

In the paper, all the graphs are simple, undirected and with a finite number of vertices.

If G is a graph, we denote by $V(G)$ the set of its vertices and by $E(G)$ the set of its edges.

A list assignment (called simply a list) of G is a map $L : V(G) \rightarrow \mathcal{P}(\mathbb{N})$: to each vertex v of G , we associate a finite set of integers which can be viewed as possible colors that can be chosen on v .

If a is an integer ≥ 1 , we define the a -uniform list \mathcal{L}_a of G by: for every vertex v of G ,

$$\mathcal{L}_a(v) = \{1, 2, \dots, a\}.$$

A weight of G is a map $w : V(G) \rightarrow \mathbb{N}$: to each vertex v of G , we associate an integer which can be viewed as the number of wanted colors on v .

The cardinal of a finite set A will be denoted by $|A|$.

We recall in the next definition what we mean exactly by an (L, w) -coloring of a graph, the central notion of this paper.

Definition 1. *Let G be a graph with a given list L and a given weight w . An (L, w) -coloring C of a graph G is a map C that associate to each*

vertex v exactly $w(v)$ colors from $L(v)$ and such that adjacent vertices receive disjoint color sets, i.e. for all $v \in V(G)$:

$$C(v) \subset L(v) , |C(v)| = w(v)$$

and for all $vv' \in E(G)$:

$$C(v) \cap C(v') = \emptyset .$$

We say that G is (L, w) -colorable if there exists an (L, w) -coloring of G .

2. A VECTORIAL POINT OF VIEW

When dealing with graphs with n vertices, we will work with vectors with integer coordinates in the vector space \mathbb{R}^n .

2.1. The vectorial decomposition. For any $n \in \mathbb{N}$, let us set

$$\mathbb{N}^n := \mathbb{N}\vec{e}_1 + \dots + \mathbb{N}\vec{e}_n$$

where $(\vec{e}_i)_{1 \leq i \leq n}$ is a basis of the \mathbb{R} -vector space \mathbb{R}^n . For any vector $\vec{x} = \sum_{i=1}^n x_i \vec{e}_i$ we consider the norm $\|\vec{x}\| = \sum_{i=1}^n x_i$.

Let G be a graph with n vertices v_1, \dots, v_n , let L be a list of G and let w be a weight of G . Let us introduce some notation.

For any subset N of the set $V(G)$ of vertices of G , we associate the vector

$$\vec{N} = \sum_{i=1}^n \lambda_i \vec{e}_i \in \mathbb{N}^n$$

defined by: $\lambda_i = 1$ if $v_i \in N$ and 0 if $v_i \notin N$.

We define the set of all colors of L , by:

$$\bar{L} := \bigcup_{v \in V(G)} L(v) ,$$

and we define $\tilde{L} \in (\mathcal{P}(\mathbb{N}))^n$ the n -tuple of sets:

$$\tilde{L} := (L(v_1), \dots, L(v_n)).$$

For any list L' of G , we define the union-list $\tilde{L} \tilde{\cup} L'$, by:

$$\tilde{L} \tilde{\cup} L' := (L(v_1) \cup L'(v_1), \dots, L(v_n) \cup L'(v_n)).$$

For any (L, w) -coloring C of G , we define its weight-vector $\vec{w}(C) \in \mathbb{N}^n$ by:

$$\vec{w}(C) := \sum_{i=1}^n |C(v_i)| \vec{e}_i = \sum_{i=1}^n w(v_i) \vec{e}_i.$$

Definition 2. For any color $x \in \bar{L}$ and any (L, w) -coloring C of G , we define the x -color sublist C^x as the list of the graph G defined by: for any $v_i \in V(G)$, $C^x(v_i) = \{x\}$ if $x \in C(v_i)$, and $C^x(v_i) = \emptyset$ otherwise.

The following proposition gives the decomposition of any coloring in terms of its x -color sublists.

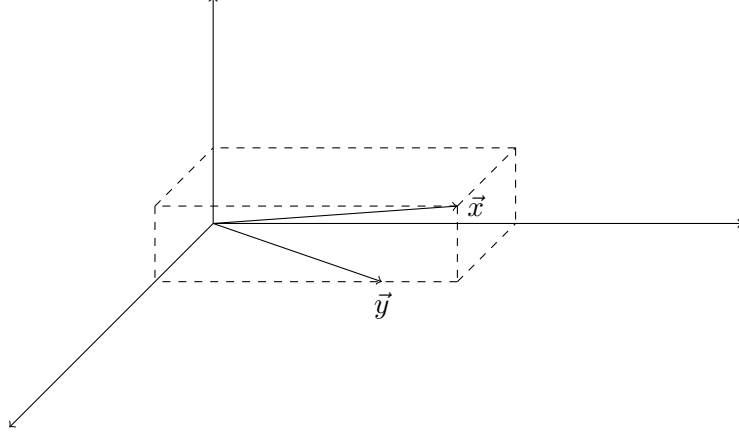

FIGURE 1. A vector \vec{y} in the hyperrectangle of \vec{x} .

Proposition 3. *For any graph G , any list L of G and any weight w of G , if C is an (L, w) -coloring of G , then:*

$$\tilde{C} = \bigcup_{x \in \bar{L}} \tilde{C}^x, \text{ and } \vec{w}(C) = \sum_{x \in \bar{L}} \vec{w}(C^x).$$

Proof. For any color $x \in \bar{L}$, consider the x -color sublist C^x of the graph G defined above. By construction we have, for any vertex $v \in V(G)$, $C(v) = \bigcup_{x \in \bar{L}} C^x(v)$, therefore $\tilde{C} = \bigcup_{x \in \bar{L}} \tilde{C}^x$. For any $x, y \in \bar{L}$ such that $x \neq y$, we have for any vertex $v \in V(G)$, $C^x(v) \cap C^y(v) = \emptyset$, therefore $\vec{w}(C) = \sum_{x \in \bar{L}} \vec{w}(C^x)$. \square

Definition 4. *For any graph G and any color $x \in \bar{L}$, we define the x -color subgraph G^x to be the induced subgraph of G defined by: $v \in V(G^x)$ if and only if $x \in L(v)$.*

Remark that if L^x denotes the list of the graph G^x defined by: $L^x(v) = \{x\}$ for any $v \in V(G^x)$, then C^x is an $(L^x, w(C^x))$ -coloring of G^x .

2.2. Hyperrectangles. In order to define the hyperrectangles, let us introduce a (partial) order in \mathbb{N}^n .

For any vectors $\vec{x}, \vec{y} \in \mathbb{N}^n$, we say that

$$\vec{y} = \sum_{i=1}^n y_i \vec{e}_i \leq \vec{x} = \sum_{i=1}^n x_i \vec{e}_i$$

if and only if $y_i \leq x_i$ for all $1 \leq i \leq n$.

For any vector $\vec{x} \in \mathbb{N}^n$, we define the hyperrectangle of \vec{x} (see Fig. 1) by:

$$R(\vec{x}) := \{\vec{y} \in \mathbb{N}^n \mid \vec{y} \leq \vec{x}\}.$$

For a finite set of vectors $X = \{\vec{x}_1, \dots, \vec{x}_k\}$ with $\vec{x}_i \in \mathbb{N}^n$, $1 \leq i \leq k$, we define the hyperrectangle of X , by:

$$R(X) = R(\{\vec{x}_1, \dots, \vec{x}_k\}) := \bigcup_{i=1}^k R(\vec{x}_i).$$

2.3. The set of maximal independent sets of a graph. Recall that an independent (or stable) set S of a graph G is a subset of $V(G)$ such that $vv' \notin E(G)$ for any $v, v' \in S$. A maximal independent set of a graph G is an independent set S of G of maximal cardinality, i.e. S is not the proper subset of another independent set.

Now, let G be a graph and L be a list of G . For any color x arising in L , we consider the maximal independent sets of the subgraphs G^x . They are subsets of $V(G)$ and we consider their associated vectors. Summing all these vectors, we obtain the following definition of the set $\vec{W}_{max}(G, L)$ which will be central in this paper.

For any sets X_1, \dots, X_k of vectors of \mathbb{R}^n , we recall that the vectorial sum is defined by:

$$\sum_{i=1}^k X_i := \{\vec{x}_1 + \dots + \vec{x}_k \mid \vec{x}_1 \in X_1, \dots, \vec{x}_k \in X_k\}.$$

Recall also that if N is a subset of $V(G) = \{v_1, \dots, v_n\}$, then the vector \vec{N} is defined by $\vec{N} = \sum_{i=1}^n \lambda_i \vec{e}_i$ with $\lambda_i = 1$ if $v_i \in N$ and 0 otherwise.

If $x \in \bar{L}$ and H is a subgraph of G we define:

$$\overrightarrow{MIS}(H) := \{\vec{N} \in \mathbb{N}^{|V(G)|} \mid N \text{ is a maximal independent set of } H\}.$$

Definition 5. For any graph G and any list L of G , we define

$$\vec{W}_{max}(G, L) := \sum_{x \in \bar{L}} \overrightarrow{MIS}(G^x).$$

3. THE SET OF ALL COLORINGS

For any graph G , any list L of G and any weight w of G , we consider the set $\mathcal{C}(G, L, w)$ of all (L, w) -colorings of G .

The purpose of this section is to give a description of this set. In order to do it, we define the maximal (L, w) -colorings set:

$$\mathcal{C}(G, L, w)_{max} := \{C \in \mathcal{C}(G, L, w) \mid \forall x \in \bar{L}, \vec{w}(C^x) \in \overrightarrow{MIS}(G^x)\}.$$

From Proposition 3, we have the following property:

$$\mathcal{C}(G, L, w)_{max} \neq \emptyset \iff \vec{w} \in \vec{W}_{max}(G, L). \quad (*)$$

For any $C \in \mathcal{C}(G, L, w)$ and any $\vec{d} \in \mathbb{N}^n$, we define the subcoloring set:

$$\mathcal{C}^-(C, \vec{d}) := \{C' \mid \forall v \in V(G) : C'(v) \subset C(v), \text{ and } \vec{w}(C') = \vec{w}(C) - \vec{d}\}.$$

Theorem 6. For any graph G , any list L of G and any permissible weight w of G i.e. such that G is (L, w) -colorable, we have:

$$\mathcal{C}(G, L, w) = \bigcup_{\substack{\vec{w}' \in \vec{W}_{max}(G, L) \\ \vec{w}' \geq \vec{w}}} \bigcup_{C' \in \mathcal{C}(G, L, w')_{max}} \mathcal{C}^-(C', \vec{w}' - \vec{w}).$$

Proof. Let G be a graph, L a list of G and w a permissible weight. If $C \in \mathcal{C}(G, L, w)$, then for any $x \in \bar{L}$, we define the subset N^x of $V(G)$ such that $\vec{N}^x = \vec{w}(C^x)$. Therefore N^x is an independent set of G^x , and there exists a maximal independent set S^x of G^x such that $N^x \subset S^x$. We construct a list C' of G such that for any $x \in \bar{L}$, $\vec{w}(C'^x) = \vec{S}^x$. By construction $\vec{w}' = \vec{w}(C') = \sum_{x \in \bar{L}} \vec{w}(C'^x) \in \vec{W}_{max}(G, L)$, then $C' \in \mathcal{C}(G, L, w')_{max}$. Since $N^x \subset S^x$, then $\vec{w} = \sum_{x \in \bar{L}} \vec{w}(C^x) \leq \sum_{x \in \bar{L}} \vec{w}(C'^x) = \vec{w}'$, and by construction $C \in \mathcal{C}^-(C', \vec{w}' - \vec{w})$. Hence we have the first inclusion.

If $\vec{w}' \in \vec{W}(G, L)$ such that $\vec{w}' \geq \vec{w}$, and $C' \in \mathcal{C}(G, L, w')_{max}$. For any $C'' \in \mathcal{C}^-(C', \vec{w}' - \vec{w})$, we have $\vec{w}(C'') = \vec{w}' - (\vec{w}' - \vec{w}) = \vec{w}$, therefore $C'' \in \mathcal{C}(G, L, w)$, and we have the reverse inclusion. \square

4. THE SET OF ALL WEIGHTS

Now, we can state the main result of the paper: the set $\vec{W}(G, L)$ of all possible weights vectors \vec{w} such that G is (L, w) -colorable is given by the hyperrectangle of the set $\vec{W}_{max}(G, L)$:

Theorem 7. *For any graph G and any list L of G :*

$$\vec{W}(G, L) = R(\vec{W}_{max}(G, L)).$$

In other words, the graph G is (L, w) -colorable if and only if the vector \vec{w} belongs to the hyperrectangle constructed on the maximal independent sets of the subgraphs G^x 's.

Proof. Let G be a graph and L be a list of G . If $\vec{w} \in \vec{W}(G, L)$ then $\mathcal{C}(G, L, w) \neq \emptyset$. By Theorem 6, there exists $\vec{w}' \in \vec{W}_{max}(G, L)$ such that $\vec{w}' \geq \vec{w}$. Then $\vec{W}(G, L) \subset R(\vec{W}_{max}(G, L))$.

If $\vec{0} \neq \vec{w} \in R(\vec{W}_{max}(G, L))$, by construction there exists $\vec{w}' \in \vec{W}_{max}(G, L)$ such that $\vec{w}' \geq \vec{w}$. By Theorem 6 and Property (*) we have $\mathcal{C}(G, L, w) \neq \emptyset$, therefore $\vec{w} \in \vec{W}(G, L)$, and since $\vec{0} \in \vec{W}(G, L)$ we have the reverse inclusion. \square

Theorem 7 can be written in a nice way in the particular case of a a -uniform list \mathcal{L}_a (i.e. $\mathcal{L}_a(v) = \{1, 2, \dots, a\}$ for any v).

Corollary 8. *Let G be a graph with m maximal independent sets S_1, \dots, S_m . Then, we have:*

$$\vec{W}(G, \mathcal{L}_a) = \left\{ \sum_{i=1}^m x_i \vec{S}_i, \text{ with } x_i \in \mathbb{N} \text{ and } \sum_{i=1}^m x_i \leq a \right\}.$$

Proof. By definition we have $\vec{W}_{max}(G, \mathcal{L}_a) = \sum_{x \in \bar{L}} \overrightarrow{MIS}(G^x)$. In the case of the a -uniform list \mathcal{L}_a , the subgraph G^x is equal to G for any color $x \in \bar{L}$ thus $\vec{W}_{max}(G, \mathcal{L}_a) = \sum_{i=1}^a \overrightarrow{MIS}(G)$. Since $\overrightarrow{MIS}(G) = \{\vec{S}_1, \dots, \vec{S}_m\}$, we obtain

$$\vec{W}_{max}(G, \mathcal{L}_a) = \left\{ \sum_{i=1}^m x_i \vec{S}_i, \text{ with } x_i \in \mathbb{N} \text{ and } \sum_{i=1}^m x_i = a \right\}.$$

Then Theorem 7 concludes the proof taking the hyperrectangle of $\vec{W}_{max}(G, \mathcal{L}_a)$. \square

5. THE STATIC CHANNEL ASSIGNMENT PROBLEM

Let G be a graph and w a weight of G . Then, the weighted chromatic number $\chi(G, w)$ of G associated to the weight w is defined to be the smallest integer a such that G is (\mathcal{L}_a, w) -colorable: it is the minimum number of colors for which there exists a proper weighted a -coloring (see [3] for a recent study of this number). In the particular case where the weight w is defined by $w(v) = 1$ for all vertex v of G (i.e. if the weight-vector $\vec{w} = (1, \dots, 1)$) then $\chi(G, w)$ is nothing but the chromatic number $\chi(G)$ of G .

The static channel assignment problem can then be viewed as follows: for a given graph G and a given weight w of G , find the weighted chromatic number $\chi(G, w)$ and furthermore find an $(\mathcal{L}_{\chi(G, w)}, w)$ -coloring of G .

Our strategy to solve the static assignment problem is the following one.

Firstly, we want to find the weighted chromatic number $\chi(G, w)$. We consider the list \mathcal{L}_1 of G and we compute

$$\vec{W}_{max}(G, \mathcal{L}_1) := \sum_{x \in \mathcal{L}_1} \overrightarrow{MIS}(G^x) = \overrightarrow{MIS}(G).$$

We check whether $\vec{w} \in R(\vec{W}_{max}(G, \mathcal{L}_1))$, i.e. if there exists $\vec{w}' \in \vec{W}_{max}(G, \mathcal{L}_1)$ such that $\vec{w} \leq \vec{w}'$.

If the answer is positive then we have $\chi(G, w) = 1$ by Theorem 7. Otherwise, we compute $\vec{W}_{max}(G, \mathcal{L}_2)$.

Remark 9. Note that, since $\chi(G, w) \geq \frac{\|\vec{w}\|}{\alpha(G)}$ where $\alpha(G)$ is the independence number of G i.e. the size of the largest independent set of G , we can begin with the computation of $\vec{W}_{max}(G, \mathcal{L}_{\frac{\|\vec{w}\|}{\alpha(G)}})$.

Note also that since our lists \mathcal{L}_a are a -uniform lists, we have by Corollary 8 an easy description of the set $\vec{W}_{max}(G, \mathcal{L}_a)$.

Hence we find $a = \chi(G, w)$ as soon as we find $\vec{w}' \in \vec{W}_{max}(G, \mathcal{L}_a)$ such that $\vec{w}' \geq \vec{w}$ and such that

$$\vec{w}' = \sum_{i=1}^a \vec{z}_i \in \sum_{i=1}^a \overrightarrow{MIS}(G).$$

By Theorem 6, we can construct an (\mathcal{L}_a, w') -coloring C' of G .

But we have by Proposition 3:

$$\tilde{C}' = \bigcup_{x=1}^a \tilde{C}'^x \quad \text{and} \quad \vec{w}'(C'^x) = \vec{z}_x.$$

By Theorem 6, it is sufficient to take one $C \in \mathcal{C}^-(C', \vec{w}' - \vec{w})$ to get a (\mathcal{L}_a, w) -coloring of G .

6. THE ON CALL PROBLEM

The *on call problem* can be modeled as follows : for $\vec{w} \notin \vec{W}(G, L)$, find $\vec{w}^* \in \vec{W}(G, L)$ such that $\vec{w}^* \leq \vec{w}$ and $\|\vec{w} - \vec{w}^*\|$ is minimal. We define the vector $\min(\vec{x}, \vec{y})$ as the vector \vec{z} such that $z_i = \min(x_i, y_i)$ for all $i \in \{1, \dots, n\}$. Now for a fixed vector \vec{w} we define the set

$$\min(\vec{w}, \vec{W}_{max}(G, L)) := \{\min(\vec{w}, \vec{w}') \mid \vec{w}' \in \vec{W}_{max}(G, L)\}.$$

Theorem 10. *Let G be a graph, L a list of G and w a weight of G . Then \vec{w}^* is a solution to the on call problem if and only if \vec{w}^* is a vector of $\min(\vec{w}, \vec{W}_{max}(G, L))$ of maximal norm i.e. $\vec{w}^* \in \min(\vec{w}, \vec{W}_{max}(G, L))$ such that $\forall \vec{w}' \in \min(\vec{w}, \vec{W}_{max}(G, L))$, we have $\|\vec{w}^*\| \geq \|\vec{w}'\|$.*

Proof. For any graph G , any list L of G , and any weight w of G , if \vec{w}^* is a solution to the on call problem, then $\vec{w}^* \in \vec{W}(G, L)$. By Theorem 7, there exists $\vec{w}' \in \vec{W}_{max}(G, L)$ such that $\vec{w}^* \leq \vec{w}'$. Since by definition, $\vec{w}^* \leq \vec{w}$, then $\vec{w}^* \leq \min(\vec{w}, \vec{w}') \leq \vec{w}$, and therefore $\|\vec{w} - \min(\vec{w}, \vec{w}')\| \leq \|\vec{w} - \vec{w}^*\|$.

By the minimality property, we have $\vec{w}^* = \min(\vec{w}, \vec{w}') \in \min(\vec{w}, \vec{W}_{max}(G, L))$. Moreover, for any $\vec{w}'' \in \min(\vec{w}, \vec{W}_{max}(G, L))$, since $\vec{w} \geq \vec{w}^*$ and $\vec{w} > \vec{w}''$, we have

$$\|\vec{w} - \vec{w}^*\| = \|\vec{w}\| - \|\vec{w}^*\| \leq \|\vec{w}\| - \|\vec{w}''\| = \|\vec{w} - \vec{w}''\|,$$

thus $\|\vec{w}^*\| \geq \|\vec{w}''\|$.

Let \vec{w}^* be a solution to the on call problem and let $\vec{w}^{**} \in \min(\vec{w}, \vec{W}_{max}(G, L))$ such that $\forall \vec{w}' \in \min(\vec{w}, \vec{W}_{max}(G, L))$, we have $\|\vec{w}^{**}\| \geq \|\vec{w}'\|$. We have $\vec{w}^{**} = \min(\vec{w}, \vec{u})$ with $\vec{u} \in \vec{W}_{max}(G, L)$, hence $\vec{w}^{**} \in R(\vec{W}_{max}(G, L))$ thus $\vec{w}^{**} \in \vec{W}(G, L)$ by Theorem 7.

By construction $\vec{w} \geq \vec{w}^{**} \in \vec{W}(G, L)$ such that $\|\vec{w} - \vec{w}^{**}\| = \|\vec{w} - \vec{w}^*\|$, therefore \vec{w}^{**} is also a solution to the on call problem. \square

7. NON-RECOLORING PROBLEM

Let G be a graph, w_0 a weight of G and $a_0 = \chi(G, w_0)$ the weighted chromatic number of G associated to w_0 . Now, consider the list \mathcal{L}_{a_0} of G and C_0 an (\mathcal{L}_{a_0}, w_0) -coloring of G . Finally let w be a weight of G such that $\vec{w} \geq \vec{w}_0$.

The non-recoloring problem is to find the smallest a (denoted by $\chi(G, w, C_0)$) such that there exists an (\mathcal{L}_a, w) -coloring C of G such that C_0 is a subcoloring of C . In other words

$$C_0 \in \mathcal{C}^-(C, \vec{w} - \vec{w}_0).$$

We define the set $\vec{W}_{max}(G, \mathcal{L}_{a_0}, C_0)$ to be the set of vectors $\vec{w}_1 \in \vec{W}_{max}(G, \mathcal{L}_{a_0})$ such that there exists an (\mathcal{L}_{a_0}, w_1) -coloring C_1 of G such that $C_0 \in \mathcal{C}^-(C_1, \vec{w}_1 - \vec{w}_0)$.

By definition we have $\vec{W}_{max}(G, \mathcal{L}_{a_0}, C_0) \subset \vec{W}_{max}(G, \mathcal{L}_{a_0})$

Then we set

$$\vec{\delta}(G, \mathcal{L}_{a_0}, C_0, w) := \{\vec{w} - \min(\vec{w}, \vec{w}_1) \mid \vec{w}_1 \in \vec{W}_{max}(G, \mathcal{L}_{a_0}, C_0)\}.$$

Theorem 11. *If G is a graph with the above notation then*

$$\chi(G, w, C_0) \leq a_0 + \min_{\vec{w}' \in \vec{\delta}(G, \mathcal{L}_{a_0}, C_0, w)} \chi(G, w').$$

Proof. Let $a = a_0 + \min_{\vec{w}' \in \vec{\delta}(G, \mathcal{L}_{a_0}, C_0, w)} \chi(G, w')$. Let $\vec{w}^* \in \vec{\delta}(G, \mathcal{L}_{a_0}, C_0, w)$ such that

$$\chi(G, w^*) = \min_{\vec{w}' \in \vec{\delta}(G, \mathcal{L}_{a_0}, C_0, w)} \chi(G, w').$$

Then there exists $\vec{w}^{**} \in \vec{W}_{max}(G, \mathcal{L}_{a_0}, C_0)$ such that

$$\vec{w}^* = \vec{w} - \min(\vec{w}, \vec{w}^{**}).$$

Since $\vec{w} \geq \vec{w}_0$ and by definition of \vec{w}^{**} , the vector $\vec{w}_3 := \min(\vec{w}, \vec{w}^{**}) \geq \vec{w}_0$, we can thus construct a (\mathcal{L}_{a_0}, w_3) -coloring C_3 of G such that $C_0 \in \mathcal{C}^-(C_3, \vec{w}_3 - \vec{w}_0)$. By our construction, choosing the colors in the set $[a_0+1, a]$, we can construct an $(\mathcal{L}_{a-a_0}, w^*)$ -coloring C_4 of G . Finally we construct C such that $\tilde{C} := \tilde{C}_3 \tilde{\cup} \tilde{C}_4$, thus C is an (\mathcal{L}_a, w) -coloring of G and thus $\chi(G, w, C_0) \leq a$. \square

We believe that the inequality in Theorem 11 can be replaced by an equality but we have not been able to prove it.

8. ALGORITHMIC CONSIDERATIONS

Proofs of Theorems 6, 7, 10 and 11 are all constructive and thus algorithms can be derived from them. But, of course, since the problems considered are all NP-complete, there is little hope for polynomial complexity.

By Theorem 7, the problem of knowing, for a given graph G with a list assignment L , if a given weight \vec{w} is permissible (i.e. if G is (L, w) -colorable) reduces to that of constructing the set $\vec{W}_{max}(G, L)$ (if the set is generated vector by vector, then we can stop as soon as a vector \vec{w}' with $w' \geq w$ is output).

```

Data: graph  $G$ ; list  $L$ ;
Result: the vector set  $\vec{W}_{max}(G, L)$ 
begin
  M  $\leftarrow$  MIS( $G$ );
  W  $\leftarrow$   $\{(0, 0, \dots, 0)\}$ ;
  for  $i \in \bar{L}$  do
    W  $\leftarrow$  VecSum( $W, M, i$ );
  return W;

Function VecSum( $S, S', c$ ) ; // computes the vectorial sum of  $S$ 
and the restriction of  $S'$  to  $G^c$ 
begin
  T  $\leftarrow$   $\emptyset$ ;
  for  $s \in S$  do
    for  $s' \in S'$  do
       $s'^c \leftarrow$  the restriction of  $s'$  to  $G^c$ ;
      if  $s'^c$  is maximal in  $G^c$  then
        T  $\leftarrow$  T  $\cup$   $\{s + s'^c\}$ ;
  return T;

```

Algorithm 1: computing $\vec{W}_{max}(G, L)$

For the problem of given a graph G of order n with a list L , listing the vector set $\vec{W}_{max}(G, L)$, a good measure of performance is the time required

compared with the size m of $\vec{W}_{max}(G, L)$. The set $\vec{MIS}(G)$ of all maximal independent vectors of G can be constructed in time within a polynomial factor of its size [9] (that can be as large as $n^{\frac{n}{3}} = (1.44225)^n$). Then, for any color x , the set $\vec{MIS}(G^x)$ can be computed 'on the fly' by checking if the restriction of each vector of $\vec{MIS}(G)$ to G^x is maximal (clearly, for any independent set of G , its restriction to G^x is also an independent set). Checking the maximality can be done in $O(n^2)$ operations. Algorithm 1 describes the steps to compute the set $\vec{W}_{max}(G, L)$. Its time complexity in the worst case is in $O(m^\ell)$, where $\ell = |\bar{L}|$.

REFERENCES

- [1] J. M. Byskov, *Algorithms for k -coloring and finding maximal independent sets*, In: Proc. 14th Symp. Discrete Algorithms, pp. 456-467, ACM and SIAM, 2003.
- [2] J. M. Byskov, *Enumerating maximal independent sets with applications to graph colouring*, Operations Research Letters 32 (6), pp. 547-556, 2004.
- [3] M. Caramia and J. Fiala, *New lower bounds on the weighted chromatic number of a graph*, Discussiones Mathematicae Graph Theory, 24 (2), (2004), 183-195.
- [4] M. Caramia and P. Dell'Olmo, *Solving the minimum weighted coloring problem*, Networks 38 (2), 88-101 (2001).
- [5] P. Erdős, A.L Rubin and H. Taylor, *Choosability in graphs*, Proc. West-Coast Conf. on Combinatorics, Graph Theory and Computing, Congressus Numerantium XXVI, (1979), 125-157.
- [6] W. K. Hale, *Frequency assignment: Theory and applications*, Proceedings of the IEEE, 68(12):1497-1514, (1980).
- [7] B. Jaumard, O. Marcotte, and C. Meyer, *Mathematical models and exact methods for channel assignment in cellular networks*, B. Sanso and P. Soriano, editors, Telecommunications Network Planning, Norwell, (1999).
- [8] I. Katzala and S. Naghsineh, *Channel assignment schemes for cellular mobile telecommunication systems: A comprehensive survey*, IEEE Personal Communications, 3, 3, 10-31, (1996).
- [9] S. Tsukiyama, M. Ide, H. Ariyoshi and I. Shirakawa, *A new algorithm for generating all the maximal independent sets*, SIAM J. Comput. 6(3), pp. 505-517, 1977.
- [10] V. G Vizing, *Coloring the vertices of a graph in prescribed colors (in Russian)*, Diskret. Analiz. No. 29, Metody Diskret. Anal. v Teorii Kodov i Shem 101 (1976), 3-10.

INSTITUT DE MATHÉMATIQUES DE TOULON AND INSTITUT DE MATHÉMATIQUES DE LUMINY, UNIVERSITÉ DU SUD TOULON-VAR, FRANCE, AND LABORATOIRE LE2I, UNIVERSITÉ DE BOURGOGNE, FRANCE

E-mail address: yves.aubry@univ-tln.fr, godinjeanchri@yahoo.fr and olivier.togni@u-bourgogne.fr