

Modeling Dengue Outbreaks

Marcelo J Otero, Daniel H Barmak, Claudio O Dorso, Hernán G Solari

Departamento de Física, FCEyN-UBA and IFIBA-CONICET

Mario A Natiello

Centre for Mathematical Sciences, Lund University, Sweden

Abstract

We introduce a dengue model (SEIR) where the human individuals are treated on an individual basis (IBM) while the mosquito population, produced by an independent model, is treated by compartments (SEI). We study the spread of epidemics by the sole action of the mosquito. Exponential, deterministic and experimental distributions for the (human) exposed period are considered in two weather scenarios, one corresponding to temperate climate and the other to tropical climate. Virus circulation, final epidemic size and duration of outbreaks are considered showing that the results present little sensitivity to the statistics followed by the exposed period provided the median of the distributions are in coincidence. Only the time between an introduced (imported) case and the appearance of the first symptomatic secondary case is sensitive to this distribution. We finally show that the IBM model introduced is precisely a realization of a compartmental model, and that at least in this case, the choice between compartmental models or IBM is only a matter of convenience.

Keywords: epidemiology, dengue, Individual Based Model, Compartmental Model, stochastic

1. Introduction

Dengue fever is a vector-borne disease produced by a *flavivirus* of the family *flaviviridae* [1]. The main vectors of dengue are *Aedes aegypti* and *Aedes albopictus*.

The research aimed at producing dengue models for public policy use began with Newton and Reiter [2] who introduced the minimal model for dengue in the form of a set of Ordinary Differential Equations (ODE) for the human population disaggregated in Susceptible, Exposed, Infected and Recovered compartments. The mosquito population was not modeled in this early work. A different starting point was taken by Focks et al. [3, 4] that began by describing mosquito populations in a computer framework named Dynamic Table Model where later the human population (as well as the disease) was introduced [5].

Newton and Reiter’s model (**NR**) favours economy of resources and mathematical accessibility, in contrast, Focks’ model emphasize realism. These models represent in Dengue two contrasting compromises in the standard trade-off in modeling. A third starting point has been recently added. Otero, Solari and Schweigmann (**OSS**) developed a dengue model [6] which includes the evolution of the mosquito population [7, 8] and is spatially explicit. This last model is somewhat in between Focks’ and NR as it is formulated as a state-dependent Poisson model with exponentially distributed times.

Each approach has been further developed [9, 10, 11, 12, 13, 14, 15]. ODE models have received most of the attention. Some of the works explore: variability of vector population [9], human population [10], the effects of hypothetical vertical transmission of Dengue in vectors [11], seasonality [12], age structure [13] as well as incomplete gamma distributions for the incubation and infectious times [16]. Contrasting modeling outcomes with those of real epidemics has shown the need to consider spatial heterogeneity as well [17].

The development of computing technology has made possible to produce Individual Based Models (**IBM**) for epidemics [18, 19]. IBM have been advocated as the most realistic models [19] since their great flexibility allows the modeler to describe disease evolution and human mobility at the individual level. When the results are only to be analysed numerically, IBM are probably the best choice. However, they are frequently presented in a most unfriendly way for mathematicians as they usually lack a formulation (expression in closed formulae) and are –at best– presented as algorithms if not just in words [18]. In contrast, working on the ODE side, it has been possible, for example, to achieve an understanding of the influence of distribution of the infectious period in epidemic modeling [20, 21, 22]. IBM have been used to study the time interval between primary and secondary cases [23] which is influenced, in the case of dengue, mainly by the extrinsic (mosquito) and intrinsic (human) incubation period.

In this work an IBM model for human population in a dengue epidemic is presented. The model is driven by mosquito populations modeled with spatial heterogeneity with the method introduced in [8] (see Section II). The IBM model is then used to examine the actual influence of the distribution of the incubation period comparing the most relevant information produced by dengue models: dependence of the probability of dengue circulation with respect to the mosquito population and the total epidemic size. Exponential, delta (fixed times, deterministic) and experimental [24] distributions are contrasted (Section III). The infectious period and the extrinsic incubation period is modeled using experimental data and measured transmission rates (human to mosquito) [24].

The IBM model produced is critically discussed. We show that it can be mapped exactly into a stochastic compartmental model of a novel form (see Section IV) thus crossing for the first time the valley separating IBM from compartmental models. This result opens new perspectives which we also discuss in Section IV. Finally, Section V presents the conclusions of this work.

2. The model

It is currently accepted that the dengue virus does not make any effect to the vector. As such, *Aedes aegypti* populations are independent of the presence of the virus. In the present model mosquito populations are produced by the *Aedes aegypti* model [8] with spatial resolution of one *block* using climatic data tuned to Buenos Aires, a temperate city where dengue circulated in the summer season 2008-2009 [25]. The urban unit of the city is the *block* (approximately a square of 100m x 100m). Because of the temperate climate the houses are not open as it is often the case in tropical areas. Mosquitoes usually develop in the center of the block which often presents vegetation and communicates the buildings within the block. The model then assumes that mosquitoes belong to the block and not to the houses and they blood-feed with equal probability in any human resident in the block. *Aedes aegypti* is assumed to disperse seeking for places to lay eggs. The mosquito population, number of bites per day, dispersal flights and adult mortality information per block is obtained from the mosquito model [8].

The time-step of the model has been fixed at one day. The human population of each block is fixed in the present work and the disease is spatially spread by the mosquito alone. The evolution of the disease in one individual human, h , proceeds as follows:

Day $d = d_0$ The virus is transmitted by the bite of an infected mosquito

Day $d = d_0 + \tau_E(h)$ The human h becomes infective (h is said to be exposed to the virus during this period of time).

Day $d = d_0 + \tau_E(h) + j$ For $1 \leq j \leq \tau_I$ the human h is infective and transmits the virus to a biting mosquito with a probability $p_{hm}(j)$. τ_I indicates the duration in days of the viremic window.

Day $d > d_0 + \tau_E(h) + \tau_I$ The human h is recovered and no longer transmits dengue.

The cycle in the human being is then of the form Susceptible, Exposed, Infected, Recovered (SEIR).

The virus enters the mosquito when it bites a viremic human with a probability $p_{hm}(j)$ depending of the day j in the infectious cycle of the specific human bitten. The cycle continues with the reproduction of the virus within the mosquito (extrinsic period), lasting τ_m days (in this work τ_m was set to 8 days). After this reproduction period the mosquito becomes infectious and transmits the virus with a probability p_mh when it bites. The mosquito follows a cycle Susceptible, Exposed, Infected (SEI) and does not recover. [1, 5, 24, 6]. The adult female mosquito population as produced by the *Aedes aegypti* simulation is then split into susceptible, τ_m stages of exposed and one infective compartment according to their interaction with the viremic human population and the number of days elapsed since acquiring the virus.

The epidemic starts when one or more humans become viremic. The algorithm followed is:

1. Give individual attributes, $\tau_E(h)$ according to prescribed distribution.
2. Read geometry, size of viremic window, probabilities $p_{mh}(j)$, $j = 1 \dots \tau_I$, human population in each block, day of the year when the epidemic starts.
3. Initialise the blocks with the human population.
4. Read total adult female mosquito population of the day (M), bites, flights to neighbouring blocks and mosquito death probability. Initialise all mosquitoes as susceptible (MS). Set infective bites to zero.
5. Day-loop begins:
 - (a) Calculate the amount of surviving infected mosquitoes. Compute surviving mosquito population with d exposed days, age them by one day. Exposed mosquitoes evolve to infected ones after $d = \tau_m$ days (Use binomial random number generator).
 - (b) Compute probability for a mosquito bite to transmit dengue as $p_{minf} = p_{mh}M_I/M$ (compound probability of being infective and being effective in the transmission). Each bite is an independent event according to the underlying mosquito model.
 - (c) Compute the probability for a bite to be made by a susceptible mosquito out of all the non-infective bites $p_{otras} = M_S/(M(1 - p_{minf}))$. The non-infective bites have probability $(1 - p_{minf})$, and come from infected mosquitoes failing to transmit the virus, exposed and susceptible mosquitoes, $M(1 - p_{minf}) = M - p_{mh}M_I = M_S + M_E + (1 - p_{mh})M_I$.
 - (d) Calculate the number of infected and susceptible mosquito bites using binomials with the previous probabilities and the number of total bites.
 - (e) Compute number of humans bitten in each day of the infected state, $H_I(j)$.
 - (f) Compute the number of new exposed mosquitoes, taking into account that the probability of human-mosquito contagion is dependent on the stage-day of the human infection. The amount of new infected insects is chosen using binomials. For this purpose, we add the results of the calculation of the number of susceptible mosquitoes that bite humans and get infected, $M_{NE} = \sum_{j=1}^{\tau_I} Bin(p_{hm}(j), H_I(j))$. Where M_{NE} are the new exposed mosquitoes, $Bin(H_I(j), p_{hm}(j))$ is a binomial realization with the day-dependent probability $p_{hm}(j)$ and $H_I(j)$ the quantity of infected humans bitten by susceptible mosquitoes on infection day j .
 - (g) Perform a random equi-distributed selection of humans bitten by infectious mosquitoes. Build a table of bitten individuals.
 - (h) Update the state of all the humans. If the human belongs to the Susceptible state and has been bitten according to the table built in (5g) then change the state of selected human to Exposed, record d_0 for each exposed human. Susceptible individuals not bitten by an infective mosquito will remain as such and consequently their intrinsic time d remains in 0. Increase the intrinsic time of Exposed

and Infected humans by one. Those Exposed individuals for which their intrinsic time has surpassed the value $d = d_0 + \tau_E(h)$ are moved to the Infected state, while those Infected individuals whose intrinsic time is larger than $d = d_0 + \tau_E(h) + \tau_I$, are moved to the Removed state

- i. Compute the number of individuals in each state for every cell.
 - ii. Read the total adult female mosquito population of the day (M), bites, flights to neighboring blocks.
6. Repeat all over again from (5a). Each iteration is a new day of the simulation.

3. Epidemic dependence on the distribution of the exposed period

We implemented four different distributions for the duration of the exposed period assigned to human individuals: Nishiura's experimental distribution ([24]), a delta and exponential distributions with the same mean than the experimental one and an exponential distribution with the same median than the experimental one. We call them N,D,E1 and E2 respectively.

The study was performed in two different climatic scenarios, one with constant temperature of 23 degrees Celsius, that represents tropical regions and one with the mean and amplitude characteristic of Buenos Aires, a city with temperate climate. The number of effective breeding sites [7] was varied between 50 and 1000.

The main questions were: considering the total number of recovered individuals, how is the distribution of epidemic sizes influenced by the choice of distribution? How does the probability for having no secondary cases change? How is the predicted duration of the epidemic influenced by our choices? And finally, how is the distribution of time between epidemiologically related cases affected?

Before showing our results, it is worth to realise that the probability of having no secondary cases will not be sensitive to the choice of distribution for the exposed period, as this probability depends only on the probability of the introduced case being bitten by the mosquitoes, the probability of the mosquitoes of acquiring the virus, surviving the extrinsic period and finally transmitting the virus to a human in a bite. Nothing in this process depends on the choice of distribution. In contrast, we expect the distribution of times between epidemiologically related cases to depend strongly on the choice of distribution, since it reflects the sum of the two incubation periods (intrinsic and extrinsic).

The simulations were performed using identical mosquito populations in all cases (same data file), for an homogeneous urban area of 20 by 20 blocks, hosting 100 people per block, making a total of 40000 human beings. Hence, all differences correspond to the disease dynamics that was previously identified as the main source of stochastic variations. The simulations with temperate climate were started on January 1st, i.e., ten days after the summer solstice

(December 21st in the southern hemisphere). The reported statistics is computed by averaging the outcomes of 1000 simulations with different seeds for the pseudo-random routines.

Confirming the reasoning above, there is no sensitivity for the probability of having local circulation of the virus (defined as having at least one secondary case following the introduced case) with the statistical distribution of the exposed period, see Figure 1.

The size of the epidemic at constant temperatures makes a transition from very small outbreaks to a large outbreak reaching almost all the people in the simulation. The transition happens in the region 50-100 breeding sites per block for the four distributions studied, see Figure 2. We detected no epidemiologically important differences produced by the use of one or another distribution function.

The size of epidemics with seasonal dependence is presented in Figure 3. The size of the epidemic outbreak begins to increase with the number of breeding sites in the 100-150 region for all the distributions, suggesting that R_0 (the basic reproductive number) is not affected by the statistic of exposed times (conceptually, R_0 is the average number of secondary cases produced by a single case when the epidemic starts). The results for the D-distributions and N-distribution do not present differences. The E1-distribution (equal mean) overestimates the final size while the E2-distribution substantially agrees with the N (experimental) one. Both exponential distributions present a larger variance than the N-distribution. This difference may matter when worst-possible scenarios are considered.

It is possible to argue that the differences in epidemic size observed for different distributions in the case with seasonal dependence correspond to a faster evolution of the epidemic outbreak during the time-window of favourable conditions. On the other hand, in the constant temperature scenario the epidemic outbreak stops because of the decrease in susceptible people produced by the epidemic. In this case we observe no significant differences, see Figure 4, the epidemic size always ends up around 40000 individuals. However, the epidemics evolves faster the larger the number of breeding sites (rightmost plots). It is worth observing that major outbreaks last more than one year in this 40000 people urbanization. Since there is no human movement incorporated, the duration of the outbreak depends critically on the dispersion of female mosquitoes.

At this point we could ask: is there any relevant statistics that depends on the distribution of exposed times? The answer is yes. Assume a case of imported dengue is detected, how long do we have to wait to know if we are facing an outbreak or not? The time elapsed between the primary and the first secondary case is given by adding the extrinsic incubation period and the exposed time. Box plots produced after 1000 simulations of outbreaks with a mosquito population supported on 200 BS per block are displayed in Figure 5. We observe that in this case the exponential distributions exaggerate the dispersion of results producing too early as well as too late cases as compared with the experimental distribution while the delta-distribution compresses the

“alert window” too much with respect to the experimental distribution.

4. Is the IBM model an implementation of a compartmental model?

The use of IBM in epidemiology is usually advocated on an ontological perspective [26, 19], we quote the argument in [19]

... the epidemiology literature has always described an infection history as a sequence of distinct periods, each of which begins and ends with a discrete event. The critical periods include the latent, the infectious, and the incubation periods. The critical events include the receipt of infection, the emission of infectious material, and the appearance of symptoms... Several implications can be drawn from these epidemiological principles and serve as a conceptual model for an individual infection process. First, it is most appropriate to represent the individual infection as a series of discrete events and periods. Second, the discrete events have no duration in their own right and only trigger the change between infection periods. Third, the discrete periods indicate the infection status of an individual and are part of the individual’s characteristics.

The evolution of dengue at the individual level is described in detail in the literature, including experimental results [24] which are seldom available for other illnesses. Thus, dengue is a good case to put the thesis at test.

The description in terms of events immediately calls for stochastic population models, while the different human to mosquito transmission probabilities can be handled easily introducing age structure in the infective human population, The description of the proper probability distribution for the exposed (latent) period is the major obstacle towards a compartmental stochastic model.

Each human individual spends k days, $k \in \{1 \dots \tau_E\}$, in the exposed state before becoming infective. The probability of any individual to spend k days is $P(k)$. Hence, in the group of N individuals that become infected at $d = d_0$, a portion $N(k)$ will spend k days before they become infective, where $N(k)$ is a random deviate taken from $Multinomial(N, P(1), \dots, P(\tau_E))$, a multinomial distribution. This is the only information available to the simulation. IBM generate additional structure, since each individual is assigned to one of the classes $N(1), \dots, N(\tau_E)$ in an entirely random way. This apparent additional information is in fact arbitrary because of the randomness and it is averaged out when presenting the results. Although the algorithm of the IBM model assigns the time spent in the exposed class to the individual, the final cause of having a distribution of exposed times is not known (neither to us nor to the algorithm). Different exposed times may arise either because of differences (in virus resistance) in the exposed individuals or because of differences in the incoming virus due e.g., to biological processes concerning the development and transmission of the virus by the mosquito.

Let us define

$$\hat{P}(k) = \sum_{j=k}^{\tau_E} P(j) \quad (1)$$

$$Q(k) = \frac{P(k)}{\hat{P}(k)} = P(j = k/j \geq k) \quad (2)$$

$$\hat{N}_k = N - \sum_{j=1}^k N(j) \quad (3)$$

Clearly $Q(k) \leq 1$ and $Q(\tau_E) = 1$. Consider the numbers $E(1) = N$, $E(k) = \text{Binomial}(E(k-1), 1 - Q(k))$ and $N(k) = E(k-1) - E(k)$ for $2 \leq k \leq \tau_E$.

We will now recall a few elementary results regarding multinomial distributions. We write *Multi* for the multinomial distribution

Lemma 1. (*Multinomial splitting*)

$$\begin{aligned} & \text{Multi}(N, p(1), \dots, p(k-1), p(k), \dots, p(\tau_E)) = \\ & = \text{Multi}(N, p(1), \dots, p(k-1), \hat{P}(k)) \text{Multi}(\hat{N}_k, Q(k), \dots, Q(\tau_E)) \end{aligned} \quad (4)$$

PROOF. The proof is simple algebra simplifying the expression for the probabilities in the right side of the equation.

Corollary 1. (*Binomial decomposition*) *The multinomial distribution can be fully decomposed in terms of binomial distributions in the form*

$$\text{Multi}(N, p(1), \dots, p(\tau_E)) = \prod_{k=1}^{\tau_E} \text{Binomial}(E(k), Q(k)) \quad (5)$$

PROOF. Repeated application of the previous lemma is all what is needed.

We now state the application of these results to our modeling problem.

Theorem 1. (*Compartmental presentation*) *Consider τ_E compartments associated to the days $k = 1, \dots, \tau_E$ after receiving the virus from the mosquito for those humans that are not yet infective. Let the population number in the k compartment be $E(k)$, and the number of humans that become infective on day k be $N(k)$ which is a random deviate distributed with $\text{Binomial}(E(k), Q(k))$, with the definitions given above. Then the exposed period that corresponds to the individuals is distributed with $P(k)$.*

PROOF. It follows immediately from the corollary.

5. Summary, discussion and conclusions

We have developed an IBM model for the evolution of dengue outbreaks that takes information from mosquito populations simulated with an *Aedes aegypti* model and builds thereafter the epidemic part of the evolution. The split between mosquito evolution and epidemic evolution is not perfect since the events *bite* and *flight* are treated as independent events while they are in fact correlated [27, 28, 29, 30], both being related to oviposition.

For mosquito populations sufficiently large to support the epidemic spread of dengue, most of the stochastic variability is provided by the epidemic process rather than by stochastic fluctuations in the mosquito population. Thus, the splitting of the models improves substantially the performance of the codes.

The model we developed is shown to be an IBM implementation of a compartmental model, of a form not usually considered. At the level of the description in this work, IBM does not play a fundamental role, contrary to what it has been previously argued [26, 19]. Rather, its use is a matter of algorithmic convenience. This result indicates that “IBM *versus* compartmental models” is not a fundamental dichotomy but it may be a matter of choice (depending of the skills and goals of the user): IBM facilitate coding, compartmental models lend themselves to richer forms of analysis.

The model was used to explore the actual influence of the distribution of exposed time for humans in those characteristics of epidemic outbreaks that matter the most: determining the level of mosquito abundance that makes unlikely the occurrence of a dengue outbreak and determining the size and time-lapse of the outbreak. The distributions used are (a) an experimentally obtained distribution (Nishiura [24]) (labeled N), (b) and (c) exponential distributions adjusted to have the same mean or the same median as N, labeled E1 and E2, and (d) a fixed time equal to the experimental mean (labeled the D-distribution). The probability of producing one or more secondary cases after the arrival of an infective human does not depend on the choice of distribution. The characteristic size of the epidemics under a temperate climate are exaggerated by the E1-distribution but presents no substantial difference for the other distributions. The dispersion of values is exaggerated by both exponential distributions. We observed no important differences in the duration of epidemics developed under a constant temperature since the outbreaks reach almost all the population and the velocity is regulated by the dispersion of the mosquitoes in the absence of movement by humans.

The only statistic able to discriminate easily between the four distributions of exposed time was found to be the time of appearance of the first secondary case. A result that was expected as well.

In conclusion, only very specific matters seem to depend on the characteristics of the distribution of exposed times for human beings. Looking towards the past, conclusions reached using exponential and delta distributions cannot be objected on such basis. Looking towards the future, simple compartmental models can be constructed as well using realistic distributions and there is no reason to limit the models to the choice: exponential, gamma or delta.

References

- [1] D. J. Gubler, Dengue and dengue hemorrhagic fever, *Clinical Microbiology Review* 11 (1998) 480–496.
- [2] E. A. C. Newton, P. Reiter, A model of the transmission of dengue fever with an evaluation of the impact of ultra-low volume (ulv) insecticide applications on dengue epidemics, *Am. J. Trop. Med. Hyg.* 47 (1992) 709–720.
- [3] D. A. Focks, D. C. Haile, E. Daniels, G. A. Moun, Dynamics life table model for *aedes aegypti*: Analysis of the literature and model development, *Journal of Medical Entomology* 30 (1993) 1003–1018.
- [4] D. A. Focks, D. C. Haile, E. Daniels, G. A. Mount, Dynamic life table model for *aedes aegypti*: Simulations results, *Journal of Medical Entomology* 30 (1993) 1019–1029.
- [5] D. A. Focks, D. C. Haile, E. Daniels, D. Keesling, A simulation model of the epidemiology of urban dengue fever: literature analysis, model development, preliminary validation and samples of simulation results, *Am. J. Trop. Med. Hyg.* 53 (1995) 489–505.
- [6] M. Otero, H. G. Solari, Mathematical model of dengue disease transmission by *aedes aegypti* mosquito, *Mathematical Biosciences* 223 (2010) 32–46.
- [7] M. Otero, H. G. Solari, N. Schweigmann, A stochastic population dynamic model for *aedes aegypti*: Formulation and application to a city with temperate climate, *Bull. Math. Biol.* 68 (2006) 1945–1974.
- [8] M. Otero, N. Schweigmann, H. G. Solari, A stochastic spatial dynamical model for *aedes aegypti*, *Bulletin of Mathematical Biology* 70 (2008) 1297–1325.
- [9] L. Esteva, C. Vargas, Analysis of a dengue disease transmission model, *Mathematical Biosciences* 150 (1998) 131–151.
- [10] L. Esteva, C. Vargas, A model for dengue disease with variable human population, *Journal of Mathematical Biology* 38 (1999) 220–240.
- [11] L. Esteva, C. Vargas, Influence of vertical and mechanical transmission on the dynamics of dengue disease, *Mathematical Biosciences* 167 (2000) 51–64.
- [12] L. M. Bartley, C. A. Donnelly, G. P. Garnett, The seasonal pattern of dengue in endemic areas: Mathematical models of mechanisms, *Transactions of the royal society of tropical medicine and hygiene* 96 (2002) 387–397.
- [13] P. Pongsumpun, I. M. Tang, Transmission of dengue hemorrhagic fever in an age structured population, *Mathematical and Computer Modelling* 37 (2003) 949–961.

- [14] K. Magori, M. Legros, M. E. Puente, D. A. Focks, T. W. Scott, A. L. Lloyd, F. Gould, Skeeter buster: A stochastic, spatially explicit modeling tool for studying *Aedes aegypti* population replacement and population suppression strategies, *PLoS Negl Trop Dis* 3 (9) (2009) e508.
- [15] M. L. Fernández, M. Otero, H. G. Solari, N. Schweigmann, Eco-epidemiological modelling of aedes aegypti transmitted diseases. case study: yellow fever in buenos aires 1870-1871, under review process. Preprint available from the authors (2010).
- [16] G. Chowella, P. Diaz-Dueñas, J. Miller, A. Alcazar-Velazco, J. Hyman, P. Fenimore, C. Castillo-Chavez, Estimation of the reproduction number of dengue fever from spatial epidemic, *Mathematical Biosciences* 208 (2007) 571–589.
- [17] C. Favier, D. Schmit, C. D. M. Müller-Graf, B. Cazelles, N. Degallier, B. Mondet, M. A. Dubois, Influence of spatial heterogeneity on an emerging infectious disease: The case of dengue epidemics, *Proceedings of the Royal Society (London): Biological Sciences* 272 (1568) (2005) 1171–1177.
- [18] V. Grimm, Ten years of individual-based modelling in ecology: what have we learned and what could we learn in the future?, *Ecological Modelling* 115 (2-3) (1999) 129 – 148.
- [19] L. Bian, A conceptual framework for an individual-based spatially explicit epidemiological model, *Environment and Planning B: Planning and Design* 31 (3) (2004) 381–385.
- [20] A. Lloyd, Destabilization of epidemic models with the inclusion of realistic distributions of infectious periods, *Proceedings Royal Society London B* 268 (2001) 985–993.
- [21] A. L. Lloyd, Realistic distributions of infectious periods in epidemic models: Changing patterns of persistence and dynamics, *Theoretical Population Biology* 60 (1) (2001) 59 – 71.
- [22] Z. Feng, D. Xu, H. Zhao, Epidemiological models with non-exponentially distributed disease stages and applications to disease control, *Bulletin of Mathematical Biology* 69 (2007) 1511–1536.
- [23] P. Fine, The interval between successive cases of an infectious disease, *American Journal of Epidemiology* 158 (11) (2003) 1039–1047.
- [24] H. Nishiura, S. B. Halstead, Natural history of dengue virus (denv)-1 and denv-4 infections: Reanalysis of classic studies, *Journal of Infectious Diseases* 195 (2007) 1007–1013.
- [25] A. Seijo, Y. Romer, M. Espinosa, J. Monroig, S. Giamperetti, D. Ameri, L. Antonelli, Brote de dengue autoctono en el area metropolitana buenos aires. experiencia del hospital de enfermedades infecciosas f. j. muñiz, *Medicina* 69 (2009) 593–600, iSSN 0025-7680.

- [26] J. S. Koopman, J. W. Lynch, Individual causal models and population system models in epidemiology, *American Journal of Public Health* 89 (8) (1999) 1170–1174.
- [27] M. Wolfensohn, R. Galun, A method for determining the flight range of *aedes aegypti* (linn.), *Bull. Res. Council of Israel* 2 (1953) 433–436.
- [28] P. Reiter, M. A. Amador, R. A. Anderson, G. G. Clark, Short report: dispersal of *aedes aegypti* in an urban area after blood feeding as demonstrated by rubidium-marked eggs., *Am. J. Trop. Med. Hyg* 52 (1995) 177–179.
- [29] L. E. Muir, B. H. Kay, *Aedes aegypti* survival and dispersal estimated by mark-release-recapture in northern australia., *Am. J. Trop. Med. Hyg.* 58 (1998) 277–282.
- [30] J. D. Edman, T. W. Scott, A. Costero, A. C. Morrison, L. C. Harrington, G. G. Clark, *Aedes aegypti* (diptera culicidae) movement influenced by availability of oviposition sites., *J. Med. Entomol.* 35 (4) (1998) 578–583.

List of Figures

1	Probability of local circulation of virus (probability of having at least one secondary case). Top: with a tropical temperature scenario. Bottom: with a tempered climate.	14
2	Box plot graphs for the epidemic size (total number of infected humans) at constant temperature. Top-left: N-distribution, top-right: E1-distribution, bottom-left D-distribution and bottom-right: E2-distribution.	15
3	Box plot graphs for the epidemic size with seasonal dependence. Top-left, N-distribution, top-right, E1-distribution, bottom-left D-distribution and bottom-right, E2-distribution. In x-axis number of breeding sites, BS, per block.	16
4	Statistics for the duration (in days) of the epidemic outbreak at constant temperature for different number of breeding sites, left to right 50, 100, 150 and 200 BS per block. Top line, N-statistics, second line E1-statistics, third line E2-statistics and bottom line D-statistics.	17
5	Distribution of times between the arrival of an infectious person and the time for the first secondary case. The scenario corresponds to 200BS/block at constant temperature of 23°C and 100 people per block. Results correspond to the delta-distribution (D), the experimental distribution (N), the exponential E2 and E1 distributions.	18
6	Scheme for the progression of dengue. Circles for human subpopulations (Susceptible, Exposed by day, Infective by day and Recovered) and squares for mosquito subpopulations. Solid directed arrows indicate daily progression, dotted directed arrows indicate several days of progression, bi-directed arrows with a circle indicate interactions resulting in transitions for members of one population. Probabilities are indicated next to arrows. The mosquito dynamics (birth, death, . . .) is not represented. . .	18

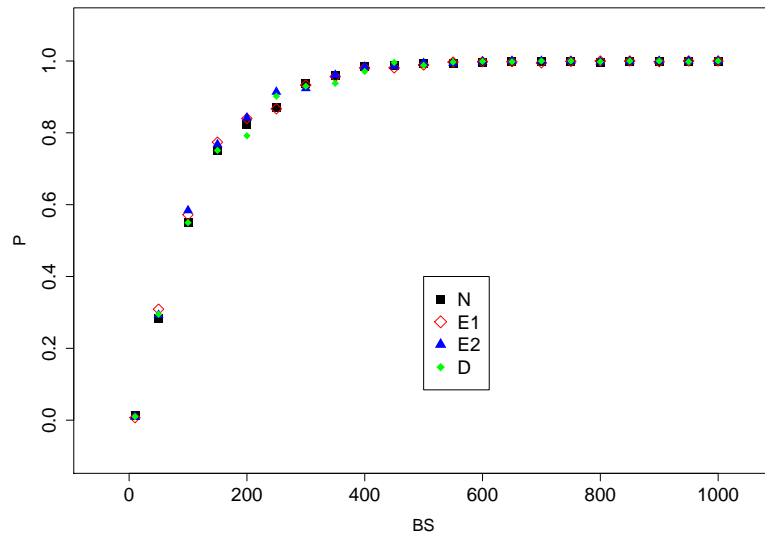
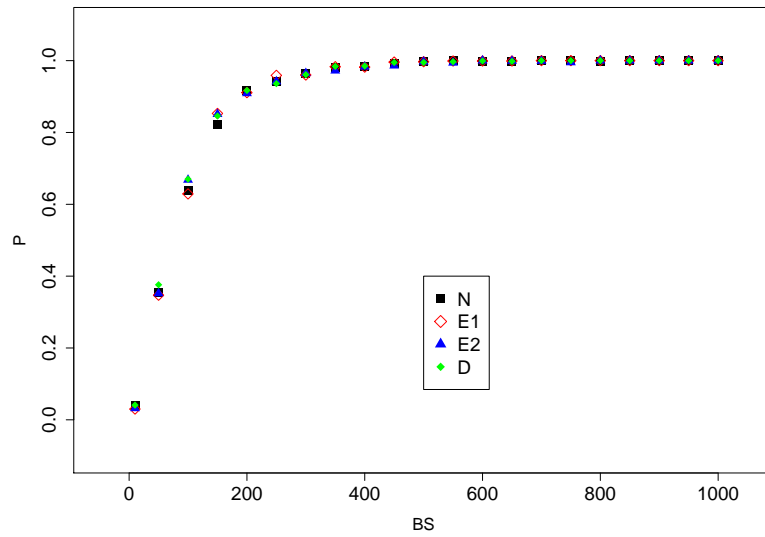

Figure 1: Probability of local circulation of virus (probability of having at least one secondary case). Top: with a tropical temperature scenario. Bottom: with a tempered climate.

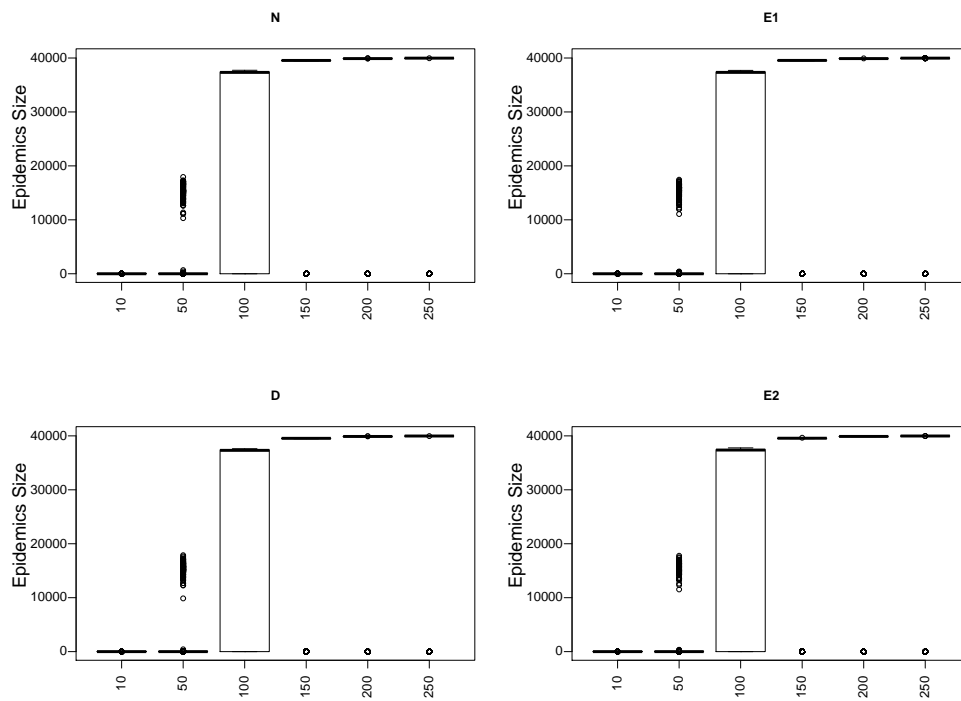

Figure 2: Box plot graphs for the epidemic size (total number of infected humans) at constant temperature. Top-left: N-distribution, top-right: E1-distribution, bottom-left D-distribution and bottom-right: E2-distribution.

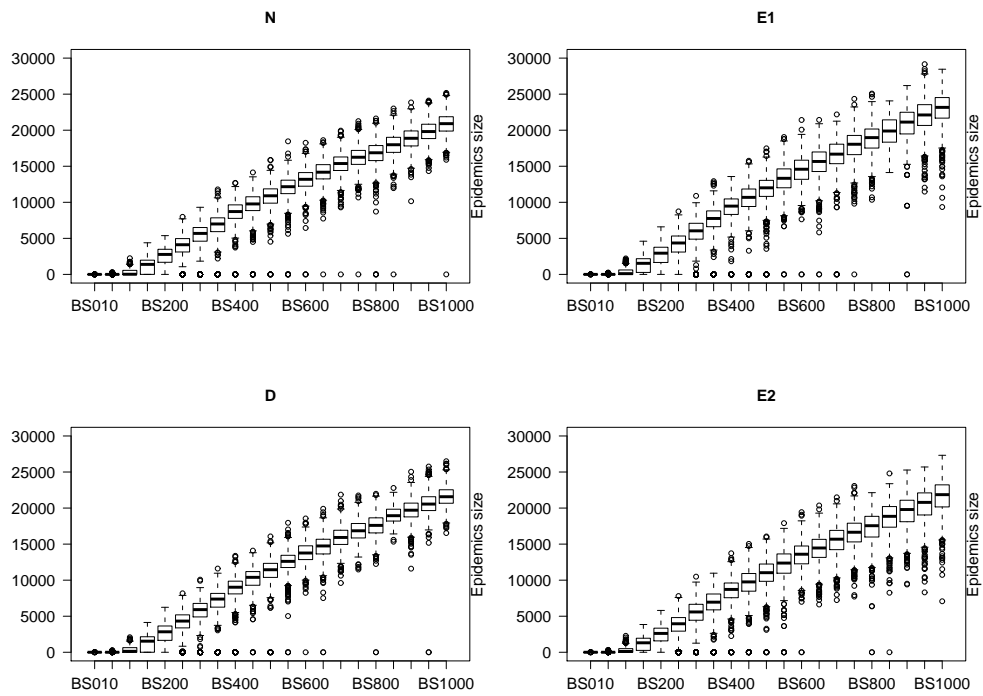

Figure 3: Box plot graphs for the epidemic size with seasonal dependence. Top-left, N-distribution, top-right, E1-distribution, bottom-left D-distribution and bottom-right, E2-distribution. In x-axis number of breeding sites, BS, per block.

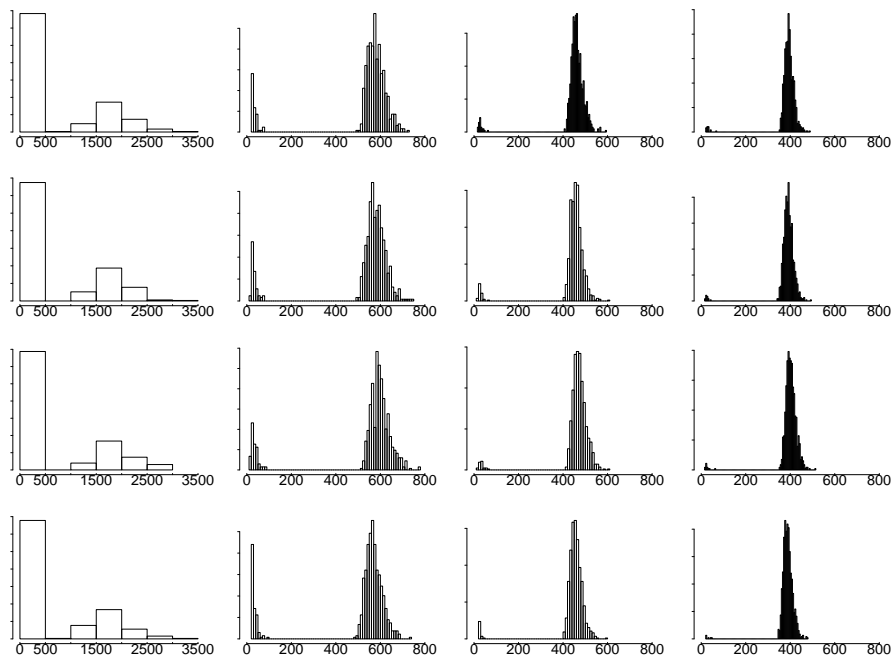

Figure 4: Statistics for the duration (in days) of the epidemic outbreak at constant temperature for different number of breeding sites, left to right 50, 100, 150 and 200 BS per block. Top line, N-statistics, second line E1-statistics, third line E2-statistics and bottom line D-statistics.

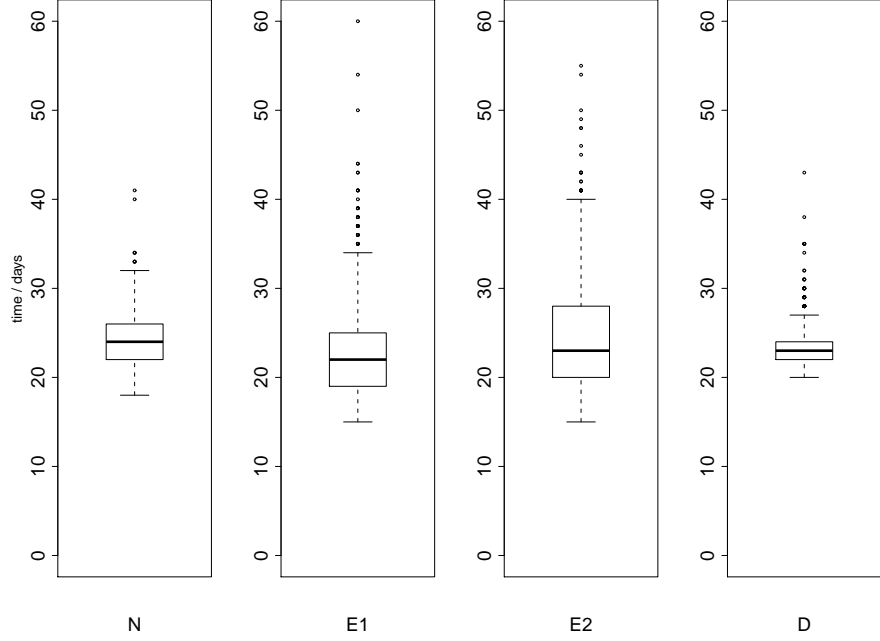

Figure 5: Distribution of times between the arrival of an infectious person and the time for the first secondary case. The scenario corresponds to 200BS/block at constant temperature of 23°C and 100 people per block. Results correspond to the delta-distribution (D), the experimental distribution (N), the exponential E2 and E1 distributions.

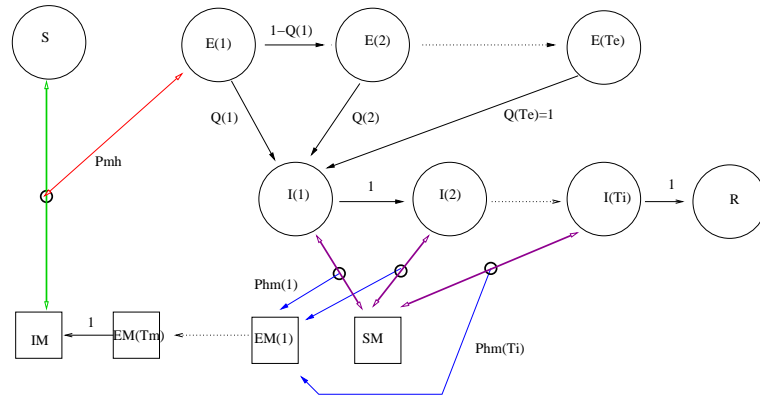

Figure 6: Scheme for the progression of dengue. Circles for human subpopulations (Susceptible, Exposed by day, Infective by day and Recovered) and squares for mosquito subpopulations. Solid directed arrows indicate daily progression, dotted directed arrows indicate several days of progression, bi-directed arrows with a circle indicate interactions resulting in transitions for members of one population. Probabilities are indicated next to arrows. The mosquito dynamics (birth, death, ...) is not represented.