

# Experimental quantum key distribution based on a Bell test

Alexander Ling<sup>1,2</sup>, Matthew P. Peloso<sup>1</sup>, Ivan Marcikic, Valerio Scarani<sup>1,3</sup>, Antía Lamas-Linares<sup>1,3</sup>, and Christian Kurtsiefer<sup>1,3</sup>

<sup>1</sup> *Department of Physics, National University of Singapore, Singapore 117542*

<sup>2</sup> *Temasek Laboratories, National University of Singapore, Singapore 123456*

<sup>3</sup> *Centre for Quantum Technologies, National University of Singapore, Singapore 117543*

(Dated: March 3, 2019)

We report on a complete free-space field implementation of a modified Ekert91 protocol for quantum key distribution using entangled photon pairs. For each photon pair we perform a random choice between key generation and a Bell inequality. The amount of violation is used to determine the possible knowledge of an eavesdropper to ensure security of the distributed final key.

*Introduction.* Proposals for quantum key distribution (QKD) were first published over two decades ago [1, 2, 3]. In particular, the protocol of Bennett and Brassard in 1984 (BB84) sought to distribute a random encryption key via correlated polarization states of single photons [1, 3]. Its strength was derived from the no-cloning theorem [4, 5] which stated that the state of a single quantum system cannot be copied perfectly. A measurement attempt on the distributed key is revealed as errors in the expected correlation of the measurement results. BB84 must treat all noise as evidence of an eavesdropper. Whether a completely secure key can then be distilled after error correction [6] depends only on the fraction of errors in the initial key.

The ‘quantum’ nature of QKD was explored from a different angle in 1991 when Ekert proposed an implementation using non-local correlations between maximally entangled photon-pairs [7]. The quality of entanglement between a photon-pair can be measured by the degree of violation of a Bell inequality [8]. Maximally entangled photon-pairs have perfect correlations in their polarization states, and violate the Clauser-Horne-Shimony-Holt (CHSH) version [9] of this inequality with the maximum value. The defining feature in Ekert91 is the suggestion to use the degree of violation of the CHSH inequality as a test of security. This conjecture is related to the concept later known as the monogamy of entanglement [10]: the entanglement between two systems decreases when a third system (for example, the measurement apparatus of an eavesdropper) interacts with the pair.

Although BB84 and Ekert91 utilize different aspects of quantum mechanics, once one writes down explicitly the expected qubit states and the measurements that should be performed, the two protocols turn out to generate the same set of correlations [11]. When these calculations were extended to include error correction and privacy amplification, a quantitative link was found between Eve’s information (assuming individual attacks) and the amount of violation of the CHSH inequality [12], thus vindicating Ekert’s intuition. BB84 and Ekert91 came to be considered as fully equivalent. In this perspective, the choice between a prepare-and-measure and an

entanglement-based implementation is dictated only by a balance of practical benefits. For instance, BB84 involves an active choice when encoding the logical bits 0 and 1 into the polarization states, requiring a trusted high-bandwidth random number source [13]; in comparison, no active choice is necessary with entanglement-based QKD. Besides its ability to remove the need for random number generators [14], technical difficulties related to the lack of practical true single photon sources can be avoided. The price of entanglement-based QKD is a lower key generation rate due to the limited brightness of contemporary entangled photon-pair sources when compared with faint coherent pulse approximations of single photon sources.

Recently two theoretical developments pointed to the fact that BB84 and Ekert91 may not be equivalent after all. The first such development are the proofs of unconditional security developed by Koashi and Preskill [15] and improved by Ma, Fung and Lo [16]. These authors proved that the security of entanglement-based implementations can be based on the sole knowledge of the error rate, because this quantity already contains information about the imperfection of the source — while such imperfections (in particular the photon-number statistics) must be carefully taken into account in BB84 [17, 18, 19]. The second development is due to Acín and coworkers [20]. These authors went back to Ekert’s original idea of basing the security *only* on the measured violation  $S$  of CHSH and derived the formula

$$I_{Eve} = h\left(\frac{1 + \sqrt{S^2/4 - 1}}{2}\right), \quad (1)$$

with the binary entropy  $h(x) = -x \log_2(x) - (1-x) \log_2(1-x)$ . This formula provides an unconditional security bound under the usual assumptions; it also guarantees partial security in a more paranoid scenario, in which the QKD devices are untrusted (we shall come back to this issue in the conclusions).

In this paper, we describe an entanglement-based QKD experiment in which we monitor the violation of the CHSH inequality and use (1) to quantify the degree of raw key compression in the privacy amplification step.

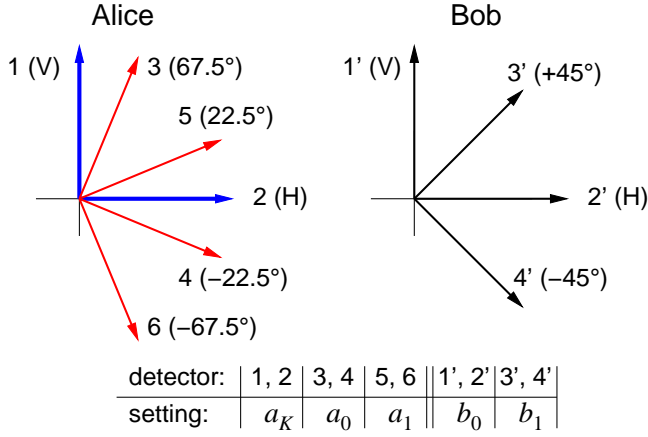

FIG. 1: Orientation of different detector polarizations. Coincidences (1,1') and (2,2') are used for key generation, while coincidences between any of (3,4,5,6) and any of (1',2',3',4') will be used for testing a CHSH inequality for various settings.

This is the first time when the security of QKD is based on the violation of a Bell-type inequality: in one of the first experiments [21], a Bell-type inequality was monitored, but no quantitative measure of security was derived from the observed violation; typically, implementations of entanglement-based QKD systems do not monitor Bell inequalities [14, 22, 23].

*Experiment.* We implement a modified Ekert91 protocol [24] that uses a minimal combination of three detection settings  $a_0, a_1, a_K$  on one side, and two distinct detection settings  $b_0, b_1$  on the other side for performing polarization measurements on a photon-pair in a singlet state  $|\Psi^-\rangle = \frac{1}{\sqrt{2}}(|H_A V_B\rangle - |V_A H_B\rangle)$ . The setting pair  $(a_K, b_0)$  in our experiment corresponds to horizontal/vertical polarization, and should lead (in the absence of noise) to a perfectly anti-correlated measurement result. These results will be used to produce the raw key. The setting  $b_0$  and the other ones are used to check the CHSH inequality  $|S| \leq 2$  in the form

$$S = E(a_0, b_0) + E(a_0, b_1) + E(a_1, b_0) - E(a_1, b_1). \quad (2)$$

The correlation coefficients  $E$  are determined from the number  $n_{ij}$  of coincidence events between detectors  $i$  on one side and  $j$  on the other side, collected during a given integration time  $T$ . Measurement bases are chosen such that a maximal violation of (2) with  $|S| = 2\sqrt{2}$  could be expected. Therefore, basis  $b_1$  has to be chosen to correspond to  $\pm 45^\circ$  linear polarization, and bases  $b, c$  need to form an orthogonal set corresponding to  $\pm 22.5^\circ, \pm 67.5^\circ$  linear polarizations (see Fig. 1). With that, we evaluate for example

$$E(a_0, b_0) = \frac{n_{3,1'} + n_{4,2'} - n_{3,2'} - n_{4,1'}}{n_{3,1'} + n_{4,2'} + n_{3,2'} + n_{4,1'}}, \quad (3)$$

and the other coefficients in (2) accordingly from an en-

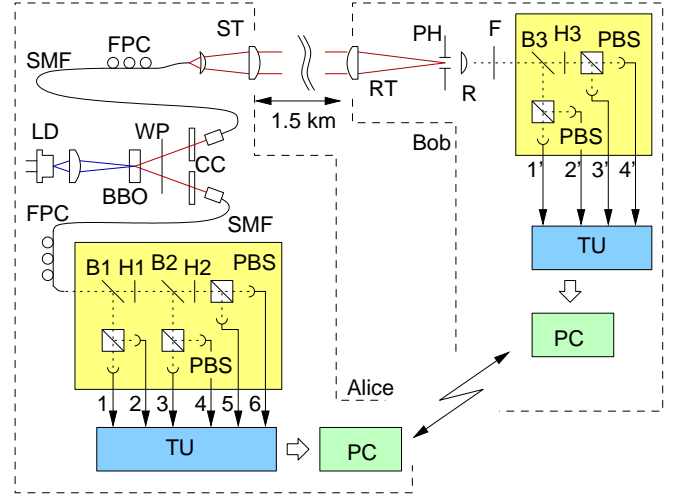

FIG. 2: Experimental setup. Polarization-entangled photon-pairs are generated via parametric down conversion pumped by a laser diode (LD) in a nonlinear optical crystal (BBO) with walk-off compensation (WP, CC) into single mode optical fibers (SMF). A free-space optical channel for one detector set (Bob) is realized using small telescopes on both sides (ST, RT) with some spatial and spectral filtering (PH, F). Both parties perform polarization measurements in bases randomly chosen by beam splitters (B1-B3), and defined by properly oriented wave plates (H1-H3) in front of polarizing beam splitters (PBS) and photon counting detectors. Photo events are registered separately with time stamp units (TU) connected to two PC linked via a classical channel.

semble of pair detection events.

The random choice of measurement bases is performed with a combination of polarization-independent beam splitters (B1-B3, see Fig. 2), with a 50:50 splitting ratio. This avoids an explicit generation of a random number by a device. The base settings corresponding to the angles shown in Fig. 1 are adjusted by appropriately oriented half wave plates (H1-H3).

The remaining elements of the experimental setup are similar to a previous experiment implementing an entanglement-based BB84 protocol [14]. Polarization-entangled photon-pairs are generated in a compact diode-laser pumped non-collinear type-II parametric down conversion process [25] with efficient collection techniques into single mode optical fibers [26, 27]. We pump a 2 mm thick  $\beta$ -Barium Borate (BBO) crystal at a wavelength of 407 nm with a power of 40 mW and observe a photo coincidence rate of about  $18000\text{s}^{-1}$  in passively-quenched silicon avalanche photodiodes directly at the source. We separate the two measurement devices by approx. 1.5 km in an urban environment, introducing a link loss of about 3 dB caused primarily by atmospheric absorption at the down converted wavelength of 810 nm and fluctuations in the transmission due to scintillation.

Background light suppression (at night) was accom-

plished using a spatial filter (PH) in the receiving telescope with an acceptance range of  $\Omega = 6.5 \cdot 10^{-9}$  sr and a color glass filter (RG780) with a peak transmission of  $\approx 90\%$  for the down-converted light at 810 nm.

Correlated photons are identified by recording their time of arrival at each detector and running a cross correlation of the timing information on both sides (similar to the scheme in [14]). The virtual coincidence window defined in software was 3.75 ns, and we monitored the accidental coincidences in an equally wide time window offset by 20 ns. Detector time delay compensation was adjusted to better than 0.5 ns to avoid leakage through a classical timing channel [28].

The experimental results from one 9.5 hour run are shown in Fig. 3. In this interval, we observe a small drop of the coincidence rate due to an alignment drift in the optical link. Accidental coincidences were about 1% of the coincidences from down-converted photon pairs.

Half of the identified photon pairs were seen by detectors (3,4,5,6) paired with (1',2',3',4'), which were used to evaluate the violation of (2). About a quarter of the pairs in detector combinations (1,2) with (1',2') contributed to the raw key, while the residual quarter of pairs in combinations (1,2) with (3',4') were discarded. Detectors (1,2,1',2') were adjusted to coincide with the natural axes of the downconversion crystal to keep the error rate on the raw key as small as possible.

Error correction following a modified CASCADE protocol was performed in real time on packets of least 10000 raw bits, which allowed us to arrive at a targeted final bit error ratio (BER) of  $10^{-12}$ . The corresponding quantum bit error ratio (QBER) was extracted out of this procedure (Fig. 3b). The combined correlation value  $S$  was extracted via (3) for the same time window. The value of  $S$  stayed at around 2.5 over the whole integration time (Fig. 3c). This is not a particularly high value, and we suspect a broad optical spectrum in the blue pump diode as a reason for this problem. This is compatible with lower polarization correlation in the  $\pm 45^\circ$  basis due to a residual distinguishability between the two decay paths in the SPDC process. However, it serves as a typical model for an eavesdropping attempt e.g. by a partial intercept-resend attack in the H/V basis. While such an attack is not revealed in the QBER in this protocol, it clearly shows in a reduction of  $S$  from the maximally expected value of  $2\sqrt{2}$ .

The average information leakage  $l$  per raw bit to an eavesdropper was estimated for each block following (1). Together with the revealed bits in the error correction procedure (and not assuming that any errors are due to intrinsic detector noise), we can then establish the private key fraction Alice and Bob can extract out of the privacy amplification hashing procedure from a given raw key block. The result over time is shown in Fig. 3d, resulting in an average final key rate of around  $300 \text{ bit s}^{-1}$  or about  $10^7$  bit of error-free secret key.

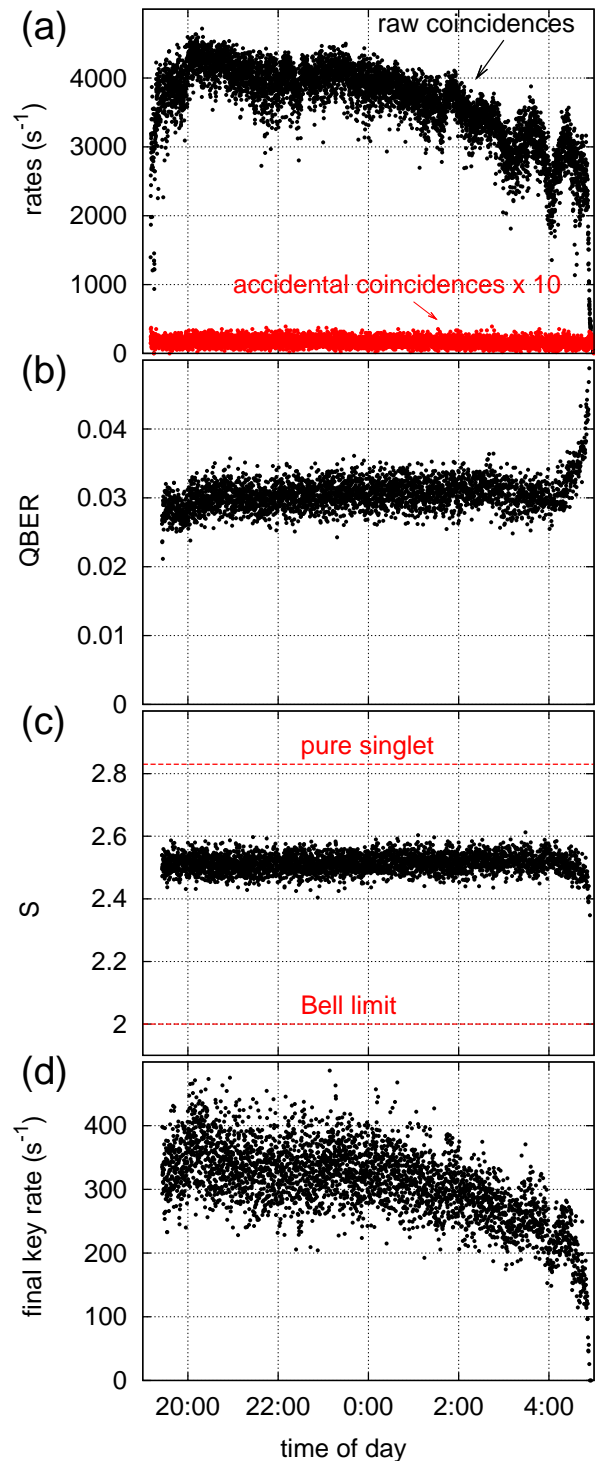

FIG. 3: Experimental results in a key distribution experiment implementing an Ekert91 protocol. (a) shows total (upper trace) and accidental (lower trace) detected coincidence rates between Alice and Bob, (b) the error ratio in the raw key, (c) the degree of violation of a CHSH-type Bell inequality, (d) the final key rate after error correction and privacy amplification. The experiment was terminated by a storm misaligning a telescope of the optical link at 5 am.

The estimation of the eavesdropper knowledge is applicable strictly only for an infinitely large number of bits; recent work on the security of finite length keys suggests that the privacy amplification should be carried out over large ensembles [29, 30, 31]. Using the finite-key bound of Ref. [32], we still would be able to extract a secret key of length around  $1.8 \times 10^6$  bit from the whole ensemble of error-corrected raw keys in this experimental run.

*Conclusion and perspectives.* We have demonstrated a free space implementation of an Ekert91 protocol. The security of the key distilled was derived from the violation of the CHSH inequality. This ensured that the key was distributed not by some arbitrary random number generator, but with the non-local correlations shared by entangled photon-pairs. This is interesting because it is now possible to consider scenarios where the protocol might be useful when BB84 is no longer secure. One can imagine a situation where the photon-pair source is controlled by an untrusted third-party, and still have secure key distribution. Equivalently, we need not ensure the exact size of the Hilbert space anymore, as deviations from the design would be captured by a non-maximal violation of the Bell inequality.

Using Ekert91 the communicating parties can give up control over the photon source. Is it possible that they can relinquish control over other apparatus? This was suggested by Acín et al. as a type of ‘device-independent’ QKD [20]. In their proposal, they used only the necessary assumptions in QKD and showed that the CHSH violation was sufficient to decide the security (against collective attacks) of a distributed key, even if the measurement apparatus was not trusted. Unfortunately, such a scheme is not yet experimentally feasible because of the stringent requirement it places on detector efficiencies [20, 33].

While our experiment seems otherwise close to an implementation of their suggestion, a subtle point of concern would be also the random choice of the subensembles chosen for key generation and Bell violation: the protocol requires a choice completely out of control of the eavesdropper, but our implementation leaves this decision to the beam splitter B1 in Fig. 2. Although one could construct an attack strategy of the eavesdropper on that beam splitter choice, it is not clear if such a vulnerability poses a weaker constraint than the assumption that an eavesdropper has no influence of the random choice of the authorized partners, or ultimately on their free will.

### Acknowledgment

This work was supported by the National Research Foundation and the Ministry of Education, Singapore.

- 
- [1] C. Bennett and G. Brassard, in *Proceedings of IEEE International Conference on Computers, Systems and Signal Processing, Bangalore, India, December 1984*, pp. 175 - 179. (1984).
  - [2] S. Wiesner, *Sigact News* **15**, 78 (1983).
  - [3] C. H. Bennett, F. Bessette, G. Brassard, L. Salvail, and J. Smolin, *J. Cryptology* **5**, 3 (1992).
  - [4] W. K. Wootters and W. H. Zurek, *Nature* **299**, 802 (1982).
  - [5] D. Dieks, *Phys. Lett. A* **92**, 271 (1982).
  - [6] C. Bennett, G. Brassard, and C. Crepeau, and U. Maurer, *Information Theory, IEEE Transactions on* **41**, 1915 (1995), ISSN 0018-9448.
  - [7] A. K. Ekert, *Phys. Rev. Lett.* **67**, 661 (1991).
  - [8] J. S. Bell, *Rev. Mod. Phys.* **38**, 447 (1966).
  - [9] J. F. Clauser, M. A. Horne, A. Shimony, and R. A. Holt, *Phys. Rev. Lett.* **23**, 880 (1969).
  - [10] V. Coffman, J. Kundu, and W. K. Wootters, *Phys. Rev. A* **61**, 052306 (2000).
  - [11] C. H. Bennett, G. Brassard, and N. D. Mermin, *Phys. Rev. Lett.* **68**, 557 (1992).
  - [12] C. A. Fuchs, N. Gisin, R. B. Griffiths, C.-S. Niu, and A. Peres, *Phys. Rev. A* **56**, 1163 (1997).
  - [13] J. Bienfang, A. Gross, A. Mink, B. Hershman, A. Nakassis, X. Tang, R. Lu, D. Su, C. Clark, C. Williams, et al., *Opt. Express* **12**, 2011 (2004).
  - [14] I. Marckic, A. Lamas-Linares, and C. Kurtsiefer, *Appl. Phys. Lett.* **89**, 101122 (2006).
  - [15] Koashi, M., and J. Preskill, *Phys. Rev. Lett.* **90**, 057902 (2003).
  - [16] Ma, X., C.-H. F. Fung, and H.-K. Lo, *Phys. Rev. A* **76**, 012307 (2007).
  - [17] Brassard, G., N. Lütkenhaus, T. Mor, and B. C. Sanders, 2000, *Phys. Rev. Lett.* **85**, 1330.
  - [18] Hwang, W.-Y., 2003, *Phys. Rev. Lett.* **91**, 057901.
  - [19] Scarani, V., A. Acín, G. Ribordy, and N. Gisin, 2004, *Phys. Rev. Lett.* **92**, 057901.
  - [20] A. Acín, N. Brunner, N. Gisin, S. Massar, S. Pironio, and V. Scarani, *Phys. Rev. Lett.* **98**, 230501 (2007).
  - [21] T. Jennewein, C. Simon, G. Weihs, H. Weinfurter, and A. Zeilinger, *Phys. Rev. Lett.* **84**, 4729 (2000).
  - [22] Naik, D.S., C.G. Peterson, A.G. White, A.J. Berglund, P.G. Kwiat, 2000, *Phys. Rev. Lett.* **84**, 4733.
  - [23] Tittel, W., J. Brendel, H. Zbinden, and N. Gisin, *Phys. Rev. Lett.* **84**, 4737 (2000).
  - [24] A. Acín, S. Massar, S. Pironio, *New J. Phys.* **8**, 126 (2006)
  - [25] P. G. Kwiat, K. Mattle, H. Weinfurter, A. Zeilinger, A. V. Sergienko, and Y. Shih, *Phys. Rev. Lett.* **75**, 4337 (1995).
  - [26] C. Kurtsiefer, M. Oberparleiter, H. Weinfurter, C. Kurtsiefer, M. Oberparleiter, and H. Weinfurter, *Phys. Rev. A* **64**, 023802 (2001).
  - [27] P. Trojek, C. Schmid, M. Bourennane, H. Weinfurter, and C. Kurtsiefer, *Opt. Express* **12**, 276 (2004).
  - [28] A. Lamas-Linares and C. Kurtsiefer, *Opt. Express* **15**, 9388 (2007).
  - [29] X.Ma, B. Qi, Y. Zhao, H.-K. Lo, *Phys. Rev. A* **72**, 012326 (2005); X.-B. Wang, *Phys. Rev. Lett.* **94**, 230503 (2005).
  - [30] J. Hasegawa, M. Hayashi, T.Hiroshima, A. Tanaka, A. Tomita, arXiv:0705.3081.
  - [31] V. Scarani, R.Renner, *Phys. Rev. Lett. in press* (2008)
  - [32] V. Scarani, R. Renner, in preparation

[33] Y. Zhao, C.-H. F. Fung, B. Qi, C. Chen, H.-K. Lo, [arXiv:0704.3253](#)