

Security proof for QKD systems with threshold detectors

Toyohiro Tsurumaru

*Mitsubishi Electric Corporation, Information Technology R&D Center,
5-1-1 Ofuna, Kamakura-shi, Kanagawa, 247-8501, Japan*

Kiyoshi Tamaki

*NTT Basic Research Laboratories, NTT Corporation,
3-1, Morinosato Wakamiya Atsugi-Shi,
Kanagawa, 243-0198, Japan
CREST, JST Agency, 4-1-8 Honcho,
Kawaguchi, Saitama, 332-0012, Japan*

In this paper, we rigorously prove the intuition that in security proofs for BB84 one may regard an incoming signal to Bob as a qubit state. From this result, it follows that all security proofs for BB84 based on a virtual qubit entanglement distillation protocol, which was originally proposed by Lo and Chau [H.-K. Lo and H. F. Chau, *Science* 283, 2050 (1999)], and Shor and Preskill [P. W. Shor and J. Preskill, *Phys. Rev. Lett.* 85, 441 (2000)], are all valid even if Bob's actual apparatus cannot distill a qubit state explicitly. As a consequence, especially, the well-known result that a higher bit error rate of 20% can be tolerated for BB84 protocol by using two-way classical communications is still valid even when Bob uses threshold detectors. Using the same technique, we also prove the security of Bennett-Brassard-Mermin 1992 (BBM92) protocol where Alice and Bob both use threshold detectors.

I. INTRODUCTION

Quantum key distribution (QKD) is a way to share a secret key between separated parties (Alice and Bob) with negligibly small leakage of its information to an unauthorized third party, Eve. The first QKD protocol, BB84, was introduced by Bennett and Brassard in 1984 [1], and its unconditional security was first proven by Mayers [2] in a bit complicated manner. After the first proof, researchers have tried to prove its security in a simple manner. Some proofs are based on entanglement distillation protocol (EDP) idea [3, 4, 5, 6], and others rely on uncertainty principle [2, 7] or information-theoretic approach [8].

In EDP-based security proofs, we usually assume implicitly that Bob has a detector which can discriminate between vacuum, single-photon, and multi-photon states in order to distill a qubit state, while this is not the case for the security proof based on uncertainty principle [7], i.e., the conventional on-off detectors (threshold detectors) can be used in this case. On the other hand, EDP-based security proof can apply to many protocols, including BB84 with two-way classical communications [5], with decoy states [9], for B92 [10], and so on [11], however the security proof based on uncertainty principle cannot directly apply to those protocols. Thus, it is important to consider from experimental or theoretical viewpoints how to accommodate the use of threshold detectors in EDP-based security proof, or to consider how to apply the uncertainty principle idea to the other protocols.

In this paper, we first prove unconditional security of BB84 with threshold detectors based on the argument of virtual EDP, which is valid regardless of one-way or two-

way classical communications. In order to show its security, instead of assuming photon-number discriminating detectors, we use a symmetry argument and introduce an explicit *squash operator* in the virtual protocol, which transforms Bob's incoming multi-photon state to a qubit state. Then we suppose that they run a virtual EDP on the obtained qubit pairs in order to extract secret keys.

If one-way classical communications are used in this setup, the secret key rate R from the single photon part is $R = 1 - H_2(e_{\text{bit}}^{\text{vi}}) - H_2(e_{\text{ph}}^{\text{vi}})$, where $e_{\text{bit}}^{\text{vi}}$ and $e_{\text{ph}}^{\text{vi}}$ are the phase and the bit error rates in the virtual protocol. As we shall show, these error rates are in fact equal to the bit error rate $e_{\text{bit}}^{\text{ac}}$ measured in the actual protocol. This means that all the formulas for key generation rate given in the preceding literatures of EDP-based security proofs are valid with threshold detectors, even when multi-photon emission is taken into account [6] or with decoy states [12]. Our formulation also applies to the case of two-way classical communications [5], hence the bit error rate threshold of 20% or higher is true with threshold detectors as well.

By using the same technique, we also prove the security of Bennett-Brassard-Mermin 1992 (BBM92) protocol [13], where Alice and Bob both use threshold detectors (see Fig.2). In BBM92 protocol, a third party supplies entangled states to Alice and Bob, and they measure it with the same set of bases as in BB84. If both the receivers have photon-number discriminating detectors and can reject incoming multi-photon states, this protocol is theoretically equivalent to BB84. When threshold detectors are used, however, the security of this protocol is not as straightforward, and we will give the security proof for this scheme in this paper.

The assumptions that we make for theoretical descrip-

tion of BB84 are as follows. First, it is assumed that Alice's signals are block diagonalized with respect to photon number, and thus one can treat events having different photon numbers as distinct classical events. Moreover, we assume that Alice's mixed states in z -basis and the one in x -basis are the same, i.e., there is no basis information flow from Alice's source.

We also suppose that when Alice emits a multi-photon state, all information regarding that bit is freely leaked to Eve due to the photon-number splitting attack [14]. It is proven, however, that we can still generate a secret key as long as Alice's signals contain a sufficiently high ratio of single-photon states [6]. This ratio can be well-monitored by the decoy state method [9, 12], resulting in longer distances of communications. Thus, only single-photon emission part is important, to which we restrict our attention in this paper.

Another assumption we make is that all imperfections of Alice's and Bob's devices, i.e., non-unit quantum efficiency of Bob's detectors, dark counts, miss-alignment, etc., are under Eve's control. This is the so-called *untrusted device scenario*, and with this hypothesis we are in a situation where Alice's and Bob's devices are all perfect. In addition, we suppose that Bob's phase modulator acts on multi-photon states as linear operations on tensor product states. In other words, they transform each photon contained in a signal independently, whether they are in a superposition or not (for more details, see Sec. II A).

Finally, when Bob's two detectors click simultaneously (coincidence count), he assigns a random bit to the corresponding event.

These assumptions are also made in our security proof of BBM92 except that Alice, as well as Bob, plays the role of a receiver. That is, imperfections of apparatuses are attributed to Eve's attack, and Alice's and Bob's phase modulators transform their incoming multi-photon states as tensor products. If a coincident-detection event occurs on either Alice's or Bob's side, he or she manually replaces it by a random bit.

This paper is organized as follows. We describe and formulate our model for actual QKD systems based on BB84 in Sec. II, and convert it into a virtual EDP in Sec. III. Subsequently in Sec. IV, we show that the phase and the bit error rates in the virtual protocol are equal to the bit error rate in the actual protocol. Sec. V is devoted to the security proof for BBM92. Then finally we conclude in Sec. VI.

II. DESCRIPTION OF OUR MODEL

In this section we illustrate our setup (Fig.1). As in usual implementations of BB84 protocol, Alice emits out signal pulses whose phases are chosen randomly out of $\{0, \pi, \pi/2, 3\pi/2\}$. Among them we regard a set of phase choices $\{0, \pi\}$ (respectively, $\{\pi/2, 3\pi/2\}$) as the encodings of bit value $b \in \{0, 1\}$ in z -basis (respectively, in

x -basis). After traveling Eve's regime, the signal pulse is again phase-modulated according to Bob's random basis choice, and then enters the detection unit consisting of a 50:50 beam splitter followed by two threshold detectors (Det Z_{th}), which read out the bit value b . Even when coincident detections occur on both detectors, Bob does not discard the event and instead assigns a random value for the output b . We denote the bit error rate observed in this protocol by e_{bit}^{ac} .

As mentioned in Introduction, the goal of this paper is to rigorously prove the security of QKD even when the receiver (or the receivers) uses threshold detectors which cannot distinguish photon numbers. Hence throughout the paper, we will always take into account the possibility that states which a receiver obtains contain more than one photon. To this end, we will below formulate general N -photon states and describe how they are transformed by Bob's phase modulations.

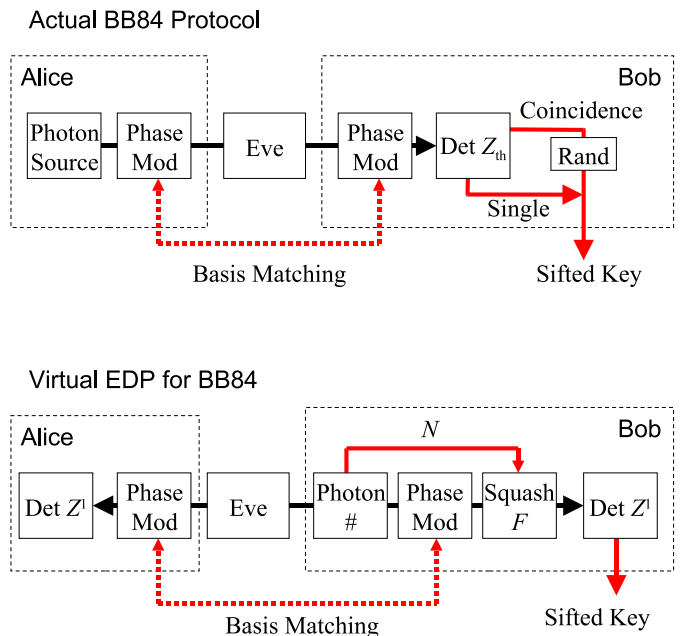

FIG. 1: Schematics of the actual BB84 protocol and the corresponding virtual EDP. Det Z_{th} in the actual protocol denotes Bob's threshold detectors. When two detectors click simultaneously (coincidence count), Bob assigns a random bit (Rand) to the corresponding event. In the virtual protocol Bob's states are projected to a two-dimensional vector space \mathcal{H}_D , and by identifying this as a qubit, Alice and Bob perform a virtual EDP.

A. Symmetry under particle permutations and the formulation of Bob's quantum operations

Consisting of identical particles with bosonic statistics, a state received by Bob is always symmetric under particle permutations [15] [16]. Hence an N -particle states

in Bob's Hilbert space \mathcal{H}_B can be expanded with basis

$$|S_{N-b,b}^z\rangle := \frac{1}{\sqrt{N!(N-b)!b!}} (|0_z^{N-b}1_z^b\rangle + \text{permutations}),$$

where $|0_z^{N-b}1_z^b\rangle = |0_z \cdots 0_z 1_z \cdots 1_z\rangle = |0_z\rangle \otimes \cdots \otimes |0_z\rangle \otimes |1_z\rangle \otimes \cdots \otimes |1_z\rangle$, with 0_z and 1_z repeating $N-b$ and b times respectively. $|S_{N-b,b}^y\rangle_B$ are defined in the y basis similarly (we define y basis and x basis as $|i_y\rangle \equiv (|0_z\rangle + (-1)^j |1_z\rangle)/\sqrt{2}$ ($j = 0, 1$) and $|i_x\rangle \equiv (|0_z\rangle + (-1)^j |1_z\rangle)/\sqrt{2}$, respectively). Thus for example, $|S_{0,2}^z\rangle = |0_z 0_z\rangle$, whereas $|S_{1,1}^z\rangle = \frac{1}{\sqrt{2}}(|0_z 1_z\rangle + |0_z 1_z\rangle)$ and $|S_{1,2}^y\rangle = \frac{1}{\sqrt{3}}(|0_y 1_y 1_y\rangle + |1_y 0_y 1_y\rangle + |1_y 1_y 0_y\rangle)$.

Using this basis, quantum non-demolition (QND) measurement of N -photon, to be mentioned below, can be represented by Kraus operators $E^N = \sum_{b=0}^N P(|S_{N-b,b}^z\rangle_B)$, where $P(|\psi\rangle) := |\psi\rangle\langle\psi|$.

As is usually the case for a linear operator on tensor product states, or as one typically encounters when adding angular momenta [15], Bob's phase modulator acts on these symmetric states independently in a qubit by qubit manner. For example, bit flip X operates on $|S_{3,0}^z\rangle$ as $X|0_z\rangle \otimes X|0_z\rangle \otimes X|0_z\rangle =: X^{\otimes 3}|S_{3,0}^z\rangle =: D(X)|S_{3,0}^z\rangle$, and similarly the Hadamard gate transforms $|S_{1,1}^z\rangle$ as $D(H)|S_{1,1}^z\rangle = \frac{1}{\sqrt{2}}(H|0_z\rangle \otimes H|1_z\rangle + H|1_z\rangle \otimes H|0_z\rangle)$, where

$$H := \frac{1}{\sqrt{2}} \begin{pmatrix} 1 & -1 \\ 1 & 1 \end{pmatrix}$$

in z -basis. If one regards qubit operations as rotations of spin-1/2, these symmetric N -photon states correspond to a spin- $N/2$ representation.

Photon detection in general corresponds to a projective measurement with respect to photon-number states in z -basis $\{|S_{N,0}^z\rangle, |S_{N-1,1}^z\rangle, \dots, |S_{0,N}^z\rangle\}$. Since Bob's threshold detectors cannot discriminate photon numbers in our case, it is assumed that they can only distinguish between vacuum $|S_{0,0}^z\rangle$, single detection events $|S_{N,0}^z\rangle, |S_{0,N}^z\rangle$, and coincident detection events $\{|S_{N-1,1}^z\rangle, \dots, |S_{1,N-1}^z\rangle\}$.

III. VIRTUAL PROTOCOL

In this section, in order to prove the security of our QKD, we convert the actual protocol to an equivalent virtual entanglement-based protocol. The argument proceeds in exactly the same manner as in Shor-Preskill [4] or in GLLP [6], except for the explicit construction of a *squash operator* F on Bob's side that projects an N -particle state received from Eve into a qubit state.

First, on Alice's side we assume that, instead of randomly choosing the phase of signal states out of $\{0, \pi/2, \pi, 3\pi/4\}$, Alice takes the following procedure; she prepares one of the Bell states

$$|\Phi^+\rangle_{AE} := \frac{1}{\sqrt{2}} (|0_z\rangle_A |0_z\rangle_E + |1_z\rangle_A |1_z\rangle_E),$$

keeps the first half in \mathcal{H}_A (reference state), and sends the second half in \mathcal{H}_E (signal state) to Eve. The converted protocol is still equivalent to the original since at any stage of it, she can effectively emit a random bit $b \in \{0, 1\}$ by measuring the reference state with z and x bases.

On receiving the signal pulse, Eve generates an arbitrary state in Bob's Hilbert state \mathcal{H}_B , which in general may be a superposition of any photon number N . As a result of this, Alice and Bob end up sharing an entangled state $\rho_{AB} \in \mathcal{H}_A \otimes \mathcal{H}_B$. Now, without sacrificing security, we may simplify the analysis further by assuming that ρ_{AB} is actually given from Eve to Alice and Bob. This state ρ_{AB} is subsequently phase modulated by Alice's and Bob's apparatuses, and becomes averaged into a symmetrized state ρ_{sym} due to basis matching (for more details, see Sec. IV A).

Then on Bob's side, we assume that immediately after receiving a pulse, he performs a QND measurement on the photon number N , described by Kraus operators $\{E^N\}_{N \in \mathbb{N}}$. For the sake of simplicity, we fix the value of N from now on, and sometimes suppress its indices. Following this measurement, Bob projects his state to a qubit state using a *squash operator* F which converts a state in his $N+1$ -dimensional Hilbert space \mathcal{H}_B to that in a qubit space \mathcal{H}_D . This consists of Kraus operators

$$F_{b,b'} := 2^{-(N-1)/2} \times \left\{ \sqrt{\binom{N}{b'}} |1_y\rangle\langle S_{N-b,b}^y| + \sqrt{\binom{N}{b}} |0_y\rangle\langle S_{N-b',b'}^y| \right\}, \quad (1)$$

for all combinations of $0 \leq b, b' \leq N$ satisfying $b - b' \equiv 1 \pmod{4}$. With these operators, ρ_{sym} symmetrized by phase modulations is converted to

$$\rho_F := F(\rho_{\text{sym}}) = \sum_{b,b'} F_{b,b'} \rho_{\text{sym}} F_{b,b'}^\dagger$$

in $\mathcal{H}_A \otimes \mathcal{H}_D$. In Appendix A, we prove that these operators indeed satisfy $\sum_{b,b'} F_{b,b'}^\dagger F_{b,b'} = \mathbb{I}_B$, and thus form a legitimate quantum operation.

As we shall show in the next section, if Alice and Bob both measure $F(\rho_{\text{sym}})$ in z -basis, their bit error rate $e_{\text{bit}}^{\text{vi}}$ exactly equals that in the original protocol $e_{\text{bit}}^{\text{ac}}$. In this respect, our virtual protocol can indeed be regarded as equivalent to the original one.

Then following the standard Shor-Preskill type argument [4, 6], we suppose that, instead of immediately conducting z -basis measurements, they run a virtual EDP in order to extract secret keys. That is, the goal of their EDP is to distill $|\Phi^+\rangle$ so that by measuring them in z -basis, they share secret keys. In order to ensure the success of EDP, we need to guarantee that both the bit error rate $e_{\text{bit}}^{\text{vi}}$ and the phase error rate $e_{\text{ph}}^{\text{vi}}$ are sufficiently small in our virtual protocol.

As we will prove in the next section, in fact they are both equal to the bit error rate $e_{\text{bit}}^{\text{ac}}$ measured in the actual protocol, i.e., $e_{\text{bit}}^{\text{vi}} = e_{\text{ph}}^{\text{vi}} = e_{\text{bit}}^{\text{ac}}$. Thus monitoring the

bit error rate in the actual protocol is equivalent to monitoring both the bit and the phase error rates in the virtual protocol. This means that all the previous security proofs for BB84 based on a virtual EDP [4, 5, 6, 9] are valid with threshold detectors, even when they involve two-way classical communications [5] or decoy states [9]. We note that the squash operation introduced in this paper is different from the one in GLLP in the following sense. In GLLP, the squash operation is preceded by phase modulations, while the phase modulations is preceded by the squash operation in our case.

IV. ESTIMATION OF ERROR RATES

In this section we show that for an arbitrary symmetric state ρ_{sym}

$$e_{\text{bit}}^{\text{vi}}(\rho_{\text{sym}}) = e_{\text{ph}}^{\text{vi}}(\rho_{\text{sym}}) = e_{\text{bit}}^{\text{ac}}(\rho_{\text{sym}}). \quad (2)$$

That is, the bit and the phase error rates in the virtual protocol is equal to the bit error rate in the actual one. We prove this in two steps; First by taking advantage of symmetry we decompose ρ_{sym} as a mixture of states $\sigma(a, b; a', b')$, to be defined below, and then show that Eq. (2) holds for any of these σ 's.

A. Symmetry under phase modulations

The symmetry transformations of BB84 protocol form a group G of order 16 generated by the Hadamard transformation H and bit flip X . An element g of group G acts on a state ρ_{AB} sent from Eve as

$$\begin{aligned} \rho_{AB} &\rightarrow [D_A(g) \otimes D_B(g)] \rho_{AB} [D_A(g) \otimes D_B(g)]^\dagger. \\ &=: D_{AB}(g) \rho_{AB} D_{AB}^\dagger(g). \end{aligned}$$

Here $D_A(g)$ denotes the usual operation on a qubit, e.g., $D_A(H) = H$ and $D_A(X) = X$, whereas $D_B(g)$ corresponds to $N/2$ -spin representation as mentioned in the previous subsection. As a result of basis matching by Alice and Bob, ρ_{AB} is averaged to

$$\rho_{\text{sym}} := \frac{1}{|G|} \sum_{g \in G} D_{AB}(g) \rho_{AB} D_{AB}^\dagger(g),$$

which is symmetric under phase modulations, i.e.,

$$D_{AB}(g) \rho_{\text{sym}} D_{AB}^\dagger(g) = \rho_{\text{sym}} \quad \text{for } \forall g \in G. \quad (3)$$

In order to see explicitly how the form of ρ_{sym} is restricted by symmetry, working in y basis is convenient. As a basis for the composite state of Alice's and Bob's, choose

$$|T_{a,b}\rangle_{AB} := |a_y\rangle_A |S_{N-b,b}^y\rangle_B \quad (4)$$

for $a \in \{0, 1\}$, and $b \in \{0, \dots, N\}$. Then using this basis, expand ρ_{sym} as

$$\rho_{\text{sym}} = \sum_{a,b} \sum_{a',b'} C(a, b; a', b') |T_{a,b}\rangle_{AB} \langle T_{a',b'}|,$$

where

$$C(a, b; a', b') = C^*(a', b'; a, b) \quad (5)$$

from the Hermiticity.

The Hadamard transformation H acts on these states as $D_{AB}(H)|T_{a,b}\rangle = \omega^{-\alpha(a,b)}|T_{a,b}\rangle$ with $\omega := e^{i\pi/4} = (1 + i)/\sqrt{2}$ and

$$\alpha(a, b) := 2(a + b) - N - 1.$$

From these relations and Eq. (3), we have

$$C(a, b; a', b') = 0 \quad \text{if } \alpha(a, b) - \alpha(a', b') \not\equiv 0 \pmod{8}. \quad (6)$$

Similarly, bit flip X , which acts as $D_{AB}(X)|T_{a,b}\rangle = i^{-\alpha(a,b)}|T_{1-a, N-b}\rangle$, yields

$$\begin{aligned} C(a, b; a', b') &= i^{\alpha(a,b) - \alpha(a', b')} \times \\ &C(1 - a, N - b; 1 - a', N - b'). \end{aligned} \quad (7)$$

From (5), (6) and (7), it follows that the symmetric state ρ_{sym} can be rewritten in a restricted form as

$$\rho_{\text{sym}} = \frac{1}{4} \sum_{a,b,a',b'} C(a, b; a', b') \sigma(a, b; a', b') + \text{H.c.}, \quad (8)$$

where the sum is over all combinations of a, b, a', b' satisfying $\alpha(a, b) - \alpha(a', b') \equiv 0 \pmod{8}$. ‘‘H.c.’’ stands for Hermitian conjugate. The state $\sigma(a, b; a', b')$ appearing in (8) is defined as

$$\sigma(a, b; a', b') := |T_{a,b}\rangle \langle T_{a',b'}| + |T_{1-a, N-b}\rangle \langle T_{1-a', N-b'}| \quad (9)$$

with arguments satisfying

$$\alpha(a, b) - \alpha(a', b') \equiv 0 \pmod{8}. \quad (10)$$

Hence without loss of generality, we may restrict ourselves to considering error rates $e_{\text{bit}}^{\text{ac}}(\sigma)$, $e_{\text{bit}}^{\text{vi}}(\sigma)$ and $e_{\text{ph}}^{\text{vi}}(\sigma)$ induced by $\sigma(a, b; a', b')$ with Eq. (10).

B. Comparison of error rates in the actual and the original protocols

Next we show that $e_{\text{bit}}^{\text{ac}}(\sigma) = e_{\text{bit}}^{\text{vi}}(\sigma) = e_{\text{ph}}^{\text{vi}}(\sigma)$ holds. However, for the sake of simplicity, instead of directly calculating them we use

$$\begin{aligned} q_{\text{bit}}^{\text{ac}}(\sigma) &:= \text{Tr}(\sigma) - 2e_{\text{bit}}^{\text{ac}}(\sigma) \\ &= \text{Pr}[\text{No Error} | \sigma] - \text{Pr}[\text{Error} | \sigma] \end{aligned}$$

for the actual protocol, and similarly $q_{\text{bit}}^{\text{vi}}$ and $q_{\text{ph}}^{\text{vi}}$ for the virtual protocol. Here $\text{Pr}[\text{Error} | \sigma]$ denotes the bit error rate induced by a mixed state $\sigma(a, b; a', b')$, whereas $\text{Pr}[\text{No Error} | \sigma]$ corresponds to the probability that Alice's and Bob's outcomes coincide. Note here that the sum of the two probability may not be 1 in general since $\sigma(a, b; a', b')$ can be traceless depending on its arguments.

1. Actual Protocol

First we calculate $q_{\text{bit}}^{\text{ac}}$ for the actual protocol. Recall that in the actual protocol, Bob assigns a random value for the output bit whenever coincident detections occur on both detectors. Thus by noting that $|T_{a,b}\rangle_{AB}$ in z -basis takes the form

$$\begin{aligned} |T_{a,b}\rangle_{AB} &= 2^{-(N+1)/2} \sqrt{\binom{N}{b}} \times \\ &\{ |0_z\rangle_A |S_{N,0}^z\rangle_B + i^{-\alpha(a,b)} |1_z\rangle_A |S_{0,N}^z\rangle_B \\ &+ i^{N-2b} (|0_z\rangle_A |S_{0,N}^z\rangle_B - i^{\alpha(a,b)} |1_z\rangle_A |S_{N,0}^z\rangle_B) \} \\ &+ \text{coincidence count terms,} \end{aligned}$$

we obtain

$$\begin{aligned} q_{\text{bit}}^{\text{ac}}(\sigma(a, b; a', b')) &= 0 \text{ if } a \neq a', \\ q_{\text{bit}}^{\text{ac}}(\sigma(0, b; 1, b')) &= 2^{-(N-2)} \sqrt{\binom{N}{b} \binom{N}{b'}} \quad (11) \\ &= q_{\text{bit}}^{\text{ac}}(\sigma(1, b'; 0, b)). \end{aligned}$$

2. Virtual protocol

Next we compute $q_{\text{bit}}^{\text{vi}}$ and $q_{\text{ph}}^{\text{vi}}$ for the virtual protocol, and compare them with $q_{\text{bit}}^{\text{ac}}$ obtained above. Note that $q_{\text{bit}}^{\text{vi}}$ and $q_{\text{ph}}^{\text{vi}}$ can be rewritten as

$$\begin{aligned} q_{\text{bit}}^{\text{vi}}(\sigma) &= \text{Tr}((Z_A \otimes Z_D)F(\sigma)), \\ q_{\text{ph}}^{\text{vi}}(\sigma) &= \text{Tr}((X_A \otimes X_D)F(\sigma)). \end{aligned}$$

Now if $a = a'$, $\sigma(a, b; a', b')$ takes the form

$$\begin{aligned} \sigma(a, b; a', b') &= P(|a_y\rangle_A) \otimes \mu + P(|(1-a)_y\rangle_A) \otimes \nu \\ &= (1 + (-1)^a Y)_A \otimes \mu + (1 - (-1)^a Y)_A \otimes \nu \end{aligned}$$

for some states μ, ν in \mathcal{H}_D . From this we immediately see

$$\begin{aligned} q_{\text{bit}}^{\text{vi}}(\sigma(a, b; a', b')) &= q_{\text{ph}}^{\text{vi}}(\sigma(a, b; a', b')) \\ &= 0 \text{ if } a \neq a'. \end{aligned}$$

On the other hand, for $a \neq a'$, a simple calculation gives

$$\begin{aligned} &F(\sigma(a, b; a', b')) \\ &= 2^{-(N-1)} \sqrt{\binom{N}{b} \binom{N}{b'}} \times \quad (12) \\ &\left[(|a_y\rangle \langle a'_y|)_A \otimes (|(1-a)_y\rangle \langle (1-a')_y|)_D + \text{H.c.} \right] \\ &= 2^{-N} \sqrt{\binom{N}{b} \binom{N}{b'}} (Z_A \otimes Z_D + X_A \otimes X_D), \end{aligned}$$

which yields

$$\begin{aligned} q_{\text{bit}}^{\text{vi}}(\sigma(a, b; a', b')) &= q_{\text{ph}}^{\text{vi}}(\sigma(a, b; a', b')) \\ &= 2^{-(N-2)} \sqrt{\binom{N}{b} \binom{N}{b'}} \quad (13) \end{aligned}$$

for $a \neq a'$.

Hence from eqs. (11), (12) and (13), we see that

$$q_{\text{bit}}^{\text{vi}}(\sigma) = q_{\text{ph}}^{\text{vi}}(\sigma) = q_{\text{bit}}^{\text{ac}}(\sigma) \quad (14)$$

for any $\sigma(a, b; a', b')$, meaning that the same relation holds for any symmetric state ρ_{sym} , i.e., $q_{\text{ph}}^{\text{vi}}(\rho_{\text{sym}}) = q_{\text{bit}}^{\text{vi}}(\rho_{\text{sym}}) = q_{\text{bit}}^{\text{ac}}(\rho_{\text{sym}})$. This is equivalent to our desired result in Eq. (2).

V. BBM92 PROTOCOL WITH BOTH THE PARTIES USING THRESHOLD DETECTORS

By essentially the same arguments as above, it is now straightforward to prove the security of BBM92 protocol where both Alice and Bob are using threshold detectors.

In the actual BBM92 protocol, entangled states are supplied to Alice and Bob from a third party who is not necessarily trusted. Upon receiving pulses, Alice and Bob modulate and measure them in randomly chosen x - or z -basis, and then output sifted key bits by selecting out events where their choices of basis match. If a coincident-detection event occurs, the receiver assigns a random value to the output bit b (Fig. 2).

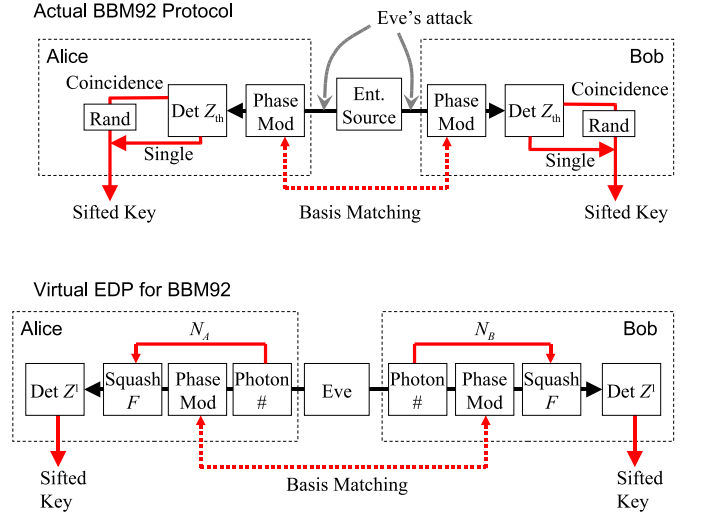

FIG. 2: Schematics of BBM92 protocol and the corresponding virtual EDP. “Ent. Source” denotes a third party that supplies entangled states to Alice and Bob. This third party may be malicious in general.

By repeating the argument of Sec. III, this protocol can be converted into a virtual EDP, as depicted in the lower half of Fig. 2. As before, our question here is whether Alice and Bob can estimate the bit and the phase error rates to be sufficiently small so that secret keys can be extracted. The result is that the relation (2) can be proved in this case as well, and thus the security proofs relying on photon-number discriminating detectors are valid even when threshold detectors are used.

More precisely, the virtual protocol is defined as follows. First, immediately after receiving state ρ_{AB} from Eve, Alice and Bob measure the photon numbers N_A , N_B contained in it, and perform phase modulations to generate a symmetrized density matrix ρ_{sym} . Here in order to take into account the possibility that states Alice receives may contain more than one photon, we generalize $|T_{a,b}\rangle_{AB}$ as

$$|T_{a,b}\rangle_{AB} = |S_{N_A-a,a}^y\rangle_A |S_{N_B-b,b}^y\rangle_B \quad (15)$$

for $0 \leq a \leq N_A$, $0 \leq b \leq N_B$. Note that this reproduces Eq. (4) for $N_A = 1$. Then duplicating the discussion of Sec. IV A, we find that ρ_{sym} is again restricted to be a mixture of $\sigma(a, b; a', b')$ with arguments satisfying condition (10); this time, $\sigma(a, b; a', b')$ and $\alpha(a, b)$ are extended as

$$\begin{aligned} \sigma(a, b; a', b') \\ = |T_{a,b}\rangle\langle T_{a',b'}| + |T_{N_A-a, N_B-b}\rangle\langle T_{N_A-a', N_B-b'}| \end{aligned}$$

and

$$\alpha(a, b) = 2(a + b) - N_A - N_B.$$

The state ρ_{sym} is subsequently projected into an entangled qubit pair by squash operation F performed independently by each party. We denote the qubit state that Alice obtains here as \mathcal{H}_C . As a consequence, Alice and Bob end up sharing an entangled qubit pair in $\mathcal{H}_C \otimes \mathcal{H}_D$.

The rest of the argument is identical to the one given in Sec. IV, hence we omit details. The result is that we again arrive at the relation (14) with explicit forms of $q_{\text{bit}}^{\text{ac}}(\sigma)$ given by

$$q_{\text{bit}}^{\text{ac}}(\sigma) = 2^{-(N_A+N_B-3)} \sqrt{\binom{N_A}{a} \binom{N_A}{a'} \binom{N_B}{b} \binom{N_B}{b'}}$$

for $a - a' \equiv 1 \pmod{2}$, which is equivalent to $b - b' \equiv 1 \pmod{2}$ due to (10). Otherwise $q_{\text{bit}}^{\text{ac}}(\sigma) = 0$.

VI. CONCLUSION

In this paper, we gave a rigorous security proof for BB84, which is valid even when the actual Bob uses threshold detectors. The key ingredients to our proof were the classification of Alice's and Bob's incoming states by symmetry and the introduction of an explicit squash operator F in the virtual protocol. Our results

show that all the formulas for key generation rates obtained in previous proofs based on a virtual qubit entanglement distillation protocol are valid even with threshold detectors. In particular, one can tolerate a higher error rate up to 20% with two-way classical communications [5].

In addition, by using the same technique, we also proved the security of BBM92 protocol, where Alice and Bob both use threshold detectors.

Acknowledgment

This work was supported by the project ‘‘Research and Development on Quantum Cryptography of the National Institute of Information and Communications Technology,’’ as part of Ministry of Internal Affairs and Communications of Japan’s program ‘‘R&D on Quantum Communication Technology.’’

APPENDIX A: PROPERTIES OF SQUASH OPERATORS

In this appendix we show that the squash operator defined in Eq. (1) is a legitimate quantum operation. That is, we demonstrate that for

$$F_{\text{sum}} := \sum_{b,b'} F_{b,b'}^\dagger F_{b,b'},$$

$F_{\text{sum}} = \mathbb{I}_B$ is satisfied. To this end, we work in a basis $\{|S_{N,0}^y\rangle, \dots, |S_{0,N}^y\rangle\}$, and prove $f_{b,b'} = \delta_{b,b'}$ for

$$f_{b,b'} := \langle S_{N-b,b}^y | F_{\text{sum}} | S_{N-b',b'}^y \rangle.$$

First, it is obvious from the definition of F in (1) that $f_{b,b'} = 0$ for $b \neq b'$. On the other hand, if $b = b'$, a simple calculation shows that for a fixed value of b ,

$$f_{b,b} = 2^{-(N-1)} \sum_{b-c \equiv \pm 1} \binom{N}{c},$$

where the sum is over all values of c satisfying $b - c \equiv \pm 1 \pmod{4}$. For b even, this equals

$$f_{b,b} = 2^{-(N-1)} \sum_{c:\text{odd}} \binom{N}{c} = 1,$$

as anticipated. The case of odd b can be shown similarly. This completes the proof.

-
- [1] C. H. Bennett and G. Brassard, in Proceeding of the IEEE International Conference on Computers, Systems, and Signal Processing, Bangalore, India (IEEE, New York, 1984), pp.175-179.
[2] D. Mayers, JACM **48**, 351 (2001).

- [3] H.-K. Lo and H. F. Chau, Science **283**, 2050 (1999).
[4] P. W. Shor and J. Preskill, Phys. Rev. Lett. **85**, 441 (2000).
[5] D. Gottesman and H.-K. Lo, IEEE Trans. Inform. Theory **49**, 457 (2003), H. F. Chau, Phys. Rev. A **66**, 060302(R)

- (2002), K. S. Ranade and G. Alber, *J. Phys. A: Math. Gen.* **39**, 1701 (2006).
- [6] D. Gottesman, H.-K. Lo, N. Lütkenhaus, and J. Preskill, *Quant. Inf. Comput.* **5**, 325 (2004).
- [7] M. Koashi, arXiv:quant-ph/0609180v1.
- [8] B. Kraus, N. Gisin and R. Renner, *Phys. Rev. Lett.* **95**, 080501 (2005); R. Renner, N. Gisin and B. Kraus, *Phys. Rev. A* **72**, 012332 (2005).
- [9] X. -B. Wang, *Phys. Rev. Lett.* **94**, 230503 (2005); H.-K. Lo, X. Ma, and K. Chen, *Phys. Rev. Lett.* **94**, 230504 (2005).
- [10] K. Tamaki, M. Koashi, and N. Imoto, *Phys. Rev. Lett.* **90**, 167904 (2003); K. Tamaki and N. Lütkenhaus, *Phys. Rev. A* **69**, 032316 (2004); K. Tamaki, N. Lütkenhaus, M. Koashi, and J. Batuwantudawe, arXiv:quant-ph/0607082v1.
- [11] C.-H. F. Fung, K. Tamaki, H.-K. Lo, *Phys. Rev. A* **73**, 012337 (2006).
- [12] W. -Y. Hwang, *Phys. Rev. Lett.* **91**, 057901 (2003).
- [13] C. H. Bennett, G. Brassard, and N. D. Mermin, *Phys. Rev. Lett.* **68**, 557 (1992).
- [14] G. Brassard, N. Lütkenhaus, T. Mor, and B. C. Sanders, *Phys. Rev. Lett.* **85**, 1330 (2000); N. Lütkenhaus, *Phys. Rev. A* **61**, 052304 (2000).
- [15] See, e.g., J. J. Sakurai, *Modern Quantum Mechanics, Revised Edition* (Addison-Wesley, Massachusetts, 1994).
- [16] Here we assume that Bob's incoming states are in a single mode.